

Linear Way Module



Linear Way Module

LWLM LWM



LRWM

Points

● Compact module type

Compact linear motion rolling guides consisting of a set of track rail and slide member which forms the smallest unit of linear motion mechanism.

● Models for various usage

Three models are available; LWLM and LWM using the ball for rolling elements, and LRWM using the roller.

● Stainless steel selections for excellent corrosion resistance

LWLM is made of stainless steel of excellent corrosion resistance. They are suitable for applications where rust prevention oil is not preferred, such as in cleanroom environment.

Identification Number and Specification

Example of an identification number

The specification of Linear Way Module series is indicated by the identification number. Indicate the identification number, consisting of a model code, dimensions, a part code, a classification symbol, and any supplemental codes for each specification to apply.

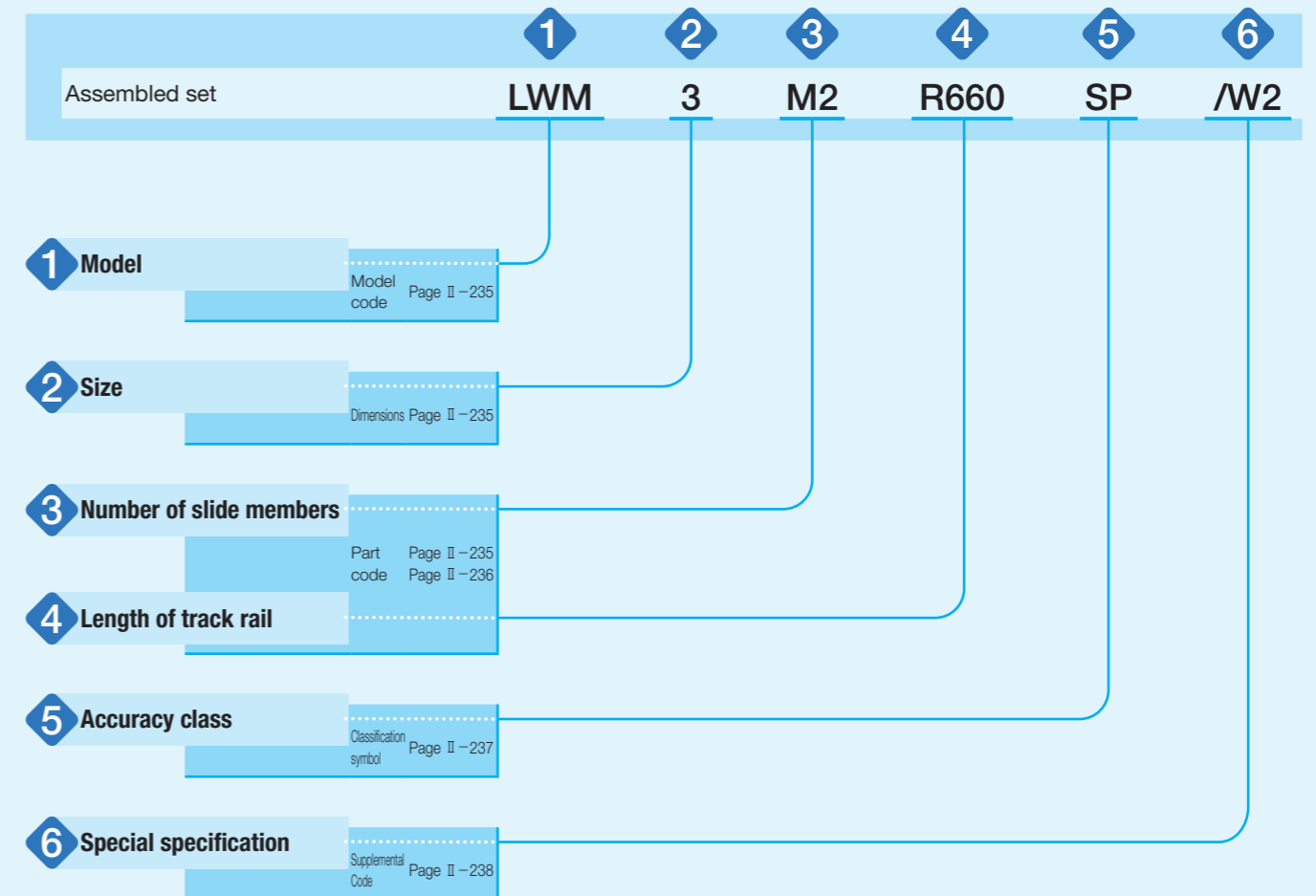

Identification Number and Specification —Model · Size · Number of Slide Member—

1 Model	Linear Way Module	Linear Way LM ⁽¹⁾	: LWLM
		Linear Way M ⁽¹⁾	: LWM
		Linear Roller Way M ⁽¹⁾	: LRWM
For applicable models and sizes, see Table 1.1, 1.2 and 1.3.			
Note ⁽¹⁾ This model has no built-in C-Lube.			
2 Size	7, 9, 11	For applicable models and sizes, see Table 1.1, 1.2 and 1.3.	
	1, 2, 3, 4, 5, 6		
3 Number of slide members		: M○	Indicates the number of slide members assembled on a track rail.

Table 1.1 Model and sizes of LWLM series

Shape	Model	Size		
		7	9	11
	LWLM	○	○	○

Table 1.2 Model and sizes of LWM series

Shape	Model	Size					
		1	2	3	4	5	6
	LWM	○	○	○	○	○	○

Table 1.3 Model and sizes of LRWM series

Shape	Model	Size				
		2	3	4	5	6
	LRWM	○	○	○	○	○

—Length of Track Rail—

4 Length of track rail		: R○	Indicate the length of track rail in mm. For standard and maximum lengths, see Table 2.
-------------------------------	--	------	--

Table 2 Standard and maximum lengths of track rail

unit: mm

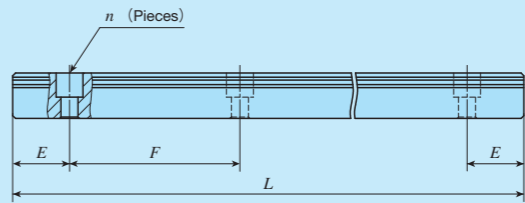

Item	Identification number	LWLM7	LWLM9	LWLM11			
Standard length L (n)		60 (3)	100 (4)	160 (4)			
		80 (4)	150 (6)	240 (6)			
		120 (6)	200 (8)	320 (8)			
		160 (8)	275 (11)	440 (11)			
Pitch of mounting holes F		20	25	40			
E	Standard E dimensions	10	12.5	20			
	or higher below	4.5	5	5.5			
Maximum length ⁽¹⁾		240 (500)	350 (900)	520 (1 000)			
Item	Identification number	LWM1	LWM2	LWM3	LWM4	LWM5	LWM6
Standard length L (n)		240 (6)	240 (4)	480 (8)	800 (10)	800 (8)	1 200 (10)
		360 (9)	360 (6)	660 (11)	1 040 (13)	1 200 (12)	1 920 (16)
		480 (12)	480 (8)	840 (14)	1 200 (15)	1 500 (15)	2 520 (21)
Pitch of mounting holes F		40	60	60	80	100	120
E	Standard E dimensions	20	30	30	40	50	60
	or higher below	7	8	9	10	12	13
Maximum length		27	38	39	50	62	73
Maximum length		1 240	1 260	1 260	1 520	1 500	2 520
Item	Identification number	LRWM2	LRWM3	LRWM4	LRWM5	LRWM6	
Standard length L (n)		480 (8)	480 (8)	800 (10)	800 (8)	1 200 (10)	
		660 (11)	660 (11)	1 040 (13)	1 200 (12)		
		840 (14)	840 (14)	1 200 (15)	1 500 (15)		
Pitch of mounting holes F		60	60	80	100	120	
E	Standard E dimensions	30	30	40	50	60	
	or higher below	8	9	10	12	13	
Maximum length		38	39	50	62	73	
Maximum length		1 800	1 860	1 920	1 600	1 200	

Note ⁽¹⁾ Length up to the value in () can be produced. If needed, please contact **IKO**.
Remark: If not directed, E dimensions for both ends will be the same within the range of standard E dimensions. To change the dimensions, indicate the specified rail mounting hole positions "/ E " of special specification. For more information, see page III-30.

—Accuracy Class—

5 Accuracy class	High	: H	For details of accuracy class, see Table 3.
	Precision	: P	
	Super precision	: SP	

Table 3 Tolerance and allowance

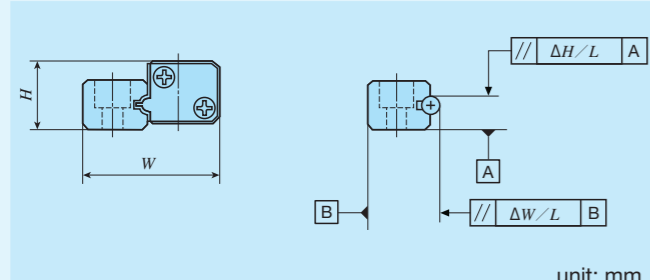

unit: mm			
Class (classification symbol)	High (H)	Precision (P)	Super precision (SP)
Dim. <i>H</i> tolerance	±0.040	±0.020	±0.010
Dim. <i>W</i> tolerance	±0.050	±0.025	±0.015
Dim. variation of <i>H</i> ⁽¹⁾	0.015	0.007	0.005
Dim. variation of <i>W</i> ⁽¹⁾	0.020	0.010	0.007
Track rail parallelism Δ <i>H</i>	See Fig. 1.1 and Fig. 1.2		
Track rail parallelism Δ <i>W</i>	See Fig. 1.1 and Fig. 1.2		

Note (1) It means the size variation between slide members mounted on the same track rail.

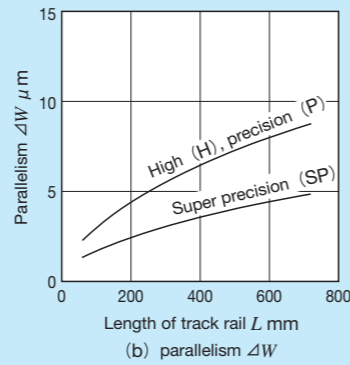
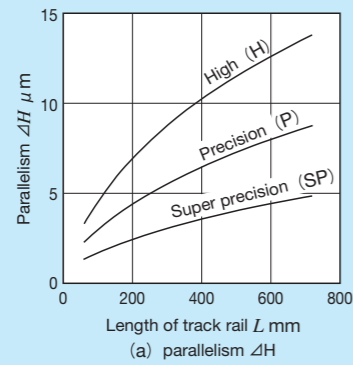

Fig.1.1 Track rail parallelism for LWLM

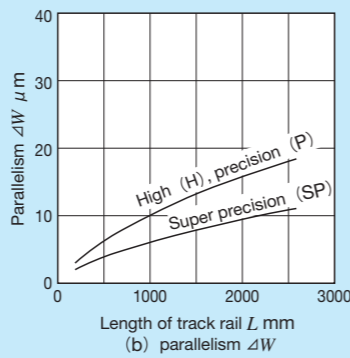
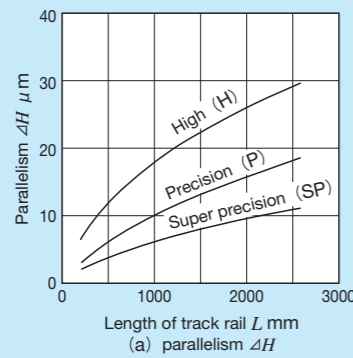

Fig.1.2 Track rail parallelism for LWM and LRWM

—Special Specification—

6 Special specification	/A, /E, /F, /I, /LR, /LFR, /MN, /W, /YO	For applicable special specifications, see Table 4. For combination of multiple special specifications, see Table 5. For details of special specifications, see page III-29.

Table 4 Application of special specifications

Special specification	Supplemental code	Model and size								
		LWLM			LWM, LRWM					
		7	9	11	1	2	3	4	5	6
Butt-jointing track rails	/A	×	×	×	○	○	○	○	○	○
Specified rail mounting hole positions	/E	○	○	○	○	○	○	○	○	○
Caps for rail mounting holes	/F	×	×	×	○	○	○	○	○	○
Inspection sheet	/I	○	○	○	○	○	○	○	○	○
Black chrome surface treatment	/LR	×	×	×	○	○	○	○	○	○
Fluorine black chrome surface treatment	/LFR	×	×	×	○	○	○	○	○	○
Without track rail mounting bolt	/MN	○	○	○	○ ⁽¹⁾	○ ⁽¹⁾	○ ⁽¹⁾	○ ⁽¹⁾	○ ⁽¹⁾	○ ⁽¹⁾
A group of multiple assembled sets	/W	○	○	○	○	○	○	○	○	○
Specified grease	/YO	○	○	○	○	○	○	○	○	○

Note (1) None of mounting bolts for slide member and track rail are appended.

Table 5 Combination of supplemental codes

E	-								
F	○	○							
I	○	○	○						
LR	○	○	○	○					
LFR	○	○	○	○	-				
MN	○	○	○	○	○				
W	○	-	○	○	○	○			
Y	○	○	○	○	○	○	○		
	A	E	F	I	LR	LFR	MN	W	

Remarks 1. The combination of "-" shown in the table is not available.

2. When using multiple types for combination, please indicate by arranging the symbols in alphabetical order.

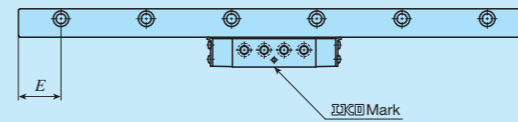

Fig.2 Specified rail mounting hole positions (Supplemental code /E)

Remark: For details of specified rail mounting hole positions (supplemental code /E), see page III-30.

Lubrication

Lithium-soap base grease with extreme-pressure additive (Alvania EP Grease 2 [SHOWA SHELL SEKIYU K. K.]) is pre-packed in Linear Way Module series.

Though grease nipples are not appended to Linear Way Module series, oil holes are provided to slide member so that the grease or lubrication oil supplied from machines / devices is directly guided to the rolling elements recirculation route. Lubrication is easily conducted by providing the supply route in the machines / devices as shown in Fig. 3.

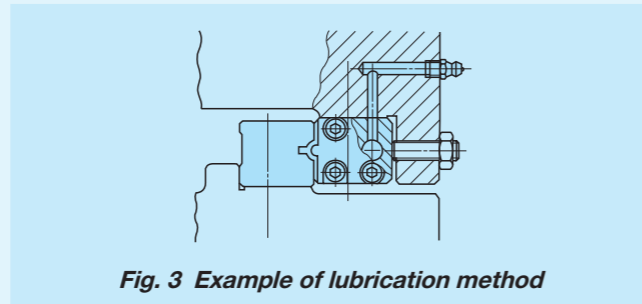

Fig. 3 Example of lubrication method

Dust Protection

The slide members of Linear Way Module series are equipped with end seals as standard for dust protection. However, if large amount of contaminant or dust are floating, or if large

particles of foreign substances such as chips or sand may adhere to the track rail, it is recommended to cover the whole unit with bellows or telescope type shield, etc.

Precaution for Use

1 Mounting surface, reference mounting surface and typical mounting structure

When mounting the Linear Way Module series, properly align the reference mounting surfaces B and D of the track rail and slide member with the reference mounting surface of the table and bed and fix them. (See Fig. 4) The reference mounting surfaces B and D and mounting surfaces A and C are precisely ground. Machining the mounting surface of the table and bed, such as machine or device, to high accuracy and mounting them properly will ensure stable linear motion with high accuracy.

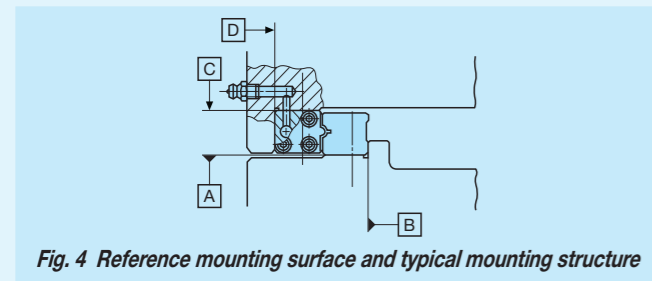

Fig. 4 Reference mounting surface and typical mounting structure

2 Fixing the slide member

Typical mounting structure of Linear Way Module series is shown in Fig. 5. As a convenient means to eliminate play or to give preload in linear motion rolling mechanism, preload adjusting screws are often used.

Set the preload adjusting screws at the positions of fixing bolts of slide member and in the middle of the height of slide member, and then press the slide member by tightening the screw.

For mounting the slide member of Linear Way Module LWLM, it is recommended to fix the slide member from the table side, because the allowance for the preload adjustment in the bolt hole of slide member is small. In this case, the bolt hole and the counterbore in the table should be made larger to give the adjustment allowance.

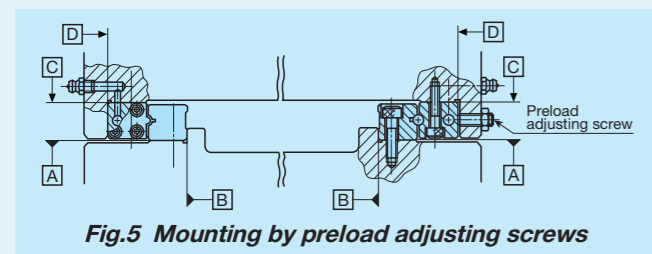

Fig. 5 Mounting by preload adjusting screws

Preload amount varies depending on operational conditions of your machine and device. However, as excessive preload may lead to short life and damage on the raceway, it is typically ideal to adjust to zero clearance or slight preload state.

3 Shoulder height and corner radius of the reference mounting surface

For the opposite corner of the mating reference mounting, it is recommended to have relieved fillet as indicated in Fig. 6. Recommended value for the shoulder height and corner radius on the mating side is indicated in Table 7.1, Table 7.2 and Table 7.3.

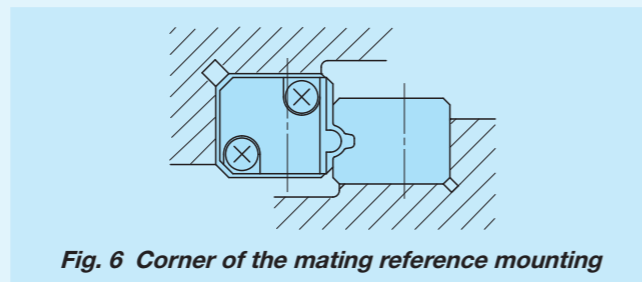

Fig. 6 Corner of the mating reference mounting

4 Tightening torque for fixing screw

Typical tightening torque for mounting of Linear Way Module series to the steel mating member material is indicated in Table 6. When vibration and shock of the machine or device are large, fluctuating load is large, or moment load is applied, fix it by using the torque 1.2 to 1.5 times larger than the value indicated in the table as necessary. If the mating member material is cast iron or aluminum alloy, reduce the tightening torque depending on the strength characteristics of the mating member material.

Table 6 Tightening torque for fixing screw

Bolt size	Tightening torque N · m	
	High carbon steel-made screw	Stainless steel-made screw
M 2.6×0.45	—	0.7
M 3 ×0.5	1.8	1.1
M 4 ×0.7	4.1	—
M 5 ×0.8	8.0	—
M 6 ×1	13.6	—
M 8 ×1.25	32.7	—
M10 ×1.5	63.9	—
M12 ×1.75	110	—

Remark: The tightening torque is calculated based on strength division 12.9 and property division A2-70.

Table 7.1 Shoulder height of the reference mounting surface for LWLM

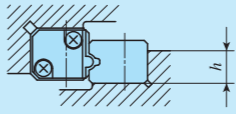

unit: mm

Size	Mounting part of track rail shoulder height h
7	4
9	5
11	6

Table 7.2 Shoulder height and corner radius of the reference mounting surface for LWM

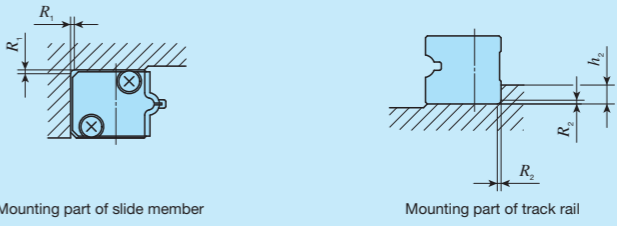

unit: mm

Size	Mounting part of slide member Corner radius R_1 (Maximum)	Mounting part of track rail	
		Shoulder height h_2	Corner radius R_2 (Maximum)
1	0.8	4	0.8
2	1	5	1
3	1	5	1
4	1.5	6	1
5	1.5	6	1
6	1.5	8	1.5

Table 7.3 Shoulder height and corner radius of the reference mounting surface for LRWM



unit: mm

Size	Mounting part of slide member		Mounting part of track rail	
	Shoulder height h_1	Corner radius R_1 (Maximum)	Shoulder height h_2	Corner radius R_2 (Maximum)
2	7	1	5	1
3	8.5	1	6	1
4	10.5	1.5	6	1
5	12.5	1.5	8	1
6	14.5	2	8	1.5

IKO Linear Way Module

Linear Way LM			
Shape	LWLM		
Size	7	9	11

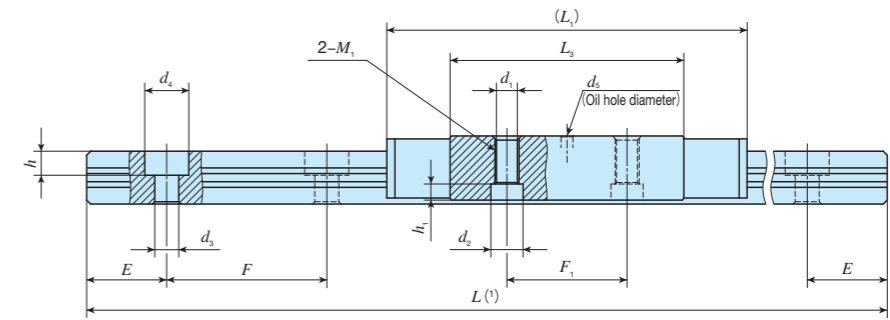
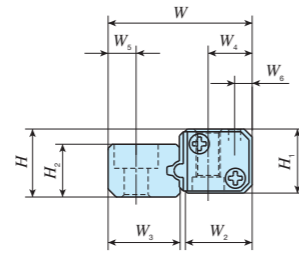

Identification number	Mass (Ref.)		Dimensions of assembly mm		Dimensions of slide member mm										Dimensions of track rail mm						Appended mounting bolt for track rail ⁽²⁾	Basic dynamic load rating ⁽³⁾	Basic static load rating ⁽³⁾				
	Linear Way Module series (No C-Lube)	Slide member g	Track rail g/m	H	W	H ₁	W ₂	W ₄	W ₆	L ₁	L ₃	F ₁	d ₁	d ₂	h ₁	M ₁	d ₅	H ₂	W ₃	W ₅				d ₃	d ₄	h	E
LWLM 7*	10	210	7	15	6.6	7.8	5	2.5	38	24	12	—	—	—	M2.6	1	4.8	6.8	3.3	3 ⁽⁴⁾	— ⁽⁴⁾	— ⁽⁴⁾	10	20	M2.6 × 8 ⁽⁴⁾	1 730	2 020
LWLM 9*	16	390	8.5	18	8	8.6	5.5	2.2	45	29.2	15	—	—	—	M3	1.5	6.6	9	3.5	3	5.5	3	12.5	25	M2.6 × 8	2 780	3 150
LWLM 11*	32	590	11	23	10	11.8	7	3	52	32.8	15	2.55	5	3	M3	2	8	10.8	5	3.5	6	4.5	20	40	M3 × 8	4 080	4 240

Notes ⁽¹⁾ Track rail lengths L are shown in Table 2 on page II-236.

⁽²⁾ The appended mounting bolts are stainless steel hexagon socket head bolts equivalent to JIS B 1176.

⁽³⁾ The direction of basic dynamic load rating (C) and basic static load rating (C_0) are shown in the sketch below.

⁽⁴⁾ Track rail mounting holes have no counterbore.

When the appended track rail mounting bolts are used, the height from track rail bottom surface to bolt head is 7.4 mm.

Remarks 1. Slide member mounting bolts are not appended.

2. The identification numbers with * are our semi-standard items.

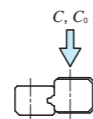

Example of identification number of assembled set

Model code	Dimensions	Part code	Classification symbol	Supplemental code
LWLM	9	M2 R200	P	/W2
①	②	③	④	⑤
① Model LWLM Linear Way LM	② Size 7, 9, 11	③ Number of slide member (2)	④ Length of track rail (200 mm)	⑤ Accuracy class H High P Precision SP Super precision
				⑥ Special specification E, I, MN, W, Y

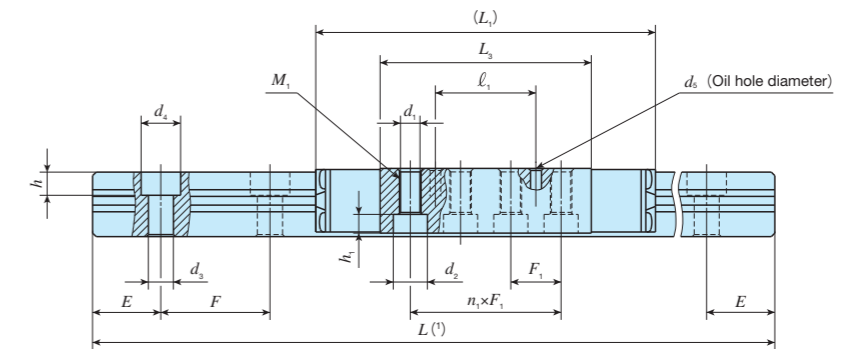
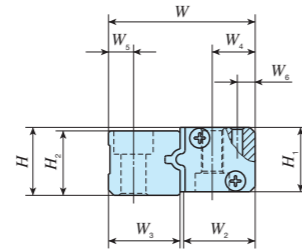
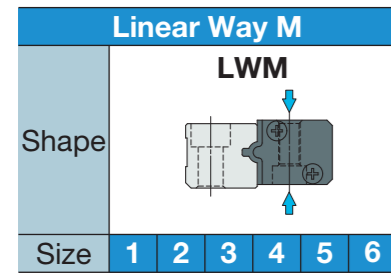

Identification number	Mass (Ref.)		Dimensions of assembly mm		Dimensions of slide member mm										Appended mounting bolt for slide member ⁽²⁾	Dimensions of track rail mm							Appended mounting bolt for track rail ⁽²⁾	Basic dynamic load rating ⁽³⁾ C N	Basic static load rating ⁽³⁾ C ₀ N				
	Slide member kg	Track rail kg/m	H	W	H ₁	W ₂	W ₄	W ₆	L ₁	L ₃	n ₁ × F ₁	d ₁	d ₂	h ₁		M ₁	ℓ ₁	d ₅	Bolt size × ℓ	H ₂	W ₃	W ₅				d ₃	d ₄	h	E
LWM 1*	0.07	1.20	14	28	13	14.6	9	4	64	41.2	2 × 13	3.4	6.5	3.1	M 4	13	2	M3 × 14	13	13	5.5	4.5	8	4.5	20	40	M 4 × 14	4 720	6 410
LWM 2*	0.11	1.93	17	35	16	17	10	4	75	47.2	2 × 15	4.4	8	4.1	M 5	15	3	M4 × 18	16	17	6	6	9.5	5.4	30	60	M 5 × 18	7 150	9 240
LWM 3*	0.17	2.71	19	41	18	20	12	5	95	58.8	3 × 14	5.4	9.5	5.2	M 6	—	3	M5 × 20	18	20	7	7	11	6.5	30	60	M 6 × 20	13 700	16 600
LWM 4*	0.32	3.49	21	51	20	25	15	6	122	80.6	3 × 20	6.8	11	6.2	M 8	—	3	M6 × 22	20	25	9	9	14	9	40	80	M 8 × 22	23 200	27 400
LWM 5*	0.56	5.25	25	63	24	30	18	8	145	94.8	4 × 20	6.8	11	6.2	M 8	20	3	M6 × 28	24	31	12	11	17.5	11	50	100	M10 × 25	35 300	41 000
LWM 6*	1.35	7.56	31	78	30	40	24	11	180	131	5 × 22	8.6	14	8.2	M10	—	3	M8 × 35	30	36	14	14	20	13	60	120	M12 × 35	74 100	80 900

Notes ⁽¹⁾ Track rail lengths L are shown in Table 2 on page II - 236.

⁽²⁾ The appended mounting bolts are hexagon socket head bolts equivalent to JIS B 1176.

⁽³⁾ The direction of basic dynamic load rating (C) and basic static load rating (C_0) are shown in the sketch below.

Remark: The identification numbers with * are our semi-standard items.

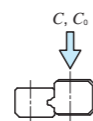

Example of identification number of assembled set

Model code Dimensions Part code Classification symbol Supplemental code

LWM **3** **M2 R660** **P** **/W2**

① ② ③ ④ ⑤ ⑥

① Model
LWM Linear Way M

② Size
1, 2, 3, 4, 5, 6

③ Number of slide member (2)

④ Length of track rail (660 mm)

⑤ Accuracy class
H High
P Precision
SP Super precision

⑥ Special specification
A, E, F, I, LR, LFR
MN, W, Y

Linear Roller Way M						
Shape	LRWM					
Size	2	3	4	5	6	

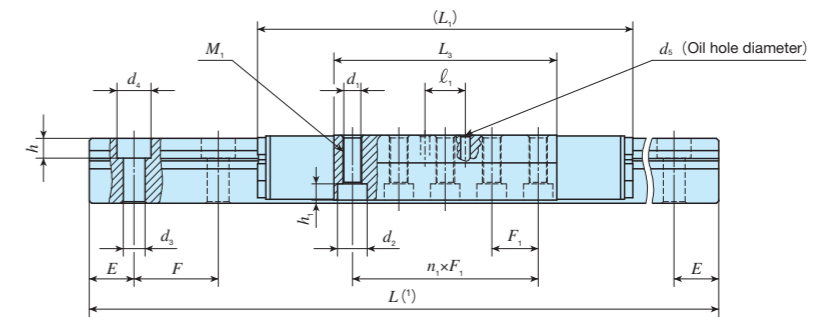
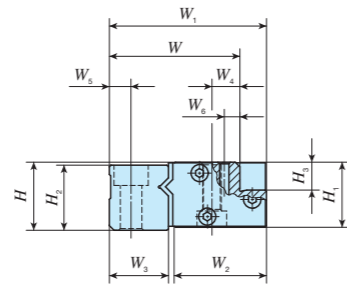

Identification number	Mass (Ref.)		Dimensions of assembly mm			Dimensions of slide member mm															Appended mounting bolt for slide member ⁽²⁾	Dimensions of track rail mm										Appended mounting bolt for track rail ⁽²⁾	Basic dynamic load rating ⁽³⁾ C N	Basic static load rating ⁽³⁾ C ₀ N
	Slide member kg	Track rail kg/m	H	W	W ₁	H ₁	H ₃	W ₂	W ₄	L ₁	L ₃	n×F ₁	M ₁	d ₁	d ₂	h ₁	W ₆	ℓ ₁	d ₅	Bolt size × ℓ		H ₂	W ₃	W ₅	d ₃	d ₄	h	E	F	Bolt size × ℓ				
LRWM 2*	0.26	1.98	19	33	39.6	18	7.5	22.9	8	105	63	4×12	M 5	4.4	8	4.1	4	10	3	M4×20	18	15	6	6	9.5	5.4	30	60	M 5×20	9 700	10 800			
LRWM 3*	0.46	2.92	22	42	50.6	21	9	29.8	9	122	72	4×15	M 6	5.4	9.5	5.2	5	13	3	M5×25	21	19	7	7	11	6.5	30	60	M 6×25	18 500	20 300			
LRWM 4*	0.98	4.64	28	56	65.6	27	11	39.4	13	157	96	5×16	M 8	6.8	11	6.2	6	—	3	M6×32	27	24	9	9	14	8.6	40	80	M 8×32	36 500	39 800			
LRWM 5*	2.03	6.85	33	70	81.6	32	13	49.1	16	212	140	5×24	M10	8.6	14	8.2	7	—	3	M8×35	32	30	12	11	17.5	10.8	50	100	M10×35	67 900	75 500			
LRWM 6*	3.42	9.25	38	83	96.6	37	15	58.6	21	256	168	6×25	M10	8.6	14	8.2	8	28	3	M8×40	37	35	14	14	20	13	60	120	M12×40	99 800	109 000			

Notes ⁽¹⁾ Track rail lengths *L* are shown in Table 2 on page II-236.
⁽²⁾ The appended mounting bolts are hexagon socket head bolts equivalent to JIS B 1176.
⁽³⁾ The direction of basic dynamic load rating (*C*) and basic static load rating (*C₀*) are shown in the sketch below.
 Remark: The identification numbers with * are our semi-standard items.

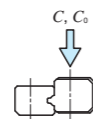

Example of identification number of assembled set

Model code	Dimensions	Part code	Classification symbol	Supplemental code
LRWM	3	M2 R660	P	/W2
①	②	③	④	⑤

① Model
LRWM Linear Roller Way M

② Size
2, 3, 4, 5, 6

③ Number of slide member (2)

④ Length of track rail (660 mm)

⑤ Accuracy class

H	High
P	Precision
SP	Super precision

⑥ Special specification

A, E, F, I, LR, LFR
MN, W, Y