

# SPHERICAL BUSHINGS

- Steel-on-steel Spherical Bushings
- Maintenance-free Spherical Bushings



## Structure and Features

**IKO** Spherical Bushings are self-aligning spherical plain bushings that have inner and outer rings with spherical sliding surfaces, and can take a large radial load and a bi-directional axial load at the same time. There are many types of Spherical Bushings, but they are basically divided into steel-on-steel types and maintenance-free types according to the kind of sliding surfaces.

Steel-on-steel Spherical Bushings have inner and outer rings of high carbon chromium bearing steel, of which sliding surfaces are phosphate-treated and then dry-coated with molybdenum disulfide (MoS<sub>2</sub>). They can, therefore, operate with low torque, and have excellent wear resistance and large load capacity. They are especially suitable for applications where there are alternate loads and shock loads. They have wide applications mainly in industrial and construction machinery.

Maintenance-free Spherical Bushings consist of an outer ring which has a special PTFE liner reinforced with copper alloy meshes on the sliding surface, and a spherical inner ring of which sliding surface has a hard chromium plating. Creep deformation due to compressive load is small, and wear resistance is superior. Thus, they are maintenance-free and can be used for extended periods of time without re-lubrication. They are especially suitable in cases where fixed directional loads are applied and are used mainly in food processing machines and construction machinery and in other applications in which the use of oil is undesirable or lubrication is not possible.

## Types

Spherical Bushings are available in various types shown in Table 1.

**Table 1 Type of bearing**

| Series | Type         | Steel-on-steel |            | Maintenance-free |               |
|--------|--------------|----------------|------------|------------------|---------------|
|        |              | Without seals  | With seals | Without seals    | With seals    |
| Metric | SB           |                | —          | GE ... EC        | GE ... EC-2RS |
|        | SB ... A     |                | —          |                  |               |
|        | GE ... E, ES | GE ... ES-2RS  |            |                  |               |
|        | GE ... G, GS | GE ... GS-2RS  |            |                  |               |
| Inch   | SBB          | SBB ... -2RS   | —          | —                |               |

### Structures of Spherical Bushings

#### Steel-on-steel type

SB ... A

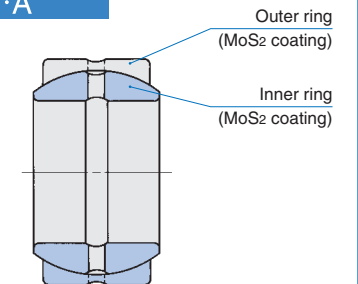

#### Steel-on-steel type

GE ... ES-2RS

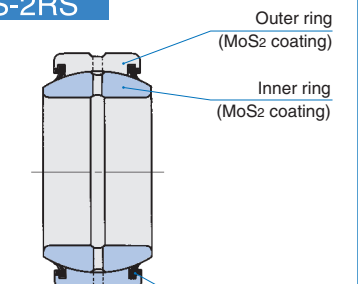

#### Maintenance-free type

GE ... EC

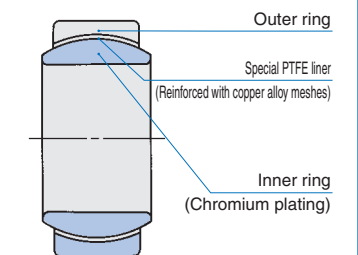

#### Maintenance-free type

GE ... EC-2RS

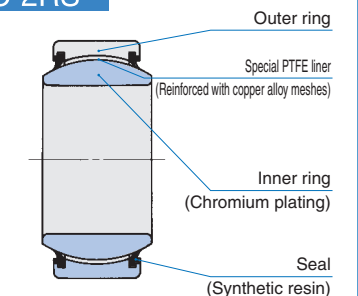

K

SB  
GE  
SBB

**Steel-on-steel Spherical Bushings SB**

These bushings have an outer ring split into halves. The split outer ring and the inner ring are held together by a snap ring placed in the groove around the outer periphery of the outer ring.

**Steel-on-steel Spherical Bushings SB...A**

These bushings have an outer ring split only at one position, and therefore, the outer and inner rings will not separate. Handling before mounting and mounting to the housing are simple. The boundary dimensions are the same as those of the SB type. Therefore, SB and SB...A types are dimensionally interchangeable, but the radial internal clearances of the SB...A type are smaller than those of the SB type.

**Steel-on-steel Spherical Bushings GE...E, GE...ES**

The dimension series of these types conform to ISO standards and they can be used internationally. The outer ring is split at one position. The GE...E and GE...ES types are available. These are classified by bushing size.

The GE...ES type can be provided with seals, which are double-lip type polyurethane seals effective for prevention against grease leakage and dust penetration. The sealed type is indicated by the suffix "-2RS" at the end of the identification number.

**Steel-on-steel Spherical Bushings GE...G, GE...GS**

As compared with the GE...E and GE...ES types, these bushings have larger load capacities and larger permissible tilting angles. The dimension series also conform to ISO standards, and they can be used internationally. The outer ring is split at one position. The GE...G and GE...GS types are available. They are classified by bushing size.

The GE...GS type can be provided with seals, which are double-lip type polyurethane seals effective for prevention against grease leakage and dust penetration.

**Steel-on-steel Spherical Bushings SBB**

These are inch series bushings. The outer ring is split at one position.

These bushings can be provided with seals, which are double-lip type polyurethane seals effective for prevention against grease leakage and dust penetration.

**Maintenance-free Spherical Bushings GE...EC**

These bushings have the same boundary dimensions as the GE...ES type and can be used internationally. A special PTFE liner reinforced with copper alloy meshes is used on the sliding surface. Therefore, creep deformation due to compressive loads is small, and wear resistance is superior. These bushings are used as maintenance-free bushings.

These bushings can be provided with synthetic resin seals which are effective in preventing dust penetration. They are indicated by the suffix "-2RS" at the end of the identification number.

Spherical Bushings with superior rust prevention properties, which can be used in a corrosive environment or in an environment where water splashes, are also available on request. Please consult **IKO**.

**Identification number**

The identification number of Spherical Bushings consists of a model code, a size and any supplemental codes. Examples are shown below.

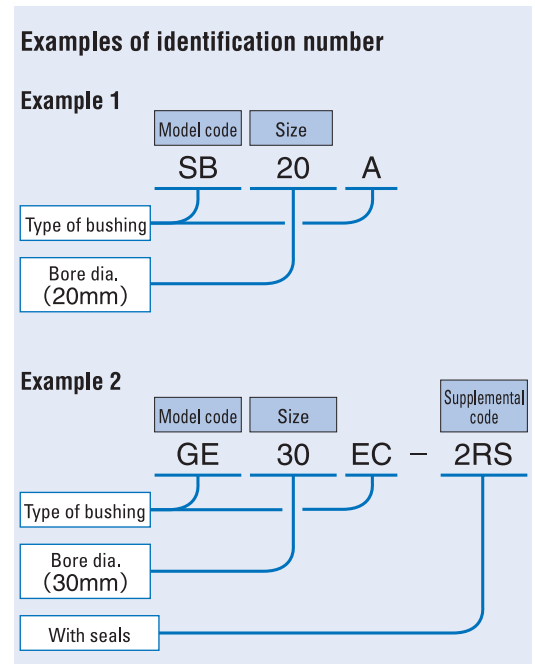

**Accuracy**

The tolerances of Steel-on-steel Spherical Bushings of the metric series is shown in Table 2.

The tolerances of the GE type are applicable to bushings before splitting the outer ring and after surface treatment.

The tolerances of the SB and SB...A types are applicable to bushings before splitting the outer ring and before surface treatment.

The tolerances of the GE...EC type are applicable to bushings before splitting the outer ring.

The tolerances of the Spherical Bushings of the inch series are shown in Table 3. The tolerances of the bore diameter are applicable to bushings after surface treatment, while other tolerances are applicable to bushings before splitting the outer ring and before surface treatment.

Although minor dimensional changes may occur during surface treatment, they have negligible influence on the overall performance.

Table 2 Tolerances of inner and outer rings of metric series (JIS Class 0) unit:  $\mu$ m

| $d$ or $D$ <sup>(1)</sup><br>Nominal bore dia. or<br>outside dia.<br>mm | $\Delta_{dmp}$<br>Single plane<br>mean bore dia.<br>deviation |        | $\Delta_{Dmp}$<br>Single plane<br>mean outside<br>dia. deviation |      | $\Delta_{Bs}$ or $\Delta_{Cs}$<br>Deviation of a single<br>inner ring width or<br>outer ring width |      |
|---|---|--------|--|------|--|------|
|   | High  | Low    | High   | Low  | High   | Low  |
| 2.5   | 6   | 0 - 8  | -  | -    | 0  | -120 |
| 6   | 18  | 0 - 8  | 0  | - 8  | 0  | -120 |
| 18  | 30  | 0 - 10 | 0  | - 9  | 0  | -120 |
| 30  | 50  | 0 - 12 | 0  | - 11 | 0  | -120 |
| 50  | 80  | 0 - 15 | 0  | - 13 | 0  | -150 |
| 80  | 120   | 0 - 20 | 0  | - 15 | 0  | -200 |
| 120   | 150   | 0 - 25 | 0  | - 18 | 0  | -250 |
| 150   | 180   | 0 - 25 | 0  | - 25 | 0  | -250 |
| 180   | 250   | 0 - 30 | 0  | - 30 | 0  | -300 |
| 250   | 315   | 0 - 35 | 0  | - 35 | 0  | -350 |
| 315   | 400   | 0 - 40 | 0  | - 40 | 0  | -400 |
| 400   | 500   | 0 - 45 | 0  | - 45 | 0  | -450 |

Note<sup>(1)</sup>  $d$  for  $\Delta_{dmp}$ ,  $\Delta_{Bs}$  and  $\Delta_{Cs}$  and  $D$  for  $\Delta_{Dmp}$ , respectively.

Table 3 Tolerances of inner and outer rings of inch series SBB unit:  $\mu$ m

| $d$ or $D$ <sup>(1)</sup><br>Nominal bore dia. or<br>outside dia.<br>mm | $\Delta_{dmp}$<br>Single plane<br>mean bore dia.<br>deviation |        | $\Delta_{Dmp}$<br>Single plane<br>mean outside<br>dia. deviation |        | $\Delta_{Bs}$ or $\Delta_{Cs}$<br>Deviation of a single<br>inner ring width or<br>outer ring width |       |
|---|---|--------|--|--------|--|-------|
|   | High  | Low    | High   | Low    | High   | Low   |
| -   | 50.800  | 0 - 13 | 0  | - 13   | 0  | - 130 |
| 50.800  | 76.200  | 0 - 15 | 0  | - 15   | 0  | - 130 |
| 76.200  | 80.962  | 0 - 20 | 0  | - 15   | 0  | - 130 |
| 80.962  | 120.650   | 0 - 20 | 0  | - 20   | 0  | - 130 |
| 120.650   | 152.400   | 0 - 25 | 0  | - 25   | 0  | - 130 |
| 152.400   | 177.800   | -      | -  | 0 - 25 | 0  | - 130 |
| 177.800   | 222.250   | -      | -  | 0 - 30 | 0  | - 130 |

Note<sup>(1)</sup>  $d$  for  $\Delta_{dmp}$ ,  $\Delta_{Bs}$  and  $\Delta_{Cs}$  and  $D$  for  $\Delta_{Dmp}$ , respectively.

**Clearance**

The radial internal clearances of Spherical Bushings are the values before splitting the outer ring, and are shown in Tables 4, 5 and 6. The radial internal clearances of the inch series are shown in the dimension table.

Clearances other than these can also be prepared on request. Please consult **IKO**.

Table 4 Radial internal clearance of SB and SB...A types (Steel-on-steel) unit:  $\mu$ m

| Nominal bore dia.<br>$d$<br>mm | SB type |      | SB...A type |      |
|--------------------------------|---------|------|-------------|------|
|                                | Min.    | Max. | Min.        | Max. |
| 12                             |         |      | 32          | 68   |
| 15                             | 70      | 125  | 40          | 82   |
| 20                             |         |      |             |      |
| 22                             |         |      | 50          | 100  |
| 25                             | 75      | 140  |             |      |
| 30                             |         |      |             |      |
| 35                             |         |      | 60          | 120  |
| 40                             | 85      | 150  |             |      |
| 45                             |         |      |             |      |
| 50                             |         |      | 72          | 142  |
| 55                             |         |      |             |      |
| 60                             | 90      | 160  |             |      |
| 65                             |         |      |             |      |
| 70                             |         |      | 72          | 142  |
| 75                             | 95      | 170  |             |      |
| 80                             |         |      |             |      |
| 85                             |         |      | 85          | 165  |
| 90                             | 100     | 185  |             |      |
| 95                             |         |      |             |      |
| 100                            |         |      | 85          | 165  |
| 110                            |         |      |             |      |
| 115                            | 110     | 200  |             |      |
| 120                            |         |      |             |      |
| 130                            |         |      | 100         | 192  |
| 150                            | 120     | 215  |             |      |

**Table 5 Radial internal clearance of GE type (Steel-on-steel)**  
unit:  $\mu$  m

| Nominal bore dia. mm |                   | Radial internal clearance |      |
|----------------------|-------------------|---------------------------|------|
| GE...E<br>GE...ES    | GE...G<br>GE...GS | Min.                      | Max. |
| 4                    | —                 | 32                        | 68   |
| 5                    | —                 |                           |      |
| 6                    | —                 |                           |      |
| 8                    | 6                 |                           |      |
| 10                   | 8                 |                           |      |
| 12                   | 10                | 40                        | 82   |
| 15                   | 12                |                           |      |
| 17                   | 15                |                           |      |
| 20                   | 17                |                           |      |
| 25                   | 20                |                           |      |
| 30                   | 25                | 50                        | 100  |
| 35                   | 30                |                           |      |
| 40                   | 35                |                           |      |
| 45                   | 40                |                           |      |
| 50                   | 45                |                           |      |
| 60                   | 50                | 60                        | 120  |
| 70                   | 60                |                           |      |
| 80                   | 70                |                           |      |
| 90                   | 80                |                           |      |
| 100                  | 90                |                           |      |
| 110                  | 100               | 85                        | 165  |
| 120                  | 110               |                           |      |
| 140                  | 120               |                           |      |
| 160                  | 140               |                           |      |
| 180                  | 160               |                           |      |
| 200                  | 180               | 100                       | 192  |
| 220                  | 200               |                           |      |
| 240                  | 220               |                           |      |
| 260                  | 240               |                           |      |
| 280                  | 260               |                           |      |
| 300                  | 280               | 110                       | 214  |

Remark Also applicable to bushings with seals.

**Table 6 Radial internal clearance of GE...EC type (Maintenance-free)**  
unit:  $\mu$  m

| Nominal bore dia. mm | Radial internal clearance |      |
|----------------------|---------------------------|------|
|                      | Min.                      | Max. |
| 15                   | 0                         | 40   |
| 17                   |                           |      |
| 20                   |                           |      |
| 25                   | 0                         | 50   |
| 30                   |                           |      |
| 35                   |                           |      |
| 40                   |                           |      |
| 45                   | 0                         | 60   |
| 50                   |                           |      |
| 60                   |                           |      |
| 70                   |                           |      |
| 70                   | 0                         | 72   |

Remark Also applicable to bushings with seals.

**Fit**

The recommended fits for Spherical Bushings are shown in Tables 7 and 8.

**Table 7 Recommended fits for Steel-on-steel Spherical Bushings**

| Condition                             | Tolerance class |              |
|---------------------------------------|-----------------|--------------|
|                                       | Shaft           | Housing bore |
| Normal operation                      | h6, j6          | H7, J7       |
| With directionally indeterminate load | m6, n6          | M7, N7       |

Remark N7 tolerance is recommended for light metal housings.

**Table 8 Recommended fits for Maintenance-free Spherical Bushings**

| Tolerance class of shaft | Tolerance class of housing bore |
|--------------------------|---------------------------------|
| h6, j6                   | H7, J7, K7                      |

Remark K7 tolerance is recommended for light metal housings.

**Selection of Spherical Bushings**

Selection between the steel-on-steel type and the maintenance-free type is made considering the operating conditions such as load, lubrication, temperature, and sliding velocity.

**Load capacity**

**1 Dynamic load capacity**

The dynamic load capacity  $C_d$  is the maximum allowable load that can be applied on a spherical bushing under oscillating motion. It is obtained on the basis of the contact pressure on the spherical surfaces. The dynamic load capacity is also used for calculating the life of spherical bushings.

The recommended value of bushing load is obtained by multiplying the dynamic load capacity  $C_d$  by a numerical factor, which differs depending on the bushing type and the load condition. A guideline for selection is shown in Table 9.

**Table 9 Guide for determination of load**

| Type of bushing  | Load direction |               |
|------------------|----------------|---------------|
|                  | Constant       | Alternate     |
| Steel-on-steel   | $\leq 0.3C_d$  | $\leq 0.6C_d$ |
| Maintenance-free | $\leq C_d$     | $\leq 0.5C_d$ |

When the magnitude of load exceeds the value given in Table 9, please consult **IKO**.

The dynamic load capacity  $C_{dt}$  considering the influence of bushing temperature can be obtained from the following equation using the temperature factor.

$$C_{dt} = f_t C_d \quad \text{.....(1)}$$

where,  $C_{dt}$  : Dynamic load capacity considering temperature increase N

$f_t$  : Temperature factor (Refer to Table 10.)

$C_d$  : Dynamic load capacity N (Refer to the dimension tables.)

**Table 10 Temperature factor  $f_t$**

| Type of bushing  |               | Temperature $^{\circ}$ C |            |             |              |              |              |
|------------------|---------------|--------------------------|------------|-------------|--------------|--------------|--------------|
|                  |               | -30<br>+80               | +80<br>+90 | +90<br>+100 | +100<br>+120 | +120<br>+150 | +150<br>+180 |
| Steel-on-steel   | Without seals | 1                        | 1          | 1           | 1            | 1            | 0.7          |
|                  | With seals    | 1                        | —          | —           | —            | —            | —            |
| Maintenance-free | Without seals | 1                        | 1          | 0.9         | 0.75         | 0.55         | —            |
|                  | With seals    | 1                        | —          | —           | —            | —            | —            |

**2 Static load capacity**

The static load capacity  $C_s$  is the maximum static load that can be applied on the spherical bushing without breaking inner and outer rings or causing any permanent deformation severe enough to render the bushing unusable.

It must be noted that if the magnitude of the applied load becomes comparable to the static load capacity of bushing, the stresses in the shaft or housing may also reach to their limits. This possibility must be taken into consideration in the design.

**Equivalent radial load**

Spherical Bushings can take radial and axial loads at the same time. When the magnitude and direction of loads are constant, the equivalent radial load can be obtained from the following formula.

$$P = F_r + YF_a \quad \text{.....(2)}$$

where,  $P$  : Equivalent radial load N

$F_r$  : Radial load N

$F_a$  : Axial load N

$Y$  : Axial load factor (Refer to Table 11.)

**Table 11 Axial load factor  $Y$**

| Type of bushing  | $F_a/F_r$ |     |     |          |     |          |
|------------------|-----------|-----|-----|----------|-----|----------|
|                  | 0.1       | 0.2 | 0.3 | 0.4      | 0.5 | > 0.5    |
| Steel-on-steel   | 1         | 2   | 3   | 4        | 5   | Unusable |
| Maintenance-free | 1         | 2   | 3   | Unusable |     |          |

**Life**

The life of Spherical Bushings is defined as the total number of oscillating motions before the bushings cannot be operated normally because of wear, increase in internal clearance, increase in sliding torque, rise of operating temperature, etc.

As the actual life is affected by many factors such as the material of the sliding surface, the magnitude and direction of load, lubrication, sliding velocity, etc., the calculated life can be used as a practical measure of expected service life.

**1 Life of Steel-on-steel spherical bushings**

[1] Confirmation of  $pV$  value

Before attempting to calculate the life, make sure that the operating conditions are within the permissible range by referring to the  $pV$  diagram in Fig.1.

When the operating conditions are out of the permissible range, please consult **IKO**.

The contact pressure  $p$  and the sliding velocity  $V$  are obtained from the following formulae.

$$p = \frac{100P}{C_{dt}} \quad \text{.....(3)}$$

$$V = 5.82 \times 10^{-4} d_k \beta f \quad \text{.....(4)}$$

where,  $p$  : Contact pressure N/mm<sup>2</sup>

$P$  : Equivalent radial load N (Refer to Formula (2).)

$C_{dt}$  : Dynamic load capacity considering temperature increase N (Refer to Formula (1).)

$V$  : Sliding velocity mm/s

$d_k$  : Sphere diameter mm

(Refer to the dimension tables.)

$2\beta$  : Oscillating angle degrees (Refer to Fig.2.)

when  $\beta < 5^{\circ}$ ,  $\beta = 5$

when rotating,  $\beta = 90$

$f$  : Number of oscillations per minute cpm

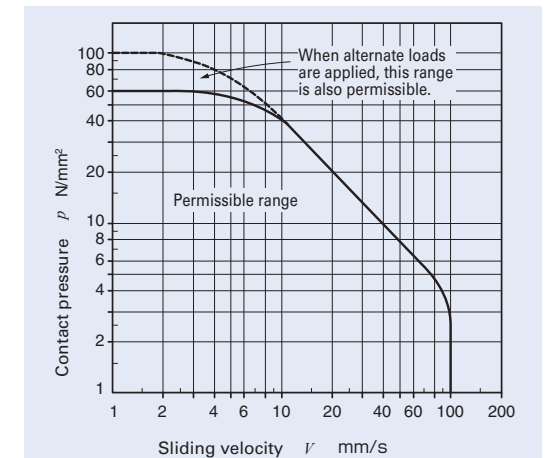

**Fig.1  $pV$  diagram of Steel-on-steel spherical bushings**

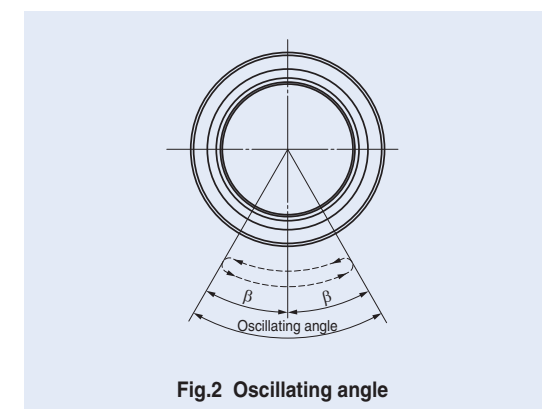

**Fig.2 Oscillating angle**

[2] Life calculation

The life of steel-on-steel spherical bushings can be calculated from the following formulae.

$$G = \frac{3.18b_1b_2b_3}{\sqrt{d_k} \beta} \left(\frac{C_{dt}}{P}\right)^2 \times 10^5 \dots\dots\dots (5)$$

$$L_h = \frac{G}{60f} \dots\dots\dots (6)$$

- where,  $G$  : Life (Total number of oscillations)
- $b_1$  : Load directional factor (Refer to Table 12.)
- $b_2$  : Lubrication factor (Refer to Table 13.)
- $b_3$  : Sliding velocity factor (Refer to Fig.3.)
- $C_{dt}$  : Dynamic load capacity considering temperature increase N  
(Refer to Formula (1).)
- $P$  : Equivalent radial load N  
(Refer to Formula (2).)
- $L_h$  : Life in hours h
- $f$  : Number of oscillations per minute cpm

**Table 12 Load directional factor  $b_1$  (Steel-on-steel)**

| Load direction                | Constant | Alternate |
|-------------------------------|----------|-----------|
| Load directional factor $b_1$ | 1        | 5         |

**Table 13 Lubrication factor  $b_2$**

| Periodical lubrication   | None | Regular |
|--------------------------|------|---------|
| Lubrication factor $b_2$ | 1    | 15      |

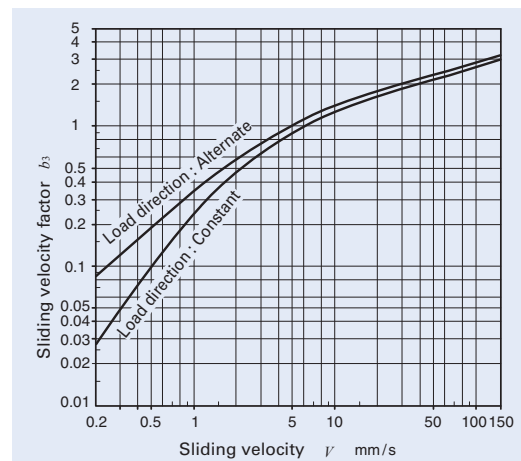

**Fig.3 Sliding velocity factor**

**② Life of Maintenance-free spherical bushings**

[1] Confirmation of  $pV$  value

Before attempting to calculate the life, make sure that the operating conditions are within the permissible range by referring to the  $pV$  diagram in Fig.4.

When the operating conditions are out of the permissible range, please consult **IKO**.

The contact pressure  $p$  and the sliding velocity  $V$  are obtained from Formulae (3) and (4) shown on page J10.

[2] Life calculation

The life of maintenance-free spherical bushings is obtained from the total sliding distance  $S$  which is given in Fig.5 for the contact pressure  $p$  obtained from Formula (3).

The total number of oscillations and life in hours can be obtained from the following formulae.

$$G = 16.67 \times b_1 \frac{Sf}{V} \dots\dots\dots (7)$$

$$L_h = \frac{G}{60f} \dots\dots\dots (8)$$

- where,  $G$  : Life (Total number of oscillations)
- $b_1$  : Load directional factor (Refer to Table 14.)
- $S$  : Total sliding distance m (Refer to Fig.5.)
- $f$  : Number of oscillations per minute cpm
- $V$  : Sliding velocity mm/s
- $L_h$  : Life in hours h

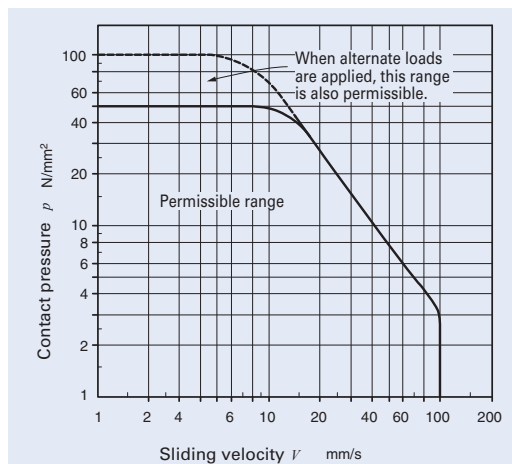
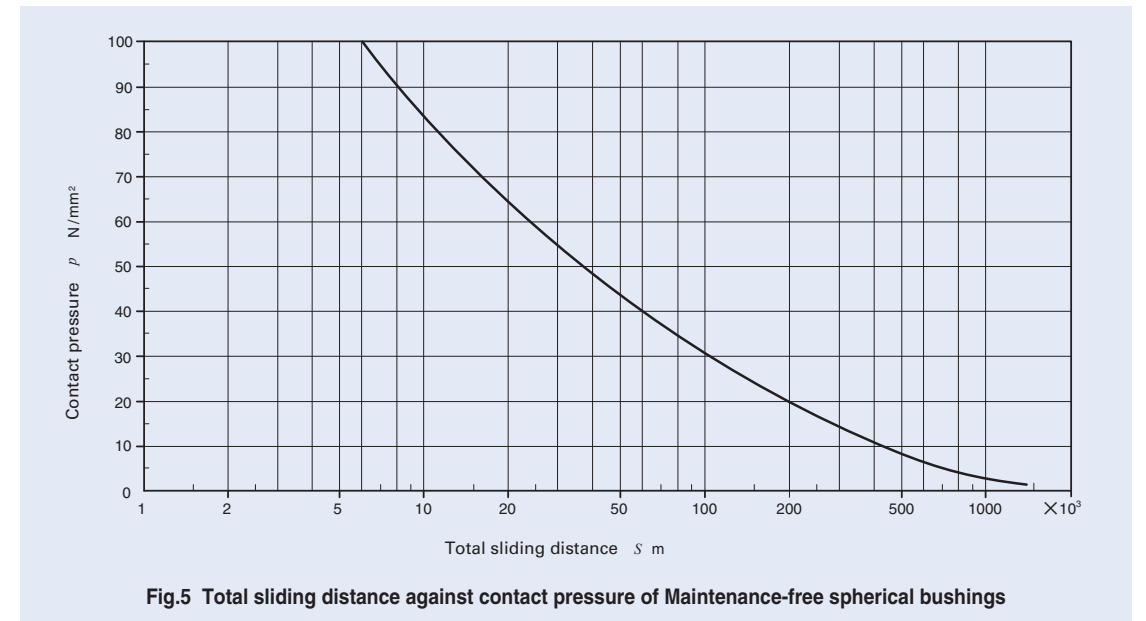

**Fig.4  $pV$  diagram of Maintenance-free spherical bushings**

**Table 14 Load directional factor  $b_1$  (Maintenance-free)**

| Load direction                | Constant | Alternate          |
|-------------------------------|----------|--------------------|
| Load directional factor $b_1$ | 1        | 0.2 <sup>(1)</sup> |

Note<sup>(1)</sup> This value is applicable when the load changes comparatively slowly. When the load changes rapidly, please consult **IKO**, as the factor decreases sharply.



**Fig.5 Total sliding distance against contact pressure of Maintenance-free spherical bushings**

**Lubrication**

Steel-on-steel Spherical Bushings can be operated without lubrication when the magnitude of applied load is small and the sliding velocity of oscillation is small. However, in general, it is necessary to supply grease periodically. During initial operation, it is recommended to shorten the lubrication interval. Lithium soap base grease (NLGI consistency No.2) containing molybdenum disulfide (MoS<sub>2</sub>) is widely used as the lubricating grease.

Maintenance-free Spherical Bushings can be used without lubrication. However, if lithium soap base grease is supplied before operation, the spherical bushings can be operated for an extended period of time. The spherical bushings can be effectively protected from dust and rust if the space around the bushings is filled with grease.

**Oil Hole**

The number of oil holes on inner and outer rings is shown in Table 15.

**Table 15 Number of oil holes on inner and outer rings**

| Bushing type                        |               |                  | Number of oil holes on inner and outer rings |
|-------------------------------------|---------------|------------------|--|
| Steel-on-steel Spherical Bushings   | Metric series | GE...E           | 0  |
|                                     |               | GE...G           |  |
|                                     | Inch series   | SB, SB...A       | 2  |
|                                     |               | GE...ES, GE...GS |  |
| Maintenance-free Spherical Bushings | Metric series | GE...EC          | 0  |

Remark Types with oil holes are also provided with oil grooves on inner and outer rings.



## Operating Temperature Range

The operating temperature range for Spherical Bushings with seals is -30°C~+80°C.

The maximum allowable temperature for Spherical Bushings without seals is +180 °C for the steel-on-steel type and +150 °C for the maintenance-free type.

## Precautions for Use

### Design of shaft

When the load is large, sliding may occur between the shaft and the inner ring bore of bushing. For such cases, it is necessary to prepare the shaft with a hardness of 58HRC or greater and surface roughness of 0.8 μmR<sub>a</sub> or less.

Furthermore, attention must be paid to the strength of shaft because the shear and/or bending stresses in the shaft may surpass the allowable values even when the load is below the static load capacity of Spherical Bushings.

### Design of housing

The housing should have sufficient rigidity to avoid harmful deformation under load.

When the housing shown in Fig.6 is used, it should be designed with sufficient strength as follows.

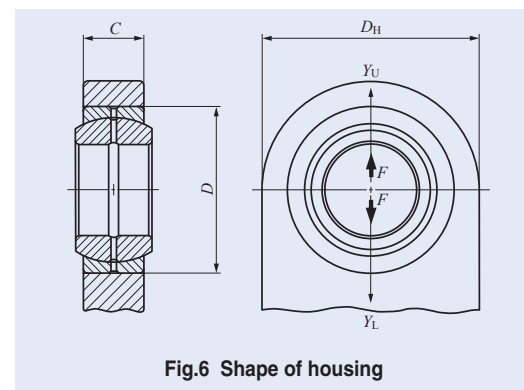

Fig.6 Shape of housing

#### ① When the load acts in the Y<sub>L</sub> direction;

Select the housing material considering the compressive stress obtained from the following formula.

$$\sigma_1 = \frac{F}{CD} \dots\dots\dots(9)$$

where,  $\sigma_1$  : Maximum compressive stress occurring in the housing bore N/mm<sup>2</sup>

F : Applied load N

C : Width of outer ring and housing mm

D : Outside diameter of outer ring mm

#### ② When the load acts in the Yu direction ;

Select the housing material considering the tensile stress obtained from the following formula.

$$\sigma_2 = \frac{F}{C(D_H - D)} k \dots\dots\dots(10)$$

where,  $\sigma_2$  : Maximum tensile stress occurring in the housing bore N/mm<sup>2</sup>

F : Applied load N

C : Width of outer ring and housing mm

D<sub>H</sub> : Outside diameter of housing mm

D : Outside diameter of outer ring mm

k : Stress concentration factor (Refer to Fig.7.)

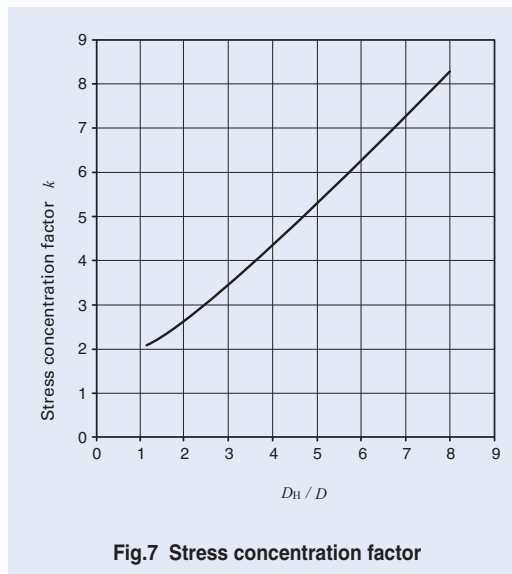

Fig.7 Stress concentration factor

## Mounting

① When mounting Spherical Bushings, pay attention to the location of the split plane of the outer ring. Set the split plane at right angles to the direction of load to avoid the application of load to the split plane as shown in Fig. 8.

② The shoulder dimensions of shaft and housing are shown in the dimension tables.

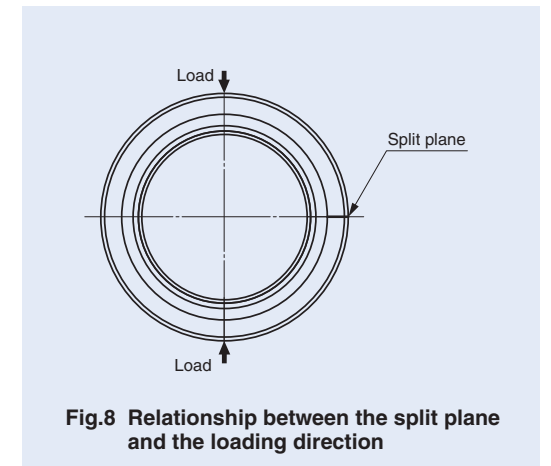

Fig.8 Relationship between the split plane and the loading direction

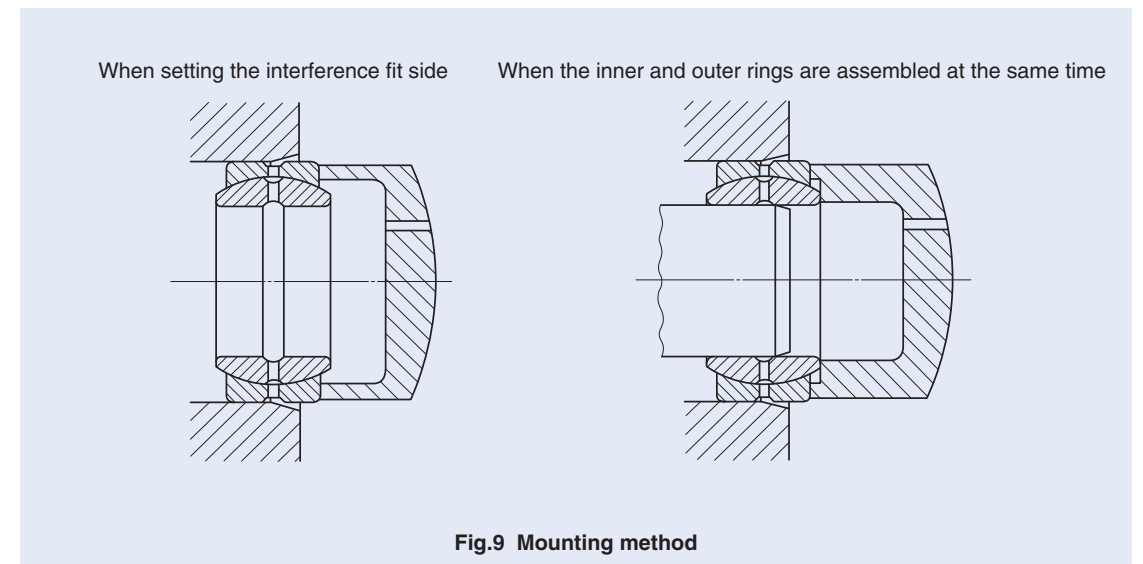

Fig.9 Mounting method

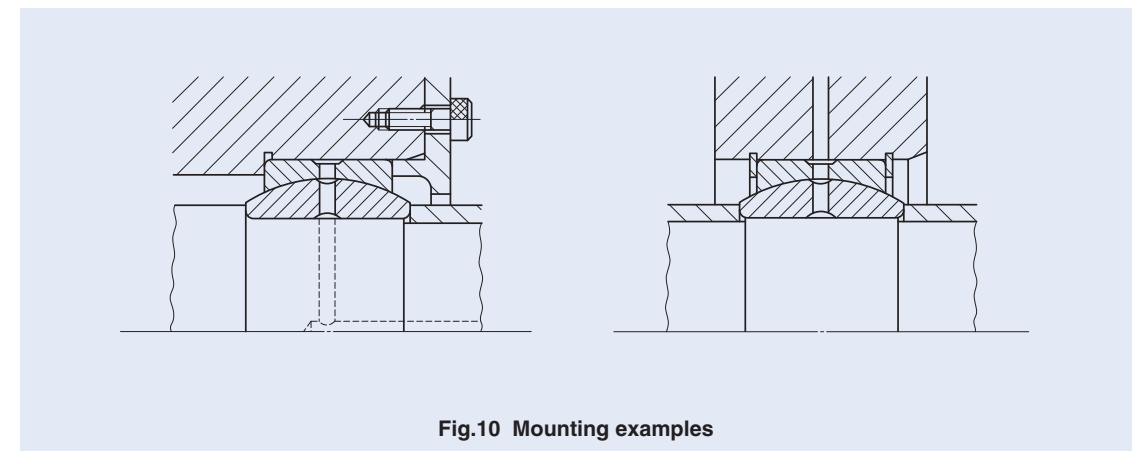

Fig.10 Mounting examples

**SPHERICAL BUSHINGS**

Steel-on-steel Spherical Bushings



Shaft dia. 12 – 100mm

| Shaft dia.<br>mm | Identification number |             | Mass<br>(Ref.)<br>kg | Boundary dimensions<br>mm |     |     |     |       |                           | Permissible<br>tilting angle<br>degree<br>$\alpha$ |
|------------------|-----------------------|-------------|----------------------|---------------------------|-----|-----|-----|-------|---------------------------|--|
|                  |                       |             |                      | $d$                       | $D$ | $B$ | $C$ | $d_k$ | $r_{s \text{ min}}^{(1)}$ |  |
| 12               | SB 12A                | SB 122211   | 0.019                | 12                        | 22  | 11  | 9   | 18    | 0.3                       | 7  |
| 15               | SB 15A                | SB 152613   | 0.028                | 15                        | 26  | 13  | 11  | 22    | 0.3                       | 6  |
| 20               | SB 20A                | SB 203216   | 0.053                | 20                        | 32  | 16  | 14  | 28    | 0.3                       | 4  |
| 22               | SB 22A                | SB 223719   | 0.085                | 22                        | 37  | 19  | 16  | 32    | 0.3                       | 6  |
| 25               | SB 25A                | SB 254221   | 0.116                | 25                        | 42  | 21  | 18  | 36    | 0.3                       | 5  |
| 30               | SB 30A                | SB 305027   | 0.225                | 30                        | 50  | 27  | 23  | 45    | 0.6                       | 6  |
| 35               | SB 35A                | SB 355530   | 0.300                | 35                        | 55  | 30  | 26  | 50    | 0.6                       | 5  |
| 40               | SB 40A                | SB 406233   | 0.375                | 40                        | 62  | 33  | 28  | 55    | 0.6                       | 6  |
| 45               | SB 45A                | SB 457236   | 0.600                | 45                        | 72  | 36  | 31  | 62    | 0.6                       | 5  |
| 50               | SB 50A                | SB 508042   | 0.870                | 50                        | 80  | 42  | 36  | 72    | 0.6                       | 5  |
| 55               | SB 55A                | SB 559047   | 1.26                 | 55                        | 90  | 47  | 40  | 80    | 0.6                       | 5  |
| 60               | SB 60A                | SB 6010053  | 1.70                 | 60                        | 100 | 53  | 45  | 90    | 0.6                       | 6  |
| 65               | SB 65A                | SB 6510555  | 2.05                 | 65                        | 105 | 55  | 47  | 94    | 0.6                       | 5  |
| 70               | SB 70A                | SB 7011058  | 2.22                 | 70                        | 110 | 58  | 50  | 100   | 0.6                       | 5  |
| 75               | SB 75A                | SB 7512064  | 3.02                 | 75                        | 120 | 64  | 55  | 110   | 0.6                       | 5  |
| 80               | SB 80A                | SB 8013070  | 3.98                 | 80                        | 130 | 70  | 60  | 120   | 0.6                       | 5  |
| 85               | SB 85A                | SB 8513574  | 4.29                 | 85                        | 135 | 74  | 63  | 125   | 0.6                       | 6  |
| 90               | SB 90A                | SB 9014076  | 4.71                 | 90                        | 140 | 76  | 65  | 130   | 0.6                       | 5  |
| 95               | SB 95A                | SB 9515082  | 6.05                 | 95                        | 150 | 82  | 70  | 140   | 0.6                       | 5  |
| 100              | SB 100A               | SB 10016088 | 7.42                 | 100                       | 160 | 88  | 75  | 150   | 1                         | 5  |

Notes<sup>(1)</sup> Minimum allowable value of chamfer dimensions  $r_1$  and  $r_2$   
<sup>(2)</sup> When Spherical Bushings are used with full tilting angle, the shaft shoulder dimension must be less than the maximum value of  $d_a$ .  
 Remarks1. The inner ring and the outer ring have an oil groove and two oil holes, respectively.  
 2. No grease is prepacked. Perform proper lubrication.

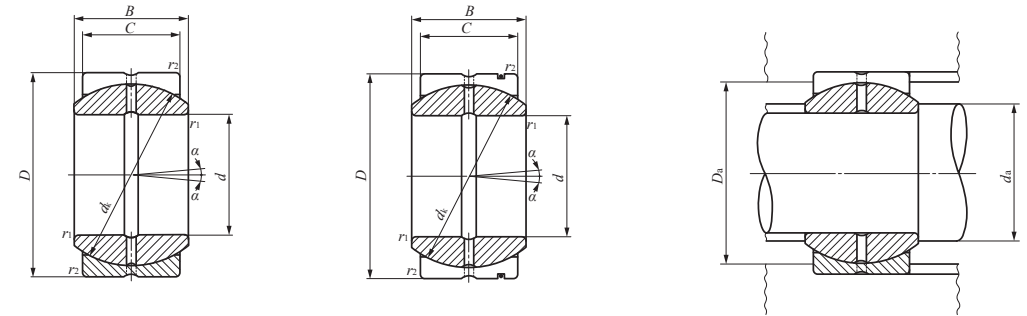

SB...A

SB

| Mounting dimensions<br>mm |                     |       |      | Dynamic load<br>capacity<br>$C_d$<br>N | Static load<br>capacity<br>$C_s$<br>N |
|---------------------------|---------------------|-------|------|--|---------------------------------------|
| $d_a$                     |                     | $D_a$ |      |  |                                       |
| Min.                      | Max. <sup>(2)</sup> | Max.  | Min. |  |                                       |
| 14                        | 14                  | 19.5  | 17   | 15 900                                 | 95 300                                |
| 17.5                      | 17.5                | 23.5  | 21   | 23 700                                 | 142 000                               |
| 22.5                      | 23                  | 29.5  | 26   | 38 400                                 | 231 000                               |
| 24.5                      | 25.5                | 34.5  | 30   | 50 200                                 | 301 000                               |
| 27.5                      | 29                  | 39.5  | 34   | 63 500                                 | 381 000                               |
| 34.5                      | 36                  | 45.5  | 42   | 101 000                                | 609 000                               |
| 39.5                      | 40                  | 50.5  | 46.5 | 127 000                                | 765 000                               |
| 44                        | 44                  | 57.5  | 51.5 | 151 000                                | 906 000                               |
| 49.5                      | 50.5                | 67.5  | 58   | 188 000                                | 1 130 000                             |
| 54.5                      | 58.5                | 75.5  | 67   | 254 000                                | 1 530 000                             |
| 59.5                      | 64.5                | 85.5  | 74.5 | 314 000                                | 1 880 000                             |
| 64.5                      | 72.5                | 95.5  | 83.5 | 397 000                                | 2 380 000                             |
| 69.5                      | 76                  | 100.5 | 87   | 433 000                                | 2 600 000                             |
| 74.5                      | 81.5                | 105.5 | 93   | 490 000                                | 2 940 000                             |
| 79.5                      | 89.5                | 115.5 | 102  | 593 000                                | 3 560 000                             |
| 84.5                      | 97.5                | 125.5 | 112  | 706 000                                | 4 240 000                             |
| 89.5                      | 100.5               | 130.5 | 116  | 772 000                                | 4 630 000                             |
| 94.5                      | 105.5               | 135.5 | 121  | 829 000                                | 4 970 000                             |
| 99.5                      | 113.5               | 145.5 | 130  | 961 000                                | 5 770 000                             |
| 105.5                     | 121.5               | 154.5 | 139  | 1 100 000                              | 6 620 000                             |

**SPHERICAL BUSHINGS**

Steel-on-steel Spherical Bushings



Shaft dia. 110 – 150mm

| Shaft dia.<br>mm | Identification number |                     | Mass<br>(Ref.)<br>kg | Boundary dimensions<br>mm |     |     |     |       |                          | Permissible<br>tilting angle<br>degree<br>$\alpha$ |
|------------------|-----------------------|---------------------|----------------------|---------------------------|-----|-----|-----|-------|--------------------------|--|
|                  |                       |                     |                      | $d$                       | $D$ | $B$ | $C$ | $d_k$ | $r_s$ min <sup>(1)</sup> |  |
| 110              | <b>SB 110A</b>        | <b>SB 11017093</b>  | 8.55                 | 110                       | 170 | 93  | 80  | 160   | 1                        | 5  |
| 115              | <b>SB 115A</b>        | <b>SB 11518098</b>  | 10.3                 | 115                       | 180 | 98  | 85  | 165   | 1                        | 5  |
| 120              | <b>SB 120A</b>        | <b>SB 120190105</b> | 12.4                 | 120                       | 190 | 105 | 90  | 175   | 1                        | 5  |
| 130              | <b>SB 130A</b>        | <b>SB 130200110</b> | 13.8                 | 130                       | 200 | 110 | 95  | 185   | 1                        | 5  |
| 150              | <b>SB 150A</b>        | <b>SB 150220120</b> | 17.0                 | 150                       | 220 | 120 | 105 | 205   | 1                        | 5  |

Notes<sup>(1)</sup> Minimum allowable value of chamfer dimensions  $r_1$  and  $r_2$   
<sup>(2)</sup> When Spherical Bushings are used with full tilting angle, the shaft shoulder dimension must be less than the maximum value of  $d_a$ .  
 Remarks1. The inner ring and the outer ring have an oil groove and two oil holes, respectively.  
 2. No grease is prepacked. Perform proper lubrication.

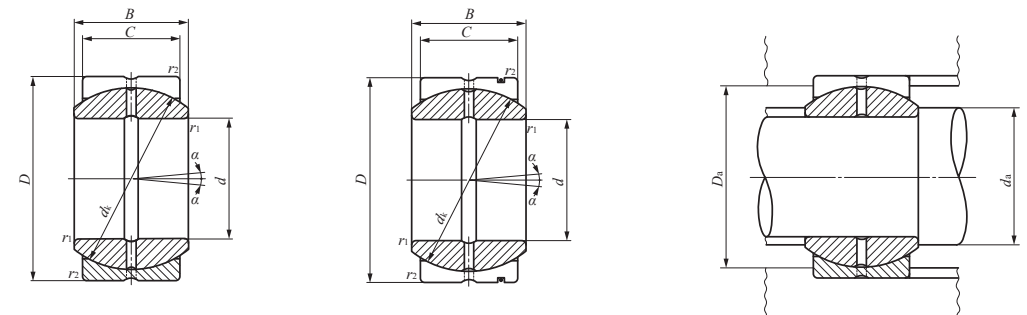

| Mounting dimensions<br>mm |                              |       |               | Dynamic load<br>capacity<br>$C_d$<br>N | Static load<br>capacity<br>$C_s$<br>N |
|---------------------------|------------------------------|-------|---------------|--|---------------------------------------|
| Min.                      | $d_a$<br>Max. <sup>(2)</sup> | Max.  | $D_a$<br>Min. |  |                                       |
| 115.5                     | 130                          | 164.5 | 149           | 1 260 000                              | 7 530 000                             |
| 120.5                     | 132.5                        | 174.5 | 152           | 1 380 000                              | 8 250 000                             |
| 125.5                     | 140                          | 184.5 | 162           | 1 540 000                              | 9 270 000                             |
| 135.5                     | 148.5                        | 194.5 | 171           | 1 720 000                              | 10 300 000                            |
| 155.5                     | 166                          | 214.5 | 189           | 2 110 000                              | 12 700 000                            |

**SPHERICAL BUSHINGS**

Steel-on-steel Spherical Bushings

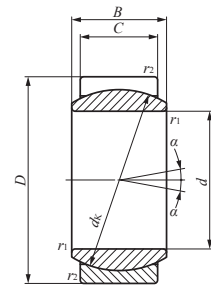

GE...E

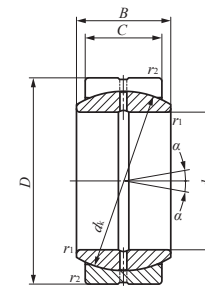

GE...ES

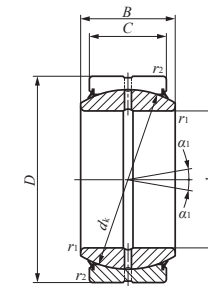

GE...ES-2RS

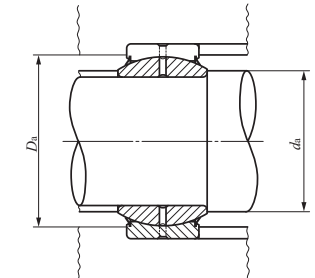

Shaft dia. 4 – 100mm

| Shaft dia.<br>mm | Identification number |              | Mass<br>(Ref.)<br>kg | Boundary dimensions<br>mm |     |    |    |      |                                       |                                       | Permissible<br>tilting angle<br>degree |                |
|------------------|-----------------------|--------------|----------------------|---------------------------|-----|----|----|------|---------------------------------------|---------------------------------------|--|----------------|
|                  | Without seals         | With seals   |                      | d                         | D   | B  | C  | dk   | r <sub>1s</sub> <sup>(1)</sup><br>min | r <sub>2s</sub> <sup>(1)</sup><br>min | α                                      | α <sub>1</sub> |
| 4                | GE 4E                 | —            | 0.003                | 4                         | 12  | 5  | 3  | 8    | 0.3                                   | 0.3                                   | 16                                     | —              |
| 5                | GE 5E                 | —            | 0.004                | 5                         | 14  | 6  | 4  | 10   | 0.3                                   | 0.3                                   | 13                                     | —              |
| 6                | GE 6E                 | —            | 0.004                | 6                         | 14  | 6  | 4  | 10   | 0.3                                   | 0.3                                   | 13                                     | —              |
| 8                | GE 8E                 | —            | 0.008                | 8                         | 16  | 8  | 5  | 13   | 0.3                                   | 0.3                                   | 15                                     | —              |
| 10               | GE 10E                | —            | 0.012                | 10                        | 19  | 9  | 6  | 16   | 0.3                                   | 0.3                                   | 12                                     | —              |
| 12               | GE 12E                | —            | 0.017                | 12                        | 22  | 10 | 7  | 18   | 0.3                                   | 0.3                                   | 11                                     | —              |
| 15               | GE 15ES               | GE 15ES-2RS  | 0.032                | 15                        | 26  | 12 | 9  | 22   | 0.3                                   | 0.3                                   | 8                                      | 5              |
| 17               | GE 17ES               | GE 17ES-2RS  | 0.049                | 17                        | 30  | 14 | 10 | 25   | 0.3                                   | 0.3                                   | 10                                     | 7              |
| 20               | GE 20ES               | GE 20ES-2RS  | 0.065                | 20                        | 35  | 16 | 12 | 29   | 0.3                                   | 0.3                                   | 9                                      | 6              |
| 25               | GE 25ES               | GE 25ES-2RS  | 0.115                | 25                        | 42  | 20 | 16 | 35.5 | 0.6                                   | 0.6                                   | 7                                      | 4              |
| 30               | GE 30ES               | GE 30ES-2RS  | 0.160                | 30                        | 47  | 22 | 18 | 40.7 | 0.6                                   | 0.6                                   | 6                                      | 4              |
| 35               | GE 35ES               | GE 35ES-2RS  | 0.258                | 35                        | 55  | 25 | 20 | 47   | 0.6                                   | 1                                     | 6                                      | 4              |
| 40               | GE 40ES               | GE 40ES-2RS  | 0.315                | 40                        | 62  | 28 | 22 | 53   | 0.6                                   | 1                                     | 7                                      | 4              |
| 45               | GE 45ES               | GE 45ES-2RS  | 0.413                | 45                        | 68  | 32 | 25 | 60   | 0.6                                   | 1                                     | 7                                      | 4              |
| 50               | GE 50ES               | GE 50ES-2RS  | 0.560                | 50                        | 75  | 35 | 28 | 66   | 0.6                                   | 1                                     | 6                                      | 4              |
| 60               | GE 60ES               | GE 60ES-2RS  | 1.10                 | 60                        | 90  | 44 | 36 | 80   | 1                                     | 1                                     | 6                                      | 3              |
| 70               | GE 70ES               | GE 70ES-2RS  | 1.54                 | 70                        | 105 | 49 | 40 | 92   | 1                                     | 1                                     | 6                                      | 4              |
| 80               | GE 80ES               | GE 80ES-2RS  | 2.29                 | 80                        | 120 | 55 | 45 | 105  | 1                                     | 1                                     | 6                                      | 4              |
| 90               | GE 90ES               | GE 90ES-2RS  | 2.82                 | 90                        | 130 | 60 | 50 | 115  | 1                                     | 1                                     | 5                                      | 3              |
| 100              | GE 100ES              | GE 100ES-2RS | 4.43                 | 100                       | 150 | 70 | 55 | 130  | 1                                     | 1                                     | 7                                      | 5              |

Notes<sup>(1)</sup> Minimum allowable value of chamfer dimensions  $r_1$  and  $r_2$   
<sup>(2)</sup> When Spherical Bushings are used with full tilting angle, the shaft shoulder dimension must be less than the maximum value of  $d_a$ .  
 Remarks1. GE...E has no oil hole. Others are provided with an oil groove and two oil holes on the inner ring and outer ring, respectively.  
 2. No grease is prepacked. Perform proper lubrication.

| Mounting dimensions<br>mm |                     |       |      | Dynamic load<br>capacity<br>$C_d$<br>N | Static load<br>capacity<br>$C_s$<br>N |
|---------------------------|---------------------|-------|------|--|---------------------------------------|
| $d_a$                     |                     | $D_a$ |      |  |                                       |
| Min.                      | Max. <sup>(2)</sup> | Max.  | Min. |  |                                       |
| 6                         | 6                   | 9.5   | 8    | 2 350                                  | 14 100                                |
| 7.5                       | 8                   | 11.5  | 10   | 3 920                                  | 23 500                                |
| 8                         | 8                   | 11.5  | 10   | 3 920                                  | 23 500                                |
| 10                        | 10                  | 13.5  | 13   | 6 370                                  | 38 200                                |
| 12.5                      | 13                  | 16.5  | 15.5 | 9 410                                  | 56 500                                |
| 14.5                      | 15                  | 19.5  | 17   | 12 400                                 | 74 100                                |
| 17.5                      | 18                  | 23.5  | 22.5 | 19 400                                 | 117 000                               |
| 19.5                      | 20.5                | 27.5  | 26   | 24 500                                 | 147 000                               |
| 22.5                      | 24                  | 32.5  | 30.5 | 34 100                                 | 205 000                               |
| 29                        | 29                  | 37.5  | 37   | 55 700                                 | 334 000                               |
| 34                        | 34                  | 42.5  | 41.5 | 71 800                                 | 431 000                               |
| 39.5                      | 39.5                | 49.5  | 48   | 92 200                                 | 553 000                               |
| 44.5                      | 45                  | 56.5  | 54.5 | 114 000                                | 686 000                               |
| 49.5                      | 50.5                | 62.5  | 60   | 147 000                                | 883 000                               |
| 54.5                      | 56                  | 69.5  | 66   | 181 000                                | 1 090 000                             |
| 65.5                      | 66.5                | 84.5  | 79   | 282 000                                | 1 690 000                             |
| 75.5                      | 77.5                | 99.5  | 91   | 361 000                                | 2 170 000                             |
| 85.5                      | 89                  | 114.5 | 103  | 463 000                                | 2 780 000                             |
| 95.5                      | 98                  | 124.5 | 112  | 564 000                                | 3 380 000                             |
| 105.5                     | 109.5               | 144.5 | 127  | 701 000                                | 4 210 000                             |



**SPHERICAL BUSHINGS**

Steel-on-steel Spherical Bushings

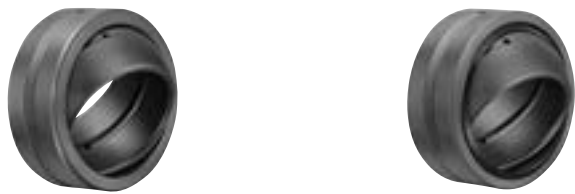

Shaft dia. 110 – 300mm

| Shaft dia.<br>mm | Identification number |                     | Mass<br>(Ref.)<br>kg | Boundary dimensions<br>mm |     |     |     |       |                     |                     | Permissible<br>tilting angle<br>degree |            |
|------------------|-----------------------|---------------------|----------------------|---------------------------|-----|-----|-----|-------|---------------------|---------------------|--|------------|
|                  | Without seals         | With seals          |                      | $d$                       | $D$ | $B$ | $C$ | $d_k$ | $r_{1s \min}^{(1)}$ | $r_{2s \min}^{(1)}$ | $\alpha$                               | $\alpha_1$ |
| 110              | <b>GE 110ES</b>       | <b>GE 110ES-2RS</b> | 4.94                 | 110                       | 160 | 70  | 55  | 140   | 1                   | 1                   | 6                                      | 4          |
| 120              | <b>GE 120ES</b>       | <b>GE 120ES-2RS</b> | 8.12                 | 120                       | 180 | 85  | 70  | 160   | 1                   | 1                   | 6                                      | 4          |
| 140              | <b>GE 140ES</b>       | <b>GE 140ES-2RS</b> | 11.4                 | 140                       | 210 | 90  | 70  | 180   | 1                   | 1                   | 7                                      | 5          |
| 160              | <b>GE 160ES</b>       | <b>GE 160ES-2RS</b> | 14.4                 | 160                       | 230 | 105 | 80  | 200   | 1                   | 1                   | 8                                      | 6          |
| 180              | <b>GE 180ES</b>       | <b>GE 180ES-2RS</b> | 18.9                 | 180                       | 260 | 105 | 80  | 225   | 1.1                 | 1.1                 | 6                                      | 5          |
| 200              | <b>GE 200ES</b>       | <b>GE 200ES-2RS</b> | 28.1                 | 200                       | 290 | 130 | 100 | 250   | 1.1                 | 1.1                 | 7                                      | 6          |
| 220              | <b>GE 220ES</b>       | <b>GE 220ES-2RS</b> | 36.1                 | 220                       | 320 | 135 | 100 | 275   | 1.1                 | 1.1                 | 8                                      | 6          |
| 240              | <b>GE 240ES</b>       | <b>GE 240ES-2RS</b> | 40.4                 | 240                       | 340 | 140 | 100 | 300   | 1.1                 | 1.1                 | 8                                      | 6          |
| 260              | <b>GE 260ES</b>       | <b>GE 260ES-2RS</b> | 52.0                 | 260                       | 370 | 150 | 110 | 325   | 1.1                 | 1.1                 | 7                                      | 6          |
| 280              | <b>GE 280ES</b>       | <b>GE 280ES-2RS</b> | 66.0                 | 280                       | 400 | 155 | 120 | 350   | 1.1                 | 1.1                 | 6                                      | 5          |
| 300              | <b>GE 300ES</b>       | <b>GE 300ES-2RS</b> | 76.0                 | 300                       | 430 | 165 | 120 | 375   | 1.1                 | 1.1                 | 7                                      | 6          |

Notes<sup>(1)</sup> Minimum allowable value of chamfer dimensions  $r_1$  and  $r_2$   
<sup>(2)</sup> When Spherical Bushings are used with full tilting angle, the shaft shoulder dimension must be less than the maximum value of  $d_a$ .  
 Remarks1. The inner ring and the outer ring have an oil groove and two oil holes, respectively.  
 2. No grease is prepacked. Perform proper lubrication.

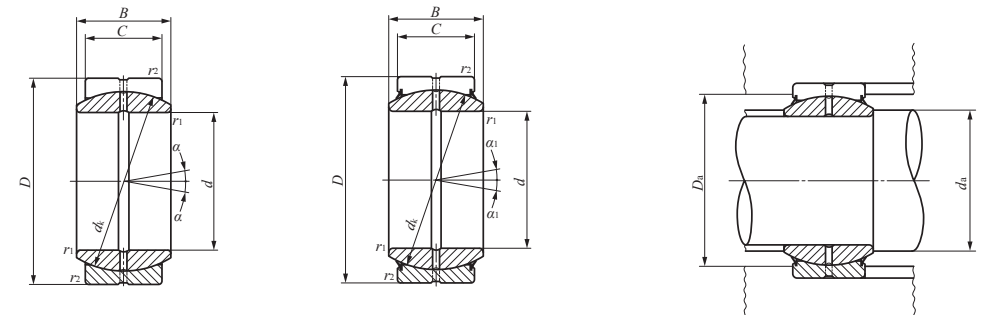

GE...ES

GE...ES-2RS

| Mounting dimensions<br>mm |                     |       |      | Dynamic load<br>capacity<br>$C_d$<br>N | Static load<br>capacity<br>$C_s$<br>N |
|---------------------------|---------------------|-------|------|--|---------------------------------------|
| $d_a$                     |                     | $D_a$ |      |  |                                       |
| Min.                      | Max. <sup>(2)</sup> | Max.  | Min. |  |                                       |
| 115.5                     | 121                 | 154.5 | 138  | 755 000                                | 4 530 000                             |
| 125.5                     | 135.5               | 174.5 | 154  | 1 100 000                              | 6 590 000                             |
| 145.5                     | 155.5               | 204.5 | 176  | 1 240 000                              | 7 410 000                             |
| 165.5                     | 170                 | 224.5 | 195  | 1 570 000                              | 9 410 000                             |
| 187                       | 199                 | 253   | 221  | 1 770 000                              | 10 600 000                            |
| 207                       | 213.5               | 283   | 244  | 2 450 000                              | 14 700 000                            |
| 227                       | 239.5               | 313   | 269  | 2 700 000                              | 16 200 000                            |
| 247                       | 265                 | 333   | 296  | 2 940 000                              | 17 700 000                            |
| 267                       | 288                 | 363   | 320  | 3 510 000                              | 21 000 000                            |
| 287                       | 313.5               | 393   | 345  | 4 120 000                              | 24 700 000                            |
| 307                       | 336.5               | 423   | 371  | 4 410 000                              | 26 500 000                            |

**SPHERICAL BUSHINGS**

Steel-on-steel Spherical Bushings

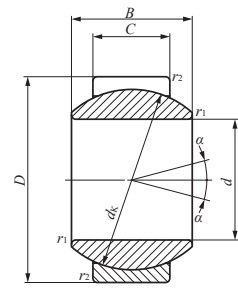

GE...G

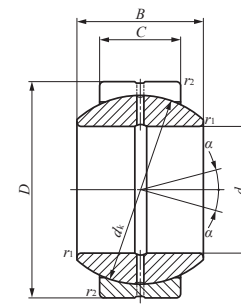

GE...GS

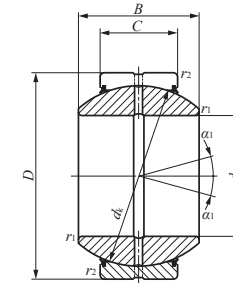

GE...GS-2RS

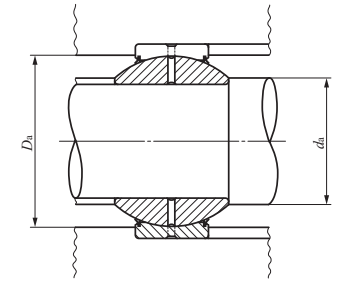

Shaft dia. 6 – 120mm

| Shaft dia.<br>mm | Identification number |              | Mass<br>(Ref.)<br>kg | Boundary dimensions<br>mm |     |     |    |                |                                    |                                    | Permissible<br>tilting angle<br>degree |                |
|------------------|-----------------------|--------------|----------------------|---------------------------|-----|-----|----|----------------|------------------------------------|------------------------------------|--|----------------|
|                  | Without seals         | With seals   |                      | d                         | D   | B   | C  | d <sub>k</sub> | r <sub>1s min</sub> <sup>(1)</sup> | r <sub>2s min</sub> <sup>(1)</sup> | α                                      | α <sub>1</sub> |
| 6                | GE 6G                 | —            | 0.010                | 6                         | 16  | 9   | 5  | 13             | 0.3                                | 0.3                                | 21                                     | —              |
| 8                | GE 8G                 | —            | 0.015                | 8                         | 19  | 11  | 6  | 16             | 0.3                                | 0.3                                | 21                                     | —              |
| 10               | GE 10G                | —            | 0.022                | 10                        | 22  | 12  | 7  | 18             | 0.3                                | 0.3                                | 18                                     | —              |
| 12               | GE 12G                | —            | 0.041                | 12                        | 26  | 15  | 9  | 22             | 0.3                                | 0.3                                | 18                                     | —              |
| 15               | GE 15GS               | GE 15GS-2RS  | 0.059                | 15                        | 30  | 16  | 10 | 25             | 0.3                                | 0.3                                | 16                                     | 13             |
| 17               | GE 17GS               | GE 17GS-2RS  | 0.083                | 17                        | 35  | 20  | 12 | 29             | 0.3                                | 0.3                                | 19                                     | 16             |
| 20               | GE 20GS               | GE 20GS-2RS  | 0.155                | 20                        | 42  | 25  | 16 | 35.5           | 0.3                                | 0.6                                | 17                                     | 16             |
| 25               | GE 25GS               | GE 25GS-2RS  | 0.215                | 25                        | 47  | 28  | 18 | 40.7           | 0.6                                | 0.6                                | 17                                     | 15             |
| 30               | GE 30GS               | GE 30GS-2RS  | 0.330                | 30                        | 55  | 32  | 20 | 47             | 0.6                                | 1                                  | 17                                     | 16             |
| 35               | GE 35GS               | GE 35GS-2RS  | 0.400                | 35                        | 62  | 35  | 22 | 53             | 0.6                                | 1                                  | 16                                     | 15             |
| 40               | GE 40GS               | GE 40GS-2RS  | 0.515                | 40                        | 68  | 40  | 25 | 60             | 0.6                                | 1                                  | 17                                     | 14             |
| 45               | GE 45GS               | GE 45GS-2RS  | 0.660                | 45                        | 75  | 43  | 28 | 66             | 0.6                                | 1                                  | 15                                     | 13             |
| 50               | GE 50GS               | GE 50GS-2RS  | 1.50                 | 50                        | 90  | 56  | 36 | 80             | 0.6                                | 1                                  | 17                                     | 16             |
| 60               | GE 60GS               | GE 60GS-2RS  | 2.05                 | 60                        | 105 | 63  | 40 | 92             | 1                                  | 1                                  | 17                                     | 15             |
| 70               | GE 70GS               | GE 70GS-2RS  | 3.00                 | 70                        | 120 | 70  | 45 | 105            | 1                                  | 1                                  | 16                                     | 14             |
| 80               | GE 80GS               | GE 80GS-2RS  | 3.60                 | 80                        | 130 | 75  | 50 | 115            | 1                                  | 1                                  | 14                                     | 13             |
| 90               | GE 90GS               | GE 90GS-2RS  | 5.41                 | 90                        | 150 | 85  | 55 | 130            | 1                                  | 1                                  | 15                                     | 14             |
| 100              | GE 100GS              | GE 100GS-2RS | 6.15                 | 100                       | 160 | 85  | 55 | 140            | 1                                  | 1                                  | 14                                     | 12             |
| 110              | GE 110GS              | GE 110GS-2RS | 9.70                 | 110                       | 180 | 100 | 70 | 160            | 1                                  | 1                                  | 12                                     | 11             |
| 120              | GE 120GS              | GE 120GS-2RS | 15.5                 | 120                       | 210 | 115 | 70 | 180            | 1                                  | 1                                  | 16                                     | 15             |

Notes<sup>(1)</sup> Minimum allowable value of chamfer dimensions  $r_1$  and  $r_2$   
<sup>(2)</sup> When Spherical Bushings are used with full tilting angle, the shaft shoulder dimension must be less than the maximum value of  $d_a$ .  
 Remarks1. GE...G has no oil hole. Others are provided with an oil groove and two oil holes on the inner ring and outer ring, respectively.  
 2. No grease is prepacked. Perform proper lubrication.

| Mounting dimensions<br>mm |                     |       |      | Dynamic load<br>capacity<br>$C_d$<br>N | Static load<br>capacity<br>$C_s$<br>N |
|---------------------------|---------------------|-------|------|--|---------------------------------------|
| Min.                      | Max. <sup>(2)</sup> | Max.  | Min. |  |                                       |
| 8.5                       | 9                   | 13.5  | 13   | 6 370                                  | 38 200                                |
| 10.5                      | 11.5                | 16.5  | 15.5 | 9 410                                  | 56 500                                |
| 12.5                      | 13                  | 19.5  | 17   | 12 400                                 | 74 100                                |
| 14.5                      | 16                  | 23.5  | 21   | 19 400                                 | 117 000                               |
| 17.5                      | 19                  | 27.5  | 26   | 24 500                                 | 147 000                               |
| 19.5                      | 21                  | 32.5  | 30.5 | 34 100                                 | 205 000                               |
| 22.5                      | 25                  | 37.5  | 37   | 55 700                                 | 334 000                               |
| 29.5                      | 29.5                | 42.5  | 41.5 | 71 800                                 | 431 000                               |
| 34                        | 34                  | 49.5  | 48   | 92 200                                 | 553 000                               |
| 39.5                      | 39.5                | 56.5  | 54.5 | 114 000                                | 686 000                               |
| 44.5                      | 44.5                | 62.5  | 60   | 147 000                                | 883 000                               |
| 49.5                      | 50                  | 69.5  | 66   | 181 000                                | 1 090 000                             |
| 54.5                      | 57                  | 84.5  | 79   | 282 000                                | 1 690 000                             |
| 65.5                      | 67                  | 99.5  | 91   | 361 000                                | 2 170 000                             |
| 75.5                      | 78                  | 114.5 | 103  | 463 000                                | 2 780 000                             |
| 85.5                      | 87                  | 124.5 | 112  | 564 000                                | 3 380 000                             |
| 95.5                      | 98                  | 144.5 | 127  | 701 000                                | 4 210 000                             |
| 105.5                     | 111                 | 154.5 | 138  | 755 000                                | 4 530 000                             |
| 115.5                     | 124.5               | 174.5 | 154  | 1 100 000                              | 6 590 000                             |
| 125.5                     | 138.5               | 204.5 | 176  | 1 240 000                              | 7 410 000                             |

**SPHERICAL BUSHINGS**

Steel-on-steel Spherical Bushings



Shaft dia. 140 – 280mm

| Shaft dia.<br>mm | Identification number |              | Mass<br>(Ref.)<br>kg | Boundary dimensions<br>mm |     |     |     |       |                     |                     | Permissible<br>tilting angle<br>degree |            |
|------------------|-----------------------|--------------|----------------------|---------------------------|-----|-----|-----|-------|---------------------|---------------------|--|------------|
|                  | Without seals         | With seals   |                      | $d$                       | $D$ | $B$ | $C$ | $d_k$ | $r_{1s \min}^{(1)}$ | $r_{2s \min}^{(1)}$ | $\alpha$                               | $\alpha_1$ |
| 140              | GE 140GS              | GE 140GS-2RS | 19.2                 | 140                       | 230 | 130 | 80  | 200   | 1                   | 1                   | 16                                     | 15         |
| 160              | GE 160GS              | GE 160GS-2RS | 25.4                 | 160                       | 260 | 135 | 80  | 225   | 1                   | 1.1                 | 16                                     | 14         |
| 180              | GE 180GS              | GE 180GS-2RS | 34.7                 | 180                       | 290 | 155 | 100 | 250   | 1.1                 | 1.1                 | 14                                     | 13         |
| 200              | GE 200GS              | GE 200GS-2RS | 43.8                 | 200                       | 320 | 165 | 100 | 275   | 1.1                 | 1.1                 | 15                                     | 14         |
| 220              | GE 220GS              | GE 220GS-2RS | 51.3                 | 220                       | 340 | 175 | 100 | 300   | 1.1                 | 1.1                 | 16                                     | 14         |
| 240              | GE 240GS              | GE 240GS-2RS | 66.1                 | 240                       | 370 | 190 | 110 | 325   | 1.1                 | 1.1                 | 15                                     | 14         |
| 260              | GE 260GS              | GE 260GS-2RS | 81.8                 | 260                       | 400 | 205 | 120 | 350   | 1.1                 | 1.1                 | 15                                     | 14         |
| 280              | GE 280GS              | GE 280GS-2RS | 97.4                 | 280                       | 430 | 210 | 120 | 375   | 1.1                 | 1.1                 | 15                                     | 14         |

Notes<sup>(1)</sup> Minimum allowable value of chamfer dimensions  $r_1$  and  $r_2$   
<sup>(2)</sup> When Spherical Bushings are used with full tilting angle, the shaft shoulder dimension must be less than the maximum value of  $d_a$ .  
 Remarks1. The inner ring and the outer ring have an oil groove and two oil holes, respectively.  
 2. No grease is prepacked. Perform proper lubrication.

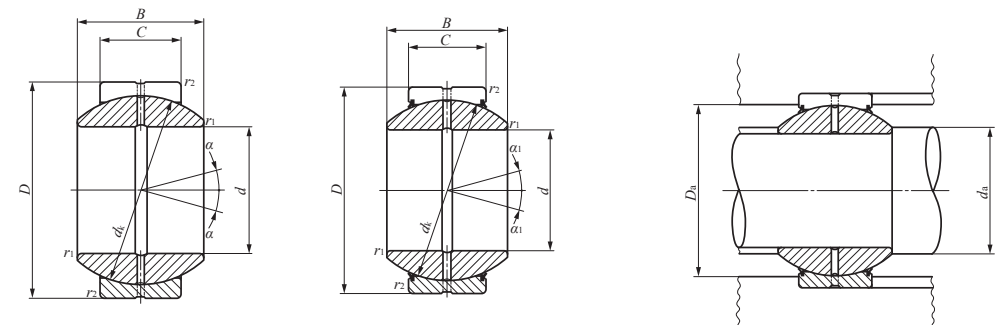

GE...GS

GE...GS-2RS

| Mounting dimensions<br>mm |                     |       |      | Dynamic load<br>capacity<br>$C_d$<br>N | Static load<br>capacity<br>$C_s$<br>N |
|---------------------------|---------------------|-------|------|--|---------------------------------------|
| $d_a$                     |                     | $D_a$ |      |  |                                       |
| Min.                      | Max. <sup>(2)</sup> | Max.  | Min. |  |                                       |
| 145.5                     | 152                 | 224.5 | 195  | 1 570 000                              | 9 410 000                             |
| 165.5                     | 180                 | 253   | 221  | 1 770 000                              | 10 600 000                            |
| 187                       | 196                 | 283   | 244  | 2 450 000                              | 14 700 000                            |
| 207                       | 220                 | 313   | 269  | 2 700 000                              | 16 200 000                            |
| 227                       | 243.5               | 333   | 296  | 2 940 000                              | 17 700 000                            |
| 247                       | 263.5               | 363   | 320  | 3 510 000                              | 21 000 000                            |
| 267                       | 283.5               | 393   | 345  | 4 120 000                              | 24 700 000                            |
| 287                       | 310.5               | 423   | 371  | 4 410 000                              | 26 500 000                            |

**SPHERICAL BUSHINGS**

Steel-on-steel Spherical Bushings **Inch Series**



Shaft dia. 12.700 – 63.500mm

| Shaft dia.<br>mm<br>(inch) | Identification number |                   | Mass<br>(Ref.)<br>kg | Boundary dimensions<br>mm(inch) |                   |              |              |
|----------------------------|-----------------------|-------------------|----------------------|---------------------------------|-------------------|--------------|--------------|
|                            | Without seal          | With seals        |                      | <i>d</i>                        | <i>D</i>          | <i>B</i>     | <i>C</i>     |
| <b>12.700</b><br>(1/2)     | <b>SBB 8</b>          | —                 | 0.020                | 12.700 (1/2)                    | 22.225 (7/8)      | 11.10(.437)  | 9.52(.375)   |
| <b>15.875</b><br>(5/8)     | <b>SBB 10</b>         | —                 | 0.036                | 15.875 (5/8)                    | 26.988 (1 1/16)   | 13.89(.547)  | 11.91(.469)  |
| <b>19.050</b><br>(3/4)     | <b>SBB 12</b>         | <b>SBB 12-2RS</b> | 0.057                | 19.050 (3/4)                    | 31.750 (1 1/4)    | 16.66(.656)  | 14.27(.562)  |
| <b>22.225</b><br>(7/8)     | <b>SBB 14</b>         | <b>SBB 14-2RS</b> | 0.088                | 22.225 (7/8)                    | 36.512 (1 7/16)   | 19.43(.765)  | 16.66(.656)  |
| <b>25.400</b><br>(1)       | <b>SBB 16</b>         | <b>SBB 16-2RS</b> | 0.125                | 25.400 (1)                      | 41.275 (1 5/8)    | 22.22(.875)  | 19.05(.750)  |
| <b>31.750</b><br>(1 1/4)   | <b>SBB 20</b>         | <b>SBB 20-2RS</b> | 0.234                | 31.750 (1 1/4)                  | 50.800 (2)        | 27.76(1.093) | 23.80(.937)  |
| <b>34.925</b><br>(1 3/8)   | <b>SBB 22</b>         | <b>SBB 22-2RS</b> | 0.349                | 34.925 (1 3/8)                  | 55.562 (2 3/16)   | 30.15(1.187) | 26.19(1.031) |
| <b>38.100</b><br>(1 1/2)   | <b>SBB 24</b>         | <b>SBB 24-2RS</b> | 0.424                | 38.100 (1 1/2)                  | 61.912 (2 7/16)   | 33.32(1.312) | 28.58(1.125) |
| <b>44.450</b><br>(1 3/4)   | <b>SBB 28</b>         | <b>SBB 28-2RS</b> | 0.649                | 44.450 (1 3/4)                  | 71.438 (2 13/16)  | 38.89(1.531) | 33.32(1.312) |
| <b>50.800</b><br>(2)       | <b>SBB 32</b>         | <b>SBB 32-2RS</b> | 0.939                | 50.800 (2)                      | 80.962 (3 3/16)   | 44.45(1.750) | 38.10(1.500) |
| <b>57.150</b><br>(2 1/4)   | <b>SBB 36</b>         | <b>SBB 36-2RS</b> | 1.32                 | 57.150 (2 1/4)                  | 90.488 (3 9/16)   | 50.01(1.969) | 42.85(1.687) |
| <b>63.500</b><br>(2 1/2)   | <b>SBB 40</b>         | <b>SBB 40-2RS</b> | 1.85                 | 63.500 (2 1/2)                  | 100.012 (3 15/16) | 55.55(2.187) | 47.62(1.875) |

Note(1) Maximum allowable corner radius of the shaft or housing  
 Remarks1. The value with mark \* is applicable to types without seals. For types with seals, the value is 0.4 mm.  
 2. The inner ring and the outer ring have an oil groove and two oil holes, respectively.  
 3. No grease is prepacked. Perform proper lubrication.

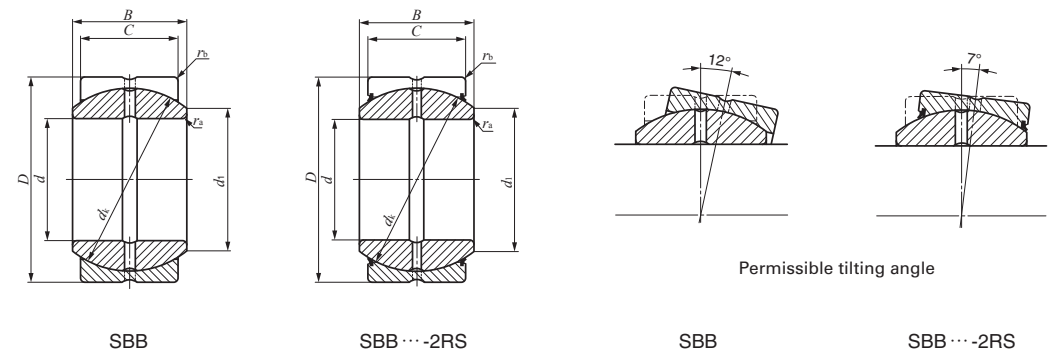

| <i>d<sub>k</sub></i> | Radial internal clearance<br>mm<br>Min./Max. | Mounting dimensions<br>mm |   |   | Dynamic load capacity<br><i>C<sub>d</sub></i><br>N | Static load capacity<br><i>C<sub>s</sub></i><br>N |
|----------------------|--|---------------------------|---|---|--|---|
|                      |  | <i>d<sub>1</sub></i>      | <sup>(1)</sup><br><i>r<sub>as</sub> max</i><br>Max. | <sup>(1)</sup><br><i>r<sub>bs</sub> max</i><br>Max. |  |   |
| 18 (.709)            | 0.05 / 0.15                                  | 14.0                      | 0.2   | 0.6   | 16 800   | 101 000   |
| 23 (.906)            | 0.05 / 0.15                                  | 17.9                      | 0.2   | 0.8   | 26 900   | 161 000   |
| 27.5(1.083)          | 0.08 / 0.18                                  | 21.4                      | 0.6   | *0.8  | 38 500   | 231 000   |
| 32 (1.260)           | 0.08 / 0.18                                  | 25.0                      | 0.6   | *0.8  | 52 300   | 314 000   |
| 36 (1.417)           | 0.08 / 0.18                                  | 28.0                      | 0.6   | *0.8  | 67 300   | 404 000   |
| 45 (1.772)           | 0.08 / 0.18                                  | 35.1                      | 0.6   | 0.8   | 105 000  | 630 000   |
| 49 (1.929)           | 0.08 / 0.18                                  | 38.5                      | 0.6   | 0.8   | 126 000  | 755 000   |
| 55 (2.165)           | 0.08 / 0.18                                  | 43.3                      | 0.6   | 0.8   | 154 000  | 925 000   |
| 64 (2.520)           | 0.08 / 0.18                                  | 50.4                      | 0.6   | 0.8   | 209 000  | 1 250 000   |
| 73 (2.874)           | 0.08 / 0.18                                  | 57.6                      | 0.6   | 0.8   | 273 000  | 1 640 000   |
| 82 (3.228)           | 0.10 / 0.20                                  | 64.9                      | 0.6   | 0.8   | 345 000  | 2 070 000   |
| 91 (3.583)           | 0.10 / 0.20                                  | 72.0                      | 0.6   | 0.8   | 425 000  | 2 550 000   |

**SPHERICAL BUSHINGS**

Steel-on-steel Spherical Bushings **Inch Series**

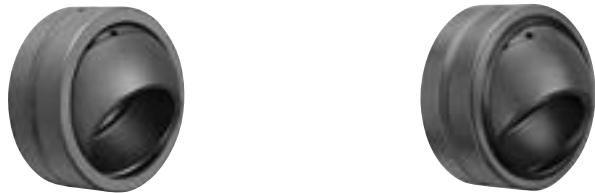

Shaft dia. 69.850 – 152.400mm

| Shaft dia.<br>mm<br>(inch) | Identification number |                   | Mass<br>(Ref.)<br>kg | Boundary dimensions<br>mm(inch) |              |               |               |
|----------------------------|-----------------------|-------------------|----------------------|---------------------------------|--------------|---------------|---------------|
|                            | Without seal          | With seals        |                      | <i>d</i>                        | <i>D</i>     | <i>B</i>      | <i>C</i>      |
| <b>69.850</b><br>(2¾)      | <b>SBB 44</b>         | <b>SBB 44-2RS</b> | 2.44                 | 69.850 (2¾)                     | 111.125 (4¾) | 61.11(2.406)  | 52.37(2.062)  |
| <b>76.200</b><br>(3)       | <b>SBB 48</b>         | <b>SBB 48-2RS</b> | 3.12                 | 76.200 (3)                      | 120.650 (4¾) | 66.68(2.625)  | 57.15(2.250)  |
| <b>82.550</b><br>(3¼)      | <b>SBB 52</b>         | <b>SBB 52-2RS</b> | 3.92                 | 82.550 (3¼)                     | 130.175 (5¼) | 72.24(2.844)  | 61.90(2.437)  |
| <b>88.900</b><br>(3½)      | <b>SBB 56</b>         | <b>SBB 56-2RS</b> | 4.83                 | 88.900 (3½)                     | 139.700 (5½) | 77.77(3.062)  | 66.68(2.625)  |
| <b>95.250</b><br>(3¾)      | <b>SBB 60</b>         | <b>SBB 60-2RS</b> | 5.87                 | 95.250 (3¾)                     | 149.225 (5¾) | 83.34(3.281)  | 71.42(2.812)  |
| <b>101.600</b><br>(4)      | <b>SBB 64</b>         | <b>SBB 64-2RS</b> | 7.07                 | 101.600 (4)                     | 158.750 (6¼) | 88.90(3.500)  | 76.20(3.000)  |
| <b>107.950</b><br>(4¼)     | <b>SBB 68</b>         | <b>SBB 68-2RS</b> | 8.46                 | 107.950 (4¼)                    | 168.275 (6⅝) | 94.46(3.719)  | 80.95(3.187)  |
| <b>114.300</b><br>(4½)     | <b>SBB 72</b>         | <b>SBB 72-2RS</b> | 9.94                 | 114.300 (4½)                    | 177.800 (7)  | 100.00(3.937) | 85.72(3.375)  |
| <b>120.650</b><br>(4¾)     | <b>SBB 76</b>         | <b>SBB 76-2RS</b> | 11.6                 | 120.650 (4¾)                    | 187.325 (7¾) | 105.56(4.156) | 90.47(3.562)  |
| <b>127.000</b><br>(5)      | <b>SBB 80</b>         | <b>SBB 80-2RS</b> | 13.5                 | 127.000 (5)                     | 196.850 (7¾) | 111.12(4.375) | 95.25(3.750)  |
| <b>152.400</b><br>(6)      | <b>SBB 96</b>         | <b>SBB 96-2RS</b> | 17.6                 | 152.400 (6)                     | 222.250 (8¾) | 120.65(4.750) | 104.78(4.125) |

Note(1) Maximum allowable corner radius of the shaft or housing  
 Remarks1. The inner ring and the outer ring have an oil groove and two oil holes, respectively.  
 2. No grease is prepacked. Perform proper lubrication.

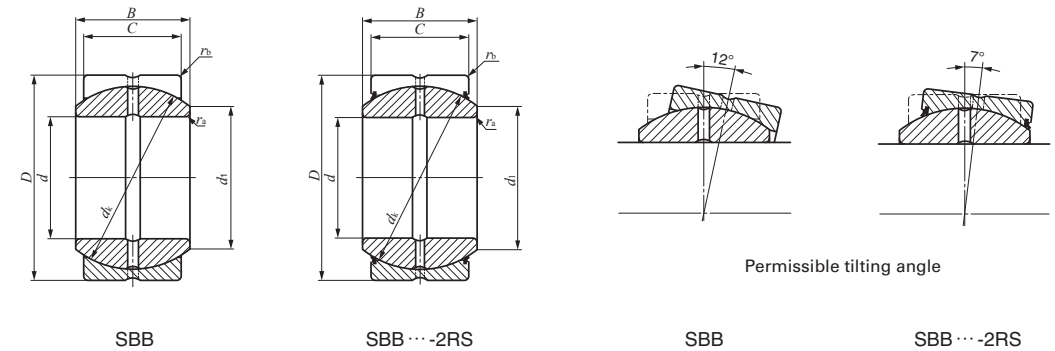

| <i>d<sub>k</sub></i> | Radial internal clearance<br>mm<br>Min./Max. | Mounting dimensions<br>mm |   |   | Dynamic load capacity<br><i>C<sub>d</sub></i><br>N | Static load capacity<br><i>C<sub>s</sub></i><br>N |
|----------------------|--|---------------------------|---|---|--|---|
|                      |  | <i>d<sub>1</sub></i>      | <sup>(1)</sup><br><i>r<sub>as</sub> max</i><br>Max. | <sup>(1)</sup><br><i>r<sub>bs</sub> max</i><br>Max. |  |   |
| 100(3.937)           | 0.10 / 0.20                                  | 79.0                      | 0.6   | 0.8   | 514 000  | 3 080 000   |
| 110(4.331)           | 0.10 / 0.20                                  | 86.5                      | 0.6   | 0.8   | 616 000  | 3 700 000   |
| 119(4.685)           | 0.13 / 0.23                                  | 94.1                      | 0.6   | 0.8   | 722 000  | 4 330 000   |
| 128(5.039)           | 0.13 / 0.23                                  | 101.6                     | 0.6   | 0.8   | 837 000  | 5 020 000   |
| 137(5.394)           | 0.13 / 0.23                                  | 108.4                     | 0.6   | 0.8   | 960 000  | 5 760 000   |
| 146(5.748)           | 0.13 / 0.23                                  | 115.8                     | 0.6   | 0.8   | 1 090 000  | 6 550 000   |
| 155(6.102)           | 0.13 / 0.23                                  | 122.6                     | 0.8   | 1.1   | 1 230 000  | 7 380 000   |
| 164(6.457)           | 0.13 / 0.23                                  | 129.8                     | 0.8   | 1.1   | 1 380 000  | 8 270 000   |
| 173(6.811)           | 0.13 / 0.23                                  | 136.8                     | 0.8   | 1.1   | 1 530 000  | 9 210 000   |
| 183(7.205)           | 0.13 / 0.23                                  | 144.9                     | 0.8   | 1.1   | 1 710 000  | 10 300 000  |
| 207(8.150)           | 0.13 / 0.23                                  | 167.5                     | 0.8   | 1.1   | 2 130 000  | 12 800 000  |

**K**  
SB  
GE  
SBB



**SPHERICAL BUSHINGS**

Maintenance-free Spherical Bushings



Shaft dia. 15 – 70mm

| Shaft dia.<br>mm | Identification number |                    | Mass<br>(Ref.)<br>kg | Boundary dimensions<br>mm |     |     |     |       |                     |                     | Permissible<br>tilting angle<br>degree |            |
|------------------|-----------------------|--------------------|----------------------|---------------------------|-----|-----|-----|-------|---------------------|---------------------|--|------------|
|                  | Without seals         | With seals         |                      | $d$                       | $D$ | $B$ | $C$ | $d_k$ | $r_{1s \min}^{(1)}$ | $r_{2s \min}^{(1)}$ | $\alpha$                               | $\alpha_1$ |
| 15               | <b>GE 15EC</b>        | —                  | 0.032                | 15                        | 26  | 12  | 9   | 22    | 0.3                 | 0.3                 | 8                                      | —          |
| 17               | <b>GE 17EC</b>        | —                  | 0.049                | 17                        | 30  | 14  | 10  | 25    | 0.3                 | 0.3                 | 10                                     | —          |
| 20               | <b>GE 20EC</b>        | —                  | 0.065                | 20                        | 35  | 16  | 12  | 29    | 0.3                 | 0.3                 | 9                                      | —          |
| 25               | <b>GE 25EC</b>        | —                  | 0.115                | 25                        | 42  | 20  | 16  | 35.5  | 0.6                 | 0.6                 | 7                                      | —          |
| 30               | <b>GE 30EC</b>        | <b>GE 30EC-2RS</b> | 0.160                | 30                        | 47  | 22  | 18  | 40.7  | 0.6                 | 0.6                 | 6                                      | 4          |
| 35               | —                     | <b>GE 35EC-2RS</b> | 0.258                | 35                        | 55  | 25  | 20  | 47    | 0.6                 | 1                   | —                                      | 4          |
| 40               | —                     | <b>GE 40EC-2RS</b> | 0.315                | 40                        | 62  | 28  | 22  | 53    | 0.6                 | 1                   | —                                      | 4          |
| 45               | —                     | <b>GE 45EC-2RS</b> | 0.413                | 45                        | 68  | 32  | 25  | 60    | 0.6                 | 1                   | —                                      | 4          |
| 50               | —                     | <b>GE 50EC-2RS</b> | 0.560                | 50                        | 75  | 35  | 28  | 66    | 0.6                 | 1                   | —                                      | 4          |
| 60               | —                     | <b>GE 60EC-2RS</b> | 1.10                 | 60                        | 90  | 44  | 36  | 80    | 1                   | 1                   | —                                      | 3          |
| 70               | —                     | <b>GE 70EC-2RS</b> | 1.54                 | 70                        | 105 | 49  | 40  | 92    | 1                   | 1                   | —                                      | 4          |

Notes<sup>(1)</sup> Minimum allowable value of chamfer dimensions  $r_1$  and  $r_2$

<sup>(2)</sup> When Spherical Bushings are used with full tilting angle, the shaft shoulder dimension must be less than the maximum value of  $d_a$ .

Remark No oil hole is provided.

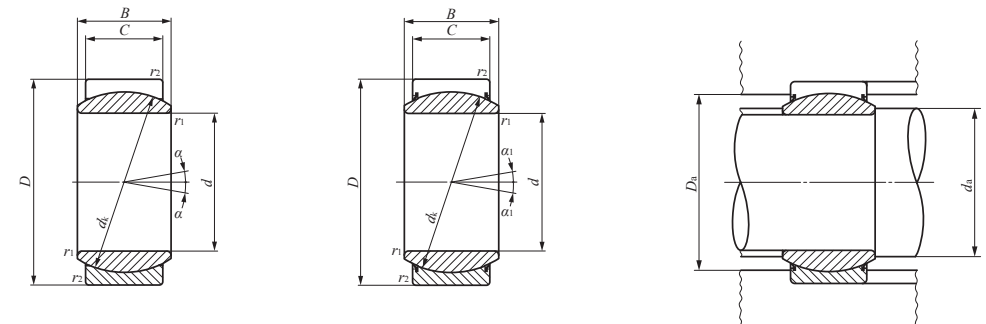

GE...EC

GE...EC-2RS

| Mounting dimensions<br>mm |                     |       |      | Dynamic load<br>capacity<br>$C_d$<br>N | Static load<br>capacity<br>$C_s$<br>N |
|---------------------------|---------------------|-------|------|--|---------------------------------------|
| $d_a$                     |                     | $D_a$ |      |  |                                       |
| Min.                      | Max. <sup>(2)</sup> | Max.  | Min. |  |                                       |
| 17.5                      | 18                  | 23.5  | 21.5 | 19 400                                 | 48 500                                |
| 19.5                      | 20.5                | 27.5  | 24.5 | 24 500                                 | 61 300                                |
| 22.5                      | 24                  | 32.5  | 28   | 34 100                                 | 85 300                                |
| 29                        | 29                  | 37.5  | 34   | 55 700                                 | 139 000                               |
| 34                        | 34                  | 42.5  | 41.5 | 71 800                                 | 180 000                               |
| 39.5                      | 39.5                | 49.5  | 48   | 92 200                                 | 230 000                               |
| 44.5                      | 45                  | 56.5  | 54.5 | 114 000                                | 286 000                               |
| 49.5                      | 50.5                | 62.5  | 60   | 147 000                                | 368 000                               |
| 54.5                      | 56                  | 69.5  | 66   | 181 000                                | 453 000                               |
| 65.5                      | 66.5                | 84.5  | 79   | 282 000                                | 706 000                               |
| 75.5                      | 77.5                | 99.5  | 91   | 361 000                                | 902 000                               |