

SA...DE

SA...DE/X

SA...DE/S

SA...DE

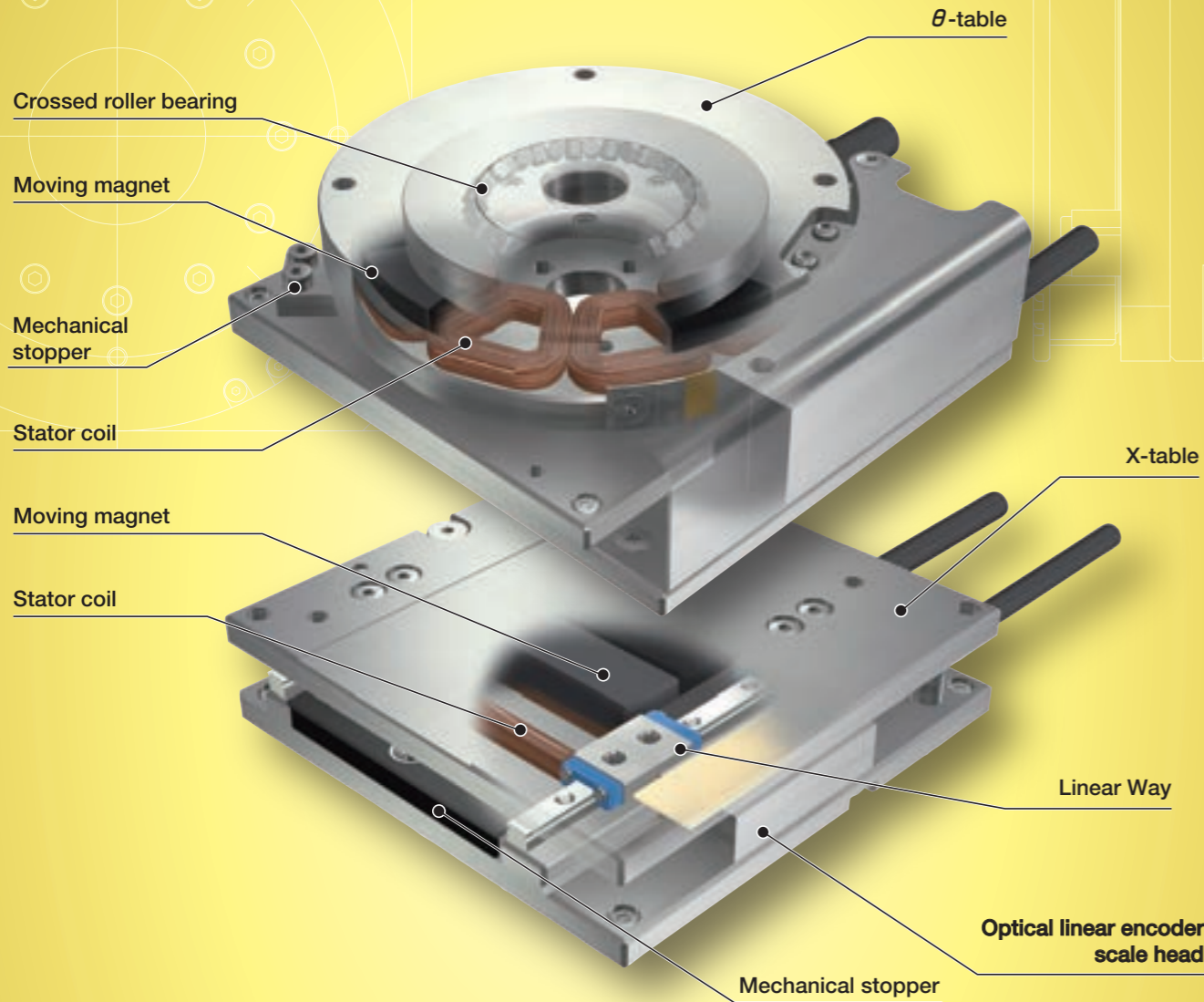

Major product specifications

Driving method	Linear motor
Linear motion rolling guide and bearing	XY-axis: Linear Way (ball type) θ-axis: Crossed Roller Bearing
Lubrication	Lubrication part "C-Lube" is built-in (except for θ-axis and SA65DE/X)
Material of table and bed	High carbon steel
Sensor	Provided as standard

Accuracy

unit: mm

Positioning repeatability	XY-axis: ±0.0005 θ-axis: ±0.5 ~ 1.3 sec
Positioning accuracy	-
Lost motion	-
Parallelism in table motion A	-
Parallelism in table motion B	-
Attitude accuracy	-
Straightness	-
Backlash	-

Points

1 Compact XYθ-table

Using a Linear Way L miniature linear motion rolling guide in the linear motion guiding parts and Crossed Roller Bearing in the rotation guiding parts respectively and adopting direct drive method in the drive section, this is an alignment stage for achieving low profile and compact XYθ motion.

2 Flexible combination of XYθ

X-table for linear movement and θ-table serving as rotary positioning section are listed on lineup as basic configuration. Combination of X-axis and θ-axis and alignment table for XY-axis can be easily configured.

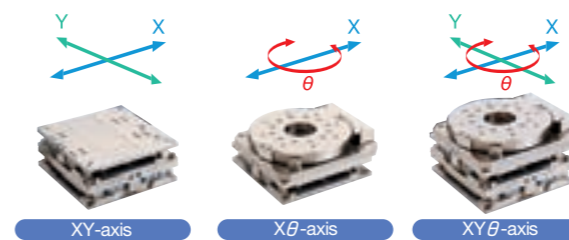

3 Thin and compact

Coreless linear motor, Linear Way L and Crossed Roller Bearing are adopted. As compared with ball screw-driven stage, extremely low profile is achieved.

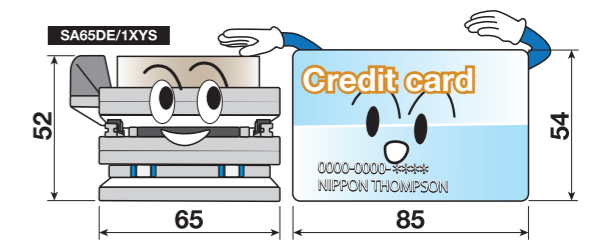

4 High resolution and high responsiveness

Performing full-closed loop control of direct drive-type stage with high resolution linear encoder built-in has achieved high resolution and high accuracy.

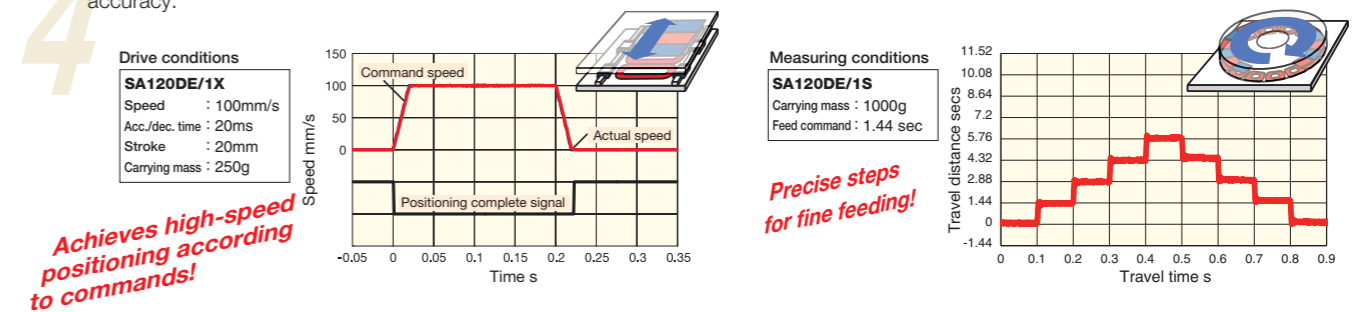

Alignment Stage SA specification list

Model and size	SA65DE/X	SA120DE/X	SA200DE/X	SA65DE/S	SA120DE/S	SA200DE/S
Sectional shape						
Maximum thrust N	25	70	400 (250)	Max. torque 0.5N·m	Max. torque 2.0N·m	Max. torque 8.0 (6.0)N·m
Rated thrust N	3.5	15	70	Rated torque 0.06N·m	Rated torque 0.4N·m	Rated torque 2.0N·m
Maximum load mass kg	2.4	5.9	30.0 (20.0)	2.2	6.8	21.2 (17.1)
Effective stroke length mm	10	20	20	Effective operating angle 50degree	Effective operating angle 60degree	Effective operating angle 280degree
Resolution μm	0.1	0.5	0.1	0.1	0.5	0.1
Maximum speed mm/s	270	500	270	800	270	800
Positioning repeatability μm	±0.5	±0.5	±0.5	±1.3sec	±0.8sec	±0.5sec

Remark: Numbers in parentheses indicate values when used with an ADVA-R5ML driver.

1N=0.102kgf=0.2248lbs.
1mm=0.03937inch

Identification Number

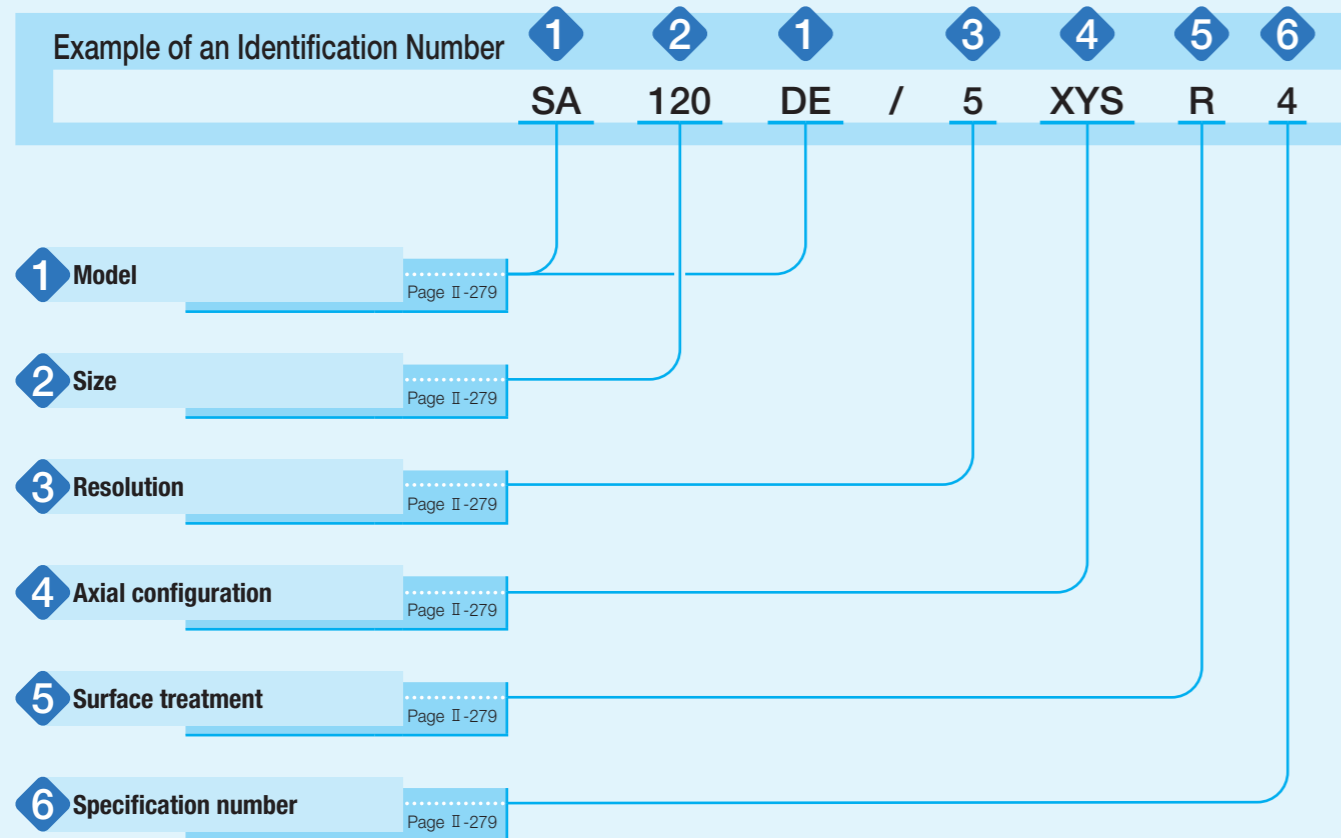

Identification Number and Specification

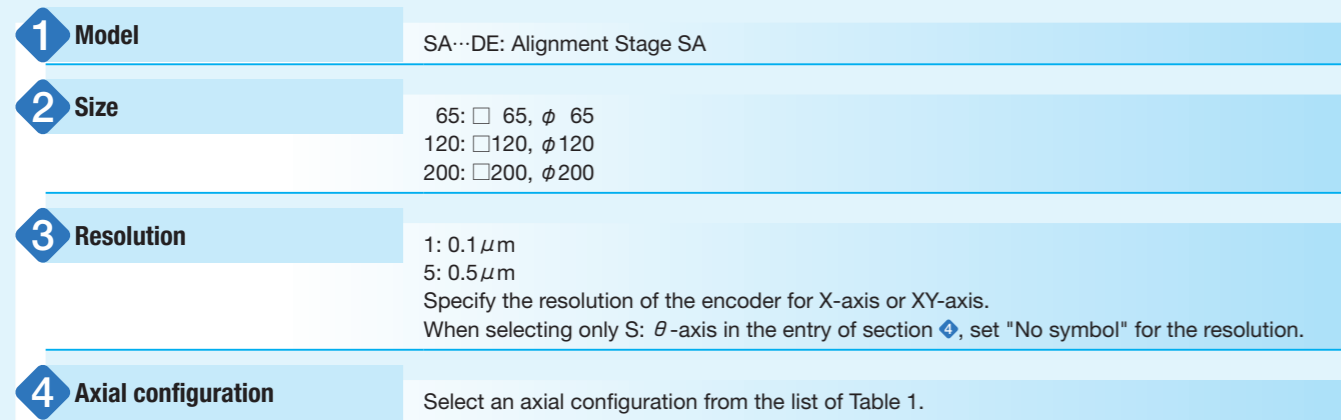
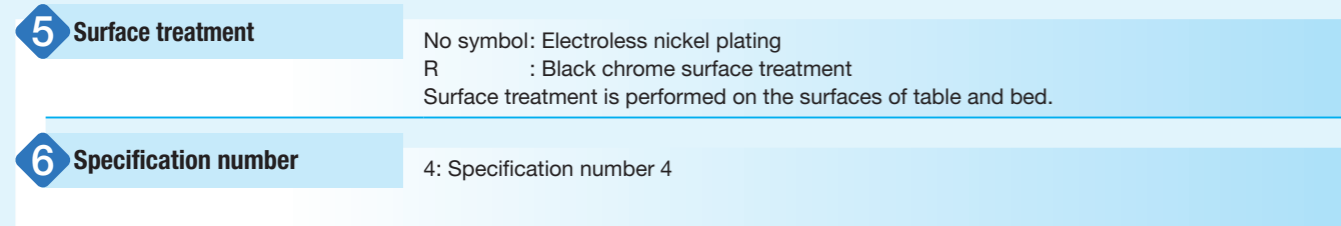

Table 1 Axial configuration and application

Axial configuration	SA65DE	SA120DE	SA200DE
X : Only X-axis	○	○	○
S : Only θ-axis	○	○	○
XY : XY-based two-axis configuration	○	○	○
XS : Xθ-based two-axis configuration	○	○	○
XYS : X, Y, and θ-based three-axis configuration	○	○	○



Specifications

Table 2.1 Specification / Performance

Identification number		SA65DE/1X	SA65DE/5X	SA120DE/1X	SA120DE/5X	SA200DE/1X ⁽⁸⁾	SA200DE/5X ⁽⁸⁾
Maximum thrust ⁽¹⁾	N	25		70		400 (250)	
Rated thrust ⁽²⁾	N	3.5		15 ⁽⁷⁾		70	
Effective stroke length	mm	10		20		20	
Maximum load mass	kg	2.4		5.9		30.0 (20.0)	
Resolution	μm	0.1	0.5	0.1	0.5	0.1	0.5
Maximum speed ⁽³⁾⁽⁴⁾	mm/s	270	500	270	800	270	800
Positioning repeatability ⁽⁵⁾	μm	±0.5					
Mass of moving table	kg	0.17		1.2		3.4	
Total mass ⁽⁶⁾	kg	0.35		2.5		7.2	
Ambient temperature and humidity in operation		0~40°C · 20~80%RH (keep dewdrop free)					

Notes (1) The duration of maximum thrust is up to 1 second.
 (2) This is based on the case of mounting on a metal mating member material at an ambient temperature of 20°C.
 (3) For the case of exceeding the displayed speed, please contact IKO.
 (4) This maximum speed may not be reached depending on the maximum output frequency of the controller used, and the driver type or settings.
 (5) When the temperature of the product is constant.
 (6) Mass of the cord is not included.
 (7) The rated thrust applies within the effective stroke range.
 (8) Numbers in parentheses indicate values when used with an ADVA-R5ML driver.

Table 2.2 Specification / Performance

Identification number		SA65DE/S	SA120DE/S	SA200DE/S ⁽⁷⁾
Maximum torque ⁽¹⁾	N·m	0.5	2.0	8.0 (6.0)
Rated torque ⁽²⁾	N·m	0.06	0.4	2.0
Maximum load mass	kg	2.2	6.8	21.2 (17.1)
Effective operating angle	degree	50	60	280
Resolution	sec	0.64	0.36	0.25
	pulse/degree	5 625	10 000	14 400
Maximum speed ⁽³⁾⁽⁴⁾	degree/sec	720	400	270
Positioning repeatability ⁽⁵⁾	sec	±1.3	±0.8	±0.5
Inertia moment of moving table	kg·m ²	0.00012	0.002	0.013
Total mass ⁽⁶⁾	kg	0.5	2	6
Ambient temperature and humidity in operation		0~40°C · 20~80%RH (keep dewdrop free)		

Notes (1) The duration of maximum torque is up to 1 second.
 (2) This is based on the case of mounting on a metal mating member material at an ambient temperature of 20°C.
 (3) For the case of exceeding the displayed speed, please contact IKO.
 (4) This maximum speed may not be reached depending on the maximum output frequency of the controller used, and the driver type or settings.
 (5) When the temperature of the product is constant.
 (6) Mass of the cord is not included.
 (7) Numbers in parentheses indicate values when used with an ADVA-R5ML driver.

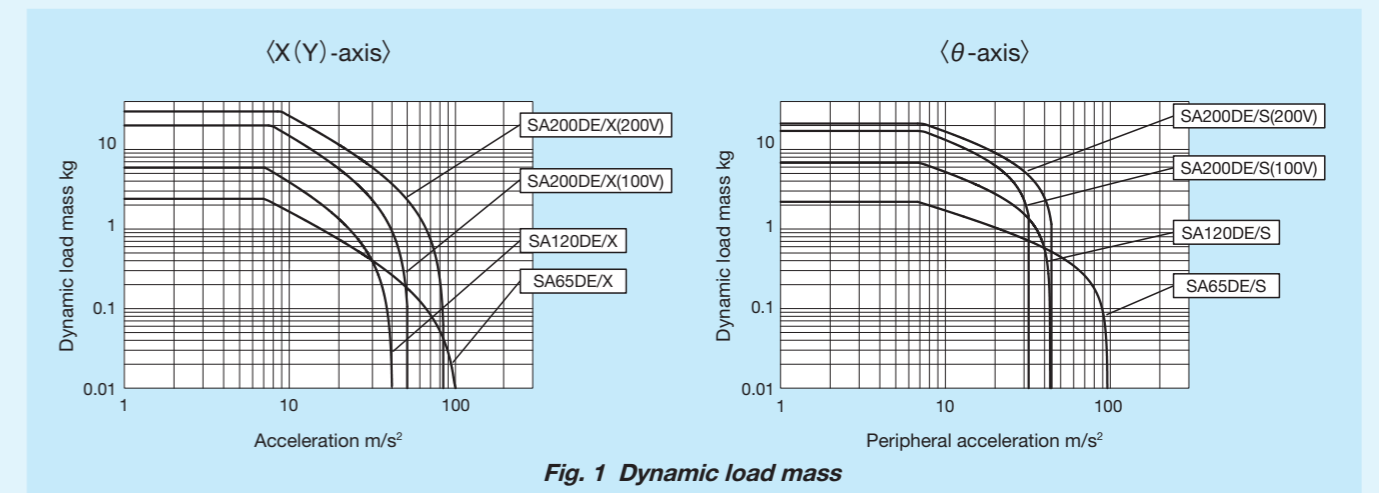

Fig. 1 Dynamic load mass

Remark: Dynamic load mass of θ-axis is a value calculated as cube of steel. And, the acceleration is converted as value of stage periphery.

Mounting

For the processing accuracy of the Precision Positioning Table mounting surface and the tightening torque of the fixing screws, see page III-36.

Sensor Specification

Table 3.1 Sensor timing chart for SA...DE/X (X-axis)

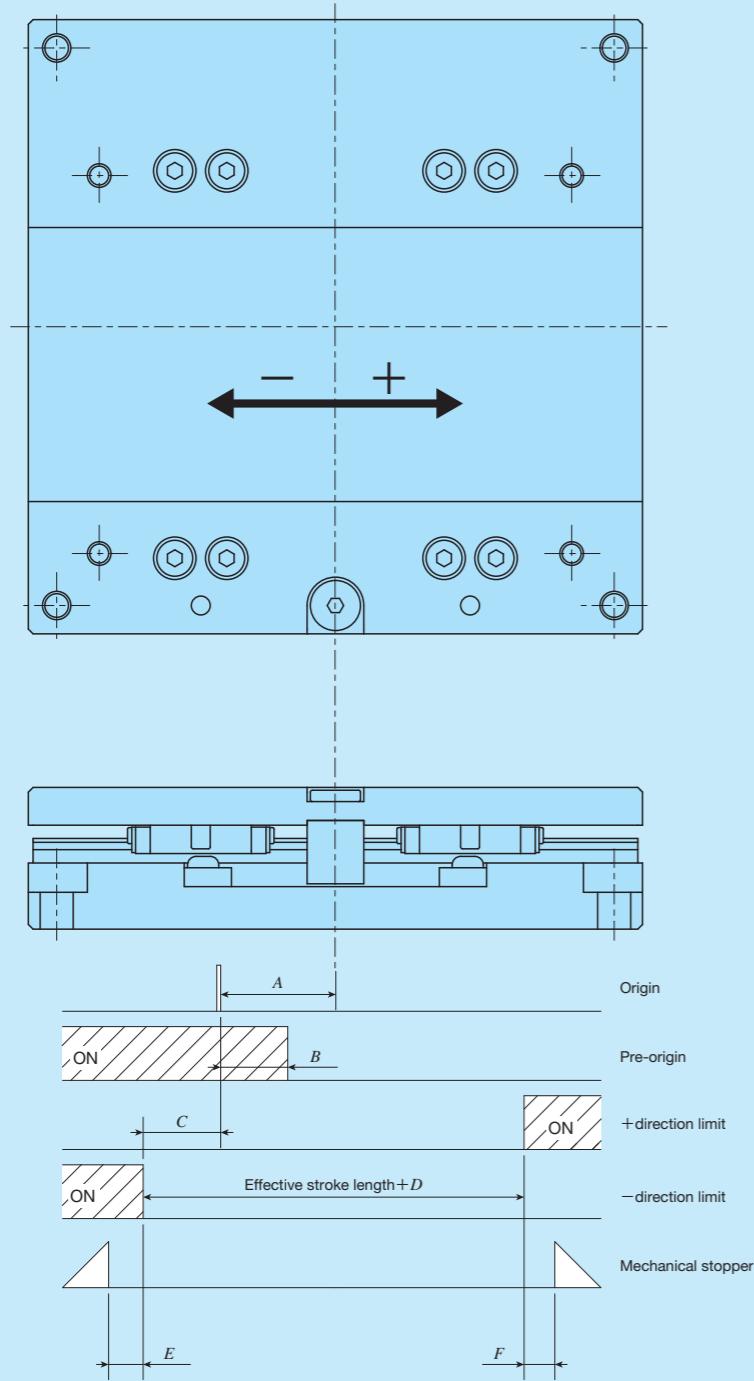

Model and size	A	B	C	D	E	F
SA65DE/X	5	2.5	1.5	3	1.5	1.5
SA120DE/X	0	3	12	4	2	2
SA200DE/X	0	4	10	0	5	5

Remarks 1. Respective values are for reference and are not guaranteed values. For detailed dimensions, please contact IKO.
2. For detailed specifications of respective sensors, please see the section of sensor specification in General Explanation.

Sensor Specification

Table 3.2 Sensor timing chart for SA...DE/S (θ -axis)

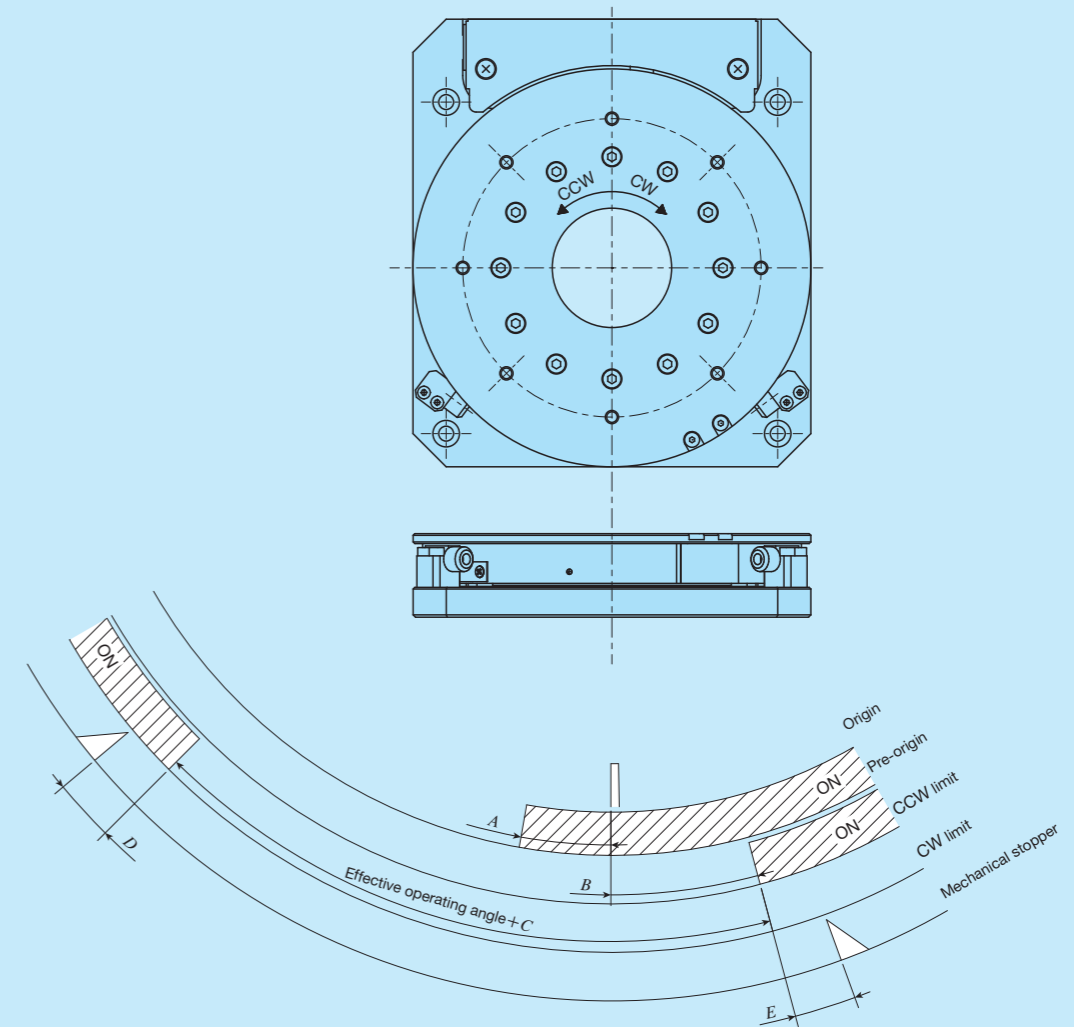

Model and size	A	B	C	D	E
SA65DE/S	4	11	10	5	5
SA120DE/S	3	3	6	3	3
SA200DE/S	2	4	0	4	4

Remarks 1. Respective values are for reference and are not guaranteed values. For detailed dimensions, please contact IKO.
2. For detailed specifications of respective sensors, please see the section of sensor specification in General Explanation.

System Configuration

Two series of dedicated drivers, ADVA and MR-J4, are available for the Alignment Stage SA, and the system configuration varies depending on the driver used. For ADVA, two types of specification, pulse train specification and high speed network EtherCAT specification, are available. For MR-J4, only high speed network SSCNET III/H specification is available. Table 4 shows the example of identification number for ADVA, and Table 5 shows the tables and model number of applicable MR-J4. For detailed driver specification, please see the driver specification on page II-371 to II-375.

Table 4 Identification number for ADVA

ADVA - 01NL EC / SA65DE-S			
(1) Model	(2) Power supply voltage	(3) Command type	(4) Applicable alignment stage model
01NL	Single-phase / Three-phase 200 V	No symbol	SA65DE -S
R5ML	Single-phase 100 V	EC	SA65DE -X
			SA120DE -S
			SA120DE -X
			SA200DE -S2
			SA200DE -X

Table 5 Identification numbers of SA...DE and applicable MR-J4

Identification number of table	Identification number of driver
SA65DE /S	MR-J4-10B-RJ /SA65DE -S
SA65DE /X	MR-J4-10B-RJ /SA65DE -X
SA120DE /S	MR-J4-10B-RJ /SA120DE -S
SA120DE /X	MR-J4-10B-RJ /SA120DE -X
SA200DE /S	MR-J4-10B-RJ /SA200DE -S2
SA200DE /X	MR-J4-10B-RJ /SA200DE -X

Table 6 System configuration for SA65DE, SA120DE with driver ADVA

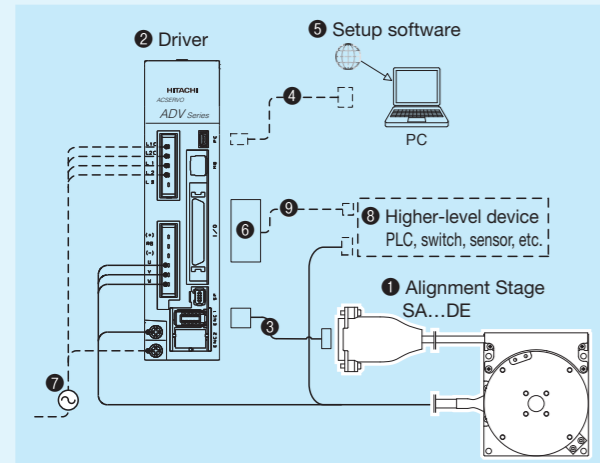

No.	Name	Identification Number
3	Encoder extension cord (2m) ⁽¹⁾	TAE20V4-EC02
4	PC connection cable	USB mini B cable This must be prepared by customer.
5	Setup software	ProDriveNext Please download from the official website of Hitachi Industrial Equipment Systems Co., Ltd.
6	I/O connector	TAE20R5-CN ⁽²⁾
7	Power cord	This must be prepared by customer.
8	Higher-level device	
9	I/O connector connection cable	

Notes ⁽¹⁾ For specific cord length, please contact IKO.
⁽²⁾ I/O connector TAE20R5-CN is a combined product of 10150-3000PE (connector) and 10350-52F0-008 (cover) from 3M Japan Limited.

Table 7 System configuration for SA200DE with driver ADVA

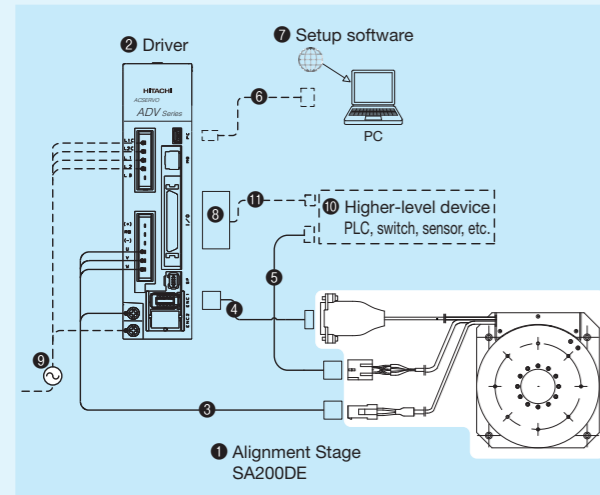

No.	Name	Identification Number
3	Motor extension cord (3m) ⁽¹⁾	TAE20V3-AM03
4	Encoder extension cord (2m) ⁽¹⁾	TAE20V4-EC02
5	Sensor extension cord ⁽²⁾	TAE10V8-LC□□
6	PC connection cable	USB mini B cable This must be prepared by customer.
7	Setup software	ProDriveNext Please download from the official website of Hitachi Industrial Equipment Systems Co., Ltd.
8	I/O connector	TAE20R5-CN ⁽³⁾
9	Power cord	This must be prepared by customer.
10	Higher-level device	
11	I/O connector connection cable	

Notes ⁽¹⁾ For specific cord length, please contact IKO.
⁽²⁾ The lengths of the sensor extension cord is specified in the fields of □□ located at the end of the identification number with a length from 3 to 10m in units of 1m.
⁽³⁾ I/O connector TAE20R5-CN is a combined product of 10150-3000PE (connector) and 10350-52F0-008 (cover) from 3M Japan Limited.

● Setup software

To operate Alignment Stage SA, initial setting of driver parameters is required. Parameter setting for driver is performed using the setup software. It can also be used for gain adjustment and operational status check. In the driver, the setup software and PC connection cable are not provided. These can be shared in plural drivers but at least 1 set is required. Please prepare these on your own or place an order separately according to your requirement.

Table 8 System configuration for SA65DE, SA120DE with driver ADVA...EC

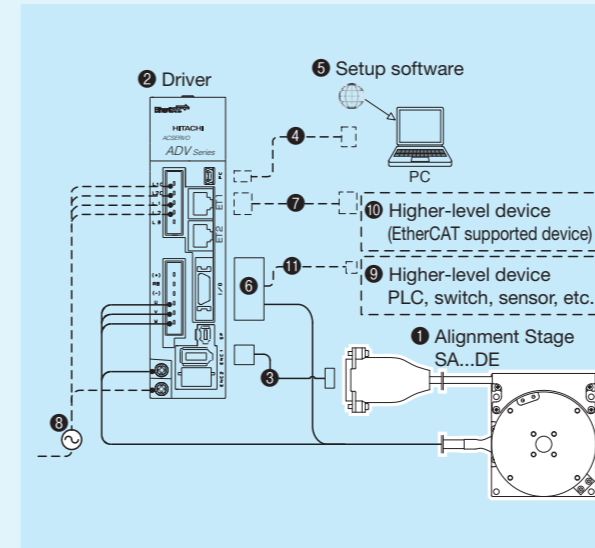

No.	Name	Identification Number
3	Encoder extension cord (2m) ⁽¹⁾	TAE20V4-EC02
4	PC connection cable	USB mini B cable This must be prepared by customer.
5	Setup software	ProDriveNext Please download from the official website of Hitachi Industrial Equipment Systems Co., Ltd.
6	I/O connector	TAE20V5-CN ⁽²⁾
7	Ethernet cable	This must be prepared by customer.
8	Power cord	
9	Higher-level device	
10	Higher-level device (EtherCAT supported device)	
11	I/O connector connection cable	

Notes ⁽¹⁾ For specific cord length, please contact IKO.
⁽²⁾ I/O connector TAE20V5-CN is a combined product of 10120-3000PE (connector) and 10320-52F0-008 (cover) from 3M Japan Limited.

Table 9 System configuration for SA200DE with driver ADVA...EC

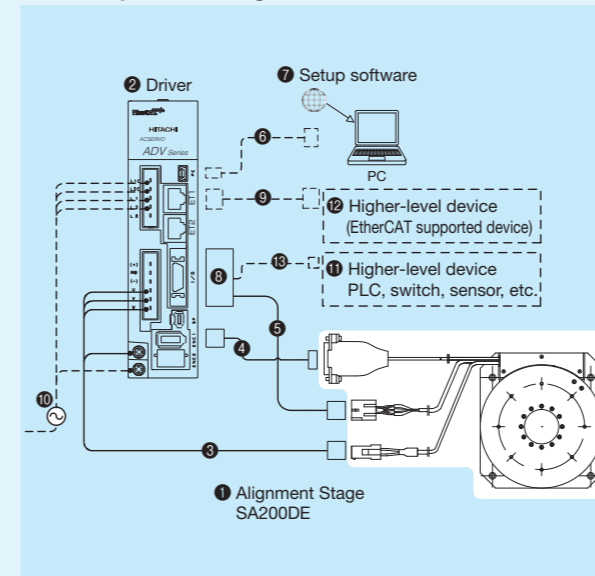

No.	Name	Identification Number
3	Motor extension cord (3m) ⁽¹⁾	TAE20V3-AM03
4	Encoder extension cord (2m) ⁽¹⁾	TAE20V4-EC02
5	Sensor extension cord ⁽²⁾	TAE10V8-LC□□
6	PC connection cable	USB mini B cable This must be prepared by customer.
7	Setup software	ProDriveNext Please download from the official website of Hitachi Industrial Equipment Systems Co., Ltd.
8	I/O connector	TAE20V5-CN ⁽³⁾
9	Ethernet cable	This must be prepared by customer.
10	Power cord	
11	Higher-level device	
12	Higher-level device (EtherCAT supported device)	
13	I/O connector connection cable	

Notes ⁽¹⁾ For specific cord length, please contact IKO.
⁽²⁾ The lengths of the sensor extension cord is specified in the fields of □□ located at the end of the identification number with a length from 3 to 10m in units of 1m.
⁽³⁾ I/O connector TAE20V5-CN is a combined product of 10120-3000PE (connector) and 10320-52F0-008 (cover) from 3M Japan Limited.

Table 10 System configuration (SSCNET III/H supported) for SA65DE, SA120DE with driver MR-J4-10B

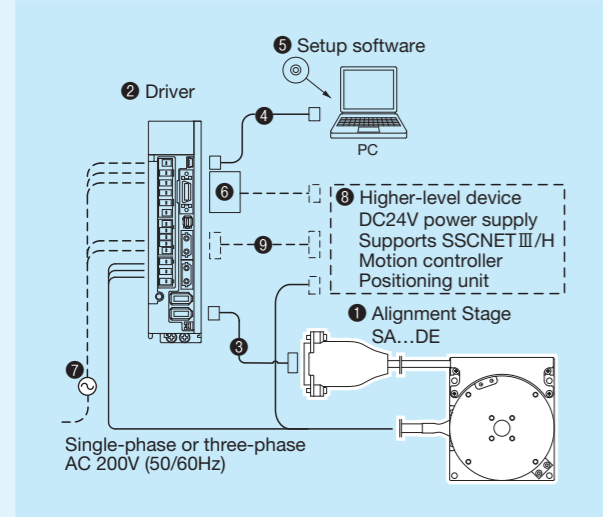

No.	Name	Identification Number
3	Encoder extension cord (2m) ⁽¹⁾	TAE20V6-EC02
4	PC connection cable (3m)	MR-J3USBCBL3M
5	Setup software	SW1DNC-MRC2-J
6	Connectors for input/output connection	MR-CCN1 ⁽²⁾
7	Power cord	This must be prepared by customer.
8	Higher-level device ⁽³⁾	
9	Connection cable for SSCNET III/H	

Notes ⁽¹⁾ For specific cord length, please contact IKO.
⁽²⁾ Connector for input/output connection MR-CCN1 is a combined product of 10120-3000PE (connector) and 10320-52F0-008 (cover) from 3M Japan Limited.
⁽³⁾ The higher-level devices are a motion controller, positioning unit and DC24V power supply ready for SSCNET III/H from Mitsubishi Electric Corporation.

Table 11 System configuration (SSCNET III/H supported) for SA200DE with driver MR-J4-10B

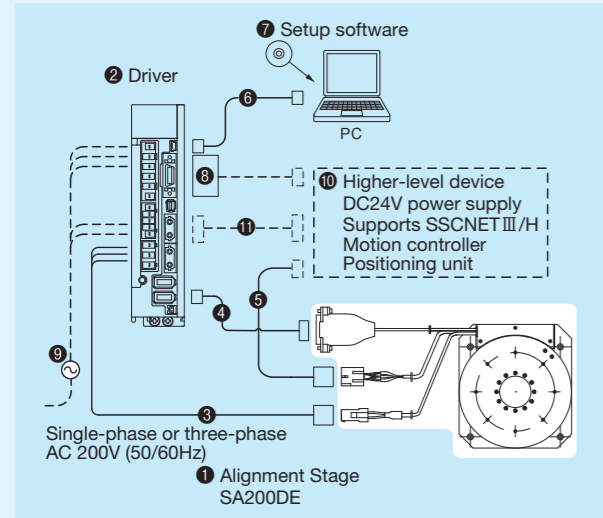

No.	Name	Identification Number
3	Motor extension cord (3m) ⁽¹⁾	TAE20V3-AM03
4	Encoder extension cord (2m) ⁽¹⁾	TAE20V6-EC02
5	Sensor extension cord ⁽²⁾	TAE10V8-LC□□
6	PC connection cable (3m)	MR-J3USBCBL3M
7	Setup software	SW1DNC-MRC2-J
8	Connectors for input/output connection	MR-CCN1 ⁽³⁾
9	Power cord	This must be prepared by customer.
10	Higher-level device ⁽⁴⁾	
11	Connection cable for SSCNET III/H	

Notes ⁽¹⁾ For specific cord length, please contact IKO.
⁽²⁾ The lengths of the sensor extension cord is specified in the fields of □□ located at the end of the identification number with a length from 3 to 10m in units of 1m.
⁽³⁾ Connector for input/output connection MR-CCN1 is a combined product of 10120-3000PE (connector) and 10320-52F0-008 (cover) from 3M Japan Limited.
⁽⁴⁾ The higher-level devices are a motion controller, positioning unit and DC24V power supply ready for SSCNET III/H from Mitsubishi Electric Corporation.

IKO Alignment Stage SA

SA65DE/X

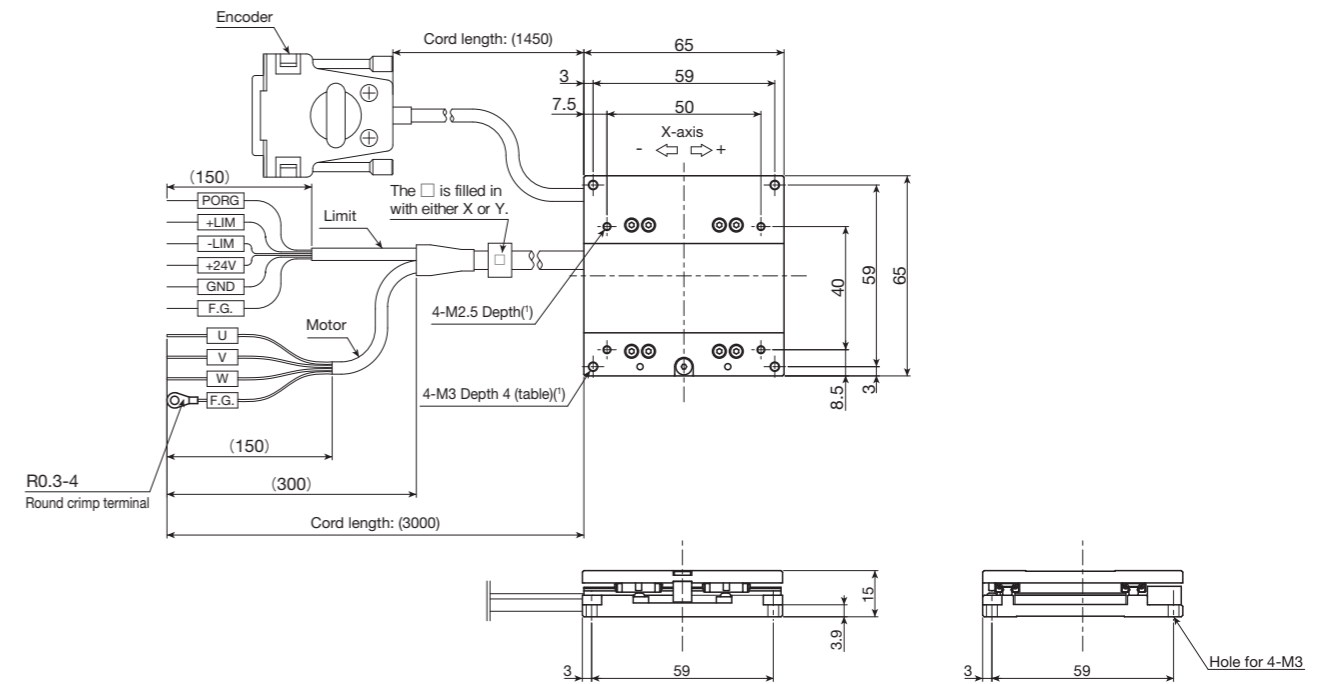

SA65DE/S

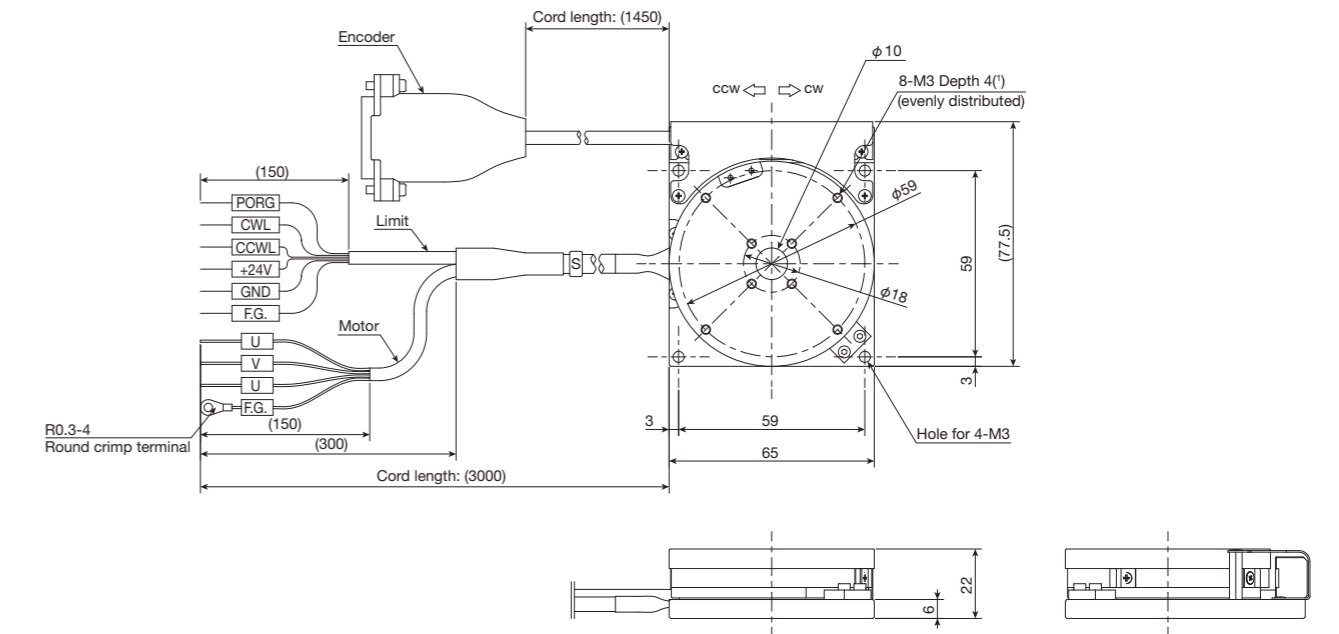

Note ⁽¹⁾ Too deep insertion depth of the mounting bolt may affect the running performance of the moving table, so never insert a bolt longer than the depth of the through hole.
 Remark: The text direction of the mark tube of the motor / limit cord may vary by product.
 The central hole of the θ -table is a through hole.

IKO Alignment Stage SA

SA65DE/XY

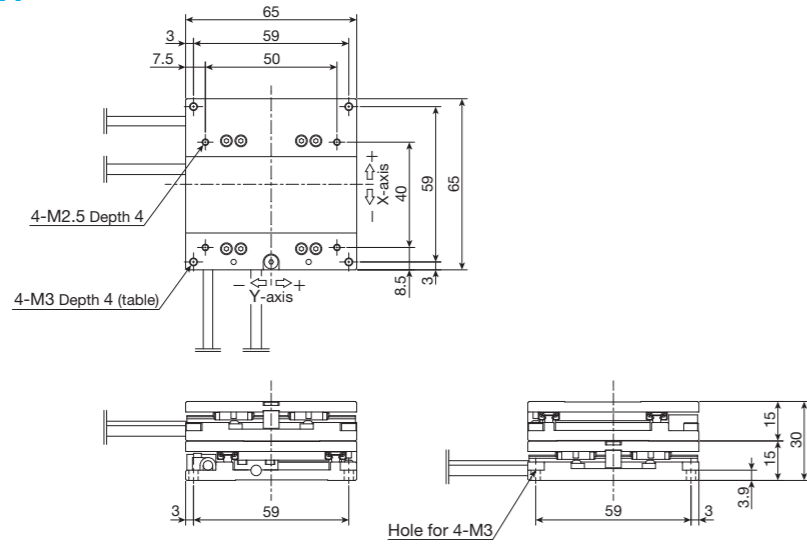

SA65DE/XS

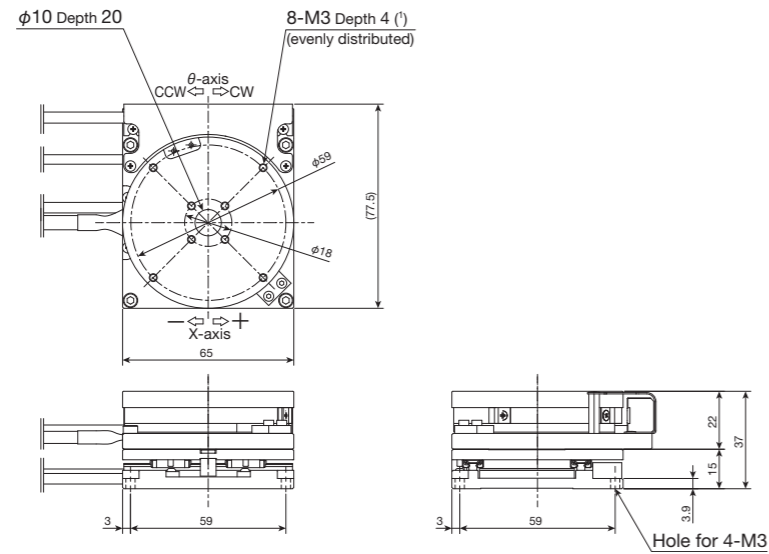

SA65DE/XYS

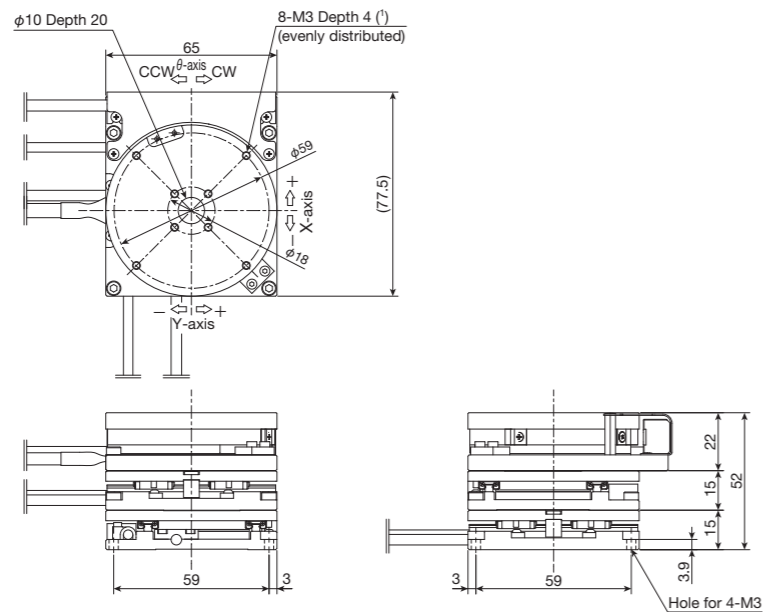

Note (1) Too deep insertion depth of the mounting bolt may affect the running performance of the moving table, so never insert a bolt longer than the depth of the through hole.
Remark: For the cable length, please see the dimension tables for SA65DE/X and SA65DE/S.

SA120DE/X

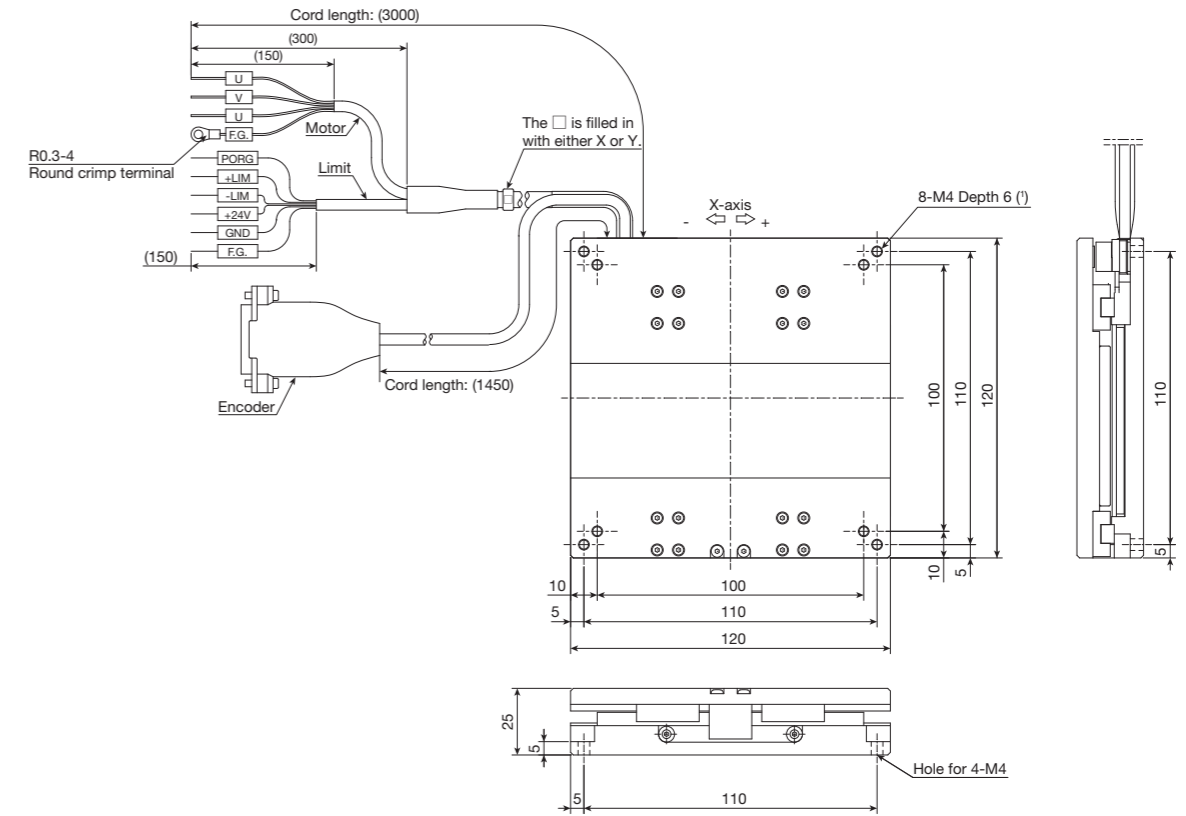

SA120DE/S

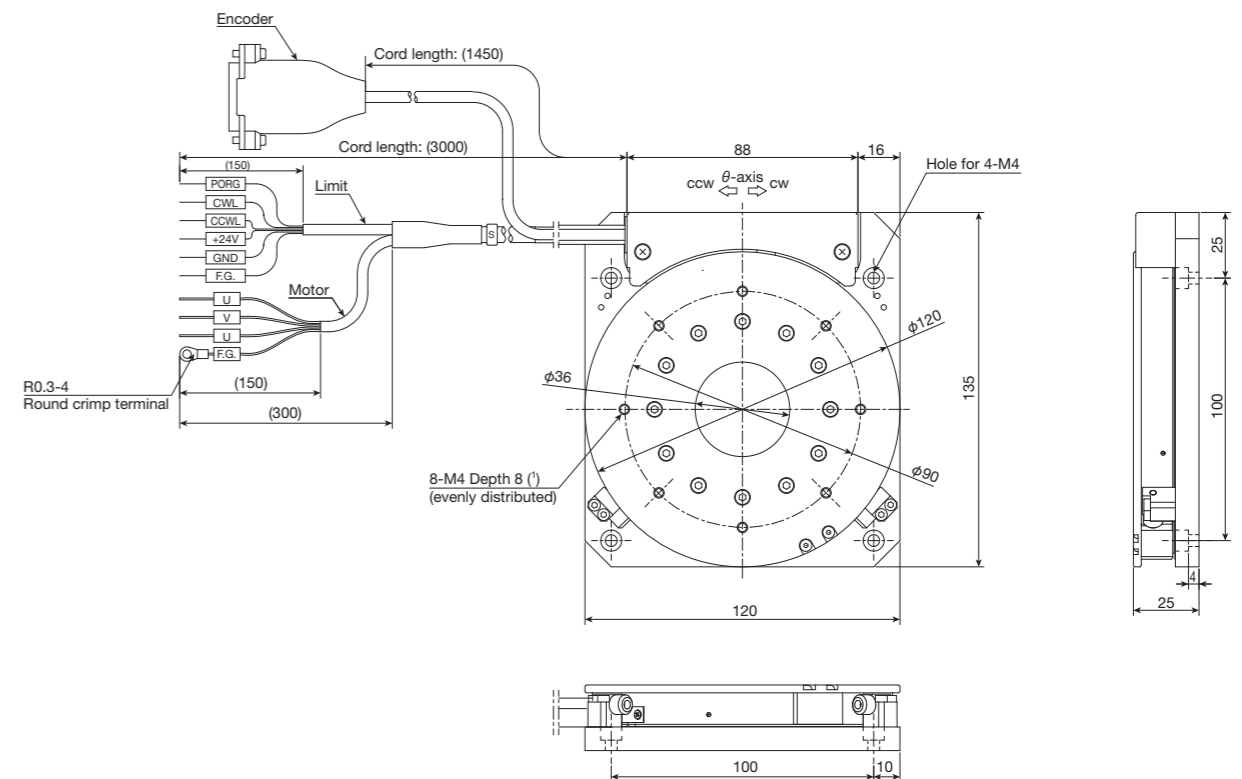

Note (1) Too deep insertion depth of the mounting bolt may affect the running performance of the moving table, so never insert a bolt longer than the depth of the through hole.
Remark: The text direction on the mark tube of the motor / limit cord may vary by product.
The central hole of the θ -table is a through hole.

IKO Alignment Stage SA

SA120DE/XY

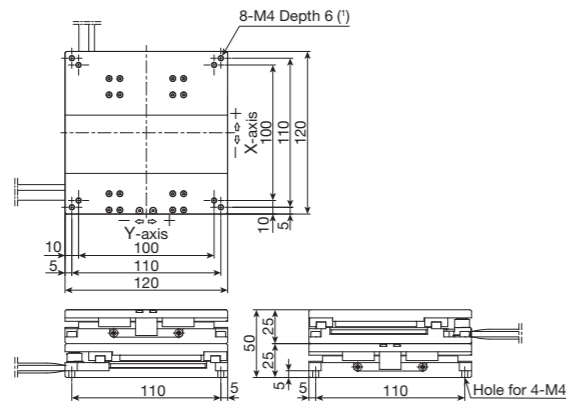

SA120DE/XS

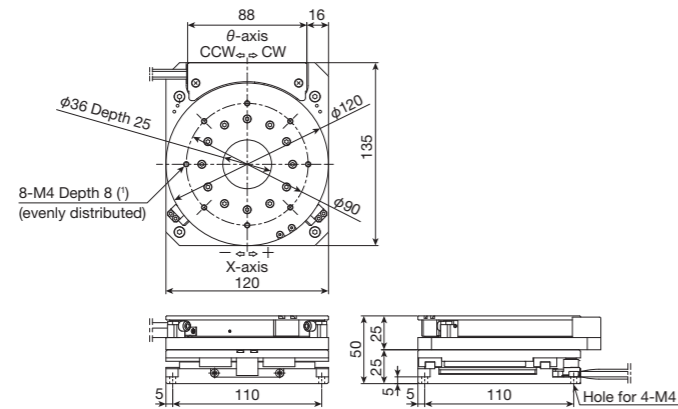

SA120DE/XYS

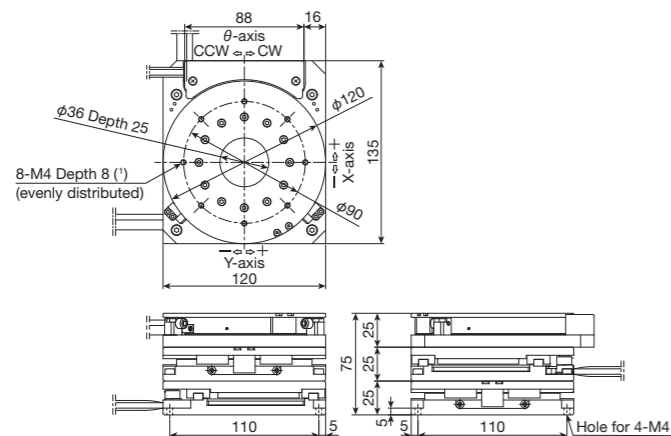

Note (1) Too deep insertion depth of the mounting bolt may affect the running performance of the moving table, so never insert a bolt longer than the depth of the through hole.
Remark: For the cable length, please see the dimension tables for SA120DE/X and SA120DE/S.

SA200DE/X

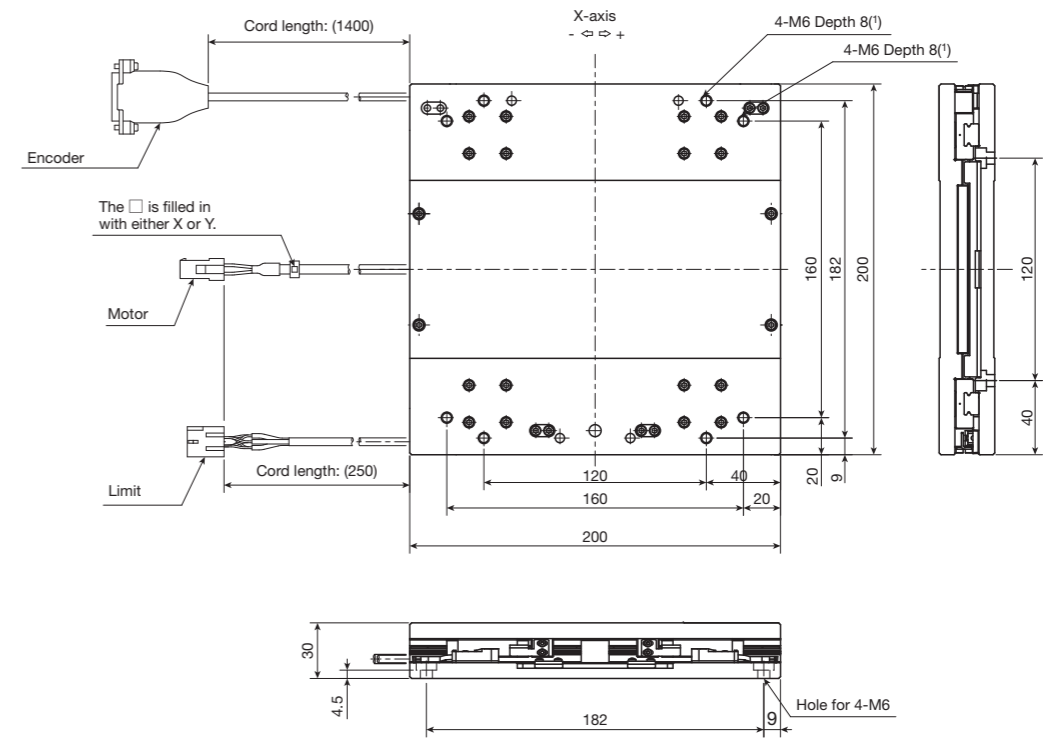

SA200DE/S

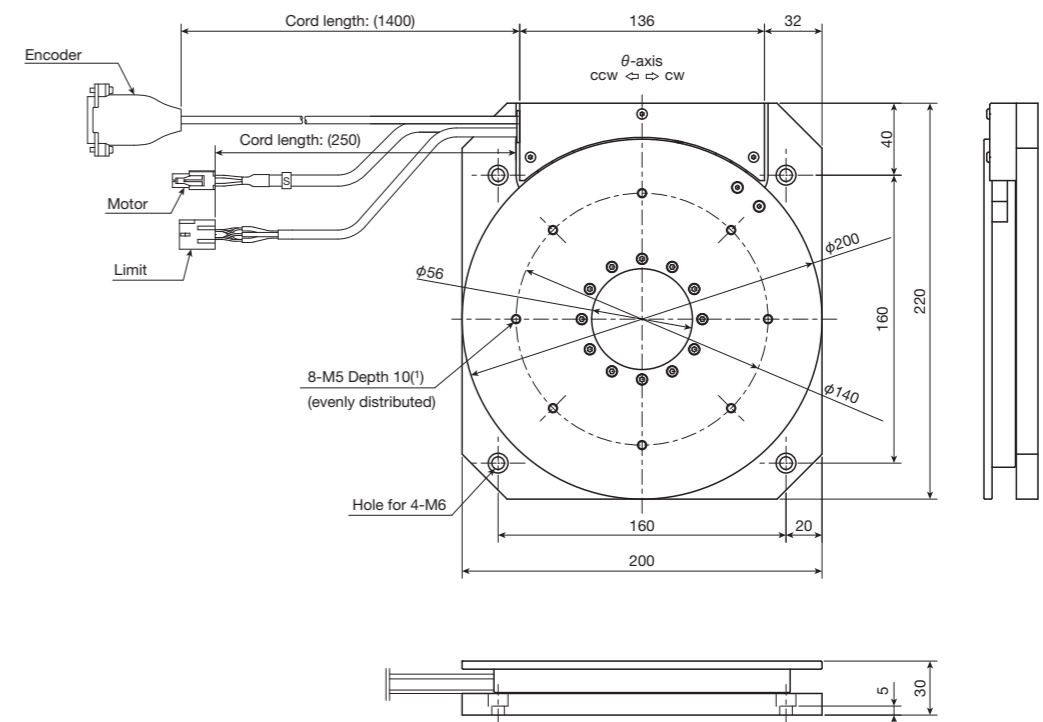

Note (1) Too deep insertion depth of the mounting bolt may affect the running performance of the moving table, so never insert a bolt longer than the depth of the through hole.
Remark: The central hole of the θ -table is a through hole.

IKO Alignment Stage SA

SA200DE/XY

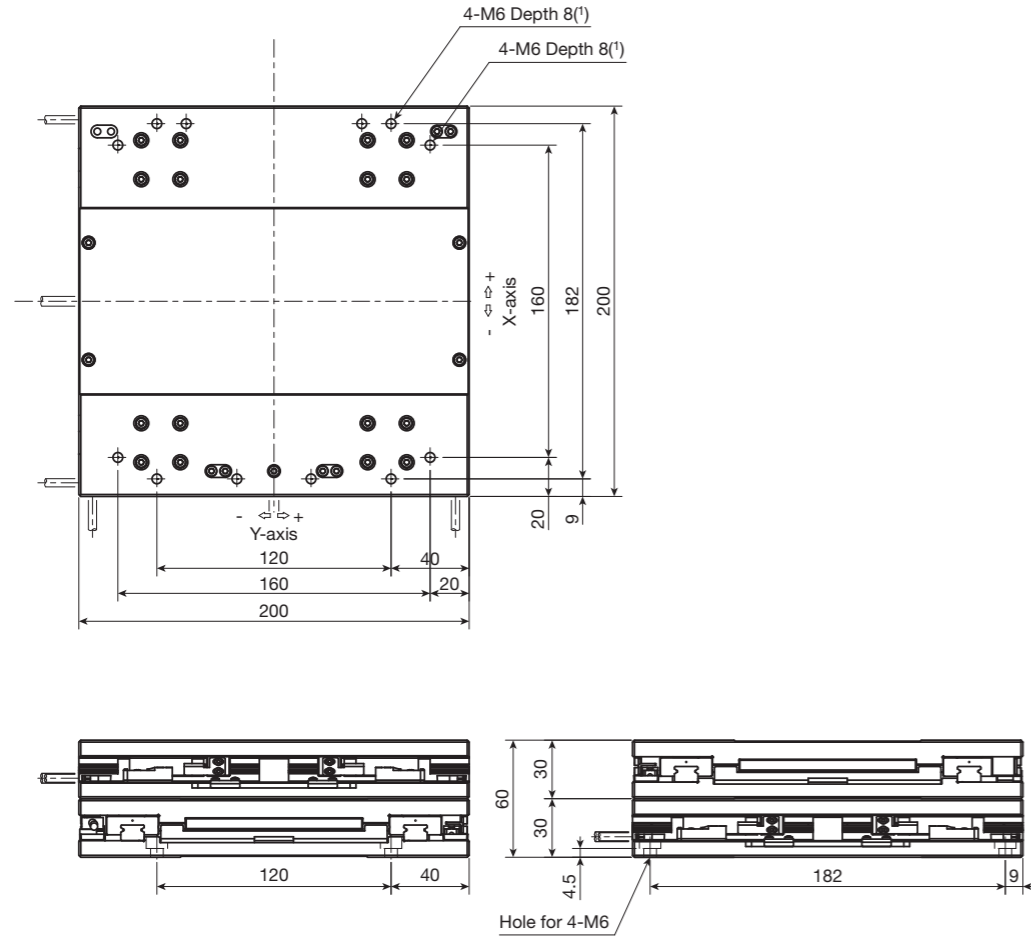

SA200DE/XS

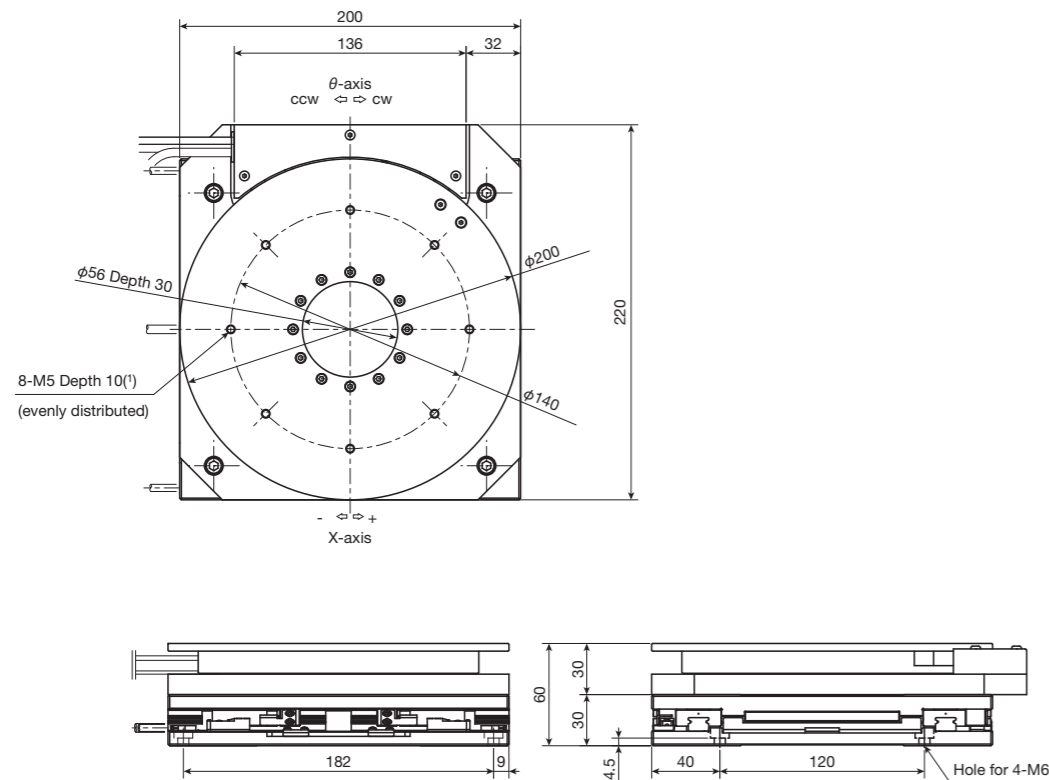

Note (1) Too deep insertion depth of the mounting bolt may affect the running performance of the moving table, so never insert a bolt longer than the depth of the through hole.

Remark: For the cable length, please see the dimension tables for SA200DE/X and SA200DE/S.

SA200DE/YS

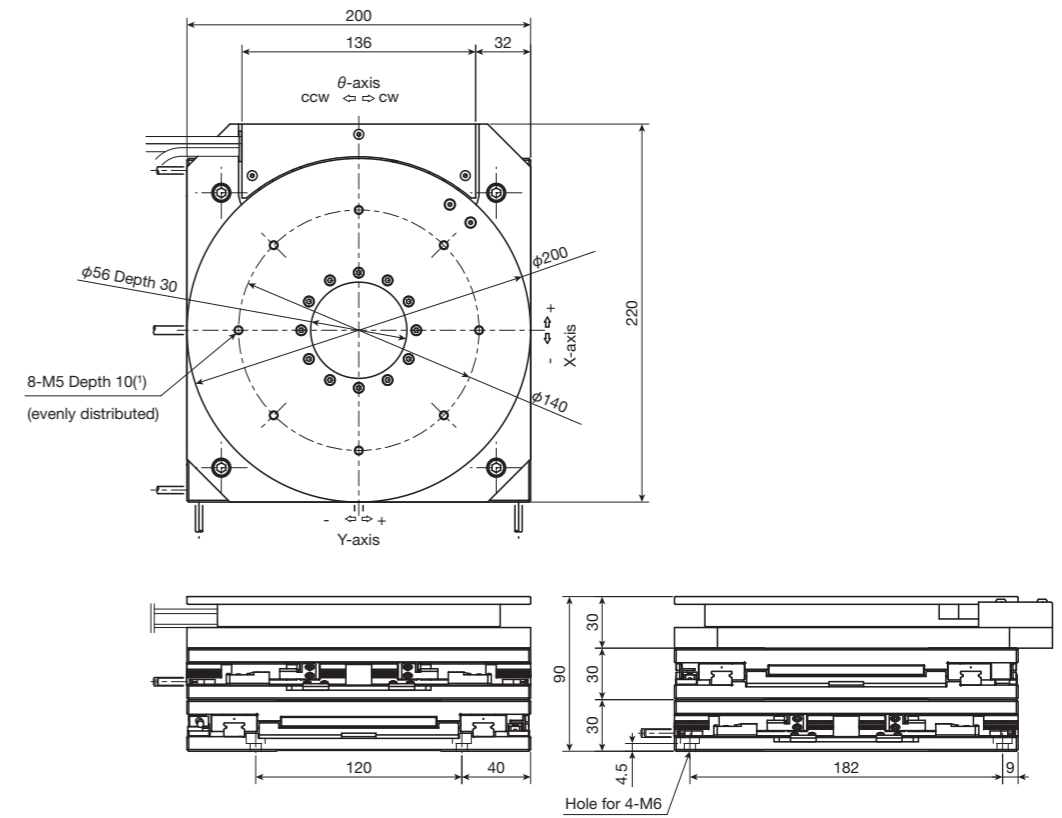

Note (1) Too deep insertion depth of the mounting bolt may affect the running performance of the moving table, so never insert a bolt longer than the depth of the through hole.

Remark: For the cable length, please see the dimension tables for SA200DE/X and SA200DE/S.