



BEARINGS



Recognizing that conservation of the global environment is the top-priority challenge for the world's population, Nippon Thompson will conduct its activities with consideration of the environment as a corporate social responsibility, reduce its negative impact on the environment, and help foster a rich global environment.

ISO 9001 & 14001 Quality system registration certificate



- The specifications and dimensions of products in this catalog are subject to change without prior notice.
- When these products are exported, the exporter should confirm a forwarding country and a use, and, in case of falling under the customer's requirements, take necessary procedures such as export permission application.
- Although all data in this catalog has been carefully compiled to make the information as complete as possible, NIPPON THOMPSON CO., LTD. shall not be liable for any damages whatsoever, direct or indirect, based upon any information in this catalog. NIPPON THOMPSON CO., LTD. makes no warranty, either express or implied, including the implied warranty of merchantability or fitness for a particular purpose.
- Reproduction and conversion without permission are prohibited.

IKO INDEX OF DIMENSION TABLES

General Explanation



TA...Z TAM — B7
TLA...Z TLAM — B7
YT YTL — B7

BA...Z BAM — B27
BHA...Z BHAM — B27
YB YBH — B27

Shell Type Needle Roller Bearings



KT — C5
KT...EG — C21
KTV...EG — C22

Needle Roller Cages
for general usage
Needle Roller Cages
for engine connecting rods



(R) NA 49 — (D7)D29
(R) NA 48 — (D23)D41
TAF (I) — D7(D29)

TR (I) — D9(D31)
BR (I) — D47(D51)
TAF.../SG — D77



(R) NA 69 — D9(D29)



GTR (I) — D9(D31)



(R) NAF — (D83)D89

Machined Type Needle Roller Bearings
Needle Roller Bearings
with separable cage



NAG 49 — E7
NAU 49 — E7
TRU — E7



NAS 50 — E19

Roller Bearings



NTB AS — F7
WS GS — F7



AZK — F11
WS GS — F11

Thrust Bearings



NAX (I) — G5(G7)
NBX (I) — G5(G7)



NATA 59 — G9
NATB 59 — G9

Combined Type Needle Roller Bearings



IRT — H5
IRB — H10
LRT — H13

LRTZ — H13
LRB — H25
LRBZ — H25

Inner Rings



CL — I22
CF...B — I25
CFKR — I31
CFE...B — I35
CFKRE — I39

CFES...B — I43
CF...WB — I45
CF-RU1 — I49
CF-FU1 — I49
CF-SFU...B — I51

CF...G — I53
CF.../SG — I55
CFC...B — I57
CFS — I59
CFS...W — I63

NUCF...B — I67
CR — I69
CR...B — I69
CRH...B — I79



(R)NAST — (I91)I92
NART — I95
NART.../SG — I101

NURT — I103
CRY — I105

Cam Followers
Roller Followers



CRBHV — J15



CRBFV — J17



CRBC — J19
CRB — J19



CRBT — J23



CRBTF — J25



CRBS — J27

Crossed Roller Bearings



SB — K11
GE — K15
SBB — K23



PB — K37



PHS — K38
POS — K39
PHSA — K42



LHSA — K49
LHS — K51



SNA — K58
SNM — K59
SNPT — K59

Spherical Bushings
Pillballs L-balls
Super Flexible Nozzles



OS — L3
DS — L4



WR — L19
AR — L21



Needle Roller — L25

Parts For Needle Roller Bearings

Miscellaneous Tables — M33

Presentation of Mechatronics Series — M57

Miscellaneous Tables
Presentation of Linear Motion Rolling Guide
and Mechatronics Series

A

B

C

D

E

F

G

H

I

J

K

L

M



Gifu factory main entrance



Assembling process in a clean room



The IKO Needle Roller Bearing Series are manufactured through a control system that alleviates their impact on the global environment to meet the quality requirements of ISO 14001 in compliance with the quality requirements level of ISO 9001 for quality improvement. The standard products listed in this catalog comply with the specifications of the ten hazardous materials mentioned cited in the European RoHS Directive.

In the table of dimensions, standard products are referred to using identification numbers marked with . The products are reputed for high quality, reasonable price and quick delivery. The identification numbers marked with refer to our semi-standard products. The specifications and dimensions of products in this catalogue are subject to change without prior notice.

Index

General Explanation

Characteristics of Needle Roller Bearings	A 3
Types and Features of Bearings	A 5
Outline of Bearing Selection	A 16
Basic Dynamic Load Rating and Life	A 17
Basic Static Load Rating and Static Safety Factor	A 21
Calculation of Bearing Loads	A 22
Boundary Dimensions and Identification Number	A 26
Accuracy	A 30
Clearance	A 37
Fit	A 39
Design of Shaft and Housing	A 44
Lubrication	A 49
Friction and Allowable Rotational Speed	A 56
Operating Temperature Range	A 57
Handling of Bearings	A 57

Description of Each Series & Table of Dimensions

Shell Type Needle Roller Bearings	TA·TLA·BA·BHA	B 1
Needle Roller Cages for general usage	KT·KT··N	C 1
Needle Roller Cages for engine connecting rods	KT··EG·KTV··EG	C 17
Machined Type Needle Roller Bearings	NA·TAFI·TRI·BRI	D 1
C-Lube Machined Type Needle Roller Bearings	TAF··/SG	D 75
Needle Roller Bearings with separable cage	NAF	D 79
Roller Bearings	NAG·NAU·TRU·NAS	E 1
Thrust Bearings	NTB·AS·AZK·WS·GS	F 1
Combined Type Needle Roller Bearings	NAX·NBX·NATA·NATB	G 1
Inner Rings	IRT·IRB·LRT·LRB	H 1
Cam Followers	CF··B·CFKR·CFS·NUCF··B·CR··B·CR	I 1
C-Lube Cam Followers	CF··/SG	I 55
Short Stud Type Cam Followers	CFC··B	I 57
Roller Followers	NAST·NART·NURT·CRY	I 83
C-Lube Roller Followers	NART··/SG	I 101
Crossed Roller Bearings	CRBHV·CRBFV·CRBC·CRB·CRBT·CRBTf·CRBS	J 1
Spherical Bushings	SB·GE·SBB	K 1
Pilloballs	PB·PHS·POS·PHSA	K 29
L-balls	LHSA·LHS	K 45
Super Flexible Nozzles	SNA·SNM·SNPT	K 55
Parts For Needle Roller Bearings	OS·DS·WR·AR·Needle Roller	L 1

Miscellaneous Tables

M33

Alphabetical Index

M59

General Explanation



Nippon Thompson Co., Ltd. is a bearing manufacturer that launched the technical development of needle roller bearings for the first time in Japan and is proud of the high quality level and abundant varieties of its products.

Needle roller bearings are bearings for rotary motion that incorporate needle-shaped thin rollers instead of ordinary bearing balls or rollers. Compared with other rolling bearings, they are small-sized and lightweight but have a large load capacity. They are widely used with high reliability in the fields of automobiles, industrial machinery, OA equipment, etc. as resource-saving type bearings that make the whole machine compact.

Characteristics of Needle Roller Bearings

Bearings can be classified into two main types, namely rolling bearings and sliding bearings. Rolling bearings can be subdivided further into ball bearings and roller bearings according to the rolling elements. IKO Needle Roller Bearings are high-precision rolling bearings with a low sectional height, incorporating needle rollers as the rolling element. They have the following features.

Merits of Rolling Bearings

Compared with sliding bearings, rolling bearings have the following merits:

1 Static and kinetic friction is low.

Since the difference between static friction and kinetic friction is small and the frictional coefficient is also small, drive units or machines can be made more compact and lightweight, saving machine costs and power consumption.

2 Stable accuracy can be maintained for long periods.

Owing to less wear, stable accuracy can be maintained for long periods.

3 Machine reliability is improved.

Since the bearing life can be estimated based on rolling fatigue, machine reliability is improved.

4 Lubrication is simplified.

Since grease lubrication is sufficient in most cases, lubrication can be simplified for easy maintenance.

Merits of Needle Roller Bearings

Compared with other rolling bearings, IKO Needle Roller Bearings have the following advantages:

1 With a low sectional height, they can withstand heavy loads.

Since they have a low sectional height compared with other rolling bearings and yet can withstand heavy loads, machines can be made more compact and lightweight, thus saving costs.

2 Rotating torque is small, improving mechanical efficiency.

Since the rotating radius is small, the rotating torque is also small under the same frictional conditions, thus improving mechanical efficiency.

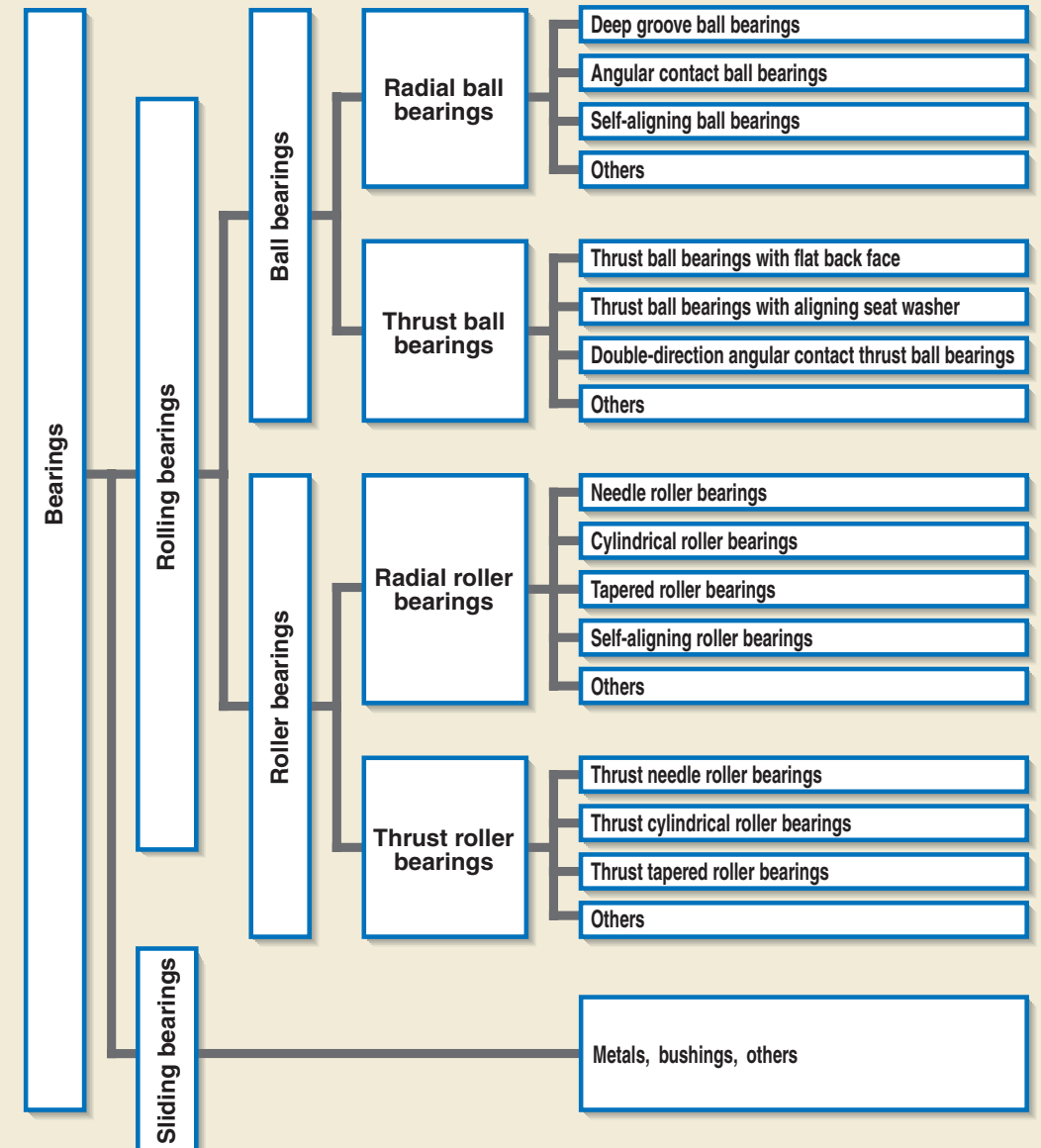
3 Inertia is minimized.

Since the bearing volume and weight are small, the moment of inertia of the bearing is minimized when it is put in motion.

4 Most suited to oscillating motions.

Many rolling elements are arranged at a small spacing pitch, and this configuration is most suited to oscillating motions.

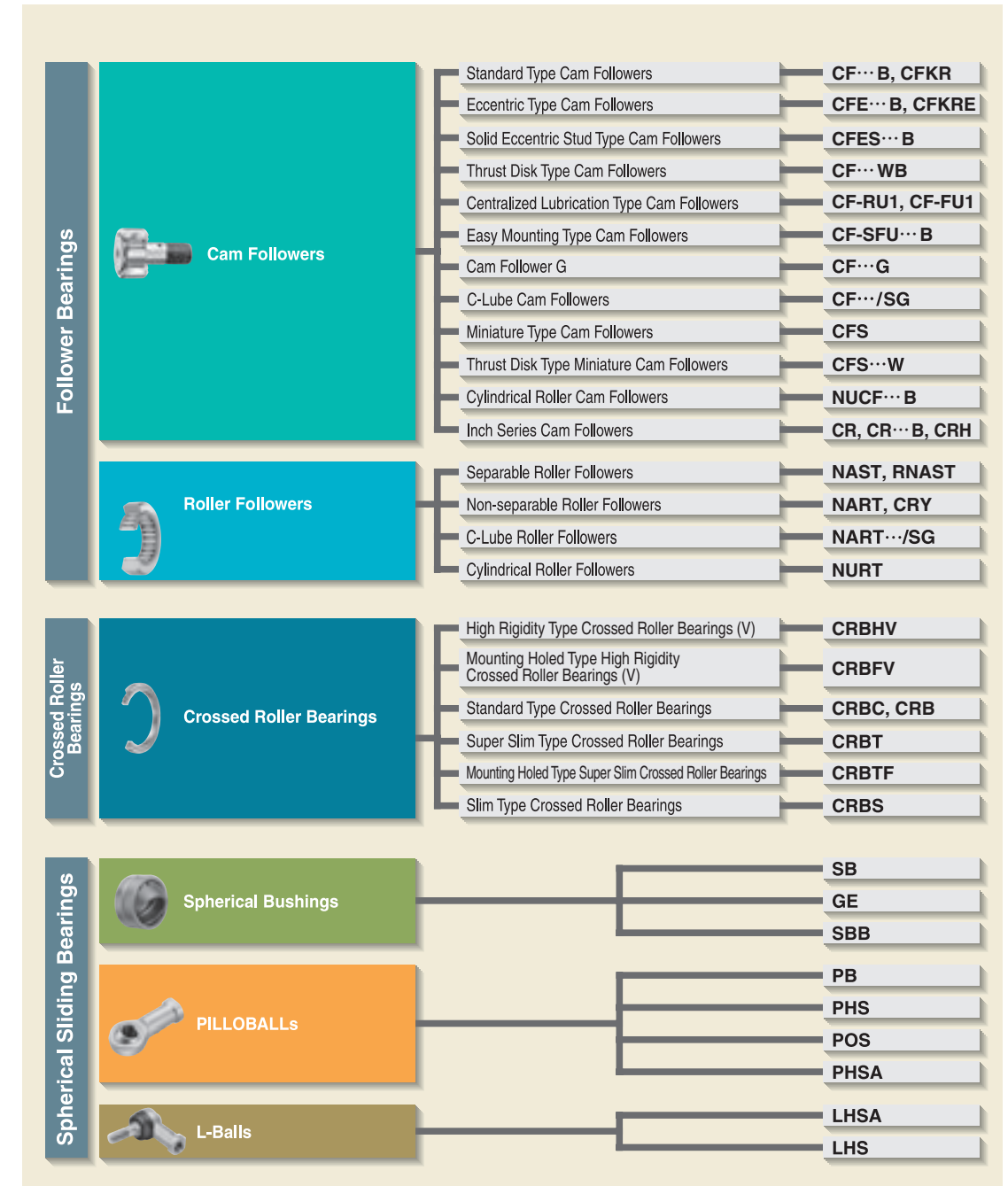
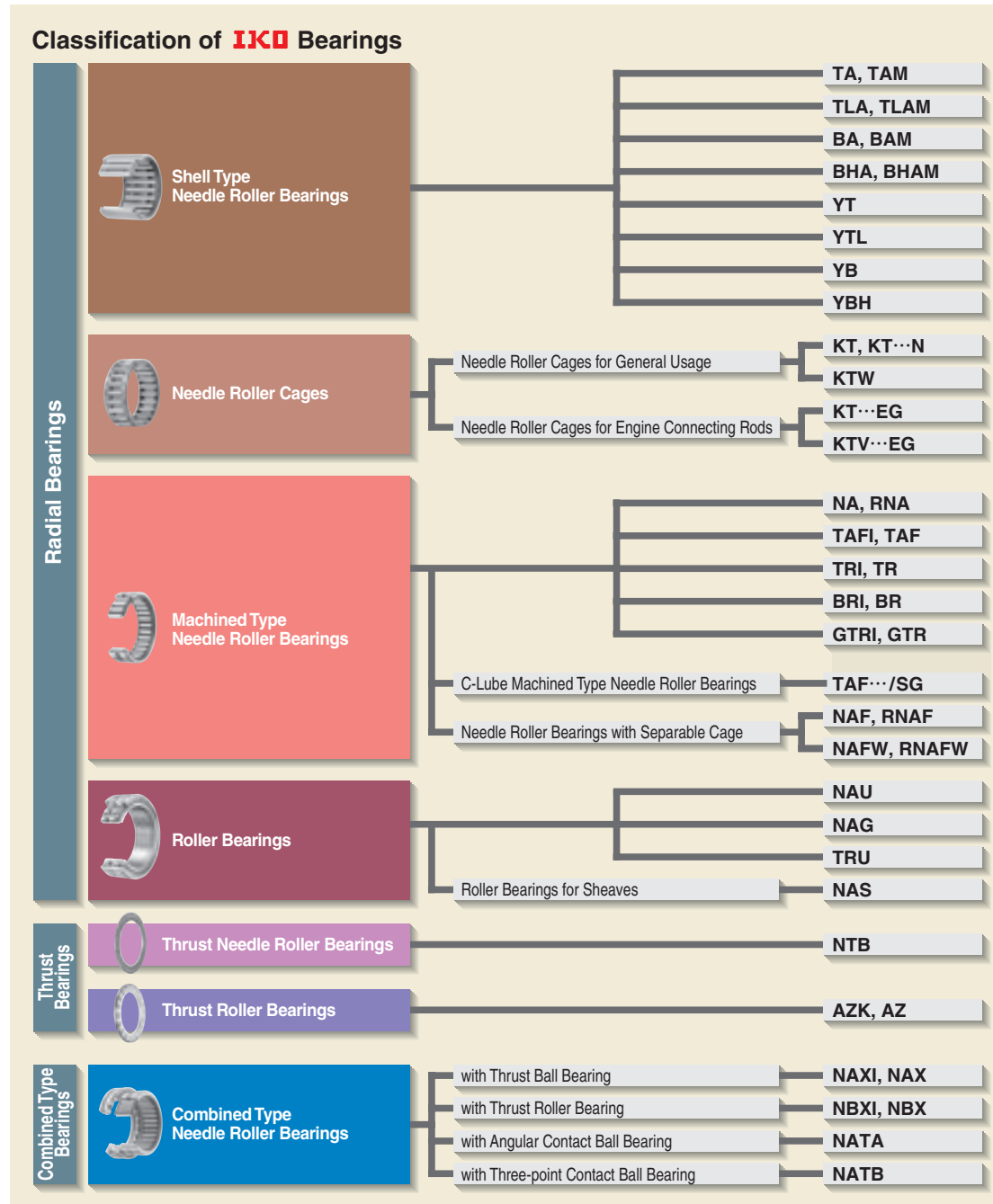
Classification of bearings



Types and Features of Bearings

IKO Bearings can be roughly classified into radial bearings and thrust bearings according to applicable load direction. Radial Bearings are grouped into Shell Type Needle Roller Bearings, Machined Type Needle Roller Bearings, and various other types. Thrust Bearings are grouped into Thrust Needle Roller Bearings and Thrust Roller Bearings. Follower Bearings that are used for cam mechanisms and linear motion are grouped into Cam Followers and Roller Followers.

Crossed Roller Bearings are special shape bearings that can simultaneously receive loads in all directions with a single bearing. Bearings other than rolling bearings, such as self-aligning Spherical Bushings that can support radial loads and axial loads and PILLOBALLs and L-Balls that are used for link mechanisms, are also available.



Shell Type Needle Roller Bearings



Shell Type Needle Roller Bearings are lightweight with the lowest sectional height among needle roller bearings with outer ring, because they employ a shell type outer ring made from a thin special-steel plate which is accurately drawn, carburized and quenched. Since these bearings are press-fitted into the housing, no axial positioning fixtures are required. They are ideal for use in mass-produced articles that require economy.

Radial Bearings Page B1

Machined Type Needle Roller Bearings



Machined Type Needle Roller Bearings have an outer ring made by machining, heat treatment, and grinding. The outer ring has stable high rigidity and can be easily used even for light alloy housings. These bearings are available in various types and optimally selectable for different conditions such as heavy loads, high-speed rotation and low-speed rotation. They are most suitable for general-purpose applications.

Radial Bearing Page D1

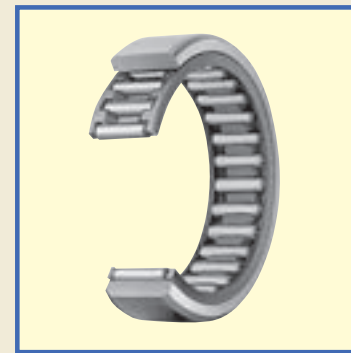
Needle Roller Cages for General Usage



Needle Roller Cages for General Usage are bearings that display excellent rotational performance. Their specially shaped cages with high rigidity and accuracy, precisely guide the needle rollers. Since needle rollers with extremely small dimensional variations in diameter are incorporated and retained, Needle Roller Cages for General Usage are useful in small spaces when combined with shafts and housing bores that are heat treated and accurately ground as raceway surfaces.

Radial Bearing Page C1

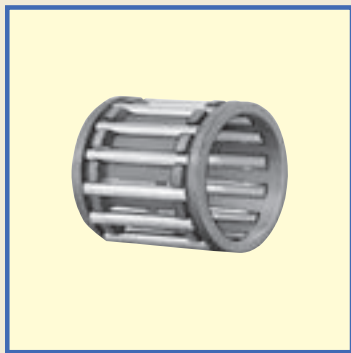
Needle Roller Bearings with Separable Cage



In Needle Roller Bearings with Separable Cage, the inner ring, outer ring and Needle Roller Cage are combined, and they can be separated easily. This type has a simple structure with high accuracy. In addition, the radial clearance can be freely selected by choosing an assembly combination. These bearings have excellent rotational performance, because Needle Roller Cages are used.

Radial Bearing Page D79

Needle Roller Cages for Engine Connecting Rods



Needle Roller Cages for Engine Connecting Rods are used for motor cycles, small motor vehicles, outboard marines, snow mobiles, general-purpose engines, high-speed compressors, etc. that are operated under extremely severe and complex operating conditions such as heavy shock loads, high speeds, high temperatures, and stringent lubrication. Needle Roller Cages for Engine Connecting Rods are lightweight and have high load ratings and high rigidity as well as superior wear resistance.

Radial Bearing Page C17

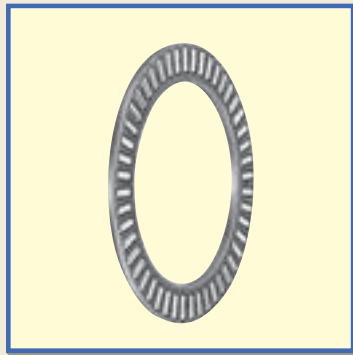
Roller Bearings



Roller Bearings, in which rollers are incorporated in double rows, are non-separable heavy-duty bearings. They can withstand not only radial loads but axial loads as well, which are supported at the contacts between the shoulders of inner and outer rings and the end faces of rollers. Therefore, they are most suitable for use at the fixing side of a shaft.

Radial Bearing Page E1

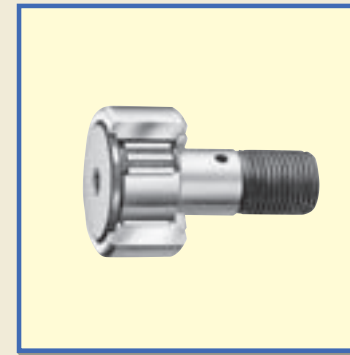
Thrust Bearings



Thrust Bearings consist of a precisely made cage and rollers, and can receive axial loads. They have high rigidity and high load capacities and can be used in small spaces. Thrust Needle Roller Bearings use needle rollers, while Thrust Roller Bearings use cylindrical rollers.

Thrust Bearing Page F1

Cam Followers



Cam Followers are bearings with a stud incorporating needle rollers in a thick walled outer ring. They are designed for outer ring rotation, and the outer rings run directly on mating cam guide surfaces. Various types of Cam Followers are available. They are widely used as follower bearings for cam mechanisms and for linear motions.

Follower Bearing Page I1

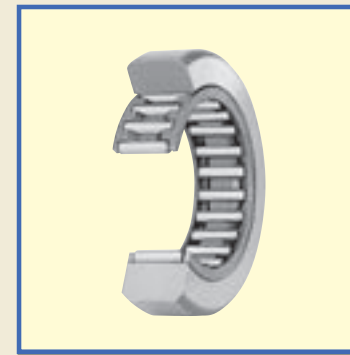
Combined Type Needle Roller Bearings



Combined Type Needle Roller Bearings are combinations of a radial bearing and a thrust bearing. Caged Needle Roller Bearings are used as radial bearings and Thrust Ball Bearings or Thrust Roller Bearings are used as thrust bearings. They can be subjected to radial loads and axial loads simultaneously.

Combined Type Bearing Page G1

Roller Followers



Roller Followers are bearings in which needle rollers are incorporated in a thick walled outer ring. These bearings are designed for outer ring rotation, and the outer rings run directly on mating cam guide surfaces. They are used as follower bearings for cam mechanisms and for linear motions.

Follower Bearing Page I83

Inner Rings



Inner Rings are heat-treated and finished by grinding to a high degree of accuracy and are used for Needle Roller Bearings. In the case of Needle Roller Bearings, normally the shafts are heat-treated and finished by grinding and used as raceway surfaces. However, when it is impossible to make shaft surfaces according to the specified surface hardness or surface roughness, Inner Rings are used.

Component part Page H1

Crossed Roller Bearings



Crossed Roller Bearings are high-rigidity and compact bearings with their cylindrical rollers alternately crossed at right angles to each other between inner and outer rings. A single Crossed Roller Bearing can take loads from any directions at the same time such as radial, thrust, and moment loads. These bearings are widely used in the rotating parts of industrial robots, machine tools, medical equipment, etc. which require compactness, high rigidity and high rotational accuracy.

Crossed Roller Bearing Page J1

Spherical Bushings



Spherical Bushings are self-aligning spherical plain bushings, which have inner and outer rings with spherical sliding surfaces. They can take a large radial load and a bi-directional axial load at the same time. They are divided into steel-on-steel types that are suitable for applications where there are alternate loads or shock loads, and maintenance-free types which require no lubrication.

Spherical Sliding Bearing Page K1

PILLOBALLS



PILLOBALLS are compact self-aligning spherical plain bushings which can support a large radial load and a bi-directional axial load at the same time. PILLOBALL Rod Ends have either a female thread in the body or a male thread on the body, so they can be easily assembled onto machines. PILLOBALLS are used in control and link mechanisms in machine tools, textile machines, packaging machines, etc.

Spherical Sliding Bearing Page K29

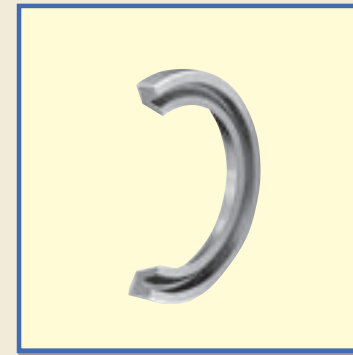
L-Balls



L-Balls are self-aligning rod-ends consisting of a special zinc die-cast alloy body and a studded ball which has its axis at right-angles to the body. They can perform tilting movement and rotation with low torque, and transmit power smoothly due to the uniform clearance between the sliding surfaces. They are used in link mechanisms in automobiles, construction machinery, farm and packaging machines, etc.

Spherical Sliding Bearing Page K45

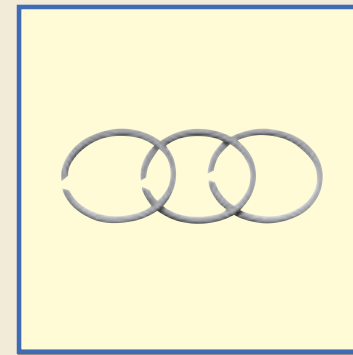
Seals for Needle Roller Bearings



Seals for Needle Roller Bearings have a low sectional height and consist of a sheet metal ring and special synthetic rubber. As these seals are manufactured to the same sectional height as Needle Roller Bearings, grease leakage and the penetration of foreign particles can be effectively prevented by fitting them directly to the sides of combinable bearings.

Component Part Page L1

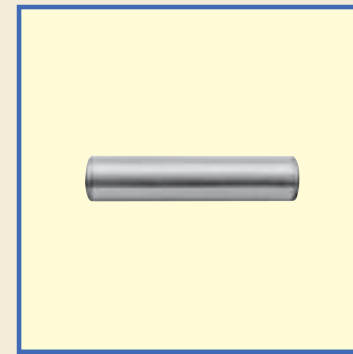
Cir-clips for Needle Roller Bearings



Cir-clips for Needle Roller Bearings have been specially designed for needle roller bearings on which, in many cases, generally available Cir-clips cannot be used. They have a low sectional height and are very rigid. There are Cir-clips for shafts and for bores, and they are used for positioning to prevent bearing movement in the axial direction.

Component Part Page L17

Needle Rollers



Needle Rollers are used for needle roller bearings and are rigid and highly accurate. These needle rollers are widely used as rolling elements for bearings, and also as pins and shafts.

Component Part Page L23

Features of IKO Bearings

Bearing series		Appearance	Direction of motion	Load direction and capacity	Allowable rotational speed	Friction	Sectional height	Reference page
Shell Type Needle Roller Bearings	Caged type							B1~
	Full complement type							
Needle Roller Cages	For general usage							C1~
	For engine connecting rods							C17~
Machined Type Needle Roller Bearings	Caged type							D1~
	Full complement type							
Needle Roller Bearings with Separable Cage	Caged type							D79~
Roller Bearings	Caged type							E1~
	Full complement type							
	For sheaves							

Symbol Rotation Oscillating motion Radial load Axial load Light load Medium load Heavy load Especially excellent Excellent Normal

Bearing series		Appearance	Direction of motion	Load direction and capacity	Allowable rotational speed	Friction	Sectional height	Reference page
Thrust Bearings	Needle roller bearings							F1~
	Roller bearings							
Combined Type Needle Roller Bearings	With thrust ball bearing							G1~
	With thrust roller bearing							
	With angular contact ball bearing							
	With three-point contact ball bearing							
Cam Followers	Caged type							I1~
	Full complement type							
Roller Followers	Separable caged type							I83~
	Non-separable caged type							
	Non-separable full complement type							

A

B

C

D

E

F

G

H

I

J

K

L

M

Features of IKO Bearings

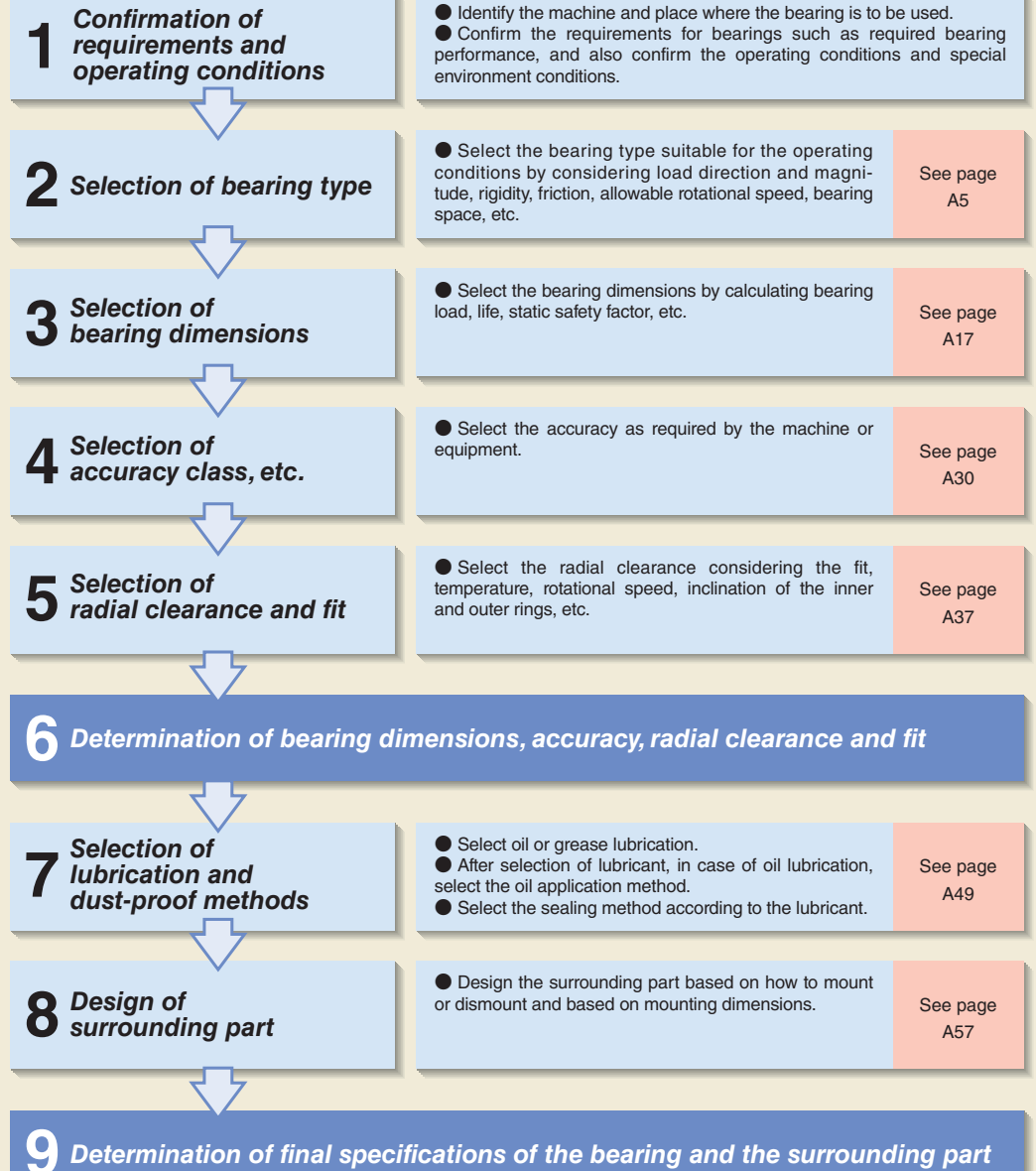
Bearing series	Appearance	Direction of motion	Load direction and capacity	Allowable rotational speed	Friction	Sectional height	Reference page
Crossed Roller Bearings	Caged type, Separator type						J1~
	Full complement type						
	Slim type						
Spherical Bushings	Steel-on-steel type						K1~
	Maintenance-free type						
PILLOBALLS	Insert type, Lubrication type						K29~
	Die-casting type, Lubrication type						
	Maintenance-free type						
L-Balls	Lubrication type						K45~

Symbol Rotation Oscillating motion Radial load Axial load Light load Medium load Heavy load Especially excellent Excellent Normal

Outline of Bearing Selection

IKO Bearings are available in many types and sizes. To obtain satisfactory bearing performance in machines and equipment, it is essential to select the most suitable bearing by carefully studying the requirements for the application. Although there is no particular procedure or rule for bearing selection, an example of a commonly adopted procedure is shown in the figure below.

An example of procedure for bearing selection



Basic Dynamic Load Rating and Life

Life

Rolling bearings will suffer damage due to various causes during service. Damage such as abnormal wear, seizure, and cracks is caused by improper use, including incorrect mounting, lack of oil, dust intrusion and so on, and can be avoided by remedying these causes. However, bearings will eventually be damaged due to fatigue-flaking even if used properly. When a bearing rotates under load, the raceways and the rolling elements are subjected to repeated stresses concentrated on the part close to the surface. Fatigue, therefore, occurs in the surface layer, producing damage in the form of scaling. This is called flaking (spalling). When this occurs, the bearing can no longer be used.

Bearing Life

Bearing life is defined as the total number of revolutions (or total service hours at a constant rotational speed) before a sign of the first flaking appears on the rolling surface of raceway or rolling elements. However, even when bearings of the same size, structure, material and heat treatment are subjected to the same conditions, the bearing lives will show variation (See Fig. 1.). This results from the statistical nature of the fatigue phenomenon. In selecting a bearing, it is incorrect to take an average life for all bearings as the design standard. It is more practical to consider a bearing life that is reliable for the greater proportion of bearings used. Therefore, the basic rating life defined in the following is used.

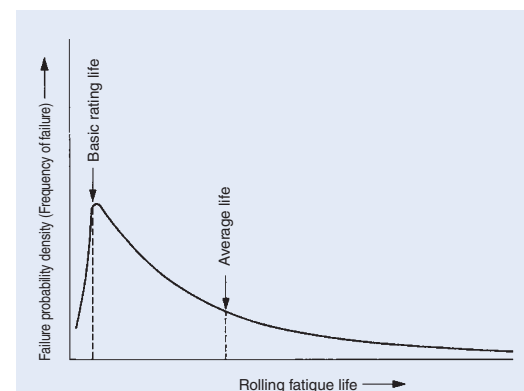


Fig. 1 Variation of rolling fatigue life

Basic rating life

The basic rating life is defined as the total number of revolutions that 90% of a group of identical bearings can be operated individually under the same conditions free from any material damage caused by rolling fatigue.

For rotation at a constant rotational speed, the basic rating life can be represented by the total service hours.

Basic dynamic load rating

The basic dynamic load rating is defined as the constant radial load (in the case of radial bearings) or the constant axial load acting along the bearing central axis (in the case of thrust bearings) that allows a basic rating life of 1,000,000 revolutions.

Calculation of rating life

The relationship among the basic rating life, basic dynamic load rating and dynamic equivalent load (bearing load) of rolling bearings is as follows:

$$L_{10} = \left(\frac{C}{P}\right)^p \dots\dots\dots(1)$$

- where, L_{10} : Basic rating life, 10^6 rev.
- C : Basic dynamic load rating, N
- P : Dynamic equivalent load, N
- p : Exponent, Roller bearing: 10/3
Ball bearing: 3

Accordingly, when the rotational speed per minute is given, the basic rating life is represented as the total service hours according to the following equations:

$$L_h = \frac{10^6 L_{10}}{60n} = 500 f_h^p \dots\dots\dots(2)$$

$$f_h = f_n \frac{C}{P} \dots\dots\dots(3)$$

$$f_n = \left(\frac{33.3}{n}\right)^{1/p} \dots\dots\dots(4)$$

- where, L_h : Basic rating life represented by service hours, h
- n : Rotational speed, min^{-1}
- f_h : Life factor
- f_n : Velocity factor

In addition, the rating life can be calculated by obtaining f_h and f_n from the life calculation scales of Fig. 2.

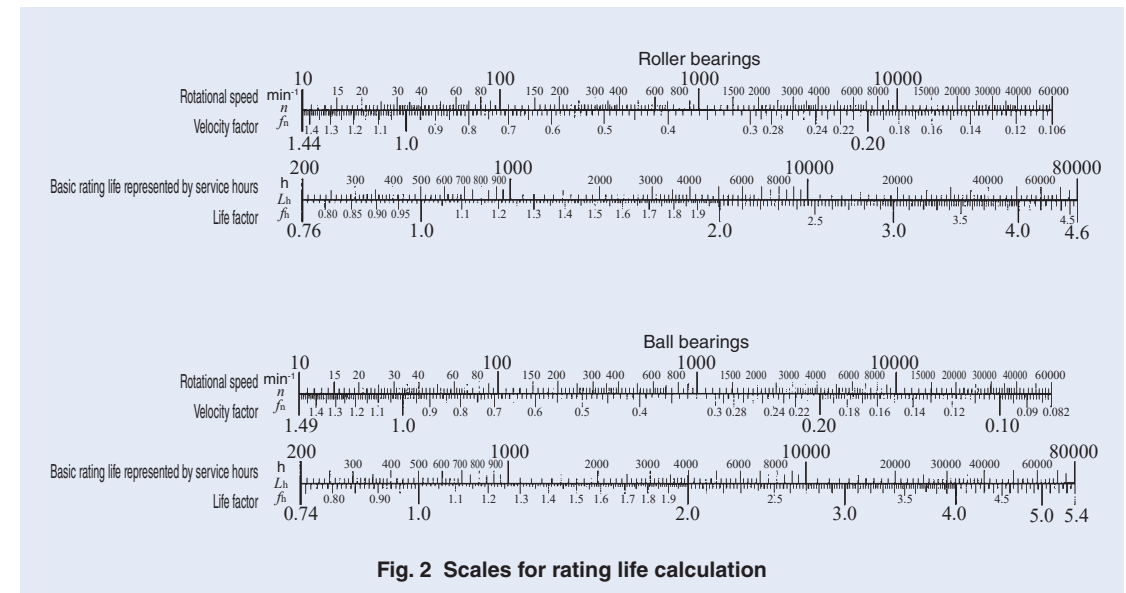


Fig. 2 Scales for rating life calculation

Bearing life factors for various machines

The required life of the bearing must be determined according to the machine in which the bearing is to be used and the operating conditions.

Table 1 shows reference values of life factors for selecting a bearing for each machine.

Table 1 Life factor of bearings f_h for various machines

Operating conditions	Machine and life factor f_h				
	~ 3	2 ~ 4	3 ~ 5	4 ~ 7	6 ~
Occasional or short term usage	• Power tools	• Agricultural machines			
Infrequent usage but requiring reliable operation		• Construction machinery	• Conveyors • Elevators		
Intermittent operation but for comparatively long periods	• Roll neck of rolling mills	• Small motors • Deck cranes • General cargo cranes • Passenger cars	• Factory motors • Machine tools • General gear units • Printing machines	• Crane sheaves • Compressors • Important gear units	
Operated in excess of 8 hours per day or continuously for an extended time		• Escalators	• Centrifugal separators • Blowers • Wood working machines • Plastic extruding machines		• Paper making machines
Continuous use for 24 hours and accidental stops not allowed					• Water supply equipment • Power station equipment



Life of oscillating bearing

The life of an oscillating bearing can be obtained from equation (5).

$$L_{OC} = \frac{90}{\theta} \left(\frac{C}{P}\right)^p \dots\dots\dots (5)$$

where, L_{OC} : Basic rating life of oscillating bearing, 10^6 cycles
 2θ : Oscillating angle, deg. (See Fig.3)
 P : Dynamic equivalent load, N

Therefore, when the oscillating frequency $n_1 \text{min}^{-1}$ is given, the basic rating life as represented by total oscillating hours can be obtained by substituting n_1 for n in equation (2) on page A17.

When 2θ is small, an oil film cannot be formed easily between the contact surfaces of the raceway and the rolling elements. This may cause fretting corrosion. In this case, please consult IKO.

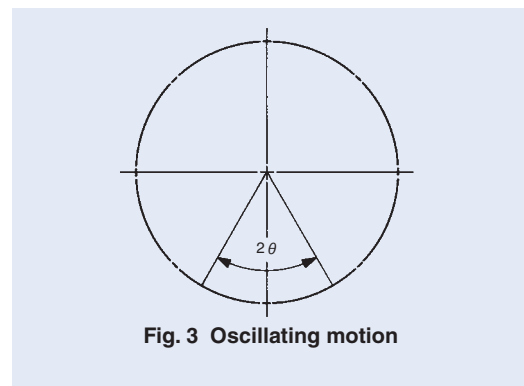


Fig. 3 Oscillating motion

Corrected rating life

When a rolling bearing is used in ordinary applications, the basic rating life can be calculated by equations (1) and (2) mentioned previously.

This basic rating life applies to bearings which require a reliability of 90%, have ordinary bearing properties being made of materials of ordinary quality for rolling bearings, and are used under ordinary operating conditions.

In some applications, however, it is necessary to obtain a rating life that applies to bearings which require high reliability, have special bearing properties or are used under special operating conditions. The corrected rating life for these special cases can be obtained from the following equation by using the

bearing life adjustment factors a_1 , a_2 and a_3 , respectively.

$$L_{na} = a_1 a_2 a_3 L_{10} \dots\dots\dots (6)$$

where, L_{na} : Corrected rating life, 10^6 rev.
 a_1 : Life adjustment factor for reliability
 a_2 : Life adjustment factor for special bearing properties
 a_3 : Life adjustment factor for operating conditions

Life adjustment factor for reliability a_1

The reliability of rolling bearings is defined as the proportion of bearings having a life equal to or greater than a certain specified value when a group of identical bearings are operated under identical conditions. With respect to individual bearings, it refers to the probability of the life of a bearing being equal to or greater than a certain specified value.

The corrected rating life for a reliability of $(100-n)\%$ can be obtained using equation (6). Table 2 shows the values of the life adjustment factor a_1 for various reliabilities.

Table 2 Life adjustment factor for reliability a_1

Reliability %	L_n	a_1
90	L_{10}	1
95	L_5	0.62
96	L_4	0.53
97	L_3	0.44
98	L_2	0.33
99	L_1	0.21

Life adjustment factor for special bearing properties a_2

The bearing life is extended or shortened according to the quality of the material, the manufacturing technology of the bearing and its internal design. For these special bearing life properties, the life is corrected by the life adjustment factor for special bearing properties a_2 .

The table of dimensions for IKO Bearings shows the values of the basic dynamic load rating which are determined taking into consideration the fact that bearing life has been extended by improved quality of materials and advances in manufacturing technologies. Therefore, the bearing life is calculated using equation (6) usually assuming $a_2 = 1$.

Life adjustment factor for operating conditions a_3

This factor helps take into account the effects of operating conditions, especially lubrication on the bearing. The bearing life is limited by the phenomenon of fatigue which occurs, in general, beneath surfaces subjected to repeated stresses. Under good lubrication conditions where the rolling element and raceway surfaces are completely separated by an oil film and surface damage can be disregarded, a_3 is set to be 1. However, when conditions of lubrication are not good, namely, when the viscosity of the lubricating oil is low or the peripheral speed of the rolling elements is especially low, and so on, $a_3 < 1$ is used.

On the other hand, when lubrication is especially good, a value of $a_3 > 1$ can be used. When lubrication is not good and $a_3 < 1$ is used, the life adjustment factor a_2 cannot generally exceed 1.

When selecting a bearing according to the basic dynamic load rating, it is recommended that a suitable value for reliability factor a_1 is chosen for each application. The selection should be made using the (C/P) or f_h values determined by machine type and based upon the actual conditions of lubrication, temperature, mounting, etc., which have already been experienced and observed in the same type of machines.

Limiting conditions

These bearing life equations are applicable only when the bearing is mounted and lubricated normally without intrusion of foreign materials and not used under extreme operating conditions.

Unless these conditions are satisfied, the life may be shortened. For example, it is necessary to separately consider the effects of bearing mounting errors, excessive deformation of housing and shaft, centrifugal force acting on rolling elements at high-speed revolution, excessive preload, especially large radial internal clearance of radial bearings, etc.

When the dynamic equivalent load exceeds 1/2 of the basic dynamic load rating, the life equations may not be applicable.

Correction of basic dynamic load rating for temperature and hardness

Temperature factor

The operating temperature for each bearing is determined according to its material and structure. If special heat treatment is performed, bearings can be used at temperatures higher than $+150^\circ\text{C}$. As the allowable contact stress gradually decreases when the bearing temperature exceeds 150°C , the basic dynamic load rating is lowered and can be obtained by the following equation:

$$C_t = f_t C \dots\dots\dots (7)$$

where, C_t : Basic dynamic load rating considering temperature rise, N
 f_t : Temperature factor (See Fig. 4.)
 C : Basic dynamic load rating, N

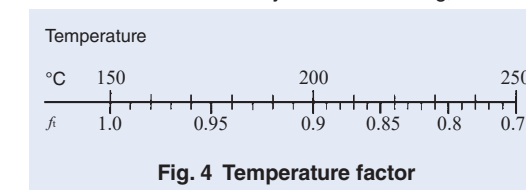


Fig. 4 Temperature factor

Further, if the bearing is used at high temperature, i.e. 120°C or above, the amount of dimensional displacement gets larger. So special heat treatment is necessary. If needed, please contact IKO.

Hardness factor

When the shaft or housing is used as the raceway surface instead of the inner or outer ring, the surface hardness of the part used as the raceway surface should be 58 ~ 64HRC.

If it is less than 58HRC, the basic dynamic load rating is lowered and can be obtained by the following equation:

$$C_H = f_H C \dots\dots\dots (8)$$

where, C_H : Basic dynamic load rating considering hardness, N
 f_H : Hardness factor (See Fig. 5.)
 C : Basic dynamic load rating, N

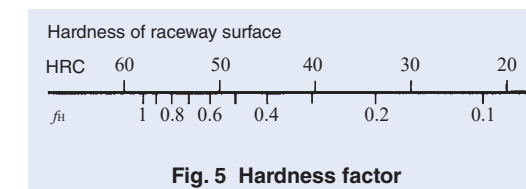


Fig. 5 Hardness factor



Basic Static Load Rating and Static Safety Factor

Basic static load rating

When a bearing at rest sustains a heavy load or a bearing rotating at a relatively low speed receives a heavy shock load, the contact stress may exceed a certain limiting value, producing a local permanent deformation in the raceways or the rolling elements, and subsequently causing noise or vibration or lowering the rotating performance. The basic static load rating is, therefore, determined as a guideline for the maximum allowable load for the bearing at rest, under which the permanent deformation will not exceed a certain limit value, and the lowering of the rotating performance will not occur. Its definition is given as follows.

The basic static load rating is the static load that gives the contact stress shown in Table 3 at the center of the contact area of the rolling element and the raceway receiving the maximum load. A radial load constant in direction and magnitude is used in the case of radial bearings, while an axial load constant in magnitude acting along the bearing central axis is used in the case of thrust bearings.

Table 3

Type of bearing	Contact stress MPa
Roller bearings	4 000
Self-aligning ball bearings	4 600
Other ball bearings	4 200

Static safety factor

The basic static load rating gives the theoretical allowable limit of the static equivalent load. Normally, this limit is corrected by considering the operating conditions and the requirements for the bearing. The correction factor, namely, the static safety factor f_s is defined as in the following equation and its general values are shown in Table 4.

$$f_s = \frac{C_0}{P_0} \dots\dots\dots(9)$$

where, C_0 : Basic static load rating, N
 P_0 : Static equivalent load, N

Table 4 Static safety factor

Operating conditions of the bearing	f_s
When high rotational accuracy is required	≥ 3
For ordinary operation conditions	≥ 1.5
For ordinary operation conditions not requiring very smooth rotation When there is almost no rotation	≥ 1

In case of Shell Type Needle Roller Bearings of which outer ring is drawn from a thin steel plate and then carburized and quenched, it is necessary to use a static safety factor of 3 or more.

Calculation of Bearing Loads

The loads acting on bearings include the weight of the machine parts supported by the bearings, the weight of the rotating body, loads produced when operating the machine, loads by belts or gears transmitting power, and various other loads.

These loads can be divided into radial loads perpendicular to the central axis of the bearings and axial loads parallel to the central axis, and they act independently or in combination with other loads. In addition, the magnitude of vibration or shocks on the bearings varies depending on the application of the machine. Thus, theoretically calculated loads may not always be accurate and have to be corrected by multiplying various empirical factors to obtain the actual bearing loads.

Load distribution to bearings

Table 5 shows examples of calculations where static loads are acting in radial direction.

Table 5 Load distribution to bearings

Example	Bearing load
	$F_{r1} = \frac{dK_{r1} + bK_{r2}}{f}$ $F_{r2} = \frac{cK_{r1} + aK_{r2}}{f}$
	$F_{r1} = \frac{gK_{r1} + bK_{r2} - cK_{r3}}{f}$ $F_{r2} = \frac{aK_{r2} + dK_{r3} - eK_{r1}}{f}$

Load factor

Although radial loads and axial loads can be obtained by calculation, it is not unusual for the actual bearing loads to exceed the calculated loads, due to vibration and shocks produced when operating the machine. The actual bearing load is obtained from the following equation, by multiplying the calculated load by the load factor:

$$F = f_w F_c \dots\dots\dots(10)$$

where, F : Bearing load, N
 f_w : Load factor (See Table 6.)
 F_c : Theoretically calculated load, N

Table 6 Load factor

Operating conditions	Example	f_w
Smooth operation without shocks	Electric motors, Air conditioning equipment, Measuring instruments, Machine tools	1 ~ 1.2
Ordinary operation	Reduction gearboxes, Vehicles, Textile machinery, Paper making machinery	1.2 ~ 1.5
Operation subjected to vibration and shocks	Rolling mills, Rock crushers, Construction machinery	1.5 ~ 3

Bearing loads in case of belt or chain transmission

When power is transmitted by a belt or chain, the load acting on the pulley or sprocket wheel is obtained from the following equations:

$$T = 9550000 \frac{H}{n} \dots\dots\dots(11)$$

$$K_t = \frac{T}{R} \dots\dots\dots(12)$$

- where, T : Torque acting on pulley or sprocket wheel, N-mm
 K_t : Effective transmitting force of belt or chain, N
 H : Transmitting power, kW
 n : Rotational speed, min⁻¹
 R : Effective radius of pulley or sprocket wheel, mm

For belt transmission, the load K_r acting on the pulley shaft is obtained from the following equation, multiplying the effective transmitting force K_t by the belt factor f_b shown in Table 7.

$$K_r = f_b K_t \dots\dots\dots(13)$$

Table 7 Belt factor

Type of belt	f_b
V-belts	2 ~ 2.5
Timing belts	1.3 ~ 2
Plain belts (with tension pulley)	2.5 ~ 3
Plain belts	4 ~ 5

In the case of chain transmission, a value of 1.2 to 1.5 is taken as the chain factor corresponding to f_b . The load acting on the sprocket wheel shaft is obtained from equation (13) in the same manner as the belt transmission.

Bearing loads in case of gear transmission

When power is transmitted by gears, the force acting on the gears varies according to the type of gear. Spur gears produce radial loads only, but helical gears, bevel gears and worm gears produce axial loads in addition to radial loads. Taking the simplest case of spur gears as an example, the bearing load is obtained from the following equations:

$$T = 9550000 \frac{H}{n} \dots\dots\dots(14)$$

$$K_t = \frac{T}{R} \dots\dots\dots(15)$$

$$K_s = K_t \tan \theta \dots\dots\dots(16)$$

$$K_c = \sqrt{K_t^2 + K_s^2} = K_t \sec \theta \dots\dots\dots(17)$$

- where, T : Torque applied to gear, N-mm
 K_t : Tangential force acting on gear, N
 K_s : Radial force acting on gear, N
 K_c : Resultant normal force on gear tooth surface, N
 H : Transmitting power, kW
 n : Rotational speed, min⁻¹
 R : Pitch circle radius of drive gear, mm
 θ : Pressure angle of gear, deg.

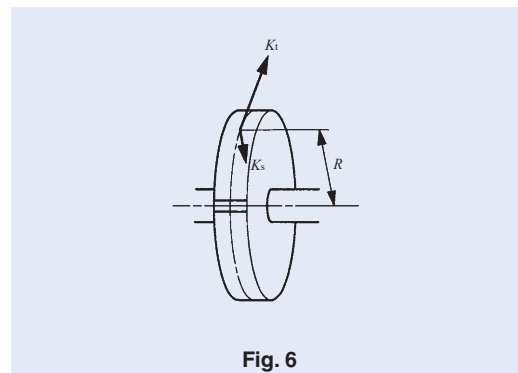


Fig. 6

In this case, the resultant normal force on the tooth surface acts as the radial force to the shaft and the magnitude of vibration or shocks varies depending on the accuracy and surface finish of the gear. Therefore, the radial load K_r applied to the shaft is obtained from the following equation, multiplying the resultant normal force K_c on gear tooth surface by the gear factor f_z shown in Table 8.

$$K_r = f_z K_c \dots\dots\dots(18)$$

Table 8 Gear factor

Type of gear	f_z
Precision gears (Pitch error and form error: Less than 0.02mm)	1.05 ~ 1.1
Ordinary machined gears (Pitch error and form error: 0.02 ~ 0.1mm)	1.1 ~ 1.3

Mean equivalent load corresponding to fluctuating load

When the load applied to the bearing fluctuates, the bearing life is calculated by using the mean equivalent load F_m , which is a constant load that will give the bearing a life equal to that produced under the fluctuating load. The mean equivalent load is obtained from the following equation:

$$F_m = \sqrt[p]{\frac{1}{N} \int_0^N F_n^p dN} \dots\dots\dots(19)$$

- where, F_m : Mean equivalent load, N
 N : Total number of revolutions, rev.
 F_n : Fluctuating load, N
 p : Exponent, Roller bearing = 10/3
 Ball bearing = 3

Table 9 shows examples of the calculation of mean equivalent loads for various fluctuating loads.

Table 9 Mean equivalent load for the fluctuation load

Type of fluctuating load	Mean equivalent load F_m
<p>Step load</p>	$F_m = \sqrt[p]{\frac{1}{N} (F_1^p N_1 + F_2^p N_2 + \dots + F_n^p N_n)}$ <p>where, N_1 : Total number of revolutions under load F_1 rev. N_2 : Total number of revolutions under load F_2 rev. N_n : Total number of revolutions under load F_n rev.</p>
<p>Monotonously changing load</p>	$F_m = \frac{1}{3} (2F_{max} + F_{min})$ <p>where, F_{max} : Maximum value of fluctuating load, N F_{min} : Minimum value of fluctuating load, N</p>
<p>Sinusoidally fluctuating load</p>	$F_m \doteq 0.65 F_{max}$
<p>Sinusoidally fluctuating load</p>	$F_m \doteq 0.75 F_{max}$
<p>Stationary load plus rotating load</p>	$F_m = F_S + F_R - \frac{F_S F_R}{F_S + F_R}$ <p>where, F_S : Stationary load, N F_R : Rotating load, N</p>



Equivalent load

The loads applied to the bearing are divided into radial loads that are applied perpendicular to the central axis and axial loads that are applied in parallel to the central axis. These loads act independently or in combination with other loads.

Dynamic equivalent load

When both radial load and axial load are applied to the bearing simultaneously, the virtual load, acting on the center of the bearing, that will give a life equal to that under the radial load and the axial load is defined as a dynamic equivalent load.

In the case of needle roller bearings, radial bearings receive only radial loads and thrust bearings receive only axial loads. Accordingly, radial loads are directly used in the life calculation of the radial bearings, while axial loads are directly used for the thrust bearings.

[For radial bearings]

$$P_r = F_r \quad \dots\dots\dots(20)$$

[For thrust bearings]

$$P_a = F_a \quad \dots\dots\dots(21)$$

where, P_r : Dynamic equivalent radial load, N
 P_a : Dynamic equivalent axial load, N
 F_r : Radial load, N
 F_a : Axial load, N

Static equivalent load

When both radial load and axial load are applied to the bearing simultaneously, the virtual load, acting on the center of the bearing, that will produce a maximum contact stress on the contact surface between the rolling element and the raceway equal to that given by the radial load and the axial load is defined as a static equivalent load.

In the case of needle roller bearings, radial bearings receive only radial loads and thrust bearings receive only axial loads. Accordingly, radial loads are directly used for the radial bearings, while axial loads are directly used for the thrust bearings.

[For radial bearings]

$$P_{0r} = F_r \quad \dots\dots\dots(22)$$

[For thrust bearings]

$$P_{0a} = F_a \quad \dots\dots\dots(23)$$

where, P_{0r} : Static equivalent radial load, N
 P_{0a} : Static equivalent axial load, N
 F_r : Radial load, N
 F_a : Axial load, N

Boundary Dimensions and Identification Number

Boundary dimensions

Examples of symbols for quantities indicating the boundary dimensions of IKO Needle Roller Bearings are shown below. For details, see the table of dimensions for each model.

Machined Type Needle Roller Bearing

- d : Nominal bearing bore diameter
- D : Nominal bearing outside diameter
- B : Nominal inner ring width
- C : Nominal outer ring width
- F_w : Nominal roller set bore diameter
- r : Chamfer dimensions of inner and outer rings
- $r_{s\min}$: Smallest permissible single chamfer dimensions of inner and outer rings

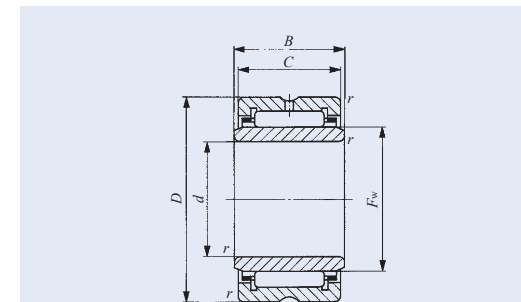


Fig. 7 Machined Type Needle Roller Bearing

Shell Type Needle Roller Bearing

- D : Nominal bearing outside diameter
- F_w : Nominal roller set bore diameter
- C : Nominal outer ring width

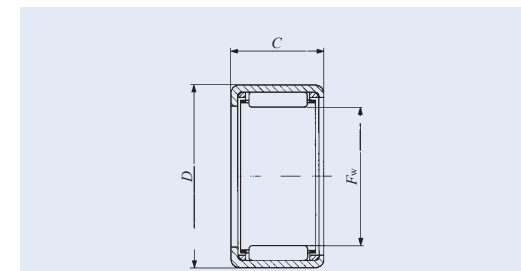


Fig. 8 Shell Type Needle Roller Bearing

Needle Roller Cage

- E_w : Nominal roller set outside diameter
- F_w : Nominal roller set bore diameter
- B_c : Nominal cage width

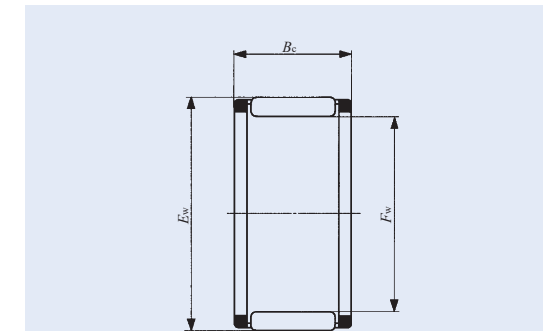


Fig. 9 Needle Roller Cage

Thrust Roller Bearing

- D_c : Nominal cage outside diameter
- d_c : Nominal cage bore diameter
- D_w : Nominal roller diameter

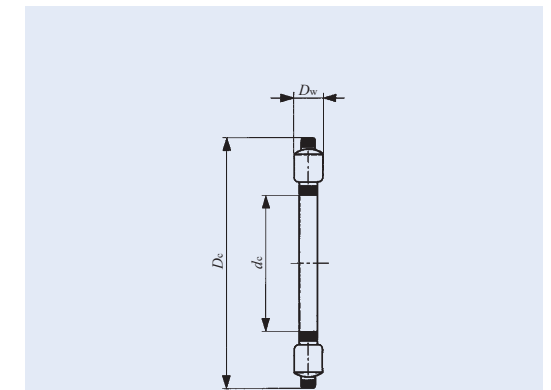


Fig. 10 Thrust Roller Bearing

A
B
C
D
E
F
G
H
I
J
K
L
M

Identification Number

The identification number of IKO Bearings consists of a model number and supplemental codes. The descriptions of typical codes and their arrangements are shown below. There are many codes other than those described. See the section of identification number of each bearing.

Table 10 Arrangement of identification number of bearing

Model number	Model code	①
	Boundary dimensions	②
Supplemental code	Material symbol	③
	Cage symbol	④
	Shield symbol	⑤
	Seal symbol,	⑥
	Bearing ring shape symbol	⑦
	Clearance symbol	⑧
	Classification symbol	⑨

① Model code

The model code represents the bearing series. The features of each bearing series are shown on pages A5 to A15.

② Boundary dimensions

One of the following four kinds of presentation methods is used for showing boundary dimensions in the identification number, which vary depending on the bearing series. Table 11 shows the presentation methods of boundary dimensions for each model code.

- (a) Dimension series + Bore diameter number
- (b) Bore diameter or roller set bore diameter + Outside diameter or roller set outside diameter + Width
- (c) Bore diameter or roller set bore diameter + Width
- (d) Basic diameter

③ Material symbol

Symbol	Type of material
F	Stainless steel for bearing rings and rolling elements

④ Cage symbol

Symbol	Descriptions
N	Made of synthetic resin
V	No cage or full complement

⑤ Seal or shield symbol

Symbol	Descriptions
Z	With dust cover
ZZ	With shields on both sides
U	With a seal on one side
UU	With seals on both sides
S ⁽¹⁾	With ThrustDisk Seals™
2RS	With seals on both sides

Note(1) ThrustDisk Seals™ are embedded on both sides.

⑥ Bearing ring shape symbol

Symbol	Descriptions
NR	With stop ring on outer surface of outer ring
OH ⁽¹⁾	With oil hole in bearing ring
J	No oil hole

Note(1) This differs depending on the type of bearing. See the section of each bearing.

⑦ Clearance symbol

Symbol	Descriptions
C2	C2 clearance
(None)	CN clearance
C3	C3 clearance
C4	C4 clearance
C5	C5 clearance
T1	Special radial clearance (Applicable to Crossed Roller Bearings)
C1	
C2	

⑧ Classification symbol

Symbol	Descriptions
(None)	JIS Class 0
P6	JIS Class 6
P5	JIS Class 5
P4	JIS Class 4

Table 11 Indication of boundary dimensions

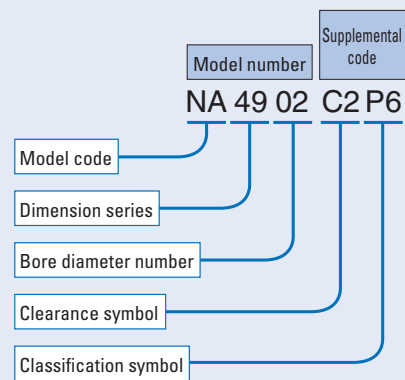
Bearing type	Model number	
	Model code	Indication of boundary dimensions
Shell Type Needle Roller Bearings	TA, TLA, YT, YTL	Roller set bore diameter + Outer ring width
	BA, BHA, YB, YBH	Roller set bore diameter + Outer ring width ⁽¹⁾
Needle Roller Cages for General Usage	KT, KTW	Roller set bore diameter + Roller set outside diameter + Cage width
Needle Roller Cages for Engine Connecting Rods	KT···EG, KTV···EG	Roller set bore diameter + Roller set outside diameter + Cage width
Machined Type Needle Roller Bearings	NA, RNA	Dimension series + Bore diameter number
	TR, TAF, GTR	Roller set bore diameter + Bearing outside diameter + Bearing width
	TRI, TAFI, GTRI	Bearing bore diameter + Bearing outside diameter + Outer ring width
	BR	Roller set bore diameter + Bearing outside diameter + Bearing width ⁽¹⁾
	BRI	Bearing bore diameter + Bearing outside diameter + Outer ring width ⁽¹⁾
Needle Roller Bearings with Separable Cage	RNAF, RNAFW	Roller set bore diameter + Bearing outside diameter + Bearing width
	NAF, NAFW	Bearing bore diameter + Bearing outside diameter + Bearing width
Roller Bearings	NAU, NAG, NAS	Dimension series + Bore diameter number
	TRU	Bearing bore diameter + Bearing outside diameter + Bearing width
Thrust Bearings	NTB, AS, WS, GS	Bearing bore diameter + Bearing outside diameter
	AZ	Bearing bore diameter + Bearing outside diameter + Bearing height
	AZK	Bearing bore diameter + Bearing outside diameter + Roller diameter
Combined Type Needle Roller Bearings	NAX, NBX	Roller set bore diameter + Assembled bearing width
	NAXI, NBXI	Inner ring bore diameter + Assembled bearing width
	NATA, NATB	Dimensional series + Bore diameter number
Cam Followers	CF···B, CFS, NUCF···B	Stud diameter
	CFKR	Bearing outside diameter
	CR···B, CR, CRH···B	Bearing outside diameter ⁽¹⁾
Roller Followers	NAST, NART, NURT	Bearing bore diameter
	CRY	Bearing outside diameter ⁽¹⁾
Crossed Roller Bearings	CRBH, CRBFV, CRBC, CRB, CRBT, CRBTf, CRBS	Bearing bore diameter + Bearing width
Spherical Bushings	SB···A, GE	Inner ring bore diameter
	SBB	Inner ring bore diameter ⁽¹⁾
PILLOBALLs	PB, PHS, POS, PHSB, POSB, PHSA	Inner ring bore diameter
L-Balls	LHSA, LHS	Screw size
Seals for Needle Roller Bearings	OS, DS	Shaft diameter + Seal outside diameter + Seal width
Cir-clips for Needle Roller Bearings	WR	Shaft diameter
	AR	Bore diameter

Note(1) The nominal dimensions of inch series bearings are indicated in units of 1/16 inch.

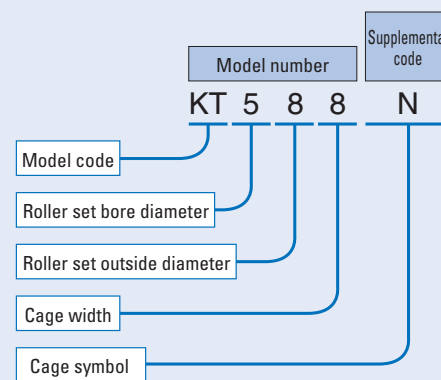


Example of identification number

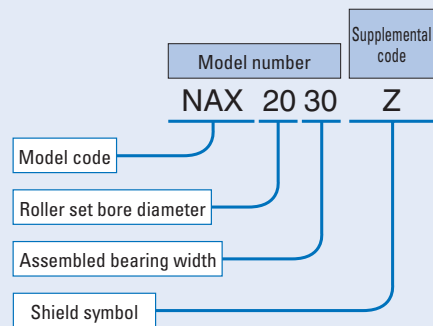
(a) Example of "Dimension series + Bore diameter number"



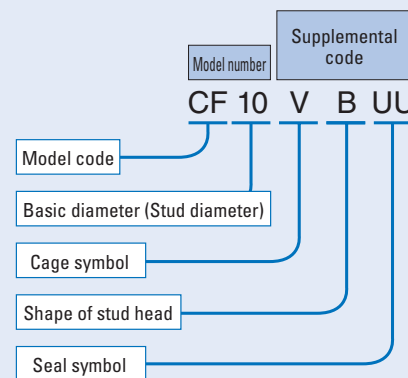
(b) Example of "Bore diameter or roller set bore diameter + Outside diameter or roller set outside diameter + width"



(c) Example of "Bore diameter or roller set bore diameter + width"



(d) Example of "Basic diameter"



Accuracy

The accuracy of IKO Needle Roller Bearings conforms to JIS B 1514-1~-3 (Rolling bearings - Tolerances of bearings), and the dimensional accuracy and rotational accuracy are specified. The specified items are shown in Fig. 11.

Needle Roller Bearings are classified into 4 classes of accuracy. These classes are represented by the numbers 0, 6, 5 and 4, written in order of increasing accuracy.

Table 12 shows the accuracy for the inner rings of radial bearings, Table 13 shows the accuracy for the outer rings of radial bearings, Table 14 shows the tolerances for the smallest single roller set bore diameter of radial bearings, and Table 15 shows the permissible limit values of chamfer dimensions of radial bearings. For thrust bearings, see the section on accuracy of Thrust Bearings. Note that the series of Shell Type Needle Roller Bearings, Roller Bearings, Cam Followers, Roller Followers, Combined Type Needle Roller Bearings, and Crossed Roller Bearings have special accuracy. For further details, see the section on accuracy of each bearing series.

Remarks

The meanings of the new symbols for quantities used for accuracy of radial bearings are as follows:

- ① Δ represents the deviation of a dimension from the specified value.
- ② V represents the variation of a dimension.
- ③ Suffixes s , m , and p represent a single (or actual) measurement, a mean measurement, and a measurement in a single radial plane, respectively.

[Example] V_{dp} means the difference between the largest and the smallest of the bore diameters in a single radial plane (circularity). V_{dmp} means the difference between the largest and the smallest of the single plane mean bore diameters (cylindricity).

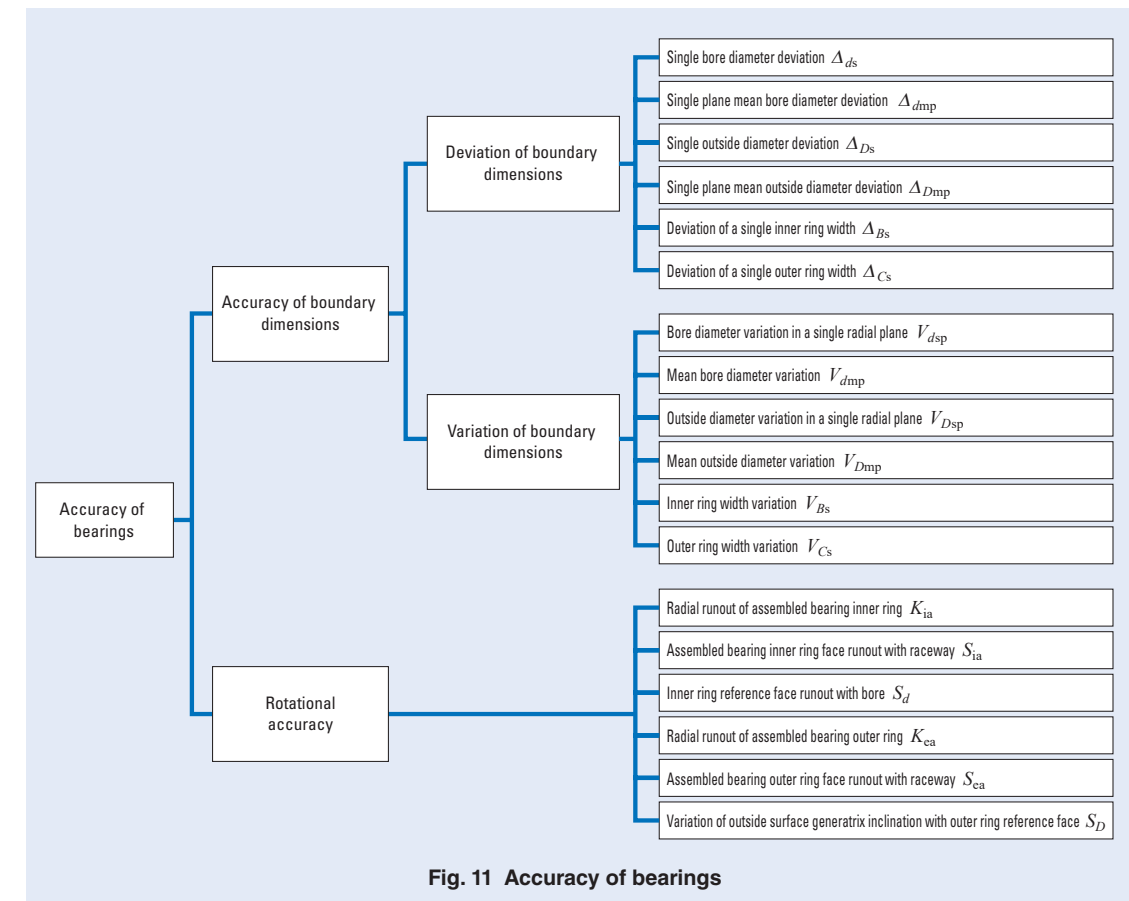


Fig. 11 Accuracy of bearings



Table 12 Tolerances for inner ring

Nominal bearing bore diameter <i>d</i> mm	Δ_{dmp} Single plane mean bore diameter deviation										Δ_{ds} Single bore diameter deviation		V_{dsp} Bore diameter variation in a single radial plane								V_{dmp} Mean bore diameter variation				
	Class 0		Class 6		Class 5		Class 4		Class 4		Diameter series 8, 9 ⁽¹⁾				Diameter series 0 ⁽²⁾				mm						
	High	Low	High	Low	High	Low	High	Low	High	Low	Class 0	Class 6	Class 5	Class 4	Class 0	Class 6	Class 5	Class 4	Class 0	Class 6	Class 5	Class 4	Over	Incl.	
2.5	10	0	-8	0	-7	0	-5	0	-4	0	-4	10	9	5	4	8	7	4	3	6	5	3	2	10	18
30	50	0	-12	0	-10	0	-8	0	-6	0	-6	15	13	8	6	12	10	6	5	9	8	4	3	50	80
120	180	0	-25	0	-18	0	-13	0	-10	0	-10	31	23	13	10	31	23	10	8	19	14	7	5	120	180
315	400	0	-40	0	-30	0	-23					50	38	23		50	38	18		30	23	12		315	400
630	800	0	-75																					630	800
1250	1600	0	-160																					1250	1600

Note⁽¹⁾ Applicable to all series except NAS series
⁽²⁾ Applicable to NAS series
⁽³⁾ Applicable to NATA and NATB series

Table 13 Tolerances for outer ring

Nominal bearing outside diameter <i>D</i> mm	Δ_{Dmp} Single plane mean outside diameter deviation										Δ_{Ds} Single outside diameter deviation		V_{Dsp} ⁽¹⁾ Outside diameter variation in a single radial plane							
	Class 0		Class 6		Class 5		Class 4		Class 4		Open bearing				Bearing with seal or shield					
	High	Low	High	Low	High	Low	High	Low	High	Low	Class 0	Class 6	Class 5	Class 4	Class 0	Class 6	Class 5	Class 4	Class 6	
2.5	6	0	-8	0	-7	0	-5	0	-4	0	-4	10	9	5	4	8	7	4	3	9
30	50	0	-11	0	-9	0	-7	0	-6	0	-6	14	11	7	6	11	9	5	5	13
120	150	0	-18	0	-15	0	-11	0	-9	0	-9	23	19	11	9	23	19	8	7	25
250	315	0	-35	0	-25	0	-18	0	-13	0	-13	44	31	18	13	44	31	14	10	30
500	630	0	-50	0	-38	0	-28					63	48	28		63	48	21		
1000	1250	0	-125																	
1600	2000	0	-200																	
2000	2500	0	-250																	

Note⁽¹⁾ Classes 0 and 6 are applicable to outer rings without stop rings.
⁽²⁾ Applicable to all series except NAS series
⁽³⁾ Applicable to NAS series
⁽⁴⁾ Applicable to NATA and NATB series

unit: μ m

K_{ia} Radial runout of assembled bearing inner ring				S_d Inner ring reference face runout with bore		S_{ia} ⁽³⁾ Assembled bearing inner ring face runout with raceway		Δ_{Bs} Deviation of a single inner ring width								V_{Bs} Inner ring width variation				<i>d</i> Nominal bearing bore diameter		
Class 0	Class 6	Class 5	Class 4	Class 5	Class 4	Class 5	Class 4	Class 0		Class 6		Class 5		Class 4		Class 0	Class 6	Class 5	Class 4	mm		
High	Low	High	Low	High	Low	High	Low	High	Low	High	Low	High	Low	High	Low	High	Low	High	Low	Over	Incl.	
10	6	4	2.5	7	3	7	3	0	-120	0	-120	0	-40	0	-40	15	15	5	2.5	2.5	10	18
30	10	5	4	8	4	8	4	0	-120	0	-120	0	-120	0	-120	20	20	5	2.5	2.5	30	50
120	180	8	6	10	6	10	6	0	-250	0	-250	0	-250	0	-250	30	30	8	5	3	120	180
315	400	15	15	20	15	20	15	0	-400	0	-400	0	-400			40	40	15			315	400
630	800	15	15	20	15	20	15	0	-750	0	-750	0	-750			70	70				630	800
1250	1600	15	15	20	15	20	15	0	-1600	0	-1600	0	-1600			120	140				1250	1600

unit: μ m

V_{Dmp} Mean outside diameter variation				K_{ca} Radial runout of assembled bearing outer ring				S_D Variation of outside surface generatrix inclination with outer ring reference face		S_{ca} ⁽⁴⁾ Assembled bearing outer ring face runout with raceway		Δ_{Cs} Deviation of a single outer ring width		V_{Cs} Outer ring width variation				<i>D</i> Nominal bearing outside diameter				
Class 0	Class 6	Class 5	Class 4	Class 0	Class 6	Class 5	Class 4	Class 5	Class 4	Class 5	Class 4	Class 0, 6, 5, 4		Class 0	Class 6	Class 5	Class 4	mm				
High	Low	High	Low	High	Low	High	Low	High	Low	High	Low	High	Low	High	Low	High	Low	High	Low	Over	Incl.	
6	5	3	2	15	8	5	3	8	4	8	5	5	5	5	2.5	2.5	2.5	6	6	2.5	18	30
30	7	4	3	20	10	7	5	8	4	8	5	5	5	5	2.5	2.5	2.5	30	50	30	50	80
120	14	6	5	40	20	11	7	10	5	13	7	7	7	7	2.5	2.5	2.5	120	150	120	150	180
250	19	7	5	45	23	13	8	10	5	14	8	8	8	8	2.5	2.5	2.5	150	180	150	180	250
500	26	9	7	60	30	18	11	13	8	18	10	10	10	10	2.5	2.5	2.5	250	315	250	315	400
1000	38	14		100	50	25		18	25	25		18	25	25	2.5	2.5	2.5	400	500	400	500	630
1600	55	34	18	120	60	30		20	30	30		20	30	30	2.5	2.5	2.5	630	800	630	800	1000
2000	75	45		140	75										2.5	2.5	2.5	800	1000	800	1000	1250
2500				160											2.5	2.5	2.5	1000	1250	1000	1250	1600
				190											2.5	2.5	2.5	1250	1600	1250	1600	2000
				220											2.5	2.5	2.5	1600	2000	1600	2000	2500
				250											2.5	2.5	2.5	2000	2500	2000	2500	

A
B
C
D
E
F
G
H
I
J
K
L
M

Table 14 Tolerances for smallest single roller set bore diameter $F_{ws \min}^{(1)}$ unit: μm

F_w Nominal roller set bore diameter mm		$\Delta F_{ws \min}$ Deviation of smallest single roller set bore diameter	
Over	Incl.	High	Low
3	6	+ 18	+ 10
6	10	+ 22	+ 13
10	18	+ 27	+ 16
18	30	+ 33	+ 20
30	50	+ 41	+ 25
50	80	+ 49	+ 30
80	120	+ 58	+ 36
120	180	+ 68	+ 43
180	250	+ 79	+ 50
250	315	+ 88	+ 56
315	400	+ 98	+ 62
400	500	+ 108	+ 68

Note⁽¹⁾ This is the diameter of the cylinder used instead of the inner ring, where the radial clearance becomes 0 at least in one radial direction.

Table 15 Permissible limit values for chamfer dimensions of radial bearings unit: mm

$r_s \min$ Smallest permissible single chamfer dimension	Nominal bore diameter d		$r_s \max$ Largest permissible single chamfer dimension	
	Over	Incl.	Radial direction	Axial direction
0.1	—	—	0.55 ⁽²⁾	0.55 ⁽²⁾
0.15	—	—	0.6 ⁽²⁾	0.6
0.2	—	—	0.7 ⁽²⁾	0.8
0.3	—	40	0.8 ⁽²⁾	1
0.4 ⁽¹⁾	—	—	0.8	1.2
0.6	—	40	1.1 ⁽²⁾	2
	—	40	1.3	2
1	—	50	1.5	3
	—	50	1.9	3
1.1	—	120	2	3.5
	—	120	2.5	4
1.5	—	120	2.3	4
	—	120	3	5
2	—	80	3	4.5
	—	80	3.5	5
	—	220	—	6
2.1	—	280	4	6.5
	—	280	4.5	7
2.5 ⁽¹⁾	—	100	3.8	6
	—	100	4.5	6
	—	280	—	7
	—	280	5	8
3	—	280	—	8
	—	280	5.5	8
4	—	—	6.5	9
5	—	—	8	10
6	—	—	10	13

Note⁽¹⁾ Not specified in JIS.

⁽²⁾ The numeric value differs from JIS.

Remark Although the exact shape of the chamfer is not specified, its profile in the axial plane must not extend beyond the imaginary circular arc of radius $r_s \min$ which is tangential to the inner ring side surface and bearing bore surface or to the outer ring side surface and bearing outside surface. (See Fig. 12.)

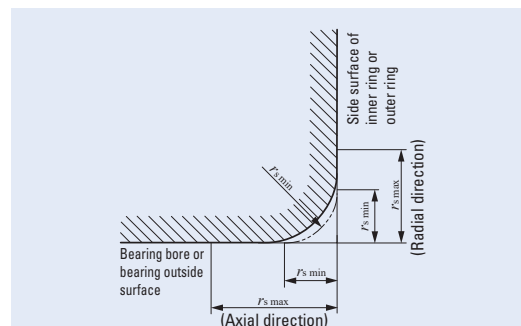


Fig. 12 Permissible values for chamfer dimensions

Methods of Measurement

Measurement of IKO Needle Roller Bearings is based on JIS B 1515-1, -2 (Rolling bearings-Tolerances). Tables 16 and 17 show some examples of the methods.

Special methods are used to measure Shell Type Needle Roller Bearings. Therefore, refer to the section on accuracy for these bearings on page B3.

Table 16 Measurement methods of accuracy of boundary dimensions

Measurement methods		Accuracy and definitions	
Single bore diameter	Zero the gauge indicator to the appropriate size using gauge blocks or a master ring. In several angular directions and in a single radial plane, measure and record the largest and the smallest single bore diameters, $d_{sp \max}$ and $d_{sp \min}$, within the measuring zone (excluding the zone 1.2 times the respective maximum allowable chamfer dimensions of the inner ring face). Repeat angular measurements and recordings in several radial planes to determine the largest and the smallest single bore diameter, $d_s \max$ and $d_s \min$.	d_{mp} Mean bore diameter in a single plane	Calculated mean value of the maximum and minimum values of the single bore diameter within a radial plane. $d_{mp} = \frac{d_{sp \max} + d_{sp \min}}{2}$ d_{sp} : Single bore diameter in a single plane
		Δd_{mp} Deviation of mean bore diameter in a single plane	Deviation of mean bore diameter in a single plane and nominal bore diameter. $\Delta d_{mp} = d_{mp} - d$ d : Nominal bearing bore diameter
		V_{dsp} Variation of bore diameter in a single plane	Deviation of the maximum and minimum values of the single bore diameter within a radial plane. $V_{dsp} = d_{sp \max} - d_{sp \min}$
		V_{dmp} Variation of mean bore diameter	Deviation of the maximum and minimum values of mean bore diameter in a single plane, for individual raceway rings with essentially cylindrical bore diameter surfaces. $V_{dmp} = d_{mp \max} - d_{mp \min}$
		Δd_s Deviation of a single bore diameter	Deviation of single bore diameter and nominal bore diameter. $\Delta d_s = d_s - d$ d_s : Single bore diameter (distance between two parallel straight lines touching the intersection of the single bore diameter surface and the radial plane)
Single outside diameter	Zero the gauge indicator to the appropriate size using gauge blocks or a master. In several angular directions and in a single radial plane, measure and record the largest and the smallest single outside diameters, $D_{sp \max}$ and $D_{sp \min}$, within the measuring zone (excluding the zone 1.2 times the respective maximum allowable chamfer dimensions of the outer ring face). Repeat and record measurements in several radial planes to determine the largest and the smallest single outside diameter, $D_s \max$ and $D_s \min$.	D_{mp} Mean outside diameter in a single plane	Calculated mean value of the maximum and minimum values of the single outside diameter within a radial plane. $D_{mp} = \frac{D_{sp \max} + D_{sp \min}}{2}$ D_{sp} : Single outside diameter in a single plane
		ΔD_{mp} Deviation of mean outside diameter in a single plane	Deviation of mean outside diameter in a single plane and nominal outside diameter. $\Delta D_{mp} = D_{mp} - D$ D : Nominal bearing outside diameter
		V_{Dsp} Variation of outside diameter in a single plane	Deviation of the maximum and minimum values of the single outside diameter within a radial plane. $V_{Dsp} = D_{sp \max} - D_{sp \min}$
		V_{Dmp} Variation of mean outside diameter	Deviation of the maximum and minimum values of mean outside diameter in a single plane, for individual raceway rings with essentially cylindrical outside diameter surfaces. $V_{Dmp} = D_{mp \max} - D_{mp \min}$
		ΔD_s Deviation of a single outside diameter	Deviation of single outside diameter and nominal outside diameter. $\Delta D_s = D_s - D$ D_s : Single outside diameter (distance between two parallel straight lines touching the intersection of the single outside diameter surface and the radial plane)

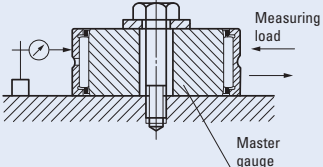
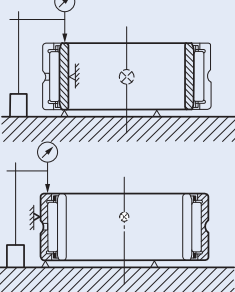
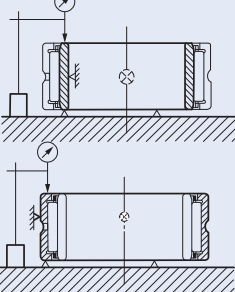
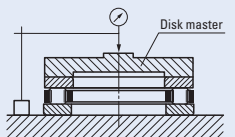
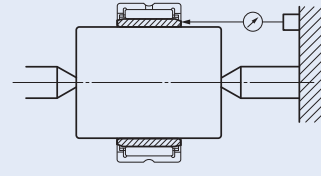
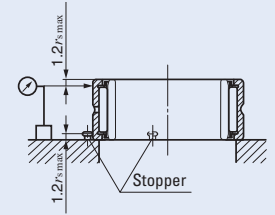
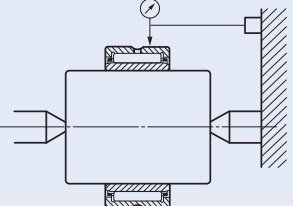
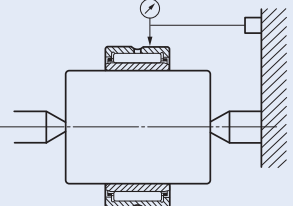
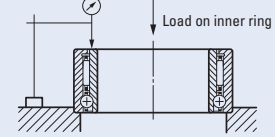
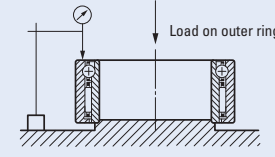
Measurement methods		Accuracy and definitions	
Single bore diameter of rolling element complement	<p>Fasten the master gauge to a surface plate. Position the bearing on the master gauge and apply the indicator in the radial direction near the middle of the width on the ring outside surface. Measure the amount of movement of the outer ring in the radial direction by applying sufficient load on the outer ring in the same radial direction as that of the indicator and in the opposite radial direction. Record indicator readings at the extreme radial positions of the outer ring. Rotate the bearing and repeat the measurement in several different angular positions to determine the largest and the smallest readings, $F_{ws\ max}$ and $F_{ws\ min}$.</p> 	F_{ws} Single bore diameter of roller complement	In radial bearings without inner rings, the distance between two parallel straight lines touching the intersection of the inscribed circle of roller complement and the radial plane.
		$F_{ws\ min}$ Smallest single bore diameter of roller complement	Remark Diameter of a cylinder where the smallest single bore diameter of roller complement has zero radial clearance in at least one radial direction.
Inner ring width	<p>Zero the gauge indicator to the appropriate height from the reference surface using gauge blocks or a master. Support one face of the inner or outer ring on three equally spaced fixed supports of equal height and provide two suitable radial supports on the bore or outside surface set at 90° to each other to centre the inner or outer ring. Position the indicator against the other face of the ring opposite one fixed support. Rotate the inner or outer ring one revolution and measure and record the largest and the smallest single inner (outer) ring width, $B_{s\ max}$ and $B_{s\ min}$ ($C_{s\ max}$ and $C_{s\ min}$).</p> 	Δ_{Bs} Deviation of a single inner ring width	Deviation of single inner ring width and nominal inner ring width. $\Delta_{Bs} = B_s - B$
		V_{Bs} Variation of inner ring width	Deviation of the maximum and minimum values of the single inner ring width for individual inner rings. $V_{Bs} = B_{s\ max} - B_{s\ min}$
Outer ring width		Δ_{Cs} Deviation of a single outer ring width	Deviation of single outer ring width and nominal outer ring width. $\Delta_{Cs} = C_s - C$
		V_{Cs} Variation of outer ring width	Deviation of the maximum and minimum values of the single outer ring width for individual outer rings. $V_{Cs} = C_{s\ max} - C_{s\ min}$
Bearing height	<p>Support the bearing on a surface plate. Zero the gauge indicator to an appropriate height from the surface plate using gauge blocks or a master. Place a plate of known thickness on the bearing assembly, apply a dynamically stable coaxial load, and position the indicator over the centre of the plate. Rotate the housing washer several times, to be sure to reach the smallest height, and take indicator readings.</p> 	Δ_{Ts} Deviation of the actual bearing height	Deviation of actual bearing height and nominal bearing height of the thrust bearing. $\Delta_{Ts} = T_s - T$ T_s : Actual bearing height T : Nominal bearing height

Table 17 Measurement methods for rotational accuracy

Accuracy	Measurement methods	
S_d Perpendicularity of inner ring face with respect to the bore	Use a precision arbor having a taper of approximately 1 : 5 000 on diameter. Mount the bearing assembly on the tapered arbor and place the arbor between two centres so that it can be accurately rotated. Position the indicator against the reference face of the inner ring at a radial distance from the arbor axis of half the mean diameter of the face. Take indicator readings while rotating the inner ring one revolution.	
S_D Perpendicularity of outer ring outside surface with respect to the face	Support the reference face of the outer ring on a surface plate leaving the inner ring, if an assembled bearing, free. Locate the outer ring cylindrical outside surface against two supports set at 90° to each other to centre the outer ring. Position the indicator directly above one support. The indicator and the two supports are axially located at the extremes of the measurement zone (positions 1.2 times the respective maximum allowable chamfer dimensions of the outer ring face). Take indicator readings while rotating the outer ring one revolution.	
K_{ia} Radial runout of inner ring of assembled bearing	Use a precision arbor having a taper of approximately 1 : 5 000 on diameter. Mount the bearing assembly on the tapered arbor and place the arbor between two centres so that it can be accurately rotated. Position the indicator against the outside surface of the outer ring as close as possible to the middle of the outer ring raceway. Hold the outer ring to prevent rotation but ensure its weight is supported by the rolling elements. Take indicator readings while rotating the arbor one revolution.	
K_{ea} Radial runout of outer ring of assembled bearing	Use a precision arbor having a taper of approximately 1 : 5 000 on diameter. Mount the bearing assembly on the tapered arbor and place the arbor between two centres so that it can be accurately rotated. Position the indicator against the outside surface of the outer ring as close as possible to the middle of the outer ring raceway. Hold the inner ring stationary. Take indicator readings while rotating the outer ring one revolution.	
S_{ia} Axial runout of inner ring of assembled bearing	Support the reference face of the outer ring on a surface plate with a pilot for centering the outside diameter of the ring. Apply a dynamically stable coaxial load to the reference face of the inner ring in order to ensure contact between rolling elements and raceways. Position the indicator against the reference face of the inner ring and take indicator readings while rotating the inner ring one revolution.	
S_{ea} Axial runout of outer ring of assembled bearing	Support the reference face of the inner ring on a surface plate with a pilot for centering in the bore of the inner ring. Apply a dynamically stable coaxial load to the reference face of the outer ring in order to ensure contact between rolling elements and raceways. Position the indicator against the reference face of the outer ring and take indicator readings while rotating the outer ring one revolution.	

Clearance

The clearances between the bearing rings and rolling elements are known as bearing clearances. When either the inner or outer ring is fixed and a specified measuring load is applied to the free bearing ring inward and outward alternately in the radial direction, the displacement of the free bearing is referred to as the radial internal clearance. The amount of measuring load in this case is extremely small, and its values are specified in JIS B 1515-2 (Rolling bearings-Tolerances-Part2:Measuring and gauging principles and methods).

① Table 18 shows the radial internal clearances of Needle Roller Bearings with Inner Ring based on JIS B 1520 (Rolling bearings-Radial internal clearance). The radial internal clearances are classified into C2, CN, C3, C4, and C5, with clearances increasing in this order. CN is used under normal operating conditions. When a smaller range in radial internal clearance than the values shown in Table 18 is required, please consult IKO.

② In the case of Shell Type Needle Roller Bearings, the correct dimensional accuracy is achieved only after the bearings are press-fitted into the specified housing bore. Therefore, the clearances shown in Table 18 are not applicable. See page B5.

③ For the radial internal clearances of Cam Followers, Roller Followers and Crossed Roller Bearings, see the relevant section for each bearing.

Table 18 Radial internal clearances of Needle Roller Bearings

unit: μm

d Nominal bore diameter mm		Classification of clearances									
		C2		CN		C3		C4		C5	
Over	Incl.	Min.	Max.	Min.	Max.	Min.	Max.	Min.	Max.	Min.	Max.
—	10	0	25	20	45	35	60	50	75	—	—
10	24	0	25	20	45	35	60	50	75	65	90
24	30	0	25	20	45	35	60	50	75	70	95
30	40	5	30	25	50	45	70	60	85	80	105
40	50	5	35	30	60	50	80	70	100	95	125
50	65	10	40	40	70	60	90	80	110	110	140
65	80	10	45	40	75	65	100	90	125	130	165
80	100	15	50	50	85	75	110	105	140	155	190
100	120	15	55	50	90	85	125	125	165	180	220
120	140	15	60	60	105	100	145	145	190	200	245
140	160	20	70	70	120	115	165	165	215	225	275
160	180	25	75	75	125	120	170	170	220	250	300
180	200	35	90	90	145	140	195	195	250	275	330
200	225	45	105	105	165	160	220	220	280	305	365
225	250	45	110	110	175	170	235	235	300	330	395
250	280	55	125	125	195	190	260	260	330	370	440
280	315	55	130	130	205	200	275	275	350	410	485
315	355	65	145	145	225	225	305	305	385	455	535
355	400	100	190	190	280	280	370	370	460	510	600
400	450	110	210	210	310	310	410	410	510	565	665
450	500	110	220	220	330	330	440	440	550	625	735

Remark For bearings with CN clearance, no symbol is attached to the identification number. In the case of bearings with C2, C3, C4 and C5 clearances, these symbols are attached to the identification number.
Example NA 4905 C2

Selection of clearance

Radial clearances of needle roller bearings change according to bearing fit, temperature difference between bearing rings and rolling elements, loads, etc., and these factors greatly influence bearing life, accuracy, noise, generation of heat, etc. If radial clearances are too large, noise and vibration will increase, and if they are too small, abnormally great forces are exerted on the contact areas between raceways and rolling elements, resulting in abnormally high heat generation and a decrease in bearing life. Therefore, in the ideal case, the clearance provided before mounting should be such that it will become zero or slightly larger when the bearing has reached steady-state operation and the temperature has become constant (saturation temperature). However, it is difficult to achieve this ideal state for all bearings. Under general operating conditions, bearings with CN clearance are most widely used, and are manufactured to provide satisfactory performance when fitted according to Tables 21 and 22.

When radial internal clearances other than CN are used, refer to Table 19.

Table 19 Examples of selecting radial internal clearances other than CN clearance

Operating conditions	Selection of clearance
When heavy loads and shock loads are applied, and amount of interference is great.	C3 or larger clearance
When directionally indeterminate loads are applied, and a tight fit is required for both inner and outer rings.	
When temperature of inner ring is much higher than that of outer ring.	
When shaft deflection and/or mounting error to the housing are great.	
When less noise and vibration are required. When a loose fit is required for both inner and outer rings. When preload is required.	C2 or smaller clearance

Reduction of radial clearances by fit

When the inner or outer rings are interference fitted onto shafts and into housings, respectively, they expand or shrink due to elastic deformation. As the result, the radial clearances are reduced. These reduced radial clearances are called residual (internal) clearances.

The amount of reduction is obtained by the following equation, and it is generally 70 to 90% of the interference amount.

$$\Delta_C = \Delta_F + \Delta_E \dots\dots\dots(24)$$

where, Δ_C : Amount of reduction of the radial clearance, mm
 Δ_F : Amount of expansion of the outside diameter of inner ring, mm
 Δ_E : Amount of shrinkage of the bore diameter of outer ring, mm

① Amount of expansion of the outside diameter of inner ring

· With solid shaft

$$\Delta_F = \Delta_{de} \frac{d}{F} \dots\dots\dots(25)$$

· With hollow shaft

$$\Delta_F = \Delta_{de} \frac{d}{F} \frac{1 - (d_i/d)^2}{1 - (d/F)^2 (d_i/d)^2} \dots\dots(26)$$

where, Δ_{de} : Effective interference of inner ring, mm
 d : Bore diameter of inner ring, mm
 F : Outside diameter of inner ring, mm
 d_i : Bore diameter of hollow shaft, mm

② Amount of shrinkage of the bore diameter of outer ring

· With steel housing ($D_0 = \infty$)

$$\Delta_E = \Delta_{De} \frac{E}{D} \dots\dots\dots(27)$$

· With steel housing ($D_0 \neq \infty$)

$$\Delta_E = \Delta_{De} \frac{E}{D} \frac{1 - (D/D_0)^2}{1 - (E/D)^2 (D/D_0)^2} \dots\dots(28)$$

where, Δ_{De} : Effective interference of outer ring, mm
 D : Outside diameter of outer ring, mm
 E : Bore diameter of outer ring, mm
 D_0 : Outside diameter of housing, mm

Reduction of radial clearances due to temperature differences between inner and outer rings

Frictional heat generated by rotation is dissipated through the shafts and housings as well as through oil and air. Under general operating conditions, heat dissipation is larger on the housing side compared with that on the shaft side, and the temperature of the outer ring is usually lower than that of the inner ring. During operation, the temperature of the rolling elements is the highest, followed by that of the inner ring and that of the outer ring. The amount of thermal expansion, therefore, varies, and the radial clearances are reduced. This reduced radial clearance is called the effective (internal) clearance, and the amount of reduction is obtained by the following equation:



$$\Delta \delta = \alpha \Delta_t E \dots\dots\dots(29)$$

where, $\Delta \delta$: Reduction of radial clearance, mm
 α : Coefficient of linear expansion for bearing steel
 $\cong 12.5 \times 10^{-6} \text{ 1/}^\circ\text{C}$
 Δ_t : Temperature difference between the outer ring and the inner ring plus rolling elements considered as one unit, $^\circ\text{C}$
 E : Bore diameter of outer ring, mm

The temperature difference Δ_t is considered to be 5 ~ 10 $^\circ\text{C}$ under normal operating conditions and 15 ~ 20 $^\circ\text{C}$ at high rotational speeds. Therefore, when the temperature difference is great, a correspondingly larger radial internal clearance must be selected.

Fit

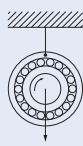

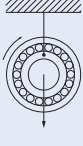
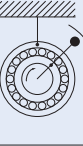
Purpose of fit

To achieve the best performance of needle roller bearings, it is important that the bearing rings are correctly fitted onto the shaft and into the housing.

The purpose of fit is to provide the appropriate amount of interference required between the inner ring and the shaft or between the outer ring and the housing, to prevent harmful mutual slippage.

If the interference is insufficient, it will cause a harmful relative displacement, known as creep, between the fitted surfaces in the circumferential direction. This may lead to abnormal wear of fitted surfaces, intrusion of wear particles into the bearing, generation of abnormal heat, vibration, etc. Therefore, a suitable fit must be selected.

Table 20 Nature of radial load and fit

Nature of the load		Rotating conditions	Fit	
			Inner ring	Outer ring
Rotating load on inner ring Stationary load on outer ring		Inner ring : Rotating Outer ring : Stationary Load direction : Fixed	Interference fit	Clearance fit
		Inner ring : Stationary Outer ring : Rotating Load direction : Rotating with outer ring		
Rotating load on outer ring Stationary load on inner ring		Inner ring : Stationary Outer ring : Rotating Load direction : Fixed	Clearance fit	Interference fit
		Inner ring : Rotating Outer ring : Stationary Load direction : Rotating with inner ring		
Directionally indeterminate load	The load direction is not fixed, including cases where the load direction is fluctuating or there is an unbalanced load.	Inner ring : Rotating or stationary Outer ring : Rotating or stationary Load direction : Not fixed	Interference fit	Interference fit

Conditions for determination of fit

When determining a suitable fit for a bearing, it is necessary to consider various conditions such as nature and magnitude of the load, temperature, required rotational accuracy, material/finish grade/thickness of the shaft and housing, ease of mounting and dismounting, etc.

1 Nature of load and fit

Basically, the appropriate fit depends on whether the load direction is rotational or stationary in relation to the inner and outer rings.

The relationship between the nature of radial loads and the fit is, in general, based on Table 20.

2 Load amount and interference

The greater the load, the larger the interference must be.

When selecting an interference between the inner ring and the shaft, it is necessary to estimate the reduction of interference due to the radial load. The amount of reduction of interference is obtained by the following equations.

· When $F_r \leq 0.2C_0$

$$\Delta_{dF} = 0.08 \sqrt{\frac{d}{B}} F_r \times 10^{-3} \dots\dots\dots(30)$$

· When $F_r > 0.2C_0$

$$\Delta_{dF} = 0.02 \frac{F_r}{B} \times 10^{-3} \dots\dots\dots(31)$$

where, F_r : Radial load applied to bearing, N
 C_0 : Basic static load rating, N
 Δ_{dF} : Amount of reduction of inner ring interference, mm
 d : Bore diameter of inner ring, mm
 B : Width of inner ring, mm

3 Temperature conditions and change of interference

The interference of fitted surfaces is also influenced by the temperature difference between the bearing and the shaft and housing. For example, when steam is flowing through a hollow shaft, or when the housing is made of light metal, it is necessary to take into consideration the differences in temperature, the coefficient of linear expansion and other such factors.

Usually, the interference of the inner ring decreases as the bearing temperature increases during operation. If the temperature difference between the inside of the bearing and the outside of the housing is taken

as Δ_T , the temperature difference between the inner ring and the shaft can be estimated to be (0.1 ~ 0.15) Δ_T . Accordingly, the amount of reduction of the inner ring interference is obtained by the following equation.

$$\Delta_{dT} = (0.1 \sim 0.15) \Delta_T \alpha d \cong 0.0015 \Delta_T d \times 10^{-3} \dots\dots(32)$$

where, Δ_{dT} : Reduction amount of inner ring interference due to temperature difference, mm

Δ_T : Temperature difference between the inside of the bearing and the outside of the housing, $^\circ\text{C}$

α : Coefficient of linear expansion for bearing steel
 $\cong 12.5 \times 10^{-6} \text{ 1/}^\circ\text{C}$

d : Bore diameter of inner ring, mm

4 Shaft finish grade and interference

Since peaks of surface roughness of the fitted surface are crushed down when fitting the bearing, the effective interference becomes smaller than the apparent interference obtained by measurements, and it is generally obtained by the following equations.

· For ground shaft

$$\Delta_{de} = \frac{d}{d+2} \Delta_{df} \dots\dots\dots(33)$$

· For machined shaft

$$\Delta_{de} = \frac{d}{d+3} \Delta_{df} \dots\dots\dots(34)$$

where, Δ_{de} : Effective interference of inner ring, mm
 d : Bore diameter of inner ring, mm
 Δ_{df} : Apparent interference, mm

5 Minimum interference and maximum interference

When the load direction is rotating in relation to the inner ring, the inner ring is fitted with interference to the shaft.

For solid ground steel shafts, the minimum interference (required apparent interference) Δ_{df} is expressed by the following equation which is deduced from equations (30) or (31), (32) and (33).

$$\Delta_{df} \geq \frac{d+2}{d} (\Delta_{dF} + 0.0015 \Delta_T d \times 10^{-3}) \dots\dots(35)$$

It is desired that the maximum interference should be less than 1/1000 of the shaft diameter. In the case of the outer ring, the effective interference varies according to the housing material, thickness, shape, etc., so it is determined empirically.



Selection of fit

When selecting a suitable fit, in addition to the various conditions mentioned above, it is necessary to draw on experience and practical results.

Tables 21 and 22 show the most general fit data.

When a thin housing or a hollow shaft is used, the interference is made larger than an ordinary fit.

The fit between needle roller bearings without inner ring and shafts is based on Table 23.

For the fit between Shell Type Needle Roller Bearings and housing bores, see page B5.

For the fit between inner rings for Shell Type Needle Roller Bearings and shafts, see Table 22.

Table 21 Fit between needle roller bearings and housing bores (Not applicable to Shell Type Needle Roller Bearings)

Operating conditions		Tolerance class of housing bore (1)	Application examples (Reference)
Rotating load on outer ring	Heavy load on thin housing, large shock load	P7 (2)	Flywheels
	Heavy load, normal load	N7 (2)	Wheel bosses, transmission gears
	Light load, fluctuating load	M7	Pulleys, tension pulleys
Directionally indeterminate load	Large shock load	M7	Eccentric wheels, pumps
	Heavy load, normal load	K7	Compressors
	Normal load, light load	J7	Crankshafts, compressors
Stationary load on outer ring	Shock load, heavy load	J7	General bearing applications, gear shafts
	Normal load, light load	H7	General bearing applications
	With heat conduction through shaft	G7	Paper dryers
Light load, normal load, requirements of high-precision rotation and high rigidity		K6	Main spindles of machine tools

Notes(1) This table applies to steel or cast iron housings. For lighter metal, a tighter fit should be selected.

For split housings, do not use a fit tighter than J7.

(2) Care should be taken so that the radial internal clearance is not too small.

Remark Light load, normal load and heavy load represent $P \leq 0.06C$, $0.06C < P \leq 0.12C$, and $0.12C < P$, respectively, where P is the dynamic equivalent radial load and C is the basic dynamic load rating of the bearing to be used.

Table 22 Fit between needle roller bearings with inner ring and shafts

Operating conditions	Shaft dia. mm		Tolerance class of shaft (1)	Application examples (Reference)	
	Over	Incl.			
Stationary load on inner ring	All shaft diameters		g6	Wheels on dead axles	
			h6	Control lever gears	
			h5	Rope sheaves Tension pulleys	
Rotating load on inner ring or Directionally indeterminate load	Light load	—	50	j5 k5 m6 (2) n6 (3)	Electric appliances, Precision machinery Machine tools, Pumps Blowers, Transportation vehicles
		50	100		
		100	200		
		200	—		
	Normal load	—	50	k5 (4)	General bearing applications Pumps, Transmission gearboxes, Wood working machinery, Internal combustion engines
		50	150	m5, m6 (2)	
150		200	n6 (3)		
Heavy load Shock load	—	150	p6 (3)	Industrial vehicles, Construction machinery Crushers	
	150	—	p6 (3)		

Notes(1) This table applies to solid steel shafts.

(2) It is necessary to examine the reduction of radial internal clearances caused by the expansion of inner rings after mounting.

(3) It is necessary to use bearings with radial internal clearances greater than CN clearance.

(4) For NATA and NATB, do not use a tighter fit than k5.

Table 23 Tolerance class of shafts assembled with needle roller bearings without inner ring

Nominal roller set bore diameter mm		Radial internal clearance		
		Smaller than CN clearance	CN clearance	Larger than CN clearance
Over	Incl.	Tolerance class of shaft (1)		
—	65	k5	h5	g6
65	80	k5	h5	f6
80	160	k5	g5	f6
160	180	k5	g5	e6
180	200	j5	g5	e6
200	250	j5	f6	e6
250	315	h5	f6	e6
315	—	g5	f6	d6

Note(1) When the housing bore fit is tighter than K7, the shaft diameter is made smaller by considering shrinkage of roller set bore diameter after mounting.



Table 24 Fit values for radial bearings (JIS Class 0) (Fit with housing bore) unit: μm

Nominal outside diameter mm	Δ_{Dmp} Single plane mean outside diameter deviation			G7	H7	J7	K6	K7	M7	N7	P7
		Over	Incl.	High	Low	Housing	Bearing	Housing	Bearing	Housing	Bearing
3	6	0	-8	-24 ~ -4	-20 ~ 0	-14 ~ 6	-10 ~ 6	-11 ~ 9	-8 ~ 12	-4 ~ 16	0 ~ 20
6	10	0	-8	-28 ~ -5	-23 ~ 0	-16 ~ 7	-10 ~ 7	-13 ~ 10	-8 ~ 15	-4 ~ 19	1 ~ 24
10	18	0	-8	-32 ~ -6	-26 ~ 0	-18 ~ 8	-10 ~ 9	-14 ~ 12	-8 ~ 18	-3 ~ 23	3 ~ 29
18	30	0	-9	-37 ~ -7	-30 ~ 0	-21 ~ 9	-11 ~ 11	-15 ~ 15	-9 ~ 21	-2 ~ 28	5 ~ 35
30	50	0	-11	-45 ~ -9	-36 ~ 0	-25 ~ 11	-14 ~ 13	-18 ~ 18	-11 ~ 25	-3 ~ 33	6 ~ 42
50	80	0	-13	-53 ~ -10	-43 ~ 0	-31 ~ 12	-17 ~ 15	-22 ~ 21	-13 ~ 30	-4 ~ 39	8 ~ 51
80	120	0	-15	-62 ~ -12	-50 ~ 0	-37 ~ 13	-19 ~ 18	-25 ~ 25	-15 ~ 35	-5 ~ 45	9 ~ 59
120	150	0	-18	-72 ~ -14	-58 ~ 0	-44 ~ 14	-22 ~ 21	-30 ~ 28	-18 ~ 40	-6 ~ 52	10 ~ 68
150	180	0	-25	-79 ~ -14	-65 ~ 0	-51 ~ 14	-29 ~ 21	-37 ~ 28	-25 ~ 40	-13 ~ 52	3 ~ 68
180	250	0	-30	-91 ~ -15	-76 ~ 0	-60 ~ 16	-35 ~ 24	-43 ~ 33	-30 ~ 46	-16 ~ 60	3 ~ 79
250	315	0	-35	-104 ~ -17	-87 ~ 0	-71 ~ 16	-40 ~ 27	-51 ~ 36	-35 ~ 52	-21 ~ 66	1 ~ 88
315	400	0	-40	-115 ~ -18	-97 ~ 0	-79 ~ 18	-47 ~ 29	-57 ~ 40	-40 ~ 57	-24 ~ 73	1 ~ 98
400	500	0	-45	-128 ~ -20	-108 ~ 0	-88 ~ 20	-53 ~ 32	-63 ~ 45	-45 ~ 63	-28 ~ 80	0 ~ 108

Remark The negative value denotes a clearance and the positive value denotes an interference.

Table 25 Fit values for radial bearings (JIS Class 0) (Fit with shaft) unit: μm

Nominal bore diameter mm	Δ_{dmp} Single plane mean bore diameter deviation			g6	h5	h6	j5	k5	m5	m6	n6	p6
		Over	Incl.	High	Low	Bearing	Shaft	Bearing	Shaft	Bearing	Shaft	Bearing
3	6	0	-8	-12 ~ 4	-5 ~ 8	-8 ~ 8	-2 ~ 11	1 ~ 14	4 ~ 17	4 ~ 20	8 ~ 24	12 ~ 28
6	10	0	-8	-14 ~ 3	-6 ~ 8	-9 ~ 8	-2 ~ 12	1 ~ 15	6 ~ 20	6 ~ 23	10 ~ 27	15 ~ 32
10	18	0	-8	-17 ~ 2	-8 ~ 8	-11 ~ 8	-3 ~ 13	1 ~ 17	7 ~ 23	7 ~ 26	12 ~ 31	18 ~ 37
18	30	0	-10	-20 ~ 3	-9 ~ 10	-13 ~ 10	-4 ~ 15	2 ~ 21	8 ~ 27	8 ~ 31	15 ~ 38	22 ~ 45
30	50	0	-12	-25 ~ 3	-11 ~ 12	-16 ~ 12	-5 ~ 18	2 ~ 25	9 ~ 32	9 ~ 37	17 ~ 45	26 ~ 54
50	80	0	-15	-29 ~ 5	-13 ~ 15	-19 ~ 15	-7 ~ 21	2 ~ 30	11 ~ 39	11 ~ 45	20 ~ 54	32 ~ 66
80	120	0	-20	-34 ~ 8	-15 ~ 20	-22 ~ 20	-9 ~ 26	3 ~ 38	13 ~ 48	13 ~ 55	23 ~ 65	37 ~ 79
120	140											
140	160	0	-25	-39 ~ 11	-18 ~ 25	-25 ~ 25	-11 ~ 32	3 ~ 46	15 ~ 58	15 ~ 65	27 ~ 77	43 ~ 93
160	180											
180	200											
200	225	0	-30	-44 ~ 15	-20 ~ 30	-29 ~ 30	-13 ~ 37	4 ~ 54	17 ~ 67	17 ~ 76	31 ~ 90	50 ~ 109
225	250											
250	280	0	-35	-49 ~ 18	-23 ~ 35	-32 ~ 35	-16 ~ 42	4 ~ 62	20 ~ 78	20 ~ 87	34 ~ 101	56 ~ 123
280	315											
315	355	0	-40	-54 ~ 22	-25 ~ 40	-36 ~ 40	-18 ~ 47	4 ~ 69	21 ~ 86	21 ~ 97	37 ~ 113	62 ~ 138
355	400											
400	450	0	-45	-60 ~ 25	-27 ~ 45	-40 ~ 45	-20 ~ 52	5 ~ 77	23 ~ 95	23 ~ 108	40 ~ 125	68 ~ 153
450	500											

Remark The negative value denotes a clearance and the positive value denotes an interference.

Design of Shaft and Housing

Accuracy and roughness of shaft and housing

Accuracy and roughness of fitting surface

Since the bearing rings of needle roller bearings are thin, their performance is easily affected by poor accuracy of shafts or housings. Under general operating conditions, the fitting surfaces of shafts and housings can be finished by lathe turning. However, when the load is great and high accuracy and low noise are required, a grinding finish is required.

Table 26 shows the accuracy and roughness of fitting surfaces for general use.

Accuracy and roughness of raceway surface

In case of needle roller bearings unlike other bearings, mating surfaces such as shaft and housing bore surfaces can be used directly as the raceway surfaces. For such use, accuracy and roughness of the raceway surfaces are important because they will influence bearing life, noise and accuracy.

In general, accuracy and roughness of raceway surfaces are based on Table 26.

Inclination of shaft

Shafts and outer rings may have some inclination between them due to deflection of the shaft, machining accuracy of shafts and housings, errors in mounting, etc.

In this case, the use of two or more bearings in tandem arrangement on a single shaft should be avoided. Instead, a bearing with large load ratings should be used.

It is recommended that inclination of shafts be less than 1/1000.

Table 27 Tolerance class IT values for basic dimensions

Basic dimension mm		Tolerance class ⁽¹⁾		
Over	Incl.	IT5	IT6	IT7
		Tolerance μm		
—	3	4	6	10
3	6	5	8	12
6	10	6	9	15
10	18	8	11	18
18	30	9	13	21
30	50	11	16	25
50	80	13	19	30
80	120	15	22	35
120	180	18	25	40
180	250	20	29	46
250	315	23	32	52
315	400	25	36	57
400	500	27	40	63
500	630	30	44	70

Note⁽¹⁾ Based on JIS B 0401.

Table 26 Specifications of shafts and housings for radial needle roller bearings

Item	Shaft		Housing bore	
	Fitting surface	Raceway surface	Fitting surface	Raceway surface
Circularity	$0.3 \times \text{IT6}^{(1)}$	$0.3 \times \text{IT6}^{(1)}$	$0.3 \times \text{IT7}^{(1)}$	$0.3 \times \text{IT7}^{(1)}$
	or $0.3 \times \text{IT5}^{(1)}$	or $0.3 \times \text{IT5}^{(1)}$	or $0.3 \times \text{IT6}^{(1)}$	or $0.3 \times \text{IT6}^{(1)}$
Cylindricity	$0.5 \times \text{IT6}^{(2)}$	$0.3 \times \text{IT6}^{(1)}$	$0.5 \times \text{IT7}^{(2)}$	$0.3 \times \text{IT7}^{(1)}$
	or $0.5 \times \text{IT5}^{(2)}$	or $0.3 \times \text{IT5}^{(1)}$	or $0.5 \times \text{IT6}^{(2)}$	or $0.3 \times \text{IT6}^{(1)}$
Surface roughness $\mu\text{m} R_a$ ($\mu\text{m} R_y$)	0.8 (3.2)	0.2 ⁽³⁾ (0.8)	1.6 (6.3)	0.2 ⁽³⁾ (0.8)
Hardness	—	58 ~ 64HRC ⁽⁴⁾	—	58 ~ 64HRC ⁽⁴⁾

Notes⁽¹⁾ 30% or less of the dimensional tolerance for shafts or housing bores is recommended.

⁽²⁾ 50% or less of the dimensional tolerance for shafts or housing bores is recommended.

⁽³⁾ When required accuracy is not critical, a surface roughness within $0.8 \mu\text{m} R_a$ ($3.2 \mu\text{m} R_y$) is allowable.

⁽⁴⁾ An appropriate thickness of the hardened layer is required.

Remark For tolerance class IT, see Table 27.

Raceway materials and heat treatment

When using shafts and housings as raceways, the following materials are generally used.

High-carbon chromium bearing steel	SUJ2	JIS G 4805
Carburizing steel	SCM415 ~ 421	JIS G 4053
Carburizing steel	SNCM 220	JIS G 4053
Carburizing steel	SCr 420	JIS G 4053
Carburizing steel	SNC 415, 815	JIS G 4053
Carburizing steel	S 15 CK	JIS G 4051

In addition, S50C and S55C (JIS G 4051) can be used after through hardening or induction hardening.

The hardened layer produced by tempering at +160 ~ +180°C after hardening must have a fine uniform martensite microstructure.

When hardening the raceway surface by case hardening or induction hardening, a surface hardness of 58 ~ 64HRC and an appropriate thickness of the hardened layer must be ensured. The minimum effective thickness of the hardened layer after heat treatment and grinding is defined as the distance from the surface to the depth where the hardness is 550HV, and it is obtained by the following equation.

$$E_{ht} \geq 0.8D_w(0.1 + 0.002D_w) \dots\dots\dots(36)$$

where, E_{ht} : Minimum effective thickness of the hardened layer, mm

D_w : Roller diameter, mm

Generally, the required effective thickness of the hardened layer is at least 0.3 mm.

Dimensions related to mounting of bearings

The dimensions of shaft and housing related to mounting of the needle roller bearings are shown in the table of dimensions for each bearing. (See Fig. 13.)

The minimum value of the shaft shoulder diameter d_a which receives the inner ring, and the maximum value of the housing shoulder diameter D_a which receives the outer ring, represent the effective shoulder diameters (excluding the chamfered part) which make proper contact with the side faces of the inner and outer rings respectively.

Also, the maximum value of the shaft shoulder (or inner ring retaining piece) diameter d_a is the dimension related to the ease of mounting/dismounting of the shaft and inner ring to/from the housing and outer ring.

The largest permissible single corner radius $r_{as \max}$ of the shaft and housing must be smaller than the smallest permissible single chamfer dimension $r_{s \min}$ of the bearing so that the side surface of the bearing can make proper contact with the shoulder.

For dimensions of the fillet relief when finishing the shaft or housing by grinding, the values shown in Table 29 are recommended.

For other dimensions related to mounting, see the related section for each bearing as required.

In addition, for ease in dismounting of bearings, it is convenient to make notches in the shoulder of the shaft or housing to allow the insertion of dismounting hooks.

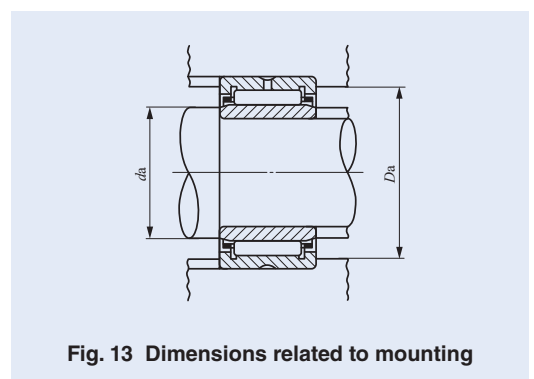


Fig. 13 Dimensions related to mounting

Table 28 Largest permissible single corner radius of shafts and housings $r_{as \max}$

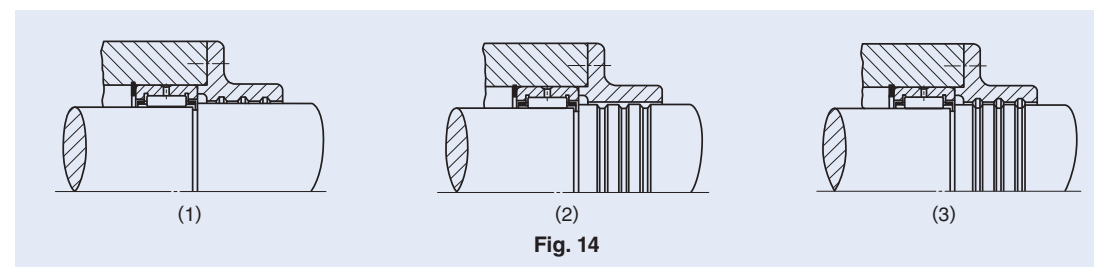
$r_{s \min}$ Smallest permissible single chamfer dimension	$r_{as \max}$ Largest permissible single corner radius of shafts and housings	
unit: mm		
0.1	0.1	
0.15	0.15	
0.2	0.2	
0.3	0.3	
0.4	0.4	
0.6	0.6	
1	1	
1.1	1	
1.5	1.5	
2	2	
2.1	2	
2.5	2	
3	2.5	
4	3	
5	4	

Table 29 Fillet relief dimensions for ground shafts and housings

$r_{s \min}$ Smallest permissible single chamfer dimension	Fillet relief dimensions			
	t	r_{gs}	b	
1	0.2	1.3	2	
1.1	0.3	1.5	2.4	
1.5	0.4	2	3.2	
2	0.5	2.5	4	
2.1	0.5	2.5	4	
3	0.5	3	4.7	
4	0.5	4	5.9	
5	0.6	5	7.4	
6	0.6	6	8.6	
7.5	0.6	7	10	

Sealing

To obtain the best performance of rolling bearings, it is necessary to prevent leakage of lubricant and the



entry of harmful foreign substances, such as dirt, dust and water. For this reason, sealing devices must always work effectively to seal and prevent against dust penetration under all operating conditions. Also, when selecting a suitable sealing method, it is necessary to consider such factors as the type of lubricant, peripheral speed of the seal, operating temperature, shaft eccentricity, seal friction, etc. as well as ease of assembly and disassembly.

Sealing methods are of the non-contact and contact types, and it is necessary to select the appropriate type depending on the application.

Non-contact type sealing method

There are many methods of non-contact type sealing, including the use of oil grooves, flingers and labyrinths, which utilize the centrifugal force and narrow gaps.

Since they do not make direct contact with the shaft or housing, it is unnecessary to consider friction and wear, and the non-contact sealing method is suitable for high speed rotation and high operating temperatures. However, because of gaps, this method is not always sufficient in preventing oil leakage and dust entry when the machine is not in operation.

1 Oil groove

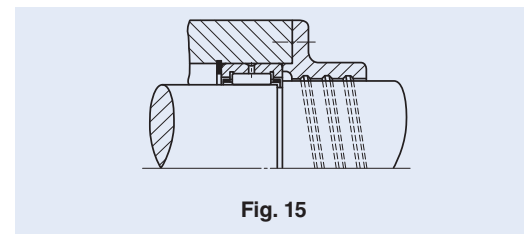
Oil grooves are provided on either the shaft or housing bore, or on both for more effective sealing (See Fig. 14.). The clearance between the shaft and the housing bore should be as small as possible, and the values shown in Table 30 are generally used, taking into consideration errors in machining and assembly, shaft deformation, etc. Three or more grooves are made with a width of 3 ~ 5 mm and a depth of 4 ~ 5 mm. If the grooves are filled with grease, it will be more effective for dust prevention.

As shown in Fig. 15, helical grooves are suitable for horizontal shafts which have a fixed direction of rotation. Right or left handed grooves are used according to the direction of rotation, and they are used for oil lubrication normally in conjunction with a suitable anti-dust device.

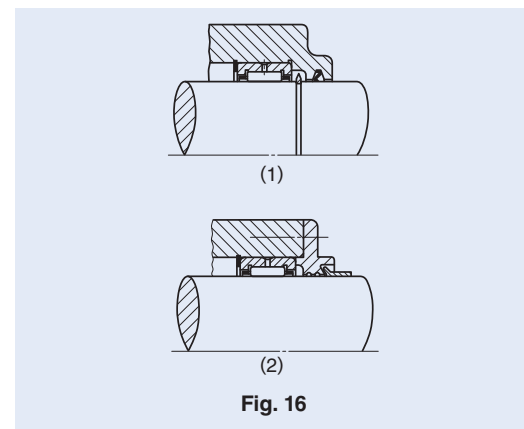


Table 30 Clearance between grooved shaft and housing bore unit: mm

Shaft dia.	Clearance
Incl. 50 mm	0.25 ~ 0.4
Over 50 mm	0.5 ~ 1



② Flinger
The oil flinger is a disk attached to the shaft which throws off oil due to the centrifugal force of rotation and thus prevents oil leakage and the entry of foreign particles. Fig. 16 (1) shows an example in which the flinger is located inside the housing, mainly to prevent oil leakage. Since it sucks in dust and dirt, it should be used in a dust free environment. Fig. 16 (2) shows an example in which the flinger is located outside the housing, and is used in combination with another sealing device, to prevent entry of foreign particles.



③ Labyrinth
Although it is a little difficult to make, the labyrinth is very effective in preventing oil leakage especially at high speeds. At low speeds, filling the labyrinth with grease is effective in preventing the entry of dust. In Fig. 17, it is necessary to split the housing or cover plate into two. In Fig. 18, it is easy to assemble, and if combined with an oil seal, it improves the sealing effect. Table 31 shows the labyrinth clearances generally used.

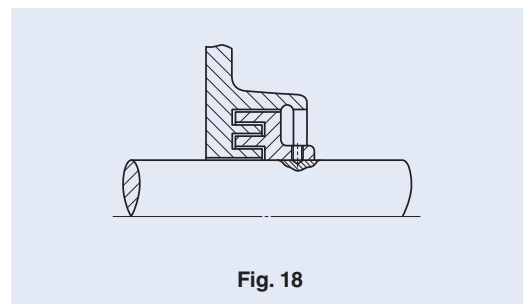
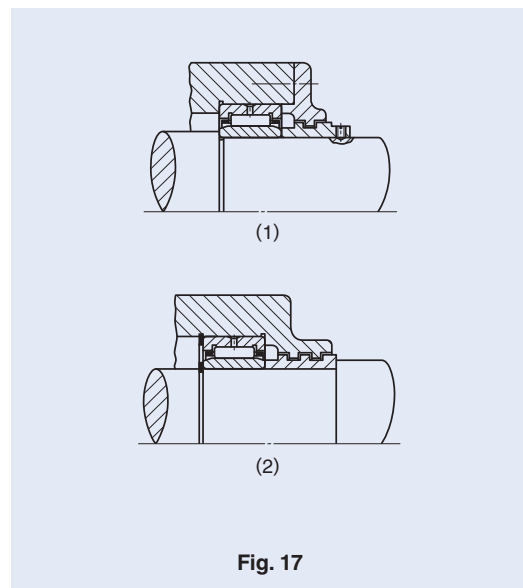


Table 31 Labyrinth clearance unit: mm

Shaft dia.	Clearance	
	Radial direction	Axial direction
Incl. 50 mm	0.25 ~ 0.4	1 ~ 2
Over 50 mm	0.5 ~ 1	3 ~ 5

Contact type sealing method

In this type of sealing, the shaft is sealed by the application of pressure resulting from the elasticity of the seal material to the sealing surface of the shaft, which rotates, reciprocates or oscillates. Synthetic rubber, synthetic resin and felt are generally used as sealing materials.

① Oil seal
Synthetic rubber oil seals are the most general type of sealing used. The sealing effect is obtained when the elastic lip comes into contact with the shaft. Some lips are spring-loaded to maintain adequate pressing force. The sliding surfaces of the lip and the shaft always show frictional behavior such that the boundary lubrication and fluid lubrication are mixed. If there is an insufficient amount of oil between the contact surfaces, it will cause heat generation, wear and seizure. Conversely, if the oil film is too thick, it may cause oil leakage.

General oil seals are specified in JIS B 2402-1~5. IKO Oil Seals for Needle Roller Bearings (See page L1.) have a low sectional height to match the Needle Roller Bearings. Nitrile rubber is generally used as the material for oil seal lips. Table 32 shows the materials and their operating temperature ranges.

The finished surface of the shaft where the seal lip makes contact must have an appropriate surface roughness, as shown in Table 33, according to the peripheral speed. It must also have accurate circularity, and the shaft eccentricity should be less than 0.05 mm.

To increase wear resistance, the hardness of the sliding part of the shaft must be more than 40HRC. This can be achieved by hard-chrome plating or heat treatment.

Table 32 Seal materials and operating temperatures

Seal material		Operating temperature range °C
Synthetic rubber	Nitrile rubber	- 25 ~ + 120
	Acrylic rubber	- 15 ~ + 130
	Silicon rubber	- 50 ~ + 180
	Fluoro rubber	- 10 ~ + 180
Tetrafluoroethylene resin		- 50 ~ + 220

Table 33 Peripheral speed and surface roughness of shaft

Peripheral speed m / s		Surface roughness μmR_a (μmR_v)
Over	Incl.	
-	5	0.8(3.2)
5	10	0.4(1.6)
10	-	0.2(0.8)

② Felt seal
Because of their simple structure, felt seals have long been used to protect grease lubrication from dust. Since felt absorbs some grease during operation, it hardly causes heat generation and seizure, but it cannot be used when the peripheral speed of the shaft is high (more than 4 m/s). Where there is a high concentration of dirt and dust, they may become attached to the contact surface of felt, sometimes scratching the shaft surface. To prevent this, two felt seals are placed apart from each other, or a felt seal is used together with a synthetic rubber seal.



Purpose of lubrication

The main purpose of bearing lubrication is to reduce friction and wear and to prevent heat generation and seizure. The lubricant and the lubricating method have a big influence on the operating performance of the bearing, and it is therefore necessary to select them suitably for the operating conditions. The effects of lubrication are as follows.

1 Reduction of friction and wear

At the contact surfaces between the race rings, rolling elements and cage of the bearing, lubrication prevents metal-to-metal contact, and reduces friction and wear due to sliding and rolling, in the latter of which micro-slips occur by differential slip, skew, spin, or elastic deformation.

2 Elimination of frictional heat

The lubricant removes the heat generated by friction or transferred from outside, and prevents overheating of the bearing. Circulating lubrication is generally used for this purpose.

3 Influence on bearing life

The bearing life is extended if the rolling contact surfaces between the race rings and rolling elements are separated by an oil film of adequate thickness, and is shortened if the oil film is inadequate due to low oil viscosity, etc.

4 Rust prevention

The lubricant prevents rust formation on the inside and outside surfaces of the bearing.

5 Dust prevention

Grease lubrication is particularly effective for dust prevention. Oil circulating or jet lubrication is effective in washing foreign particles away from the area around the bearing.

Methods of lubrication

Grease lubrication and oil lubrication are generally used for rolling bearings. In special cases, solid lubricants are also used.

In general, grease lubrication requires the simplest sealing structure. It is therefore economical and widely used. Also, once filled with grease, the bearing can be used for a long period without replenishing the grease. However, compared with oil, its heat removal properties and cooling capacity are inferior, since grease has high flow resistance, which causes high churning heat.

Oil has greater fluidity and superior heat removal properties. It is therefore suitable for high-speed operations. In addition, it is simple to filter out dust and dirt from oil. Thus it can prevent the generation of noise and vibration and increase bearing life. Another advantage of oil lubrication is that it offers the possibility for selecting the appropriate method for particular operating conditions from among various available lubrication methods. However, measures to prevent oil leakage are required. As a guideline for selection, Table 34 compares grease and oil lubrication.

For the lubricants used for IKO Spherical Bushings, see page K8.

Table 34 Comparison between grease lubrication and oil lubrication

Item	Grease lubrication ⁽¹⁾	Oil lubrication
Sealing structure, Housing structure	Simple	Slightly complicated
Temperature	High temperature not allowed	High temperature allowed (Cooling effect by circulation)
Rotational speed	Low and medium speeds	High speed allowed
Load	Low and medium loads	High load allowed
Maintenance	Easy	Elaborate (Pay special attention to oil leaks.)
Lubricant replacement	Slightly complicated	Simple
Lubrication performance	Good	Very good
Dust filtration	Difficult	Simple
Entry of dust and dirt	Easy measures for protection	Dust and dirt can be removed by filtering in circulating lubrication.

Note⁽¹⁾ This represents bearing grease for general use.

Grease lubrication

1 Amount of grease to be filled

The amount of grease to be filled depends on the housing structure, dimensions, type of grease used and atmosphere. Generally, filling about 1/3 to 1/2 of the free space inside of the bearing and the housing is considered to be appropriate. Too much will cause a rise in temperature, and care should be taken especially at high speed rotations.

In Fig. 19, several grease pockets are provided by the grease sectors on one side of the bearing. Even if the filled grease is dispersed by the centrifugal force at high rotational speeds, it is trapped by the grease pockets and diverted back into the bearing again. Old grease accumulates in the space on the opposite side of the bearing, and this can be removed periodically by taking off the cover.

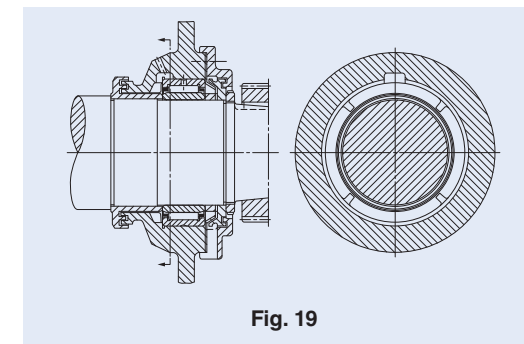


Fig. 19

2 Replenishment of grease

The life of grease depends on its type and quality, the type and dimensions of the bearing, operating conditions, temperature, amount of wear, penetration of foreign particles and water, etc.

Fig. 20 shows the grease replenishment intervals as a general guideline. The values obtained from this diagram apply under normal load conditions when the machine body is stationary and forces such as inertia are not acting on it, and the operating temperature on the outer surface of the bearing outer ring is less than +70°C. If the temperature exceeds +70°C, as a general rule, the replenishment interval is halved for every 15°C increase.

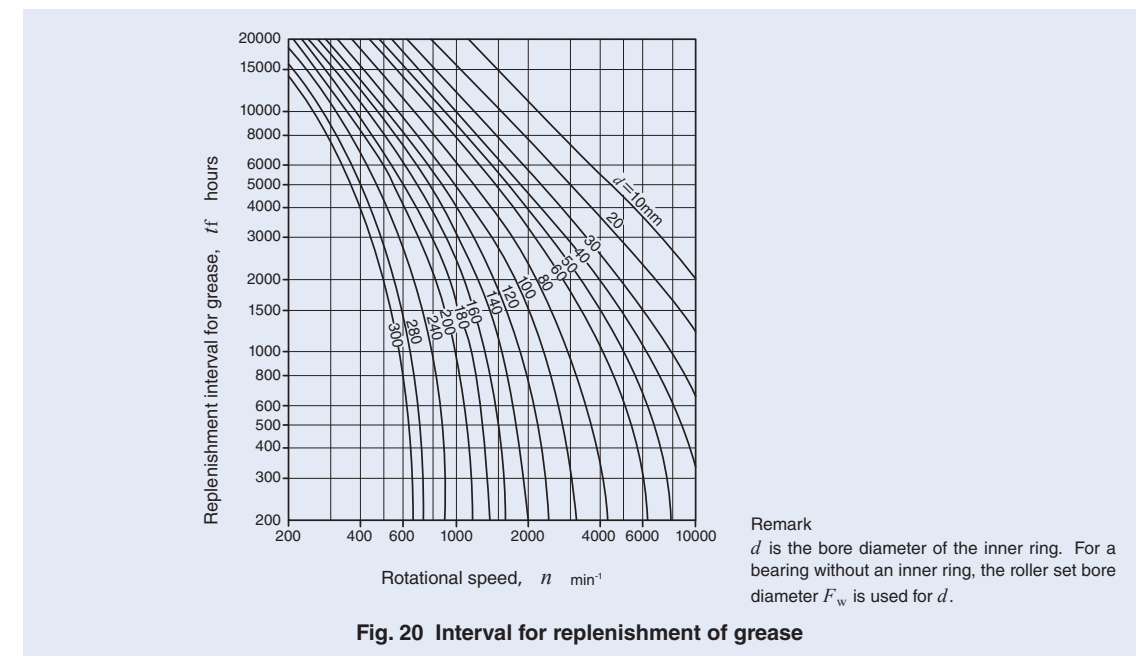


Fig. 20 Interval for replenishment of grease

Remark
d is the bore diameter of the inner ring. For a bearing without an inner ring, the roller set bore diameter F_w is used for d.

Oil lubrication

1 Oil bath lubrication

This is the most commonly used oil lubrication method, and is used for medium and low speeds. If the amount of oil is too large, heat will be generated by churning, and if the amount is too small, seizure will occur. Therefore, the correct amount of oil must be maintained. When the machine is stationary, the correct oil level in the case of a bearing mounted on a horizontal shaft, is near the center of the lowest rolling element. In the case of a vertical shaft, about 50% of the surfaces of the rolling elements should be submerged in oil.

It is desirable to provide an oil gauge so that the oil level can be easily checked while the machine is stationary or running.

2 Oil drip lubrication

Oil drips, which are fed down from a sight-feed oiler or along a fiber string, become an oil spray due to wind pressure generated by the rotating cage, shaft, nut, etc., or they strike the rotating parts and form an oil spray, which fills up the housing and every required part. Because oil spray removes frictional heat, this method has a more effective cooling effect than the oil bath method, and is widely used for high-speed rotation and medium load conditions.

In the case of the sight-feed oiler (Fig. 21), the number of drips can be adjusted. However, this is difficult using the string-feed method. The number of drips depends on the bearing type, rotational speed, etc., but 5 ~ 6 drips per minute is generally used.

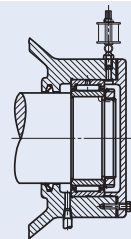


Fig. 21 Oil drip lubrication

3 Oil splash lubrication

In this method, oil is splashed in all directions by the rotation of the gear or disk. This can be used for considerably high-speed rotations without soaking the bearing directly in oil.

In the gear case where shafts and bearings are lubricated with the same oil, wear particles may be introduced into the bearing as they might get mixed with the oil. In this case, a permanent magnet is provided at the bottom of the gear case to collect metal particles, or a shield plate is installed next to the bearing.

Fig. 22 shows another method in which the splashed

oil flows along the grooves in the case and accumulates in the oil pockets, keeping the oil level constant. So the oil is steadily supplied to the bearing.

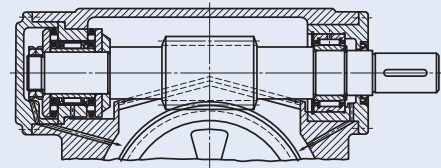


Fig. 22 Oil splash lubrication

4 Oil circulating lubrication

When automatic lubrication is more economical because lubrication is required at many points, or when cooling is required for high rotational speed, this method is used. The oil is supplied with a pump, which can control the oil pressure, and a filter or cooler, etc. can be set up in the circulation system, making this an ideal method of lubrication. As shown in Fig. 23, the oil supply and discharge ports are located opposite to each other, and the discharge port is made large to prevent the accumulation of oil.

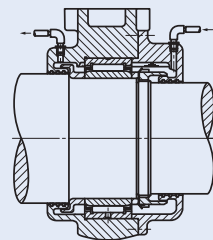


Fig. 23 Oil circulating lubrication

5 Oil mist lubrication

After dirt and dust are removed by a filter, the oil is turned into a spray by dry compressed air, and this lubricates the bearing. When the air and oil pass through the bearing, the air cools the bearing and the oil lubricates it. In addition, because the air inside the housing is at a higher pressure than the outside air, the entry of water and foreign particles is prevented. There are many other advantages of this method, and it is suitable for high rotational speed applications such as high speed internal grinding spindles.

6 Oil jet lubrication

This is a highly reliable lubrication method and is used under severe conditions such as ultra-high rotational speeds and high temperatures. The speed of the oil jet should be more than 20% of the peripheral speed of the inner ring raceway surface, since the air around

the bearing rotates together with the bearing forming an air wall. As shown in Fig. 24, the jet from the nozzle blows directly into the space between the inner ring and the cage. Due to the large amount of oil being used, it is more effective to make the discharge port larger, and use the forced discharge.

When the $d_m n$ value (mean value of the bearing outside and bore diameters in millimeter x rotational speed in min^{-1}) is more than 1,000,000, the speed of the jet should be 10 ~ 20 m/s, the nozzle diameter should be about 1 mm, oil supply pressure should be 0.1 ~ 0.5 MPa, and the oil supply amount should be about 500 cc/min or greater. When the rotational speed is higher, the oil supply pressure and the oil amount should be higher.

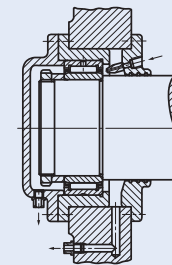


Fig. 24 Oil jet lubrication

Lubricants

For rolling bearings, lubricating grease or oil is generally used. For special applications, solid lubricants are used.

Lubricating grease

Grease is a semi-solid lubricant made by mixing base oil (liquid lubricant) and a thickener under heat and adding additives as required.

There are many types of grease according to various combinations of base oil, thickeners and additives. Grease is usually classified by thickeners and base oil. Table 35 shows the general properties of each type of grease.

Reference examples of the lubricant grece brand and performance are shown on page M46.

Table 35 Properties of various types of grease

Name (Common name)	Calcium grease	Sodium grease	Aluminum grease	Mixed base grease	Barium grease	Lithium grease			Non-soap base grease (Non-soap grease)		
	(Cup grease)	(Fiber grease)	(Mobile grease)			(Diester grease)	(Silicon grease)	(Bentone grease)			
Base oil	Mineral oil	Mineral oil	Mineral oil	Mineral oil	Mineral oil	Mineral oil	Diester oil	Silicon oil	Mineral oil	Synthetic oil	
Thickener	Ca soap	Na soap	Al soap	Na + Ca soap, Li + Ca soap	Ba soap	Li soap	Li soap	Li soap	Bentone	Silica gel, Polyurea, etc.	
Appearance	Buttery	Fibrous and buttery	Stringy and buttery	Fibrous and buttery	Fibrous and buttery	Buttery	Buttery	Buttery	Buttery	Buttery	
Pour point °C	80 ~ 90	150 ~ 180	70 ~ 90	160 ~ 190	150 ~ 180	170 ~ 190	170 ~ 190	200 ~ 250	200 ~	None	
Operating temperature range °C	-10 ~ +70	-20 ~ +120	-10 ~ +80	-10 ~ +100	-10 ~ +135	-20 ~ +120	-50 ~ +120	-50 ~ +180	-10 ~ +150	~ +200	
Pressure resistance	Strong to weak	Strong to medium	Strong	Strong	Strong to medium	Medium	Medium	Weak	Medium to weak	Medium	
Water resistance	Good	Poor	Good	Good, poor for Na+Ca soap grease	Good	Good	Good	Good	Good	Good	
Mechanical stability	Fair	Good	Poor	Good	Poor	Excellent	Excellent	Excellent	Good	Good to poor	
Features and application	Contains about 1% water. When the temperature rises to more than +80°C, the water evaporates and the grease separates into oil and soap. This is used for medium loads.	Long fibrous grease cannot withstand high speeds, but has good pressure resistance properties. Short fibrous grease is comparatively good for high speeds.	It has water and rust resistant properties, and adheres easily to metal surface.	Usable at fairly high speeds.	It has water and heat resistant properties. This is an all-purpose grease.	This is the best all-purpose grease among soap based greases.	Excellent under low temperature conditions and has superior frictional properties. Suitable for small bearings used in measuring instruments.	Mainly used for high temperatures. Not suited to high speeds and heavy loads.	Generally good heat resistance. Grease having a mineral base oil is for general use. Grease having a synthetic base oil is suitable for special use where superior heat and chemical resistance properties are required.		

1 Base oil

Petroleum lubricating oil is usually used as the base oil.

As the lubricating performance of grease depends mainly on that of base oil, the viscosity of the base oil is an important property. In general, low viscosity is suitable for light-load and high-speed rotations, and high viscosity for heavy-load and low-speed rotations. Synthetic lubricants of the diester or silicon series are used instead of lubricants of the petroleum series in consideration of the pour point and high temperature stability.

2 Thickener

As shown in Table 35, metal soap bases are mostly used as thickeners. In particular, Na-soap is water-soluble and emulsifies easily, and it cannot be used in damp or wet areas. The type of thickener and the pour point of grease have a close relationship. In general, the higher the pour point, the higher the maximum usable temperature of grease. However, even when the grease uses a thickener having a high pour point, its upper operating temperature limit is low if its base oil has low heat resistance.

3 Consistency

This represents the hardness grade of grease. Grease becomes harder in proportion to the amount of thickener if the same thickener is used. Immediately after grease has been stirred (usually 60 times), a depression is formed in the grease in a specified time using a specified cone. The consistency (combined consistency) is expressed by the value of depth of depression (mm) multiplied by 10. This value gives an estimate of the fluidity during operation with a greater value for softer grease. Table 36 shows the consistency number of grease and the relationship between the consistency and operating conditions.

Table 36 Consistency and operating conditions of grease

NLGI consistency number	Combined consistency	Application
0	385 ~ 355	For centralized lubrication,
1	340 ~ 310	For oscillating motion
2	295 ~ 265	For general use
3	250 ~ 220	For general use, For high temperature
4	205 ~ 175	For sealing with grease

4 Additives

Additives include various types of substances, which are added to grease in small quantities to improve its characteristics. For example, when a bearing is kept

running for long periods of time, its temperature rises. This results in oxidation of the lubricant and formation of oxides, which lead to corrosion of the bearing. Thus, when a bearing is to be operated for long periods of time without regreasing, antioxidants are added. In addition, grease containing extreme pressure additives is suitable for use in places that are subjected to heavy loads.

5 Miscibility of different greases

In principle, it is desirable to use grease of the same brand. However, when the mixing of different greases is unavoidable, greases with the same type of thickener and with a similar type of base oil should be used.

It should be noted that if different types of grease are mixed, they may interact with each other and the consistency will become softer than that for the individual greases.

Lubricating oil

For rolling bearings, refined mineral oil or synthetic oil is used. To improve its properties, antioxidant additives, extreme pressure additives and detergent additives are added as required.

When selecting lubricating oil, it is important to select oil which has adequate viscosity under operating temperatures. If the viscosity is too low, the formation of the oil film will be insufficient, causing abnormal wear and seizure. On the other hand, if the viscosity is too high, it will generate excessive heat or increase power loss due to viscous resistance. As a general standard, oil having higher viscosity should be used for heavier loads and oil having lower viscosity should be used for higher rotational speeds.

Under conditions of normal use for various bearings, the values of viscosity shown in Table 37 will be a guideline.

The relationship between viscosity and temperature can be obtained from Fig. 25. Also, Table 38 shows examples of selecting lubricating oil according to the conditions of bearing use.

Table 37 Bearing series and required viscosity of lubricating oil

Bearing series	Kinematic viscosity at operating temperatures
Needle roller bearings Roller bearings	13 mm ² /s or more
Crossed roller bearings	20 mm ² /s or more
Thrust needle roller bearings Thrust roller bearings	32 mm ² /s or more

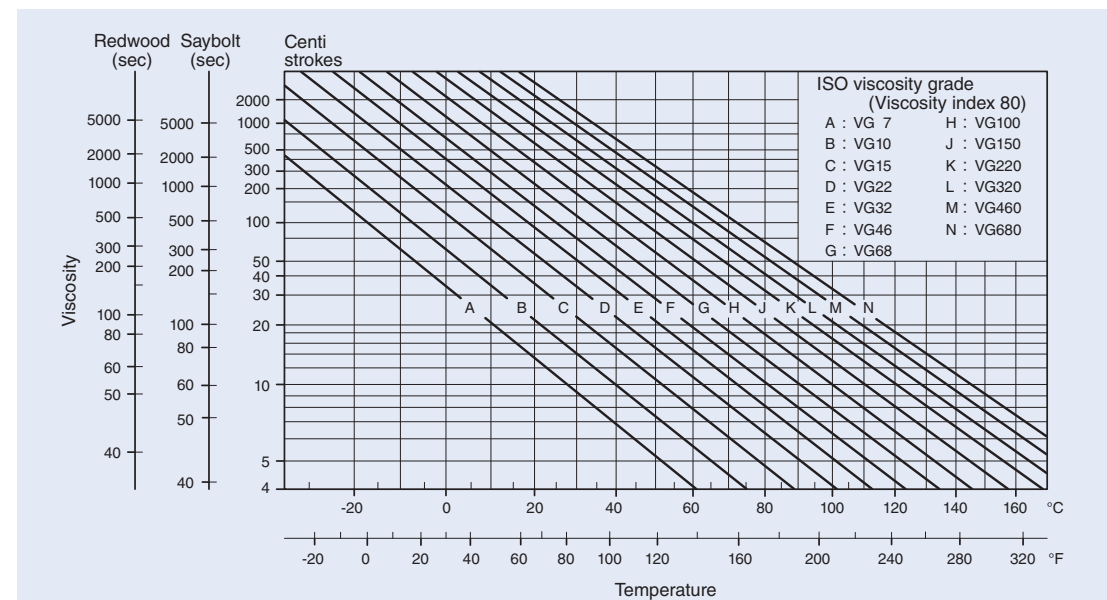


Fig. 25 Relationship between viscosity and temperature of lubricating oil

Table 38 Conditions of bearing use and examples of lubricating oil selection

Conditions	ISO viscosity grade(VG)												
	10	15	22	32	46	68	100	150	220	320	460	680	
Operating temperature	-30 ~ 0°C	← Refrigerator oil →											
	0 ~ 50°C	← Bearing oil →											
	50 ~ 80°C	← Turbine oil →											
	80 ~ 110°C	← Bearing oil →											
$d_m n$ value Load	Large	← Small →											
	Small	← Large →											

Remarks · Lubricating oils are based on JIS K 2211 (Refrigerating machine oils), JIS K 2239 (Bearing Oil), JIS K 2213 (Turbine Oil), and JIS K 2219 (Gear Oil).
 · The method of lubrication in these cases is mainly oil bath lubrication or circulating lubrication.
 · When the temperature is on the high side within the operating temperature range, oils of high viscosity are used.
 · $d_m n$ represents the mean value of the bore and outside diameters (mm) of the bearing multiplied by the rotational speed (min⁻¹).



C-Lube Bearing

IKO C-Lube Bearing is a bearing that is lubricated with a newly developed thermosetting solid-type lubricant. A large amount of lubricating oil and fine particles of ultra high molecular weight polyolefin resin are solidified by heat treatment to fill the inner space of the bearing. As the bearing rotates, the lubricating oil oozes out onto the raceway in proper quantities, maintaining the lubrication performance for a long period of time.

The dimension tables for C-Lube Machined Type Needle Roller Bearings, C-Lube Cam Followers, and C-Lube Roller Followers are shown on pages D77, I55, and I101.

C-Lube Bearing is available in all Needle Roller Bearing series. Also C-Lube Bearings for food processing are available, using NSF H1-certified lubrication oil and resin compliant with FDA standards to mitigate any effect on human health. If needed, please contact IKO.

Features of C-Lube Bearing

- Most suitable for preventing grease dry-up in applications where lubrication is difficult.
- Great reduction of maintenance work by extending the lubrication interval.
- Elimination of oil contamination, making this bearing most suitable for applications that would be adversely affected by oil.

Cautions for using C-Lube Bearing

- Never wash C-Lube Bearing with organic solvent and/or white kerosene which have the ability to remove fat, or leave the bearing in contact with these agents.
- The operating temperature range is -15 ~ +80°C. For continuous operation, the recommended operating temperature is +60°C or less.

- To ensure normal rotation of the bearing, apply a load of 1% or more of the basic dynamic load rating at use.
- The allowable rotational speed is different from that of the general needle roller bearings. For $d_m n$, $d_1 n$, and dn , use the values in Table 39 or less as guidelines.

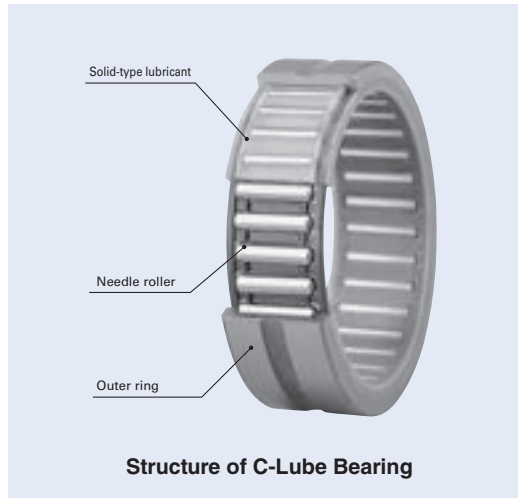


Table 39 C-Lube Bearing $d_m n$, $d_1 n$, dn

Representative model	Main model code	Allowable rotational speed
		$d_m n$ ⁽¹⁾ , $d_1 n$ ⁽²⁾ , dn ⁽³⁾
C-Lube Machined Type Needle Roller Bearings	TAF···/SG	$d_m n=20\ 000$
C-Lube Cam Followers	CF···/SG	$d_1 n=10\ 000$
C-Lube Roller Followers ⁽⁴⁾	NART···/SG	$dn=8\ 000$

- Notes⁽¹⁾ $d_m n = (\text{bore diameter of bearing [mm]} + \text{outside diameter of bearing [mm]}) / 2 \times \text{rotational speed [min}^{-1}]$
⁽²⁾ $d_1 n = \text{stud diameter [mm]} \times \text{rotational speed [min}^{-1}]$
⁽³⁾ $dn = \text{inner ring bore diameter [mm]} \times \text{rotational speed [min}^{-1}]$
⁽⁴⁾ The allowable rotational speed of C-Lube Roller Followers is applicable to use with oscillating rotation. For use with one-way or continuous rotation, please consult IKO.

Friction and Allowable Rotational Speed

Friction

Compared with sliding bearings, the starting (static) friction for rolling bearings is small, and the difference between the starting (static) friction and the kinetic friction is also small. The loss of power and temperature rise in machines are thus reduced, improving the mechanical efficiency.

Frictional torque is influenced by the bearing type, bearing load, rotational speed, lubricant characteristics, etc. It varies according to the lubricant when operated under light-loads and high-speed conditions, and according to the load when operated under heavy-loads and low-speed conditions.

Frictional torque of rolling bearings is complicated because it is influenced by various factors, but for convenience, it can be expressed approximately by the following equations.

· Radial bearings $M = \mu P \frac{d}{2}$ (37)

· Thrust bearings $M = \mu P \frac{d_m}{2}$ (38)

- where, M : Frictional torque, N-mm
 μ : Coefficient of friction
 P : Bearing load, N
 d : Bearing bore diameter, mm
 d_m : Mean value of bearing bore and outside diameters, mm

The approximate coefficients of friction of IKO Bearings under operating conditions, in which lubrication and mounting are correct and where loads are relatively large and stable, are shown in Table 40.

Table 40 Coefficient of friction

Bearing series	μ
Needle roller bearings with cage	0.0010 ~ 0.0030
Full complement needle roller bearings	0.0030 ~ 0.0050
Thrust needle roller bearings	0.0030 ~ 0.0040
Thrust roller bearings	0.0030 ~ 0.0040

Allowable rotational speed

As the rotational speed of rolling bearings is increased, the bearing temperature also increases due to the heat generated at the contact surfaces between the cage, raceways and rolling elements, until it finally leads to bearing seizure. It is therefore necessary to maintain the rotational speed of a bearing below a certain limit value to ensure safe operation for long periods. This limit value is called the allowable rotational speed.

Since the amount of heat generated is approximately proportional to the sliding speed at the contact area, this sliding speed is an approximate guide indicating the limit of the bearing rotational speed.

The allowable rotational speed of bearings thus varies according to the bearing type, size, bearing load, method of lubrication, radial clearance, and other such factors.

The allowable rotational speeds shown in the table of dimensions are empirical values. They are not absolute values and can be changed according to the bearing use conditions. Depending on the structure and accuracy around the bearing, the lubricant and the lubrication method, it is possible for some bearings to be operated at more than twice the allowable rotational speed given in the table without trouble.



Operating Temperature Range

The allowable operating temperature range for needle roller bearings is generally $-20 \sim +120^{\circ}\text{C}$.

When operating at temperatures outside this range, the operation may be limited by the allowable temperature range of prepacked grease, seal, cage material, etc. Further, if the bearing is used at high temperature, i.e. 120°C or above, the amount of dimensional displacement gets larger. So special heat treatment is necessary.

The operating temperature range for some types of bearings is different from the above. See the section for each bearing.

Handling of Bearings

Precautions in handling

Since the bearing is a high-accuracy mechanical element, special attention must be paid to its handling. The following precautions should be noted when handling the bearings.

① Bearings and their surrounding parts should be kept clean. Bearings and their surrounding parts must be kept clean paying special attention to dust and dirt. Tools and the working environment should also be cleaned.

② Bearings should be handled carefully. A shock load during handling may cause scratches, indentations and even cracks or chips on the raceway surfaces and rolling elements.

③ Bearings should be mounted or dismantled with proper tools. When mounting and dismantling, tools suitable for the bearing type should be used.

④ Bearings should be protected against corrosion. Bearings are treated with anti-corrosive oil. However, when handling them with bare hands, sweat from the hands may result in future rust formation. Gloves should be worn, or hands should be dipped in mineral oil.

⑤ Precautions regarding oil components. Rust prevention oil or grease is used for bearings. Therefore, oil may drip or spatter depending on the operating conditions. Consider installing a shielding plate if necessary.

Storage

Store bearings laid flat indoors, placed in the packing/ packaging provided by IKO. Avoid storing in high temperatures, low temperatures, and high humidity. In products pre-packed with lubricant, the lubricant will deteriorate with age if products are stored for a long time. Be sure to reapply lubricant before use.

Mounting

Preparation

Before mounting the bearing, the dimensions and fillets of the shaft and housing should be checked to ensure that they conform to specifications.

Bearings should be unwrapped just before mounting. In case of grease lubrication, bearings should be filled with grease without cleaning the bearings. Even in the case of oil lubrication, it is normally unnecessary to clean the bearings. However, when high accuracy is required or when using at high speeds, the bearings should be cleaned using cleaning oil to remove thoroughly oily contents. The cleaned bearings should not be left alone without anti-corrosive precautions, because bearings can easily be corroded after anti-corrosive agents are removed.

Lubricating grease is prepacked in some types of bearings. Therefore, refer to the relevant section for each bearing.

Methods of mounting

Mounting methods of bearings are different according to the type of bearing and the fit. In general, mounting of needle roller bearings is comparatively easy. However, non-separable bearings with large interferences should be handled with great care.

① Mounting by press fit

Small and medium bearings with small interferences require a small pressing-in force for mounting, and they are mounted using a press at room temperature. The bearing should be pressed in carefully, applying a force evenly to the bearing with a fitting tool as shown in Fig. 26. For separable bearings, the inner and outer rings can be mounted separately, and the mounting work is simple. However, when installing the shaft and inner ring assembly into the outer ring, care should be taken not to damage the raceway surfaces and rolling elements.

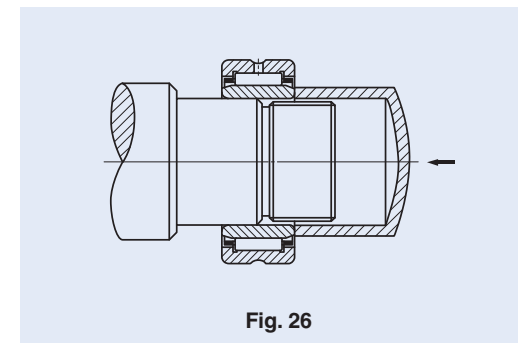


Fig. 26

When mounting non-separable bearings, the inner and outer rings are pressed in simultaneously by applying a cover plate as shown in Fig. 27. It must never happen that the inner ring is press-fitted to the shaft by striking the outer ring, or the outer ring by striking the inner ring, because the raceway surfaces and rolling elements will be scratched or indented.

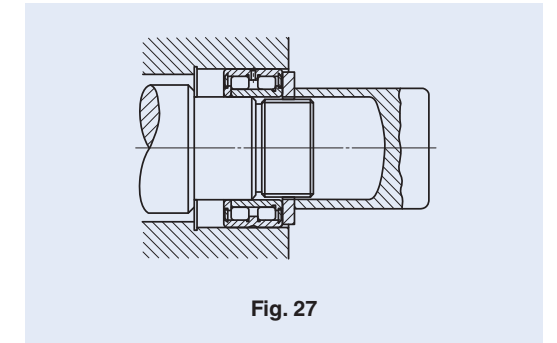


Fig. 27

When press fitting, the friction of the fitting surfaces can be reduced by applying high viscosity oil over the fitting surfaces.

The pressing-in or pulling-out force to be applied to the bearing is given on page A59.

② Mounting by shrink fitting

This method is used when the interference is great or when a large bearing is to be fitted. The housing is heated and thermally expanded when fitting the outer ring to the housing and the inner ring is heated and expanded when fitting it to the shaft allowing the bearing to be set easily within a short time. The maximum allowable temperature for the shrink fit is $+120^{\circ}\text{C}$, and heating should be performed appropriately. Pure non-corrosive mineral oil is recommended as the heating oil for shrink fit, and insulation oil for transformers is considered to be the best. During cooling, the bearing also shrinks in the axial direction. Therefore, to ensure that there is no clearance between the bearing and the shoulder, an axial force must be applied continuously to the bearing until it has cooled.

When the interference between the outer ring and the housing is great, an expansion fit method in which the bearing is cooled using dry ice or other cooling agent before fitting can be used. Immediately after fitting, however, moisture from the air easily condenses on the bearing. Therefore, it is necessary to take preventive measures against corrosion.

Pressing force and pulling force

Guidelines for the pressing force when pressing in the inner ring to the shaft and the pulling force when pulling it out are obtained from the following equation.

$$K = f_k \frac{d}{d+2} \Delta_{df} B \left\{ 1 - \left(\frac{d}{F} \right)^2 \right\} \dots\dots\dots(39)$$

- where, K : Pressing or pulling force, N
- f_k : Resistance factor determined by the coefficient of friction
- When pressing in inner ring to shaft, $f_k=4 \times 10^4$
- When pulling out inner ring from shaft, $f_k=6 \times 10^4$
- d : Bore diameter of inner ring, mm
- Δ_{df} : Apparent interference, mm
- B : Width of inner ring, mm
- F : Outside diameter of inner ring, mm

The actual pressing force or pulling force may be greater than the calculated value due to mounting errors. When designing a puller, it is necessary that the puller has the strength (rigidity) to withstand more than 5 times the calculated value.

Running test

After mounting the bearing, a running test is carried out to check whether the mounting is normal. Usually, it is first checked by manual turning. Then, it is operated by power gradually from no-load and low-speed up to normal operating conditions to check for abnormalities.

Noise can be checked by using a soundscope or similar instrument. In this test, checks are carried out for the following abnormalities.

- 1 Manual turning**
 - (a) Uneven torque Improper mounting
 - (b) Sticking and rattling ... Scratches or indentations on the raceway surface
 - (c) Irregular noise ... Penetration of dust or foreign particles
- 2 Power running**
 - (a) Abnormal noise or vibration ... Indentations on the raceway surface, too great clearance
 - (b) Abnormal temperature ... Unsuitable lubricant, improper mounting, too small clearance

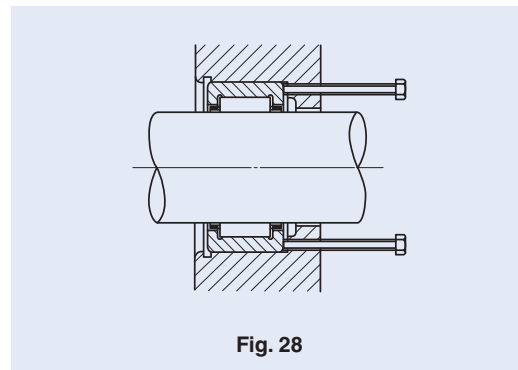
Dismounting

Dismounting of the bearings is carried out for the periodic inspection or repairs of machines. By inspecting the bearing, related parts or mechanisms, lubrication, etc., important data is obtained. In the same manner as in mounting, care should be taken to prevent damage to the bearing or other parts.

A suitable dismounting method should be selected according to the type of the bearing, fit, etc. Bearings mounted by interference fit are especially difficult to dismount, and it is necessary to give due consideration to the structure around the bearing during the design stage.

Dismounting of outer ring

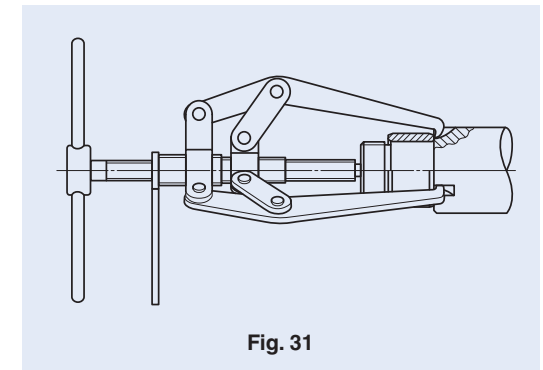
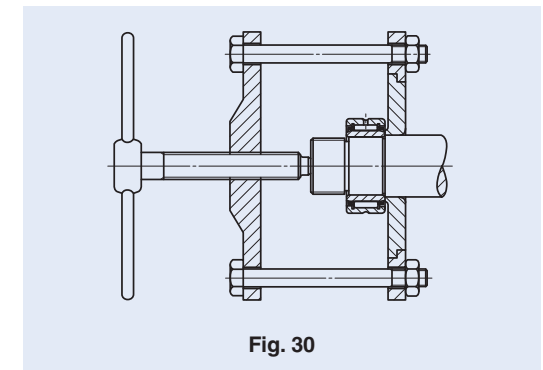
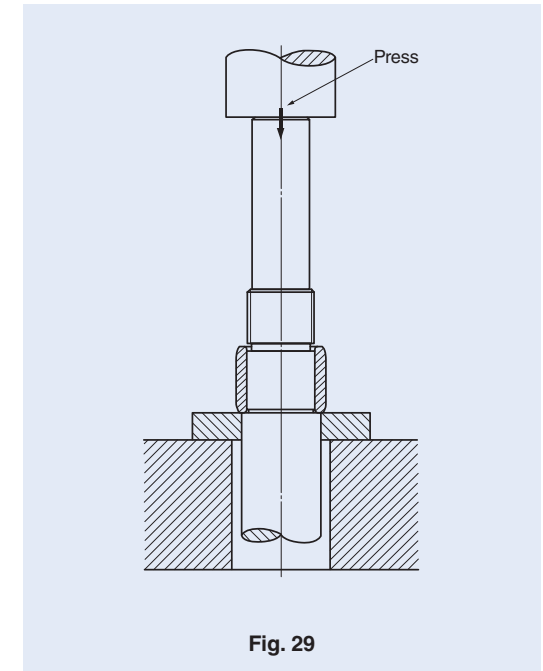
Outer rings mounted by interference fit are dismounted as shown in Fig. 28, by screwing in the push-out bolts evenly through several screw holes provided at places corresponding to the side face of the outer ring.



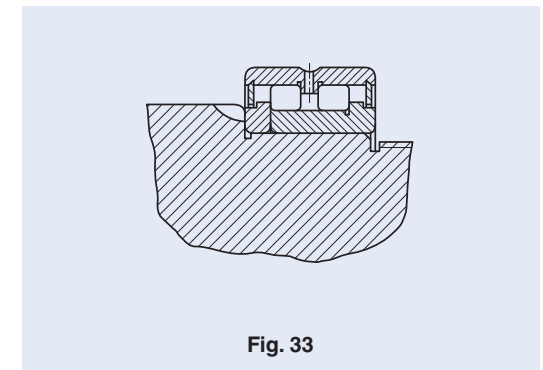
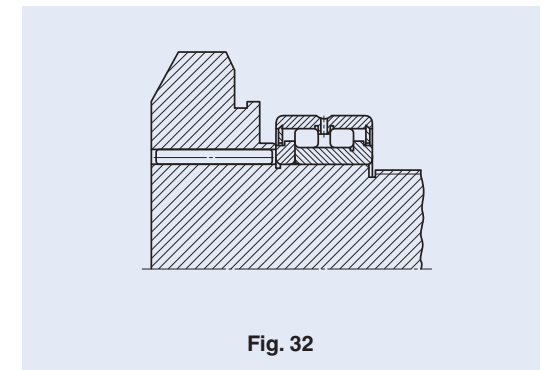
Dismounting of inner ring

In the case of bearings such as needle roller bearings in which the inner and outer rings are separable, the simplest way to press out the inner ring is by using a press as shown in Fig. 29.

The puller shown in Fig. 30 is also generally used. This is designed according to the bearing size. In addition, there are a 3-hook puller (Fig. 31) and a 2-hook puller for wide-range use.



In addition to these, when it is difficult to remove the inner ring due to high shoulders, several holes for removal pins are made through the shoulder, or several hook grooves are cut in the shoulder as shown in Fig. 32 and Fig. 33. When a bearing is not to be used again after removal, it may be removed by heating with a torch lamp.



- A
- B
- C
- D
- E
- F
- G
- H
- I
- J
- K
- L
- M

Inspection of bearing

Cleaning of bearing

When inspecting a bearing after removal, the appearance of the bearing should be recorded first. Then, after the residual amount of lubricant is checked and a sample of lubricant is collected, the bearing should be cleaned.

For cleaning, light oil or kerosene is commonly used. Cleaning is divided into rough cleaning and final cleaning, and wire gauze is set as a raised bottom in a container to prevent the bearing from touching the bottom of the container.

Lubricating grease and adhering substances such as foreign particles are removed with a brush, etc., using oil for rough cleaning. Care should be taken during this process, because if the bearing is turned with foreign particles attached, the raceway surfaces may be scratched.

Final cleaning is carried out by turning the bearing in cleaning oil. It is desirable that the cleaning oil is kept clean by filtering. Immediately after cleaning, the bearing must be protected against corrosion.

Inspection and evaluation of bearing

The judgement as to whether the removed bearing is reusable depends on the inspection after cleaning. Conditions of the raceway surfaces, rolling elements and fitting surfaces, wear condition of the cage, increase of bearing clearance, dimensions, rotational accuracy, etc. should be checked for damage and abnormalities.

The evaluation is performed based on the experience taking into consideration the degree of damage, machine performance, importance of the machine, operating conditions, period until the next inspection, and other such factors.

Maintenance and inspection

Maintenance and inspection

Maintenance and inspection are carried out to maintain good performance of bearings installed in the machine.

Maintenance is performed by checking the machine operating conditions, checking and replenishing or replacing the lubricant, checking the bearing and related parts by periodic disassembly and other such procedures.

Items for inspection of a running bearing in a machine include the bearing temperature, noise, vibration and condition of lubricant.

When any abnormality is found during operation, the cause should be investigated and measures taken by referring to the section on running test on page A59. When removing a bearing, refer to the section on dismounting on page A59.

Damage, causes and corrective action

Rolling bearings can generally be used fully up to their rolling fatigue life if they are properly selected, mounted, operated and maintained. However, they may actually be damaged earlier than their expected lifetimes creating problems or accidents. Common causes of damage include improper mounting or handling, insufficient lubrication and penetration of foreign particles.

It may be difficult to determine the exact cause of a problem by checking only the damaged bearing. The conditions of the machine before and after the occurrence of the damage, the location and the operating and ambient conditions of the bearing, the structure around the bearing, etc. should also be examined. It then becomes possible to assess the cause of the damage by linking the conditions of the damaged bearing to the probable causes arising from the machine operation, and to prevent the recurrence of similar problems.

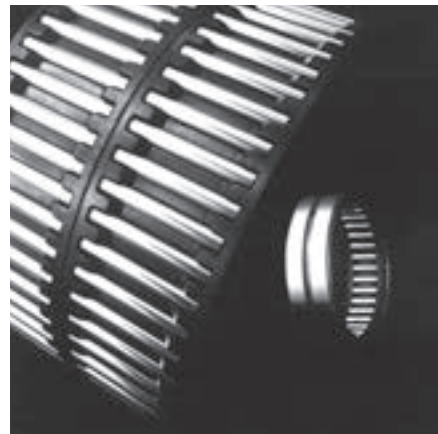
Common types of damage, causes and corrective action are listed in Table 41.

Table 41 Damage, causes and corrective action

Condition of bearing damage		Cause	Corrective action
Flaking	Flakings at opposite circumferential positions on raceway surfaces	Improper roundness of housing bore	Correction of housing bore accuracy
	Flakings in the vicinity of raceway surface edges and roller ends	Improper mounting, Shaft deflection, Poor centering, Poor accuracy of shaft or housing	Careful mounting, Careful centering, Correction of shoulders of shaft and housing for right angles
	Flakings on raceway surfaces with an interval corresponding to roller pitch	Great shock load when mounting, Rusting during machine stoppage	Careful mounting, Protection against rust for long periods of machine stoppage
	Early flaking on raceway surfaces and rolling elements	Too small clearance, Too great load, Poor lubrication, Rusting, etc.	Correct selection of fit and clearance Correct selection of lubricant
Galling	Galling on raceway surfaces and rolling surfaces of rollers	Poor lubrication in early stage Grease consistency too hard High acceleration at start	Selection of softer grease, Avoiding quick acceleration
	Galling between roller end faces and collar guide surfaces	Poor lubrication, Poor mounting, Large axial load	Correct selection of lubricant Correct mounting
Breakage	Cracks in outer or inner ring	Excessive shock load, Too much interference. Poor cylindricity of shaft. Too large fillet radius, Development of thermal cracks, Development of flaking	Reevaluation of load conditions, Correction of fit, Correction of machining accuracy of shaft or sleeve, Making fillet radius smaller than the chamfer dimension of bearing
	Cracked rolling elements, broken collar	Development of flaking Shock to collar when mounting, Dropped by careless handling	Careful handling and mounting
	Broken cage	Abnormal load to cage by poor mounting, Poor lubrication	Minimizing mounting errors, Study of lubricating method and lubricant
Dent	Indentations on raceway surfaces at an interval corresponding to the pitch between rolling elements (brinelling)	Shock load applied when mounting, Excessive load while stopping	Careful handling
	Indentation on raceway surfaces and rolling surfaces of rollers	Biting of foreign substances such as metal chips and sands	Cleaning of housing, Improvement of sealing, Use of clean lubricant
Abnormal wear	False brinelling (Phenomenon like brinelling)	Vibration when the bearing is stationary such as during transportation, Oscillating motion with small amplitude	Fixing of shaft and housing, Use of lubricating oil, Application of preload to reduce vibration
	Fretting Localized wear of fitted surfaces accompanied by red-brown wear particles	Sliding between fitted surfaces	Increase of interference, Application of oil
	Wear on raceway surfaces, collar surfaces, rolling surfaces of rollers, cages, etc.	Penetration of foreign particles, Poor lubrication, Rust	Improvement of sealing, Cleaning of housing Use of clean lubricant
	Creep Wear on fitted surfaces	Sliding between fitted surfaces, Insufficient tightening of sleeve	Increase of interference, Correct tightening of sleeve
Seizure	Discoloration of rolling elements and/or raceway surfaces and/or flange surfaces, Adhesion and welding, Discoloration of cage	Poor lubrication, Too small clearance, Poor mounting	Supply of proper amount of proper lubricant, Rechecking of fit and bearing clearance Rechecking of mounting dimensions and related parts
Electric corrosion	Ripples on raceway surfaces	Melting by sparks due to electric current	Insulation of bearing, Grounding to avoid electric current
Rust, corrosion	Rust or corrosion on bearing inside surfaces or on fitted surfaces	Condensation of vapor in air, Penetration of corrosive substances	Careful storage if under high temperature and high humidity, Protection against rust, Improvement of sealing



**Description of Each Series
&
Table of Dimensions**



Shell Type Needle Roller Bearings	TA·TLA·BA·BHA	B1
Needle Roller Cages for general usage	KT	C1
Needle Roller Cages for engine connecting rods	KT··EG·KTV··EG	C17
Machined Type Needle Roller Bearings	NA·TAFI·TRI·BRI	D1
C-Lube Machined Type Needle Roller Bearings	TAF··/SG	D75
Needle Roller Bearings with separable cage	NAF	D79
Roller Bearings	NAG·NAU·TRU·NAS	E1
Thrust Bearings	NTB·AS·AZK·WS·GS	F1
Combined Type Needle Roller Bearings	NAX·NBX·NATA·NATB	G1
Inner Rings	IRT·IRB·LRT·LRB	H1
Cam Followers	CF··B·CFKR·CFS·NUCF··B·CR	I1
C-Lube Cam Followers	CF··/SG	I55
Roller Followers	NAST·NART·NURT·CRY	I83
C-Lube Roller Followers	NART··/SG	I101
Crossed Roller Bearings	CRBHV·CRBFV·CRBC·CRB·CRBT·CRBTf·CRBS	J1
Spherical Bushings	SB·GE·SBB	K1
Pilloballs	PB·PHS·POS·PHSA	K29
L-balls	LHSA·LHS	K45
Super Flexible Nozzles	SNA·SNM·SNPT	K55
Parts For Needle Roller Bearings	OS·DS·WR·AR·Needle Roller	L1

SHELL TYPE NEEDLE ROLLER BEARINGS

- Shell Type Caged Needle Roller Bearings
- Shell Type Grease Retained Full Complement Needle Roller Bearings



Structure and features

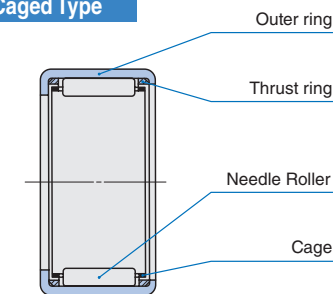
IKO Shell Type Needle Roller Bearings are light-weight bearings with large load ratings. They employ a shell type outer ring made from a thin special-steel plate which is accurately drawn, carburized and quenched, thus providing the lowest sectional height among the needle roller bearings.

There are two types of bearings available in this series; the caged type and the full complement type. The appropriate type can be selected according to the operating conditions. The caged type has a structure in which the needle rollers are accurately guided by the cage and thrust rings. It is useful for applications at high-speed rotation. The full complement type needle roller bearing, on the other hand, is suitable for heavy-load applications at low-speed rotation.

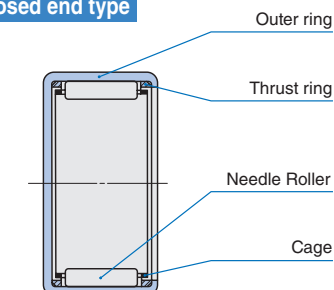
Since these bearings are press-fitted into the housing, no fixtures for axial positioning are needed. They are ideal for use in mass-produced articles that require economy, and have a wide variety of applications.

Structures of Shell Type Needle Roller Bearings

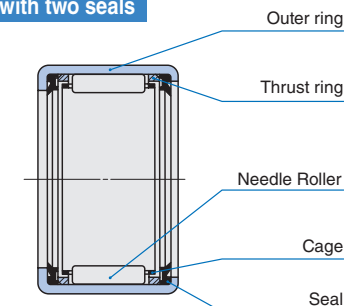
Standard Caged Type



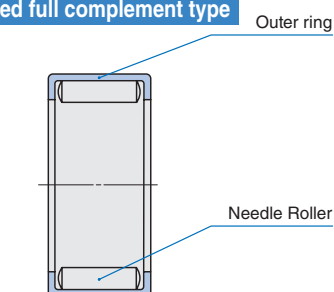
Caged and closed end type



Caged type with two seals



Grease retained full complement type



Types

Numerous varieties of Shell Type Needle Roller Bearings are available as shown in Table 1.

Table 1 Type of bearing

Series	Type	Caged			Full complement Grease retained
		Standard	Closed end	With seals (1)	
Metric series	—	TLA ... Z	TLAM	TLA ... UU	YTL
	Heavy duty	TA ... Z	TAM	—	YT
Inch series	—	BA ... Z	BAM	—	YB
	Heavy duty	BHA ... Z	BHAM	—	YBH

Note(1) When the heavy duty type with seals or the closed end type with one seal is required, please consult IKO.
 Remark A "W" is added to the model code to indicate that the rolling elements are of the double-row type.
 Example TAW 5045 Z

Shell Type Caged Needle Roller Bearings

Standard type

This type has a narrow gap between the bore of the marked-side flange of the outer ring (brand, bearing number, etc. are marked) and the shaft, which prevents grease leaks and the entry of foreign particles. This type has wide applications.

Closed end type

This type is completely closed on one side of the outer ring, and is ideal for use when perfect closing of shaft ends is desired. The shape of the closed end surface of the outer ring is divided into two types, and the dimensions t_1 and t_2 in the illustrations shown in the dimension tables apply to the bearings with the roller set bore diameters, $F_w > 22$ and $F_w \leq 22$, respectively.

Type with seals at both sides

This type has a wider outer ring than the standard type and is installed with seals consisting of a reinforcing ring and special synthetic rubber to prevent grease leaks and the entry of foreign particles.

Shell Type Grease Retained Full Complement Needle Roller Bearings

This type has full complement rollers which extend to the full width of the outer ring raceway. It can, therefore, withstand heavy bearing loads and is most suitable for low and medium rotational speeds as well as rocking motions. As lubricating grease is prepacked with the rollers, the bearing can be operated immediately after being fitted.

Identification Number

The identification number of Shell Type Needle Roller Bearings consists of a model code and dimensions. Examples of the arrangement are shown below. When using with inner rings, the assembled inner rings shown in the dimension tables are used. An example in this case is also shown below. Inner rings are delivered separately.

Examples of identification number

Example 1

Example 2 (With inner ring)

Accuracy

The outer rings of Shell Type Needle Roller Bearings are thin and therefore cannot avoid deformation due to heat treatment. It is thus not appropriate to take direct measurements of the bearing. The roller set bore diameter is measured using a plug gauge or tapered gauge after press-fitting the bearing to a suitable ring gauge. The gauge specifications are shown in Tables 2.1 and 2.2. Tolerances of outer ring width C are shown in Table 3.

Table 2.1 Measuring gauges for metric series bearings unit: mm

F_w Nominal roller set bore diameter	Ring gauge		Plug gauge	
	TA...Z(1)	TLA...Z(2)	Go	No-go
4	—	7.981	4.004	4.016
5	—	8.981	5.004	5.016
6	—	9.981	6.004	6.016
7	—	10.977	7.005	7.020
8	14.992	11.977	8.005	8.020
9	15.992	12.977	9.005	9.020
10	16.992	13.977	10.005	10.020
12	18.991	15.977(3) 17.977(3)	12.006	12.024
13	—	18.972	13.006	13.024
14	21.991	19.972	14.006	14.024
15	21.991	20.972	15.006	15.024
16	23.991	21.972	16.006	16.024
17	23.991	22.972	17.006	17.024
18	24.991	23.972	18.006	18.024
19	26.991	—	19.007	19.028
20	26.991(4) 27.991(4)	25.972	20.007	20.028
21	28.991	—	21.007	21.028
22	28.991(5) 29.991(5)	27.972	22.007	22.028
24	30.989(6) 31.989(6)	—	24.007	24.028
25	32.989	31.967	25.007	25.028
26	33.989	—	26.007	26.028
28	36.989	34.967	28.007	28.028
29	37.989	—	29.007	29.028
30	39.989	36.967	30.007	30.028
32	41.989	—	32.009	32.034
35	44.989	41.967	35.009	35.034
37	46.989	—	37.009	37.034
38	47.989	—	38.009	38.034
40	49.989	46.967	40.009	40.034
45	54.988	51.961	45.009	45.034
50	61.988	57.961	50.009	50.034
55	66.988	62.961	55.010	55.040
60	71.988	—	60.010	60.040
62	73.988	—	62.010	62.040
65	76.988	—	65.010	65.040
70	81.987	—	70.010	70.040

Notes(1) Also applicable to TAM and YT
 (2) Also applicable to TLAM, YTL, TLA...UU
 (3) The upper value is for TLA 1210Z model, and the lower value is for TLA 1212Z model.
 (4) The lower value is for TA 202820Z model, and the upper value is for models other than TA 202820Z model.
 (5) The lower value is for TA 223016Z and TA 223020Z models, and the upper value is for models other than those models.
 (6) The lower value is for TA 243216Z and TA 243220Z models, and the upper value is for models other than those models.

Table 2.2 Measuring gauges for inch series bearings unit: mm

F_w Nominal roller set bore diameter	Ring gauge		Plug gauge	
	BA...Z(1)	BHA...Z(2)	Go	No-go
3.969	7.155	—	3.990	4.016
4.762	8.730	—	4.783	4.808
6.350	11.125	—	6.388	6.414
7.938	12.713	14.300	7.976	8.001
9.525	14.300	15.888	9.563	9.588
11.112	15.888	17.475	11.151	11.176
12.700	17.475	19.063	12.738	12.764
14.288	19.063	20.650	14.326	14.351
15.875	20.650	22.238	15.913	15.938
17.462	22.238	23.825	17.501	17.526
19.050	25.387	26.975	19.063	19.088
20.638	26.975	28.562	20.650	20.676
22.225	28.562	30.150	22.238	22.263
23.812	30.150	—	23.825	23.851
25.400	31.737	33.325	25.413	25.438
26.988	33.325	—	27.000	27.026
28.575	34.912	38.087	28.588	28.613
30.162	38.087	—	30.175	30.201
31.750	38.087	41.262	31.763	31.788
33.338	41.262	—	33.350	33.378
34.925	41.262	44.437	34.938	34.966
38.100	47.612	—	38.113	38.143
41.275	50.787	—	41.288	41.318
44.450	53.962	57.137	44.463	44.496
47.625	57.137	—	47.638	47.671
50.800	60.312	—	50.815	50.848
52.388	—	64.280	52.413	52.451
53.975	63.487	—	53.990	54.028
57.150	66.662	—	57.165	57.203
66.675	76.187	—	66.700	66.738
69.850	79.362	—	69.875	69.914

Notes(1) Also applicable to BAM and YB
 (2) Also applicable to BHAM and YBH

Table 3 Tolerances of outer ring width C unit: mm

Series	Tolerance
Metric	0 ~ - 0.20
Inch	0 ~ - 0.25

Fit

As the outer ring is thin, the correct dimensions and accuracy of Shell Type Needle Roller Bearings are obtained only after they have been press-fitted into the housing bore. Bearing accuracy is directly affected by housing dimensions, shape and rigidity. This should be taken into account when considering fit and accuracy. The radial clearance after fitting the bearing to the shaft and the housing bore varies with their tolerances.

Table 4 shows the recommended fit for Shell Type Needle Roller Bearings.

Table 5 shows a calculation example of radial clearance after fitting. This calculation applies to bearings without inner ring to be fitted into rigid steel or cast iron housings. When the housing is made of light alloy or a thin steel pipe, it is necessary to check dimensions by actual measurement.

Generally, when making the radial clearance smaller, it is recommended that the shaft diameter be increased, without decreasing the housing bore diameter.

Table 4 Recommended fit

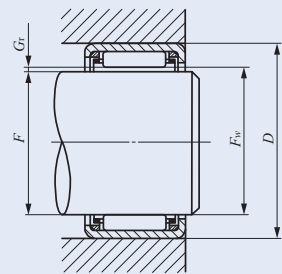
Type of bearing	Housing material	Tolerance class		
		Shaft (1)		Housing bore
		Without inner ring	With inner ring	
TA...Z, BA...Z, BHA...Z, TAM, BAM, BHAM, YT, YB, YBH	Steel Cast iron	h6	k5(j5)	J7
	Light alloy (Thin steel pipe)	h6	k5(j5)	M7(N7)
TLA...Z, TLAM, YTL, TLA...UU	Steel Cast iron	h6	k5(j5)	N7
	Light alloy (Thin steel pipe)	h6	k5(j5)	R7(S7)

Note(1) When housings are made of light alloy or a thin steel pipe, the roller set bore diameter is greatly affected by the housing thickness and shape. Therefore, before mass-production assembly, assembly tests should be carried out to confirm the amount of dimensional change and to determine the tolerance of the shaft which will give normal clearances.

Table 5 Calculation example of radial clearance after fitting

unit: mm

Calculation procedure	Example of TLA 2020 Z
<ol style="list-style-type: none"> Dimension of roller set bore diameter of bearing after it has been press-fitted into the ring gauge. Dimension of ring gauge (D_0): See Tables 2.1 and 2.2 on page B4. Max. value of roller set bore dia. ($F_{w\max}$): No-go dimension of plug gauge Min. value of roller set bore dia. ($F_{w\min}$): Go dimension of plug gauge 	From Table 2.1 on page B4 $D_0 = 25.972$ $F_{w\max} = 20.028$ $F_{w\min} = 20.007$
<ol style="list-style-type: none"> Dimension of housing bore Max. value of housing bore (D_{\max}): See the dimension table. Min. value of housing bore (D_{\min}): See the dimension table. 	From the dimension table on page B14, $D_{\max} = 25.993$ $D_{\min} = 25.972$
<ol style="list-style-type: none"> Dimension of roller set bore diameter of bearing after it has been press-fitted into the housing bore Max. value of roller set bore dia. ($F_{we\max}$) = $(D_{\max} - D_0) + F_{w\max}$ Min. value of roller set bore dia. ($F_{we\min}$) = $(D_{\min} - D_0) + F_{w\min}$ 	From the equations, $F_{we\max} = 20.049$ $F_{we\min} = 20.007$
<ol style="list-style-type: none"> Dimension of shaft Max. value of shaft dia. (F_{\max}): See the dimension table. Min. value of shaft dia. (F_{\min}): See the dimension table. 	From the dimension table on page B14, $F_{\max} = 20.000$ $F_{\min} = 19.987$
<ol style="list-style-type: none"> Radial clearance after mounting Max. value of radial clearance ($G_{r\max}$) = $F_{we\max} - F_{\min}$ Min. value of radial clearance ($G_{r\min}$) = $F_{we\min} - F_{\max}$ 	From the equations, $G_{r\max} = 0.062$ $G_{r\min} = 0.007$ The radial clearance after mounting becomes 0.007~0.062 mm.



D : Housing bore diameter
 F_w : Roller set bore diameter
 F : Shaft diameter
 G_r : Radial clearance

Lubrication

Bearings with prepacked grease are shown in Table 6. ALVANIA GREASE S2 (Shell Lubricants Japan K.K.) is prepacked as the lubricating grease.

In the case of bearings without prepacked grease, perform proper lubrication for use. If the bearings are operated without lubrication, the wear of the roller contact surfaces will increase and the bearing life will be shortened.

Oil Hole

For Shell Type Needle Roller Bearings with an oil hole, "OH" is appended to the end of the identification number.

Example TA 2525 Z OH
 The symbol "OH" is not marked on the bearing itself, but is shown on its packaging, etc. When bearings with multiple oil holes are required, please consult IKO.

Table 6 Bearings with prepacked grease

○ : With prepacked grease × : Without prepacked grease

Series	Bearing type	Caged			Full complement
		Standard	Closed end	With seals	Grease retained
Metric series	TLA, TLAM, YTL	×	×	○	○
	TA, TAM, YT	×	×	—	○
Inch series	BA, BAM, YB	×	×	—	○
	BHA, BHAM, YBH	×	×	—	○

Static Safety Factor

Since Shell Type Needle Roller Bearings employ an outer ring made from a thin steel plate which is drawn, carburized and quenched, excessively large loads must be avoided. The required static safety factor is usually more than 3.

Specifications of shaft and housing

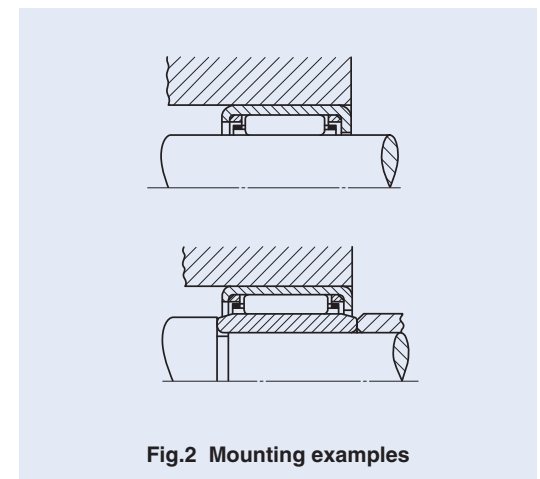
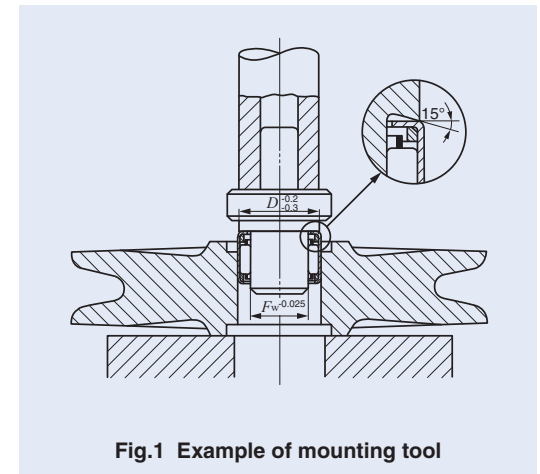
Shell Type Needle Roller Bearings are commonly used without an inner ring. In such cases, the surface hardness of the raceway surface should be 58 ~ 64HRC and the surface roughness should not exceed $0.2 \mu mR_a$. However, when the operating condition is not severe, a surface roughness $0.8 \mu mR_a$ or less can be used.

If the surface hardness is low, the load rating must be corrected by the hardness factor shown on page A20. When the shaft cannot be heat treated and finished by grinding, the use of IKO Inner Rings for Shell Type Needle Roller Bearings (See page H1.) is recommended.

Mounting

Shell Type Needle Roller Bearings should be pressed into the housings gently using the appropriate tool as shown in Fig. 1, with their marked end surface up. As the outer ring is thin, it must never be struck directly with a hammer.

Since the outer rings of Shell Type Needle Roller Bearings are firmly fitted to housing bores with interference, it is unnecessary to fix them axially. Fig. 2 shows mounting examples.



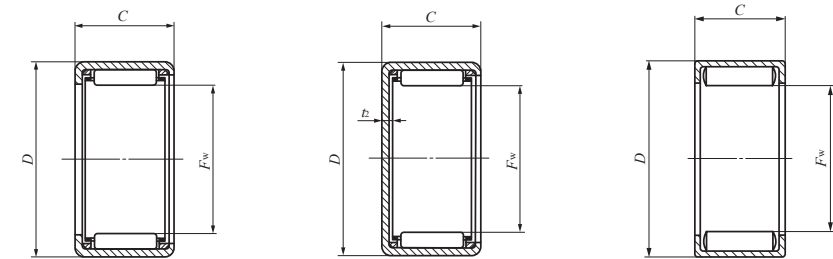
SHELL TYPE NEEDLE ROLLER BEARINGS



Shaft dia. 4 – 10mm

Shaft dia. mm	Identification number									
	Standard	Mass (Ref.) g	Closed end	Mass (Ref.) g	Standard	Mass (Ref.) g	Closed end	Mass (Ref.) g	Grease retained	Mass (Ref.) g
4	—	—	—	—	TLA 48 Z	1.54	TLAM 48	1.67	—	—
	—	—	—	—	—	—	—	—	YTL 48	1.73
5	—	—	—	—	TLA 59 Z	1.9	TLAM 59	2	—	—
	—	—	—	—	—	—	—	—	YTL 59	2.4
6	—	—	—	—	TLA 69 Z	2.2	TLAM 69	2.3	—	—
7	—	—	—	—	TLA 79 Z	2.5	TLAM 79	2.7	—	—
8	—	—	—	—	TLA 810 Z	3.1	TLAM 810	3.3	—	—
	TA 810 Z	6.7	TAM 810	7.1	—	—	—	—	—	—
	TA 815 Z	9.7	TAM 815	10.1	—	—	—	—	—	—
	TA 820 Z	12.9	TAM 820	13.3	—	—	—	—	—	—
	—	—	—	—	—	—	—	—	YT 810	7.7
9	—	—	—	—	TLA 910 Z	3.4	TLAM 910	3.6	—	—
	—	—	—	—	TLA 912 Z	4	TLAM 912	4.3	—	—
	TA 912 Z	8.7	TAM 912	9.2	—	—	—	—	—	—
	TA 916 Z	11.4	TAM 916	11.9	—	—	—	—	—	—
10	—	—	—	—	TLA 1010 Z	3.7	TLAM 1010	4	—	—
	—	—	—	—	TLA 1012 Z	4.4	TLAM 1012	4.8	—	—
	—	—	—	—	TLA 1015 Z	5.5	TLAM 1015	5.9	—	—
	TA 1010 Z	7.9	TAM 1010	8.5	—	—	—	—	—	—
	TA 1012 Z	9.3	TAM 1012	10	—	—	—	—	—	—
	TA 1015 Z	11.5	TAM 1015	12.2	—	—	—	—	—	—
	TA 1020 Z	15.4	TAM 1020	16	—	—	—	—	—	—

Note⁽¹⁾ Allowable rotational speed applies to oil lubrication. For grease lubrication, a maximum of 60% of this value is allowable.
 Remark Shell Type Grease Retained Full Complement Needle Roller Bearings are provided with prepacked grease. Standard type and closed end type bearings are not provided with prepacked grease, so perform proper lubrication when using these types of bearings.



TA...Z TLA...Z

TAM TLAM

YT YTL

Boundary dimensions mm				Standard mounting dimensions mm						Basic dynamic load rating C N	Basic static load rating C ₀ N	Allowable rotational speed ⁽¹⁾ min ⁻¹	Assembled inner ring
F _w	D	C	t ₂ Max.	Shaft dia. h6		Housing bore dia.							
				Max.	Min.	Max. J7	Min.	Max. N7	Min.				
4	8	8	1	4.000	3.992	—	—	7.996	7.981	1 350	1 010	75 000	—
4	8	8	—	—	—	—	—	—	—	3 010	2 900	40 000	—
5	9	9	1	5.000	4.992	—	—	8.996	8.981	1 880	1 600	65 000	—
5	9	9	—	—	—	—	—	—	—	4 320	4 750	30 000	—
6	10	9	1	6.000	5.992	—	—	9.996	9.981	2 100	1 900	55 000	—
7	11	9	1	7.000	6.991	—	—	10.995	10.977	2 490	2 450	50 000	—
8	12	10	1	8.000	7.991	—	—	11.995	11.977	3 320	3 670	45 000	—
8	15	10	1.3	—	—	—	—	—	—	3 470	2 880	45 000	—
8	15	15	1.3	8.000	7.991	15.010	14.992	—	—	5 780	5 570	45 000	—
8	15	20	1.3	—	—	—	—	—	—	8 340	8 920	45 000	—
8	15	10	—	—	—	—	—	—	—	7 530	7 950	19 000	—
9	13	10	1	9.000	8.991	—	—	12.995	12.977	3 500	4 040	45 000	—
9	13	12	1	—	—	—	—	—	—	4 460	5 510	45 000	—
9	16	12	1.3	9.000	8.991	16.010	15.992	—	—	5 140	4 880	45 000	—
9	16	16	1.3	—	—	—	—	—	—	6 960	7 210	45 000	—
9	16	12	—	—	—	—	—	—	—	9 690	11 200	17 000	—
10	14	10	1	10.000	9.991	—	—	13.995	13.977	3 870	4 740	40 000	IRT 710
10	14	12	1	—	—	—	—	—	—	4 920	6 460	40 000	IRT 712
10	14	15	1	—	—	—	—	—	—	6 390	9 040	40 000	IRT 715
10	17	10	1.3	10.000	9.991	17.010	16.992	—	—	4 150	3 780	40 000	IRT 710
10	17	12	1.3	—	—	—	—	—	—	5 590	5 540	40 000	IRT 712
10	17	15	1.3	—	—	—	—	—	—	6 920	7 300	40 000	IRT 715
10	17	20	1.3	—	—	—	—	—	—	9 990	11 700	40 000	—

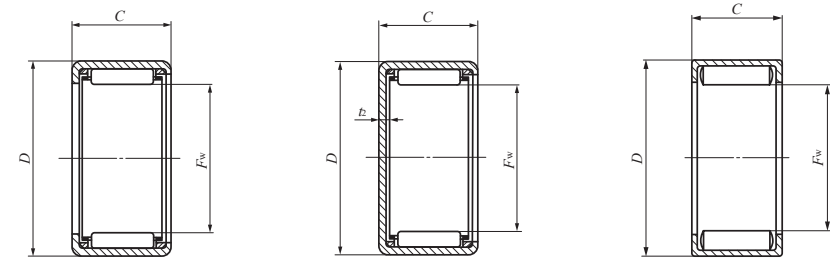
SHELL TYPE NEEDLE ROLLER BEARINGS



Shaft dia. 12 – 15 mm

Shaft dia. mm	Identification number									
	Standard	Mass (Ref.) g	Closed end	Mass (Ref.) g	Standard	Mass (Ref.) g	Closed end	Mass (Ref.) g	Grease retained	Mass (Ref.) g
12	—	—	—	—	TLA 1210 Z	4.3	TLAM 1210	4.7	—	—
	—	—	—	—	—	—	—	—	YTL 1210	5.1
	—	—	—	—	TLA 1212 Z	8.6	TLAM 1212	9.4	—	—
	TA 1212 Z	10.5	TAM 1212	11.5	—	—	—	—	—	—
	TA 1215 Z	13.1	TAM 1215	14	—	—	—	—	—	—
13	TA 1220 Z	17.3	TAM 1220	18.3	—	—	—	—	—	—
	TA 1225 Z	21.5	TAM 1225	22.5	—	—	—	—	—	—
	—	—	—	—	—	—	—	—	YT 1212	12.8
	—	—	—	—	TLA 1312 Z	9.2	TLAM 1312	10.1	—	—
	—	—	—	—	TLA 1412 Z	9.8	TLAM 1412	10.8	—	—
14	—	—	—	—	TLA 1416 Z	13.2	TLAM 1416	14.3	—	—
	TA 1416 Z	18.4	TAM 1416	19.6	—	—	—	—	—	—
	TA 1420 Z	23	TAM 1420	24	—	—	—	—	—	—
15	—	—	—	—	TLA 1512 Z	10.4	TLAM 1512	11.5	—	—
	—	—	—	—	TLA 1516 Z	14	TLAM 1516	15.2	—	—
	—	—	—	—	TLA 1522 Z	19.1	TLAM 1522	20.5	—	—
	TA 1510 Z	10.8	TAM 1510	12.3	—	—	—	—	—	—
	TA 1512 Z	12.9	TAM 1512	14.3	—	—	—	—	—	—
	TA 1515 Z	15.9	TAM 1515	17.3	—	—	—	—	—	—
	TA 1520 Z	21	TAM 1520	22.5	—	—	—	—	—	—
	TA 1525 Z	25	TAM 1525	26.5	—	—	—	—	—	—

Note(1) Allowable rotational speed applies to oil lubrication. For grease lubrication, a maximum of 60% of this value is allowable.
 Remark Shell Type Grease Retained Full Complement Needle Roller Bearings are provided with prepacked grease. Standard type and closed end type bearings are not provided with prepacked grease, so perform proper lubrication when using these types of bearings.



TA...Z TLA...Z

TAM TLAM

YT YTL

Boundary dimensions mm				Standard mounting dimensions mm						Basic dynamic load rating	Basic static load rating	Allowable rotational speed ⁽¹⁾	Assembled inner ring
F _w	D	C	t ₂ Max.	Shaft dia. h6		Housing bore dia.				C N	C ₀ N	min ⁻¹	
				Max.	Min.	J7		N7					
				Max.	Min.	Max.	Min.	Max.	Min.				
12	16	10	1	12.000	11.989	—	—	15.995	15.977	4 350	5 810	35 000	IRT 810
12	16	10	—	—	—	—	—	—	—	7 470	11 800	13 000	IRT 810
12	18	12	1.3	12.000	11.989	—	—	17.995	17.977	6 420	7 490	35 000	IRT 812
12	19	12	1.3	—	—	—	—	—	—	6 000	6 310	35 000	IRT 812
12	19	15	1.3	—	—	—	—	—	—	7 440	8 320	35 000	IRT 815
12	19	20	1.3	12.000	11.989	19.012	18.991	—	—	10 700	13 300	35 000	—
12	19	25	1.3	—	—	—	—	—	—	13 800	18 300	35 000	—
12	19	12	—	—	—	—	—	—	—	11 800	15 200	13 000	IRT 812
13	19	12	1.3	13.000	12.989	—	—	18.993	18.972	6 760	8 170	30 000	IRT 1012
14	20	12	1.3	14.000	13.989	—	—	19.993	19.972	7 080	8 840	30 000	IRT 1012-2
14	20	16	1.3	—	—	—	—	—	—	8 950	12 000	30 000	IRT 1016-2
14	22	16	1.3	14.000	13.989	22.012	21.991	—	—	10 500	12 000	30 000	IRT 1016-2
14	22	20	1.3	—	—	—	—	—	—	13 900	17 200	30 000	IRT 1020-2
15	21	12	1.3	—	—	—	—	—	—	7 380	9 520	25 000	IRT 1212
15	21	16	1.3	15.000	14.989	—	—	20.993	20.972	9 330	12 900	25 000	IRT 1216
15	21	22	1.3	—	—	—	—	—	—	13 600	20 900	25 000	IRT 1222
15	22	10	1.3	—	—	—	—	—	—	5 290	5 680	25 000	IRT 1010-1
15	22	12	1.3	—	—	—	—	—	—	7 120	8 310	25 000	IRT 1012-1
15	22	15	1.3	15.000	14.989	22.012	21.991	—	—	8 830	11 000	25 000	IRT 1015-1
15	22	20	1.3	—	—	—	—	—	—	12 700	17 600	25 000	IRT 1020-1
15	22	25	1.3	—	—	—	—	—	—	16 300	24 200	25 000	IRT 1025-1

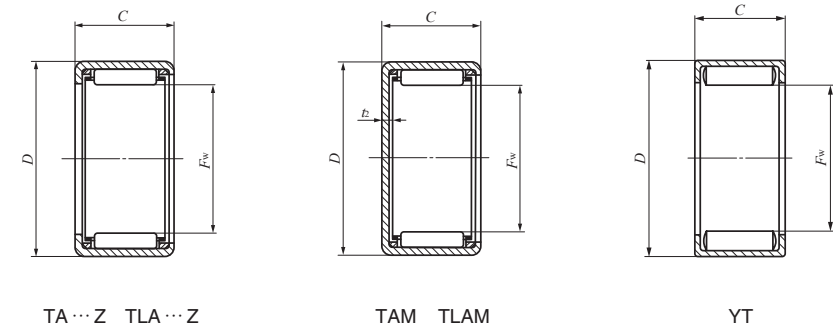
SHELL TYPE NEEDLE ROLLER BEARINGS



Shaft dia. 16 – 19mm

Shaft dia. mm	Identification number									
	Standard	Mass (Ref.) g	Closed end	Mass (Ref.) g	Standard	Mass (Ref.) g	Closed end	Mass (Ref.) g	Grease retained	Mass (Ref.) g
16	—	—	—	—	TLA 1612 Z	10.9	TLAM 1612	12.2	—	—
	—	—	—	—	TLA 1616 Z	14.8	TLAM 1616	16.1	—	—
	—	—	—	—	TLA 1622 Z	20	TLAM 1622	21.5	—	—
16	TA 1616 Z	20	TAM 1616	22	—	—	—	—	—	—
	TA 1620 Z	25	TAM 1620	27	—	—	—	—	—	—
17	—	—	—	—	TLA 1712 Z	11.5	TLAM 1712	13	—	—
	TA 1715 Z	17.6	TAM 1715	19.5	—	—	—	—	—	—
	TA 1720 Z	23.5	TAM 1720	25	—	—	—	—	—	—
	TA 1725 Z	29	TAM 1725	31	—	—	—	—	—	—
	—	—	—	—	—	—	—	—	YT 1715	20.5
	—	—	—	—	—	—	—	—	YT 1725	35.5
18	—	—	—	—	TLA 1812 Z	12	TLAM 1812	13.7	—	—
	—	—	—	—	TLA 1816 Z	16.2	TLAM 1816	17.9	—	—
	TA 1813 Z	16.4	TAM 1813	18.5	—	—	—	—	—	—
	TA 1815 Z	18.5	TAM 1815	20.5	—	—	—	—	—	—
	TA 1817 Z	21	TAM 1817	23	—	—	—	—	—	—
	TA 1819 Z	23.5	TAM 1819	25.5	—	—	—	—	—	—
	TA 1820 Z	24.5	TAM 1820	26.5	—	—	—	—	—	—
	TA 1825 Z	30.5	TAM 1825	32.5	—	—	—	—	—	—
19	TA 1916 Z	23	TAM 1916	25.5	—	—	—	—	—	—
	TA 1920 Z	29	TAM 1920	31	—	—	—	—	—	—

Note(1) Allowable rotational speed applies to oil lubrication. For grease lubrication, a maximum of 60% of this value is allowable.
 Remark Shell Type Grease Retained Full Complement Needle Roller Bearings are provided with prepacked grease. Standard type and closed end type bearings are not provided with prepacked grease, so perform proper lubrication when using these types of bearings.



Boundary dimensions mm				Standard mounting dimensions mm						Basic dynamic load rating	Basic static load rating	Allowable rotational speed ⁽¹⁾	Assembled inner ring
F _w	D	C	t ₂ Max.	Shaft dia. h6		Housing bore dia.				C N	C ₀ N	min ⁻¹	
				Max.	Min.	J7		N7					
16	22	12	1.3	—	—	—	—	—	—	7 670	10 200	25 000	IRT 1212-1
16	22	16	1.3	16.000	15.989	—	—	21.993	21.972	9 700	13 800	25 000	IRT 1216-1
16	22	22	1.3	—	—	—	—	—	—	14 200	22 400	25 000	IRT 1222-1
16	24	16	1.3	—	—	—	—	—	—	11 100	13 300	25 000	IRT 1216-1
16	24	20	1.3	16.000	15.989	24.012	23.991	—	—	14 700	19 100	25 000	IRT 1220-1
17	23	12	1.3	17.000	16.989	—	—	22.993	22.972	7 960	10 900	25 000	—
17	24	15	1.3	—	—	—	—	—	—	9 660	12 700	25 000	IRT 1215-2
17	24	20	1.3	—	—	—	—	—	—	13 900	20 400	25 000	IRT 1220-2
17	24	25	1.3	17.000	16.989	24.012	23.991	—	—	17 900	28 100	25 000	IRT 1225-2
17	24	15	—	—	—	—	—	—	—	16 600	26 000	9 000	IRT 1215-2
17	24	25	—	—	—	—	—	—	—	27 200	49 000	9 000	IRT 1225-2
18	24	12	1.3	—	—	—	—	—	—	8 230	11 500	20 000	IRT 1512
18	24	16	1.3	18.000	17.989	—	—	23.993	23.972	10 400	15 600	20 000	IRT 1516
18	25	13	1.3	—	—	—	—	—	—	9 100	12 000	20 000	IRT 1513
18	25	15	1.3	—	—	—	—	—	—	10 100	13 600	20 000	IRT 1515
18	25	17	1.3	—	—	—	—	—	—	11 900	16 900	20 000	IRT 1517
18	25	19	1.3	18.000	17.989	25.012	24.991	—	—	13 700	20 200	20 000	IRT 1519
18	25	20	1.3	—	—	—	—	—	—	14 500	21 800	20 000	IRT 1520
18	25	25	1.3	—	—	—	—	—	—	18 600	30 000	20 000	IRT 1525
19	27	16	1.3	—	—	—	—	—	—	12 200	15 700	20 000	IRT 1516-1
19	27	20	1.3	19.000	18.987	27.012	26.991	—	—	16 100	22 600	20 000	IRT 1520-1

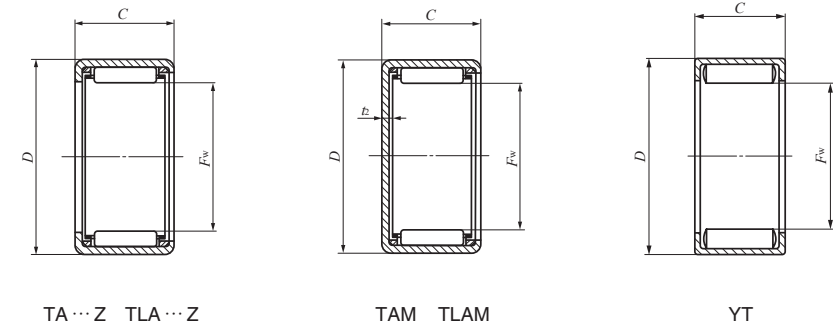
SHELL TYPE NEEDLE ROLLER BEARINGS



Shaft dia. 20 – 21mm

Shaft dia. mm	Identification number									
	Standard	Mass (Ref.) g	Closed end	Mass (Ref.) g	Standard	Mass (Ref.) g	Closed end	Mass (Ref.) g	Grease retained	Mass (Ref.) g
20	—	—	—	—	TLA 2012 Z	13.2	TLAM 2012	15.2	—	—
	—	—	—	—	TLA 2016 Z	17.8	TLAM 2016	19.9	—	—
	—	—	—	—	TLA 2020 Z	22	TLAM 2020	24	—	—
	—	—	—	—	TLA 2030 Z	33	TLAM 2030	35	—	—
	TA 2015 Z	20	TAM 2015	22.5	—	—	—	—	—	—
	TA 2020 Z	26.5	TAM 2020	29	—	—	—	—	—	—
	TA 2025 Z	33	TAM 2025	35.5	—	—	—	—	—	—
	TA 2030 Z	39.5	TAM 2030	42	—	—	—	—	—	—
	—	—	—	—	—	—	—	—	YT 2015	23.5
	—	—	—	—	—	—	—	—	YT 2025	41
20	TA 202820 Z	30	TAM 202820	32.5	—	—	—	—	—	—
	—	—	—	—	—	—	—	—	YT 202820	37.5
21	TA 2116 Z	25	TAM 2116	28	—	—	—	—	—	—
	TA 2120 Z	31.5	TAM 2120	34.5	—	—	—	—	—	—
	—	—	—	—	—	—	—	—	YT 2116	31
	—	—	—	—	—	—	—	—	YT 2120	39

Note(1) Allowable rotational speed applies to oil lubrication. For grease lubrication, a maximum of 60% of this value is allowable.
 Remark Shell Type Grease Retained Full Complement Needle Roller Bearings are provided with prepacked grease. Standard type and closed end type bearings are not provided with prepacked grease, so perform proper lubrication when using these types of bearings.



Boundary dimensions mm				Standard mounting dimensions mm						Basic dynamic load rating	Basic static load rating	Allowable rotational speed ⁽¹⁾	Assembled inner ring
F_w	D	C	t_2 Max.	Shaft dia. h6		Housing bore dia.				C N	C_0 N	min ⁻¹	
				Max.	Min.	J7		N7					
20	26	12	1.3							8 740	12 900	20 000	—
20	26	16	1.3	20.000	19.987	—	—	25.993	25.972	11 100	17 500	20 000	IRT 1716
20	26	20	1.3							14 500	24 700	20 000	IRT 1720
20	26	30	1.3							22 300	42 900	20 000	IRT 1730
20	27	15	1.3							10 400	14 600	20 000	IRT 1515-2
20	27	20	1.3							15 000	23 400	20 000	IRT 1520-2
20	27	25	1.3	20.000	19.987	27.012	26.991	—	—	19 200	32 200	20 000	IRT 1525-2
20	27	30	1.3							23 100	41 000	20 000	IRT 1530-2
20	27	15	—							18 400	30 900	7 500	IRT 1515-2
20	27	25	—							30 000	58 300	7 500	IRT 1525-2
20	28	20	1.3	20.000	19.987	28.012	27.991	—	—	16 900	24 300	20 000	IRT 1520-2
20	28	20	—							26 800	44 600	7 500	IRT 1520-2
21	29	16	1.3							13 300	18 100	19 000	IRT 1716-1
21	29	20	1.3	21.000	20.987	29.012	28.991	—	—	17 600	25 900	19 000	IRT 1720-1
21	29	16	—							22 100	35 200	7 000	IRT 1716-1
21	29	20	—							27 500	46 800	7 000	IRT 1720-1

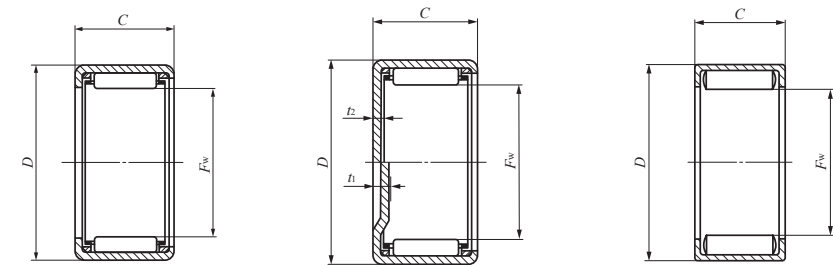
SHELL TYPE NEEDLE ROLLER BEARINGS



Shaft dia. 22 – 24mm

Shaft dia. mm	Identification number									
	Standard	Mass (Ref.) g	Closed end	Mass (Ref.) g	Standard	Mass (Ref.) g	Closed end	Mass (Ref.) g	Grease retained	Mass (Ref.) g
22	—	—	—	—	TLA 2212 Z	15.6	TLAM 2212	18.1	—	—
	—	—	—	—	TLA 2216 Z	21.5	TLAM 2216	24	—	—
	—	—	—	—	TLA 2220 Z	26.5	TLAM 2220	29	—	—
	TA 2210 Z	15	TAM 2210	18.1	—	—	—	—	—	—
	TA 2215 Z	21.5	TAM 2215	24.5	—	—	—	—	—	—
	TA 2220 Z	29	TAM 2220	32	—	—	—	—	—	—
	TA 2225 Z	35.5	TAM 2225	38.5	—	—	—	—	—	—
	TA 2230 Z	42.5	TAM 2230	45.5	—	—	—	—	—	—
	TA 223016 Z	26	TAM 223016	29	—	—	—	—	—	—
	TA 223020 Z	32.5	TAM 223020	35.5	—	—	—	—	—	—
—	—	—	—	—	—	—	—	YT 223016	32	
—	—	—	—	—	—	—	—	YT 223020	40.5	
24	TA 2420 Z	31	TAM 2420	35	—	—	—	—	—	—
	TA 2428 Z	43.5	TAM 2428	47	—	—	—	—	—	—
	—	—	—	—	—	—	—	—	YT 2428	54
	TA 243216 Z	28	TAM 243216	32	—	—	—	—	—	—
	TA 243220 Z	35.5	TAM 243220	39	—	—	—	—	—	—
	—	—	—	—	—	—	—	—	YT 243216	34.5
	—	—	—	—	—	—	—	—	YT 243220	43.5
	—	—	—	—	—	—	—	—	—	—

Note(1) Allowable rotational speed applies to oil lubrication. For grease lubrication, a maximum of 60% of this value is allowable.
 Remark Shell Type Grease Retained Full Complement Needle Roller Bearings are provided with prepacked grease. Standard type and closed end type bearings are not provided with prepacked grease, so perform proper lubrication when using these types of bearings.



TA...Z TLA...Z

TAM TLAM
 $t_1 (F_w \geq 24)$
 $t_2 (F_w \leq 22)$

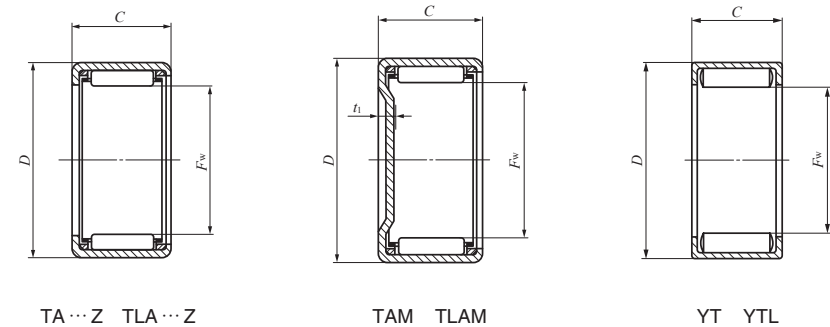
YT

Boundary dimensions mm				Standard mounting dimensions mm						Basic dynamic load rating	Basic static load rating	Allowable rotational speed ⁽¹⁾	Assembled inner ring
F_w	D	C	t_1, t_2 Max.	Shaft dia. h6		Housing bore dia.				C N	C_0 N	min ⁻¹	
				Max.	Min.	J7		N7					
22	28	12	1.3							9 230	14 300	18 000	—
22	28	16	1.3	22.000	21.987	—	—	27.993	27.972	11 700	19 300	18 000	IRT 1716-2
22	28	20	1.3							15 300	27 300	18 000	IRT 1720-2
22	29	10	1.3							6 650	8 500	18 000	IRT 1710-2
22	29	15	1.3							11 100	16 400	18 000	IRT 1715-2
22	29	20	1.3	22.000	21.987	29.012	28.991	—	—	16 000	26 300	18 000	IRT 1720-2
22	29	25	1.3							19 700	34 300	18 000	IRT 1725-2
22	29	30	1.3							23 800	43 700	18 000	IRT 1730-2
22	30	16	1.3							13 200	18 200	18 000	IRT 1716-2
22	30	20	1.3	22.000	21.987	30.012	29.991	—	—	17 500	26 100	18 000	IRT 1720-2
22	30	16	—							22 600	36 800	7 000	IRT 1716-2
22	30	20	—							28 200	48 900	7 000	IRT 1720-2
24	31	20	3.4							17 000	29 200	16 000	IRT 2020
24	31	28	3.4	24.000	23.987	31.014	30.989	—	—	24 500	46 700	16 000	IRT 2028
24	31	28	—							36 800	79 900	6 500	IRT 2028
24	32	16	3.4							14 200	20 500	16 000	IRT 2016
24	32	20	3.4	24.000	23.987	32.014	31.989	—	—	18 800	29 400	16 000	IRT 2020
24	32	16	—							23 700	40 100	6 500	IRT 2016
24	32	20	—							29 500	53 200	6 500	IRT 2020

SHELL TYPE NEEDLE ROLLER BEARINGS

B

TA
TLA
BA
BHA



Shaft dia. 25 – 28 mm

Shaft dia. mm	Identification number									
	Standard	Mass (Ref.) g	Closed end	Mass (Ref.) g	Standard	Mass (Ref.) g	Closed end	Mass (Ref.) g	Grease retained	Mass (Ref.) g
25	—	—	—	—	TLA 2512 Z	19.7	TLAM 2512	23.5	—	—
	—	—	—	—	TLA 2516 Z	26	TLAM 2516	29.5	—	—
	—	—	—	—	TLA 2520 Z	32	TLAM 2520	36	—	—
	—	—	—	—	TLA 2526 Z	41.5	TLAM 2526	45.5	—	—
	—	—	—	—	TLAW2538Z	58.5	TLAMW2538	62	—	—
	—	—	—	—	—	—	—	—	YTL 2526	51.5
	TA 2510 Z	19.1	TAM 2510	23	—	—	—	—	—	—
	TA 2515 Z	28.5	TAM 2515	32.5	—	—	—	—	—	—
	TA 2520 Z	36.5	TAM 2520	40.5	—	—	—	—	—	—
	TA 2525 Z	45.5	TAM 2525	49	—	—	—	—	—	—
	TA 2530 Z	54.5	TAM 2530	58.5	—	—	—	—	—	—
	—	—	—	—	—	—	—	—	YT 2510	22.5
	—	—	—	—	—	—	—	—	YT 2515	33
	—	—	—	—	—	—	—	—	YT 2520	45
	—	—	—	—	—	—	—	—	YT 2525	57
26	TA 2616 Z	30.5	TAM 2616	34.5	—	—	—	—	—	—
	TA 2620 Z	38	TAM 2620	42.5	—	—	—	—	—	—
	—	—	—	—	—	—	—	—	YT 2616	37
	—	—	—	—	—	—	—	—	YT 2620	46.5
	—	—	—	—	—	—	—	—	—	—
28	—	—	—	—	TLA 2816 Z	28.5	TLAM 2816	33.5	—	—
	—	—	—	—	TLA 2820 Z	35.5	TLAM 2820	40.5	—	—
	TA 2820 Z	45	TAM 2820	50	—	—	—	—	—	—
	TA 2830 Z	67.5	TAM 2830	72.5	—	—	—	—	—	—
	—	—	—	—	—	—	—	—	YT 2820	56.5
	—	—	—	—	—	—	—	—	—	—
	—	—	—	—	—	—	—	—	—	—

Note(1) Allowable rotational speed applies to oil lubrication. For grease lubrication, a maximum of 60% of this value is allowable.
 Remarks1. "W" in the identification number indicates that rolling elements are arranged in double rows.
 2. Shell Type Grease Retained Full Complement Needle Roller Bearings are provided with prepacked grease. Standard type and closed end type bearings are not provided with prepacked grease, so perform proper lubrication when using these types of bearings.

Boundary dimensions mm				Standard mounting dimensions mm						Basic dynamic load rating	Basic static load rating	Allowable rotational speed ⁽¹⁾	Assembled inner ring
F _w	D	C	t ₁ Max.	Shaft dia. h6		Housing bore dia.				C N	C ₀ N	min ⁻¹	
				Max.	Min.	J7		N7					
25	32	12	2.8							9 440	13 900	15 000	—
25	32	16	2.8							12 800	20 500	15 000	—
25	32	20	2.8	25.000	24.987	—	—	31.992	31.967	16 900	29 300	15 000	IRT 2020-1
25	32	26	2.8							22 600	42 500	15 000	IRT 2026-1
25	32	38	2.8							28 900	58 500	15 000	IRT 2038-1
25	32	26	—							35 000	75 800	6 000	IRT 2026-1
25	33	10	3.4							7 990	9 900	15 000	IRT 2010-1
25	33	15	3.4							13 400	19 300	15 000	IRT 2015-1
25	33	20	3.4	25.000	24.987	33.014	32.989	—	—	19 500	31 100	15 000	IRT 2020-1
25	33	25	3.4							24 100	40 800	15 000	IRT 2025-1
25	33	30	3.4							29 100	52 000	15 000	IRT 2030-1
25	33	10	—							15 500	23 600	6 000	IRT 2010-1
25	33	15	—	25.000	24.987	33.014	32.989	—	—	22 700	38 300	6 000	IRT 2015-1
25	33	20	—							30 200	55 400	6 000	IRT 2020-1
25	33	25	—							37 200	72 500	6 000	IRT 2025-1
26	34	16	3.4							15 200	22 900	15 000	IRT 2216
26	34	20	3.4	26.000	25.987	34.014	33.989	—	—	20 100	32 800	15 000	IRT 2220
26	34	16	—							24 700	43 300	6 000	IRT 2216
26	34	20	—							30 800	57 500	6 000	IRT 2220
28	35	16	2.8							13 800	23 500	13 000	—
28	35	20	2.8	28.000	27.987	—	—	34.992	34.967	18 300	33 600	13 000	IRT 2220-1
28	37	20	3.4							21 200	32 300	13 000	IRT 2220-1
28	37	30	3.4	28.000	27.987	37.014	36.989	—	—	33 000	56 900	13 000	IRT 2230-1
28	37	20	—							34 700	61 700	5 500	IRT 2220-1

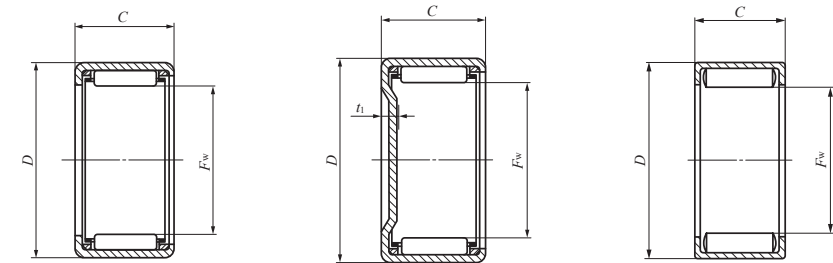
SHELL TYPE NEEDLE ROLLER BEARINGS



Shaft dia. 29 – 35mm

Shaft dia. mm	Identification number									
	Standard	Mass (Ref.) g	Closed end	Mass (Ref.) g	Standard	Mass (Ref.) g	Closed end	Mass (Ref.) g	Grease retained	Mass (Ref.) g
29	TA 2920 Z	47	TAM 2920	52	—	—	—	—	—	—
	TA 2930 Z	70	TAM 2930	75.5	—	—	—	—	—	—
	—	—	—	—	—	—	—	—	YT 2920	58.5
30	—	—	—	—	TLA 3012 Z	23.5	TLAM 3012	29	—	—
	—	—	—	—	TLA 3016 Z	30.5	TLAM 3016	36	—	—
	—	—	—	—	TLA 3018 Z	34.5	TLAM 3018	40	—	—
	—	—	—	—	TLA 3020 Z	38	TLAM 3020	43.5	—	—
	—	—	—	—	TLA 3026 Z	49	TLAM 3026	54.5	—	—
	—	—	—	—	TLAW3038 Z	69	TLAMW3038	74.5	—	—
	TA 3013 Z	36.5	TAM 3013	42.5	—	—	—	—	—	—
	TA 3015 Z	42	TAM 3015	47.5	—	—	—	—	—	—
	TA 3020 Z	54.5	TAM 3020	60	—	—	—	—	—	—
	TA 3025 Z	68	TAM 3025	73.5	—	—	—	—	—	—
TA 3030 Z	80	TAM 3030	85.5	—	—	—	—	—	—	
32	TA 3220 Z	57.5	TAM 3220	63.5	—	—	—	—	—	—
	TA 3230 Z	86	TAM 3230	97.5	—	—	—	—	—	—
	—	—	—	—	—	—	—	—	YT 3220	71.5
35	—	—	—	—	TLA 3512 Z	27	TLAM 3512	34.5	—	—
	—	—	—	—	TLA 3516 Z	35	TLAM 3516	42.5	—	—
	—	—	—	—	TLA 3520 Z	43.5	TLAM 3520	51	—	—
	TA 3512 Z	38.5	TAM 3512	46	—	—	—	—	—	—
	TA 3515 Z	48	TAM 3515	56	—	—	—	—	—	—
	TA 3520 Z	62.5	TAM 3520	70	—	—	—	—	—	—
	TA 3525 Z	78	TAM 3525	85.5	—	—	—	—	—	—
	TA 3530 Z	97	TAM 3530	105	—	—	—	—	—	—

Note(1) Allowable rotational speed applies to oil lubrication. For grease lubrication, a maximum of 60% of this value is allowable.
 Remarks1. "W" in the identification number indicates that rolling elements are arranged in double rows.
 2. Shell Type Grease Retained Full Complement Needle Roller Bearings are provided with prepacked grease. Standard type and closed end type bearings are not provided with prepacked grease, so perform proper lubrication when using these types of bearings.



TA...Z TLA...Z

TAM TLAM

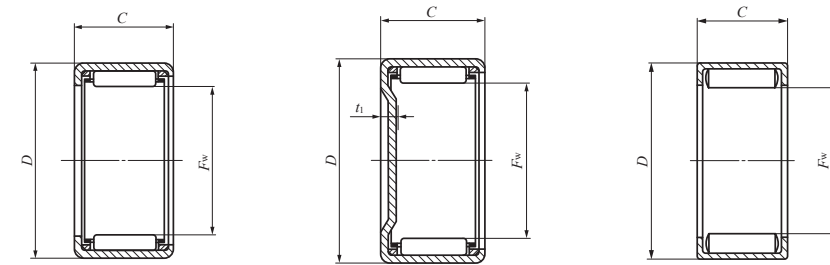
YT

Boundary dimensions mm				Standard mounting dimensions mm						Basic dynamic load rating	Basic static load rating	Allowable rotational speed ⁽¹⁾	Assembled inner ring
F _w	D	C	t ₁ Max.	Shaft dia. h6		Housing bore dia. J7				C N	C ₀ N	min ⁻¹	
				Max.	Min.	Max.	Min.	Max.	Min.				
29	38	20	3.4							22 000	34 200	13 000	IRT 2520
29	38	30	3.4	29.000	28.987	38.014	37.989	—	—	34 200	60 300	13 000	IRT 2530
29	38	20	—							35 500	64 100	5 000	IRT 2520
30	37	12	2.8							10 400	16 600	12 000	—
30	37	16	2.8							14 100	24 500	12 000	—
30	37	18	2.8	30.000	29.987	—	—	36.992	36.967	16 400	29 800	12 000	—
30	37	20	2.8							18 600	35 100	12 000	IRT 2520-1
30	37	26	2.8							24 800	50 900	12 000	IRT 2526-1
30	37	38	2.8							31 900	70 200	12 000	IRT 2538-1
30	40	13	3.4							13 500	16 800	12 000	—
30	40	15	3.4							16 800	22 400	12 000	IRT 2515-1
30	40	20	3.4	30.000	29.987	40.014	39.989	—	—	24 500	36 300	12 000	IRT 2520-1
30	40	25	3.4							31 600	50 300	12 000	IRT 2525-1
30	40	30	3.4							36 700	60 700	12 000	IRT 2530-1
32	42	20	3.4							25 400	38 600	11 000	IRT 2820
32	42	30	3.4	32.000	31.984	42.014	41.989	—	—	39 500	68 400	11 000	IRT 2830
32	42	20	—							39 900	70 100	4 500	IRT 2820
35	42	12	2.8							11 600	20 000	10 000	IRT 3012
35	42	16	2.8	35.000	34.984	—	—	41.992	41.967	15 700	29 600	10 000	—
35	42	20	2.8							20 700	42 300	10 000	IRT 3020
35	45	12	3.4							14 800	19 900	10 000	IRT 3012
35	45	15	3.4							18 500	26 500	10 000	IRT 3015
35	45	20	3.4	35.000	34.984	45.014	44.989	—	—	27 000	43 100	10 000	IRT 3020
35	45	25	3.4							34 800	59 700	10 000	IRT 3025
35	45	30	3.4							40 600	72 600	10 000	IRT 3030

SHELL TYPE NEEDLE ROLLER BEARINGS

B

TA
TLA
BA
BHA



TA...Z TLA...Z

TAM TLAM

YT

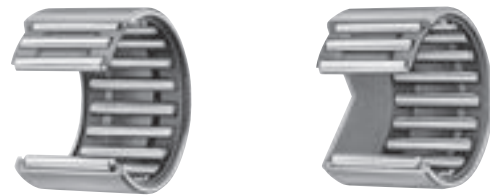
Shaft dia. 37 – 45mm

Shaft dia. mm	Identification number									
	Standard	Mass (Ref.) g	Closed end	Mass (Ref.) g	Standard	Mass (Ref.) g	Closed end	Mass (Ref.) g	Grease retained	Mass (Ref.) g
37	TA 3720 Z	64.5	TAM 3720	73	—	—	—	—	—	—
	TA 3730 Z	101	TAM 3730	110	—	—	—	—	—	—
	—	—	—	—	—	—	—	—	YT 3720	81
38	TA 3815 Z	51	TAM 3815	60	—	—	—	—	—	—
	TA 3820 Z	65.5	TAM 3820	74.5	—	—	—	—	—	—
	TA 3825 Z	82.5	TAM 3825	96	—	—	—	—	—	—
	TA 3830 Z	104	TAM 3830	114	—	—	—	—	—	—
	TAW 3845 Z	149	TAMW 3845	159	—	—	—	—	—	—
40	—	—	—	—	TLA 4012 Z	30	TLAM 4012	40	—	—
	—	—	—	—	TLA 4016 Z	39	TLAM 4016	49	—	—
	—	—	—	—	TLA 4020 Z	49	TLAM 4020	58.5	—	—
	TA 4015 Z	54	TAM 4015	63.5	—	—	—	—	—	—
	TA 4020 Z	69.5	TAM 4020	79	—	—	—	—	—	—
	TA 4025 Z	86.5	TAM 4025	102	—	—	—	—	—	—
	TA 4030 Z	110	TAM 4030	120	—	—	—	—	—	—
	TA 4040 Z	144	TAM 4040	154	—	—	—	—	—	—
	—	—	—	—	—	—	—	—	YT 4015	63.5
	—	—	—	—	—	—	—	—	YT 4025	109
	45	—	—	—	—	TLA 4516 Z	43.5	TLAM 4516	56	—
—		—	—	—	TLA 4520 Z	54.5	TLAM 4520	67	—	—
TA 4520 Z		77	TAM 4520	90	—	—	—	—	—	—
TA 4525 Z		102	TAM 4525	115	—	—	—	—	—	—
TA 4530 Z		122	TAM 4530	135	—	—	—	—	—	—
TA 4540 Z		161	TAM 4540	174	—	—	—	—	—	—
—		—	—	—	—	—	—	—	—	—
—		—	—	—	—	—	—	—	—	—
—		—	—	—	—	—	—	—	YT 4520	96
—		—	—	—	—	—	—	—	YT 4525	122

Boundary dimensions mm				Standard mounting dimensions mm						Basic dynamic load rating	Basic static load rating	Allowable rotational speed ⁽¹⁾	Assembled inner ring
F _w	D	C	t ₁ Max.	Shaft dia. h6		Housing bore dia.				C N	C ₀ N	min ⁻¹	
				Max.	Min.	J7		N7					
				Max.	Min.	Max.	Min.	Max.	Min.				
37	47	20	3.4							27 800	45 400	9 500	IRT 3220
37	47	30	3.4	37.000	36.984	47.014	46.989	—	—	41 800	76 700	9 500	IRT 3230
37	47	20	—							43 300	81 300	4 000	IRT 3220
38	48	15	3.4							19 000	28 000	9 000	IRT 3215-1
38	48	20	3.4							27 700	45 600	9 000	IRT 3220-1
38	48	25	3.4	38.000	37.984	48.014	47.989	—	—	35 600	63 100	9 000	IRT 3225-1
38	48	30	3.4							43 100	80 600	9 000	IRT 3230-1
38	48	45	3.4							55 700	112 000	9 000	IRT 3245-1
40	47	12	2.8							12 400	22 800	8 500	—
40	47	16	2.8	40.000	39.984	—	—	46.992	46.967	16 700	33 700	8 500	—
40	47	20	2.8							22 100	48 200	8 500	IRT 3520
40	50	15	3.4							19 500	29 400	8 500	IRT 3515
40	50	20	3.4							28 400	47 800	8 500	IRT 3520
40	50	25	3.4							36 600	66 200	8 500	IRT 3525
40	50	30	3.4	40.000	39.984	50.014	49.989	—	—	44 300	84 600	8 500	IRT 3530
40	50	40	3.4							56 700	116 000	8 500	IRT 3540
40	50	15	—							33 400	59 800	4 000	IRT 3515
40	50	25	—							55 300	114 000	4 000	IRT 3525
45	52	16	2.8							17 800	37 800	7 500	—
45	52	20	2.8	45.000	44.984	—	—	51.991	51.961	23 400	54 000	7 500	IRT 4020
45	55	20	3.4							30 600	54 600	7 500	IRT 4020
45	55	25	3.4							39 400	75 600	7 500	IRT 4025
45	55	30	3.4							47 700	96 600	7 500	IRT 4030
45	55	40	3.4	45.000	44.984	55.018	54.988	—	—	61 300	133 000	7 500	IRT 4040
45	55	20	—							47 800	98 200	3 500	IRT 4020
45	55	25	—							59 100	129 000	3 500	IRT 4025

Note⁽¹⁾ Allowable rotational speed applies to oil lubrication. For grease lubrication, a maximum of 60% of this value is allowable.
 Remarks1. "W" in the identification number indicates that rolling elements are arranged in double rows.
 2. Shell Type Grease Retained Full Complement Needle Roller Bearings are provided with prepacked grease. Standard type and closed end type bearings are not provided with prepacked grease, so perform proper lubrication when using these types of bearings.

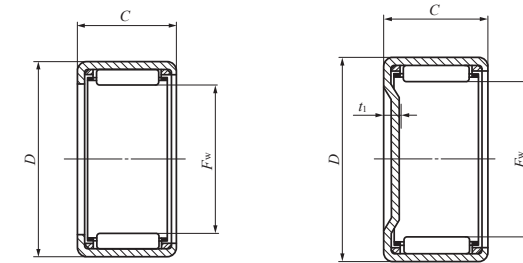
SHELL TYPE NEEDLE ROLLER BEARINGS



Shaft dia. 50 – 62mm

Shaft dia. mm	Identification number									
	Standard	Mass (Ref.) g	Closed end	Mass (Ref.) g	Standard	Mass (Ref.) g	Closed end	Mass (Ref.) g	Grease retained	Mass (Ref.) g
50	—	—	—	—	TLA 5020 Z	69	TLAM 5020	84.5	—	—
	—	—	—	—	TLA 5025 Z	86	TLAM 5025	107	—	—
	TA 5012 Z	62.5	TAM 5012	78	—	—	—	—	—	—
	TA 5015 Z	78	TAM 5015	98.5	—	—	—	—	—	—
	TA 5020 Z	107	TAM 5020	123	—	—	—	—	—	—
	TA 5025 Z	134	TAM 5025	150	—	—	—	—	—	—
	TA 5030 Z	161	TAM 5030	178	—	—	—	—	—	—
	TA 5040 Z	210	TAM 5040	230	—	—	—	—	—	—
TAW 5045 Z	230	TAMW 5045	245	—	—	—	—	—	—	
55	—	—	—	—	TLA 5520 Z	75	TLAM 5520	98.5	—	—
	—	—	—	—	TLA 5525 Z	98.5	TLAM 5525	118	—	—
	TA 5520 Z	116	TAM 5520	136	—	—	—	—	—	—
	TA 5525 Z	145	TAM 5525	165	—	—	—	—	—	—
	TA 5530 Z	175	TAM 5530	195	—	—	—	—	—	—
	TA 5540 Z	230	TAM 5540	250	—	—	—	—	—	—
	TAW 5545 Z	250	TAMW 5545	270	—	—	—	—	—	—
	TAW 5550 Z	280	TAMW 5550	300	—	—	—	—	—	—
60	TA 6025 Z	158	TAM 6025	182	—	—	—	—	—	—
	TA 6030 Z	191	TAM 6030	215	—	—	—	—	—	—
	TA 6040 Z	250	TAM 6040	275	—	—	—	—	—	—
	TAW 6045 Z	270	TAMW 6045	295	—	—	—	—	—	—
	TAW 6050 Z	305	TAMW 6050	330	—	—	—	—	—	—
62	TA 6212 Z	78	TAM 6212	107	—	—	—	—	—	—

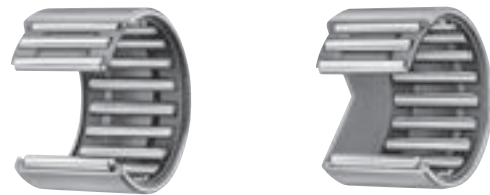
Note(1) Allowable rotational speed applies to oil lubrication. For grease lubrication, a maximum of 60% of this value is allowable.
 Remarks1. "W" in the identification number indicates that rolling elements are arranged in double rows.
 2. Shell Type Grease Retained Full Complement Needle Roller Bearings are provided with prepacked grease. Standard type and closed end type bearings are not provided with prepacked grease, so perform proper lubrication when using these types of bearings.



TA...Z TLA...Z

TAM TLAM

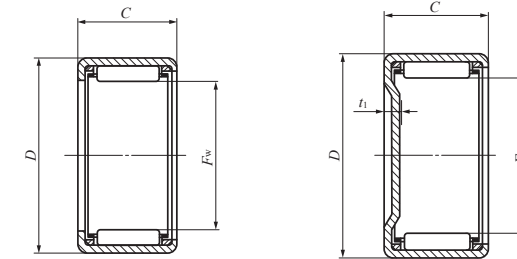
Boundary dimensions mm				Standard mounting dimensions mm						Basic dynamic load rating	Basic static load rating	Allowable rotational speed ⁽¹⁾	Assembled inner ring
F _w	D	C	t ₁ Max.	Shaft dia. h6		Housing bore dia.				C N	C ₀ N	min ⁻¹	
				Max.	Min.	J7		N7					
50	58	20	2.8	50.000	49.984	—	—	57.991	57.961	28 800	64 100	6 500	IRT 4520
50	58	25	2.8	—	—	—	—	—	—	36 900	88 400	6 500	IRT 4525
50	62	12	3.4	—	—	—	—	—	—	17 700	24 000	6 500	IRT 4512
50	62	15	3.4	—	—	—	—	—	—	25 800	39 000	6 500	IRT 4515
50	62	20	3.4	—	—	—	—	—	—	38 000	64 000	6 500	IRT 4520
50	62	25	3.4	50.000	49.984	62.018	61.988	—	—	49 100	89 000	6 500	IRT 4525
50	62	30	3.4	—	—	—	—	—	—	59 500	114 000	6 500	IRT 4530
50	62	40	3.4	—	—	—	—	—	—	76 500	157 000	6 500	IRT 4540
50	62	45	3.4	—	—	—	—	—	—	76 700	158 000	6 500	IRT 4545
55	63	20	2.8	55.000	54.981	—	—	62.991	62.961	29 800	69 400	5 500	IRT 5020-1
55	63	25	2.8	—	—	—	—	—	—	38 300	95 700	5 500	IRT 5025-1
55	67	20	3.4	—	—	—	—	—	—	39 600	69 700	5 500	IRT 5020-1
55	67	25	3.4	—	—	—	—	—	—	51 200	97 000	5 500	IRT 5025-1
55	67	30	3.4	55.000	54.981	67.018	66.988	—	—	62 000	124 000	5 500	IRT 5030-1
55	67	40	3.4	—	—	—	—	—	—	80 000	172 000	5 500	IRT 5040-1
55	67	45	3.4	—	—	—	—	—	—	79 900	172 000	5 500	IRT 5045-1
55	67	50	3.4	—	—	—	—	—	—	91 500	205 000	5 500	IRT 5050-1
60	72	25	3.4	—	—	—	—	—	—	54 700	108 000	5 000	IRT 5025
60	72	30	3.4	—	—	—	—	—	—	66 300	139 000	5 000	IRT 5030
60	72	40	3.4	60.000	59.981	72.018	71.988	—	—	85 700	193 000	5 000	IRT 5040
60	72	45	3.4	—	—	—	—	—	—	85 400	193 000	5 000	IRT 5045
60	72	50	3.4	—	—	—	—	—	—	97 800	229 000	5 000	IRT 5050
62	74	12	3.4	62.000	61.981	74.018	73.988	—	—	20 100	30 300	4 500	IRT 5212



Shaft dia. 65 – 70mm

Shaft dia. mm	Identification number									
	Standard	Mass (Ref.) g	Closed end	Mass (Ref.) g	Standard	Mass (Ref.) g	Closed end	Mass (Ref.) g	Grease retained	Mass (Ref.) g
65	TA 6525 Z	169	TAM 6525	197	—	—	—	—	—	—
	TA 6530 Z	205	TAM 6530	230	—	—	—	—	—	—
	TAW 6545 Z	290	TAMW 6545	315	—	—	—	—	—	—
	TAW 6550 Z	330	TAMW 6550	355	—	—	—	—	—	—
70	TA 7025 Z	181	TAM 7025	215	—	—	—	—	—	—
	TA 7030 Z	220	TAM 7030	250	—	—	—	—	—	—
	TA 7040 Z	290	TAM 7040	320	—	—	—	—	—	—
	TAW 7050 Z	350	TAMW 7050	380	—	—	—	—	—	—

Note(1) Allowable rotational speed applies to oil lubrication. For grease lubrication, a maximum of 60% of this value is allowable.
 Remarks1. "W" in the identification number indicates that rolling elements are arranged in double rows.
 2. Shell Type Grease Retained Full Complement Needle Roller Bearings are provided with prepacked grease. Standard type and closed end type bearings are not provided with prepacked grease, so perform proper lubrication when using these types of bearings.



TA...Z

TAM

Boundary dimensions mm				Standard mounting dimensions mm						Basic dynamic load rating	Basic static load rating	Allowable rotational speed ⁽¹⁾	Assembled inner ring
F _w	D	C	t ₁ Max.	Shaft dia. h6		Housing bore dia.				C N	C ₀ N	min ⁻¹	
				Max.	Min.	Max.	Min.	Max.	Min.				
65	77	25	3.4							56 500	116 000	4 000	IRT 5525
65	77	30	3.4	65.000	64.981	77.018	76.988	—	—	68 500	149 000	4 000	IRT 5530
65	77	45	3.4							88 300	207 000	4 000	IRT 5545
65	77	50	3.4							101 000	246 000	4 000	IRT 5550
70	82	25	3.4							58 500	124 000	3 500	IRT 6025
70	82	30	3.4	70.000	69.981	82.022	81.987	—	—	70 900	159 000	3 500	IRT 6030
70	82	40	3.4							92 000	222 000	3 500	IRT 6040
70	82	50	3.4							105 000	262 000	3 500	IRT 6050

SHELL TYPE NEEDLE ROLLER BEARINGS

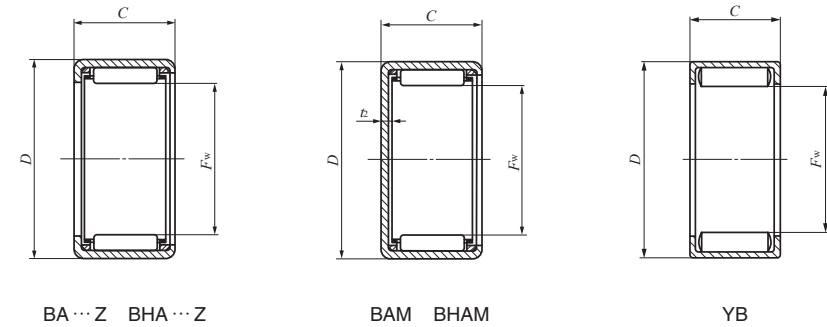
Inch Series



Shaft dia. 3.969 – 9.525mm

Shaft dia. mm (inch)	Identification number									
	Standard	Mass (Ref.) g	Closed end	Mass (Ref.) g	Standard	Mass (Ref.) g	Closed end	Mass (Ref.) g	Grease retained	Mass (Ref.) g
3.969 (5/32)	—	—	—	—	—	—	—	—	YB 2.5 2.5	0.64
	—	—	—	—	—	—	—	—	YB 2.5 4	0.96
4.762 (3/16)	—	—	—	—	—	—	—	—	YB 34	1.6
6.350 (1/4)	BA 44	2.1	—	—	—	—	—	—	—	—
	BA 45 Z	2.5	BAM 45	2.7	—	—	—	—	—	—
	BA 47 Z	3.5	BAM 47	3.7	—	—	—	—	—	—
	—	—	—	—	—	—	—	—	YB 45	3.2
—	—	—	—	—	—	—	—	—	YB 47	4.6
7.938 (5/16)	BA 55 Z	3	BAM 55	3.3	—	—	—	—	—	—
	BA 56 Z	3.6	BAM 56	3.9	—	—	—	—	—	—
	BA 57 Z	4.3	BAM 57	4.6	—	—	—	—	—	—
	BA 59 Z	5.4	BAM 59	5.7	—	—	—	—	—	—
	—	—	—	—	—	—	—	—	YB 55	3.8
—	—	—	—	BHA 57 Z	6.3	BHAM 57	6.6	—	—	—
9.525 (3/8)	BA 65 Z	3.5	BAM 65	3.9	—	—	—	—	—	—
	BA 66 Z	4.2	BAM 66	4.6	—	—	—	—	—	—
	BA 68 Z	5.7	BAM 68	6.1	—	—	—	—	—	—
	BA 69 Z	6.3	BAM 69	6.7	—	—	—	—	—	—
	BA 610 Z	7	BAM 610	7.4	—	—	—	—	—	—
	—	—	—	—	—	—	—	—	YB 64	3.4
	—	—	—	—	—	—	—	—	YB 66	5.3
	—	—	—	—	—	—	—	—	YB 68	7.2
—	—	—	—	—	—	—	—	YB 610	9.1	
—	—	—	—	BHA 68 Z	8.2	BHAM 68	8.6	—	—	—

Note(1) Allowable rotational speed applies to oil lubrication. For grease lubrication, a maximum of 60% of this value is allowable.
 Remark Shell Type Grease Retained Full Complement Needle Roller Bearings are provided with prepacked grease. Standard type and closed end type bearings are not provided with prepacked grease, so perform proper lubrication when using these types of bearings.



Boundary dimensions mm(inch)				Standard mounting dimensions mm				Basic dynamic load rating	Basic static load rating	Allowable rotational speed(1)	Assembled inner ring
F _w	D	C	t ₂ Max.	Shaft dia. h6		Housing bore dia. J7		C N	C ₀ N	min ⁻¹	
				Max.	Min.	Max.	Min.				
3.969 (5/32)	7.144 (9/32)	3.96(.156)	—	3.969	3.961	7.152	7.137	1 350	1 220	40 000	—
3.969 (5/32)	7.144 (9/32)	6.35(.250)	—	—	—	—	—	2 320	2 440	40 000	—
4.762 (3/16)	8.731 (11/32)	6.35(.250)	—	4.762	4.754	8.739	8.724	2 770	2 700	30 000	—
6.350 (1/4)	11.112 (7/16)	6.35(.250)	1	—	—	—	—	1 770	1 390	55 000	—
6.350 (1/4)	11.112 (7/16)	7.92(.312)	1	—	—	—	—	1 510	1 120	55 000	—
6.350 (1/4)	11.112 (7/16)	11.13(.438)	1	6.350	6.341	11.122	11.104	2 650	2 310	55 000	—
6.350 (1/4)	11.112 (7/16)	7.92(.312)	—	—	—	—	—	4 450	4 870	25 000	—
6.350 (1/4)	11.112 (7/16)	11.13(.438)	—	—	—	—	—	6 320	7 650	25 000	—
7.938 (5/16)	12.700 (1/2)	7.92(.312)	1	—	—	—	—	1 880	1 560	45 000	—
7.938 (5/16)	12.700 (1/2)	9.52(.375)	1	—	—	—	—	2 620	2 390	45 000	—
7.938 (5/16)	12.700 (1/2)	11.13(.438)	1	7.938	7.929	12.710	12.692	3 310	3 220	45 000	—
7.938 (5/16)	12.700 (1/2)	14.27(.562)	1	—	—	—	—	4 190	4 360	45 000	—
7.938 (5/16)	12.700 (1/2)	7.92(.312)	—	—	—	—	—	5 110	6 090	20 000	—
7.938 (5/16)	14.288 (9/16)	11.13(.438)	1.3	7.938	7.929	14.298	14.280	4 150	3 730	45 000	—
9.525 (3/8)	14.288 (9/16)	7.92(.312)	1	—	—	—	—	2 220	2 010	40 000	—
9.525 (3/8)	14.288 (9/16)	9.52(.375)	1	—	—	—	—	3 090	3 080	40 000	—
9.525 (3/8)	14.288 (9/16)	12.70(.500)	1	9.525	9.516	14.298	14.280	4 190	4 560	40 000	—
9.525 (3/8)	14.288 (9/16)	14.27(.562)	1	—	—	—	—	4 940	5 630	40 000	—
9.525 (3/8)	14.288 (9/16)	15.88(.625)	1	—	—	—	—	5 660	6 700	40 000	—
9.525 (3/8)	14.288 (9/16)	6.35(.250)	—	—	—	—	—	4 470	5 360	16 000	—
9.525 (3/8)	14.288 (9/16)	9.52(.375)	—	9.525	9.516	14.298	14.280	6 920	9 410	16 000	—
9.525 (3/8)	14.288 (9/16)	12.70(.500)	—	—	—	—	—	9 210	13 600	16 000	—
9.525 (3/8)	14.288 (9/16)	15.88(.625)	—	—	—	—	—	11 300	17 800	16 000	—
9.525 (3/8)	15.875 (5/8)	12.70(.500)	1.3	9.525	9.516	15.885	15.867	4 880	4 740	40 000	—

SHELL TYPE NEEDLE ROLLER BEARINGS

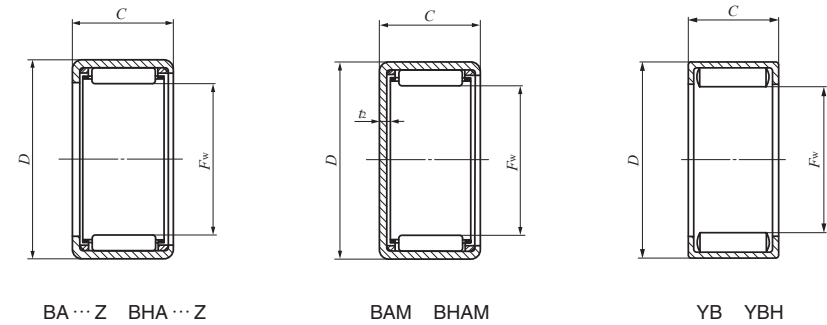
Inch Series



Shaft dia. 11.112 – 12.700mm

Shaft dia. mm (inch)	Identification number									
	Standard	Mass (Ref.) g	Closed end	Mass (Ref.) g	Standard	Mass (Ref.) g	Closed end	Mass (Ref.) g	Grease retained	Mass (Ref.) g
11.112 (7/16)	BA 76 Z	4.8	BAM 76	5.3	—	—	—	—	—	—
	BA 77 Z	5.6	BAM 77	6.2	—	—	—	—	—	—
	BA 78 Z	6.4	BAM 78	7	—	—	—	—	—	—
	BA 710 Z	7.9	BAM 710	8.5	—	—	—	—	—	—
	—	—	—	—	—	—	—	—	YB 78	8.2
	—	—	—	—	BHA 78 Z	9.3	BHAM 78	10	—	—
12.700 (1/2)	—	—	—	—	—	—	—	—	YBH 78	10.5
	BA 85 Z	4.4	BAM 85	5.2	—	—	—	—	—	—
	BA 86 Z	5.3	BAM 86	6.1	—	—	—	—	—	—
	BA 87 Z	6.3	BAM 87	7	—	—	—	—	—	—
	BA 88 Z	7.2	BAM 88	7.9	—	—	—	—	—	—
	BA 810 Z	8.9	BAM 810	9.6	—	—	—	—	—	—
	BA 812 Z	10.6	BAM 812	11.3	—	—	—	—	—	—
	—	—	—	—	—	—	—	—	YB 84	4.3
	—	—	—	—	—	—	—	—	YB 86	6.7
	—	—	—	—	—	—	—	—	YB 87	7.9
	—	—	—	—	—	—	—	—	YB 88	9.1
	—	—	—	—	—	—	—	—	YB 810	11.5
	—	—	—	—	—	—	—	—	YB 812	13.9
	—	—	—	—	BHA 87 Z	9.1	BHAM 87	9.9	—	—
	—	—	—	—	BHA 88 Z	10.4	BHAM 88	11.3	—	—
	—	—	—	—	BHA 810 Z	12.5	BHAM 810	13.3	—	—
	—	—	—	—	BHA 812 Z	15	BHAM 812	15.8	—	—
	—	—	—	—	—	—	—	—	YBH 810	16

Note(1) Allowable rotational speed applies to oil lubrication. For grease lubrication, a maximum of 60% of this value is allowable.
 Remark Shell Type Grease Retained Full Complement Needle Roller Bearings are provided with prepacked grease. Standard type and closed end type bearings are not provided with prepacked grease, so perform proper lubrication when using these types of bearings.



Boundary dimensions mm(inch)				Standard mounting dimensions mm				Basic dynamic load rating C	Basic static load rating C ₀	Allowable rotational speed ⁽¹⁾	Assembled inner ring
F _w	D	C	t ₂ Max.	Shaft dia. h6		Housing bore dia. J7					
				Max.	Min.	Max.	Min.	N	N	min ⁻¹	
11.112 (7/16)	15.875 (5/8)	9.52(.375)	1					3 290	3 470	35 000	—
11.112 (7/16)	15.875 (5/8)	11.13(.438)	1					4 150	4 680	35 000	—
11.112 (7/16)	15.875 (5/8)	12.70(.500)	1	11.112	11.101	15.885	15.867	4 460	5 130	35 000	—
11.112 (7/16)	15.875 (5/8)	15.88(.625)	1					6 020	7 550	35 000	—
11.112 (7/16)	15.875 (5/8)	12.70(.500)	—					10 100	15 900	14 000	—
11.112 (7/16)	17.462 (11/16)	12.70(.500)	1.3	11.112	11.101	17.472	17.454	5 680	5 970	35 000	—
11.112 (7/16)	17.462 (11/16)	12.70(.500)	—					12 500	15 800	14 000	—
12.700 (1/2)	17.462 (11/16)	7.92(.312)	1					2 490	2 510	30 000	—
12.700 (1/2)	17.462 (11/16)	9.52(.375)	1					3 470	3 850	30 000	—
12.700 (1/2)	17.462 (11/16)	11.13(.438)	1	12.700	12.689	17.472	17.454	4 380	5 190	30 000	—
12.700 (1/2)	17.462 (11/16)	12.70(.500)	1					4 710	5 700	30 000	IRB 58
12.700 (1/2)	17.462 (11/16)	15.88(.625)	1					6 350	8 380	30 000	—
12.700 (1/2)	17.462 (11/16)	19.05(.750)	1					7 840	11 000	30 000	—
12.700 (1/2)	17.462 (11/16)	6.35(.250)	—					5 260	7 150	12 000	—
12.700 (1/2)	17.462 (11/16)	9.52(.375)	—					8 150	12 600	12 000	—
12.700 (1/2)	17.462 (11/16)	11.13(.438)	—	12.700	12.689	17.472	17.454	9 530	15 300	12 000	—
12.700 (1/2)	17.462 (11/16)	12.70(.500)	—					10 800	18 100	12 000	IRB 58
12.700 (1/2)	17.462 (11/16)	15.88(.625)	—					13 400	23 700	12 000	—
12.700 (1/2)	17.462 (11/16)	19.05(.750)	—					15 800	29 300	12 000	—
12.700 (1/2)	19.050 (3/4)	11.13(.438)	1.3					5 670	6 120	30 000	—
12.700 (1/2)	19.050 (3/4)	12.70(.500)	1.3					6 040	6 650	30 000	IRB 58
12.700 (1/2)	19.050 (3/4)	15.88(.625)	1.3	12.700	12.689	19.062	19.041	8 830	10 900	30 000	—
12.700 (1/2)	19.050 (3/4)	19.05(.750)	1.3					11 100	14 500	30 000	—
12.700 (1/2)	19.050 (3/4)	15.88(.625)	—					16 300	23 500	12 000	—

SHELL TYPE NEEDLE ROLLER BEARINGS

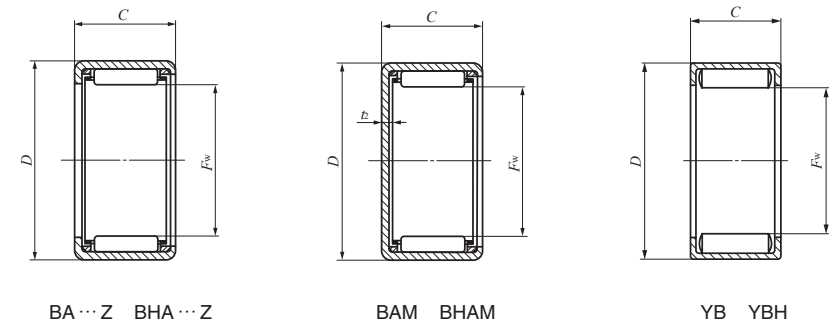
Inch Series



Shaft dia. 14.288 — 15.875mm

Shaft dia. mm (inch)	Identification number									
	Standard	Mass (Ref.) g	Closed end	Mass (Ref.) g	Standard	Mass (Ref.) g	Closed end	Mass (Ref.) g	Grease retained	Mass (Ref.) g
14.288 (9/16)	BA 95 Z	4.9	BAM 95	5.8	—	—	—	—	—	—
	BA 96 Z	5.9	BAM 96	6.8	—	—	—	—	—	—
	BA 97 Z	6.9	BAM 97	7.8	—	—	—	—	—	—
	BA 98 Z	7.9	BAM 98	8.9	—	—	—	—	—	—
	BA 910 Z	9.9	BAM 910	10.8	—	—	—	—	—	—
	BA 912 Z	11.7	BAM 912	12.6	—	—	—	—	—	—
	—	—	—	—	—	—	—	—	YB 98	10.1
	—	—	—	—	—	—	—	—	YB 910	12.7
	—	—	—	—	—	—	—	—	YB 912	15.4
	—	—	—	—	BHA 98 Z	11.4	BHAM 98	12.5	—	—
—	—	—	—	BHA 910 Z	13.6	BHAM 910	14.7	—	—	
—	—	—	—	BHA 912 Z	16.3	BHAM 912	17.4	—	—	
15.875 (5/8)	BA 105 Z	5.3	BAM 105	6.5	—	—	—	—	—	—
	BA 107 Z	7.6	BAM 107	8.7	—	—	—	—	—	—
	BA 108 Z	8.7	BAM 108	9.9	—	—	—	—	—	—
	BA 1010 Z	10.8	BAM 1010	12	—	—	—	—	—	—
	BA 1012 Z	12.9	BAM 1012	14	—	—	—	—	—	—
	BA 1014 Z	15.1	BAM 1014	16.2	—	—	—	—	—	—
	BA 1016 Z	17.3	BAM 1016	18.4	—	—	—	—	—	—
	—	—	—	—	—	—	—	—	YB 105	6.7
	—	—	—	—	—	—	—	—	YB 108	11
	—	—	—	—	—	—	—	—	YB 1012	16.9
—	—	—	—	BHA 108 Z	12.6	BHAM 108	13.9	—	—	
—	—	—	—	BHA 1010 Z	14.9	BHAM 1010	16.2	—	—	
—	—	—	—	BHA 1012 Z	18	BHAM 1012	19.3	—	—	
—	—	—	—	BHA 1016 Z	24	BHAM 1016	25	—	—	
—	—	—	—	—	—	—	—	YBH 108	15.3	

Note(1) Allowable rotational speed applies to oil lubrication. For grease lubrication, a maximum of 60% of this value is allowable.
 Remark Shell Type Grease Retained Full Complement Needle Roller Bearings are provided with prepacked grease. Standard type and closed end type bearings are not provided with prepacked grease, so perform proper lubrication when using these types of bearings.



Boundary dimensions mm(inch)				Standard mounting dimensions mm				Basic dynamic load rating	Basic static load rating	Allowable rotational speed(1)	Assembled inner ring
F _w	D	C	t ₂ Max.	Shaft dia. h6		Housing bore dia. J7		C	C ₀	min ⁻¹	
				Max.	Min.	Max.	Min.	N	N	min ⁻¹	
14.288 (9/16)	19.050 (3/4)	7.92 (.312)	1.3					2 760	2 970	30 000	—
14.288 (9/16)	19.050 (3/4)	9.52 (.375)	1.3					3 850	4 560	30 000	—
14.288 (9/16)	19.050 (3/4)	11.13 (.438)	1.3					4 860	6 140	30 000	—
14.288 (9/16)	19.050 (3/4)	12.70 (.500)	1.3					5 220	6 740	30 000	IRB 68
14.288 (9/16)	19.050 (3/4)	15.88 (.625)	1.3	14.288	14.277	19.062	19.041	7 050	9 910	30 000	—
14.288 (9/16)	19.050 (3/4)	19.05 (.750)	1.3					8 690	13 000	30 000	IRB 612
14.288 (9/16)	19.050 (3/4)	12.70 (.500)	—					11 600	20 400	11 000	IRB 68
14.288 (9/16)	19.050 (3/4)	15.88 (.625)	—					14 300	26 700	11 000	—
14.288 (9/16)	19.050 (3/4)	19.05 (.750)	—					16 800	33 000	11 000	IRB 612
14.288 (9/16)	20.638 (13/16)	12.70 (.500)	1.3					6 380	7 330	30 000	IRB 68
14.288 (9/16)	20.638 (13/16)	15.88 (.625)	1.3	14.288	14.277	20.650	20.629	9 280	11 900	30 000	—
14.288 (9/16)	20.638 (13/16)	19.05 (.750)	1.3					11 600	15 900	30 000	IRB 612
15.875 (5/8)	20.638 (13/16)	7.92 (.312)	1.3					2 870	3 220	25 000	—
15.875 (5/8)	20.638 (13/16)	11.13 (.438)	1.3					5 040	6 660	25 000	—
15.875 (5/8)	20.638 (13/16)	12.70 (.500)	1.3					5 420	7 310	25 000	IRB 68-1
15.875 (5/8)	20.638 (13/16)	15.88 (.625)	1.3					7 320	10 700	25 000	—
15.875 (5/8)	20.638 (13/16)	19.05 (.750)	1.3	15.875	15.864	20.650	20.629	9 020	14 100	25 000	IRB 612-1
15.875 (5/8)	20.638 (13/16)	22.22 (.875)	1.3					10 700	17 500	25 000	IRB 714
15.875 (5/8)	20.638 (13/16)	25.40 (1.000)	1.3					12 300	20 800	25 000	IRB 716
15.875 (5/8)	20.638 (13/16)	7.92 (.312)	—					7 580	12 200	9 500	—
15.875 (5/8)	20.638 (13/16)	12.70 (.500)	—					12 300	22 700	9 500	IRB 68-1
15.875 (5/8)	20.638 (13/16)	19.05 (.750)	—					17 800	36 600	9 500	IRB 612-1
15.875 (5/8)	22.225 (7/8)	12.70 (.500)	1.3					6 680	8 020	25 000	IRB 68-1
15.875 (5/8)	22.225 (7/8)	15.88 (.625)	1.3					10 200	13 800	25 000	—
15.875 (5/8)	22.225 (7/8)	19.05 (.750)	1.3	15.875	15.864	22.237	22.216	12 700	18 500	25 000	IRB 612-1
15.875 (5/8)	22.225 (7/8)	25.40 (1.000)	1.3					17 400	27 600	25 000	IRB 716
15.875 (5/8)	22.225 (7/8)	12.70 (.500)	—					15 000	22 400	9 500	IRB 68-1

SHELL TYPE NEEDLE ROLLER BEARINGS

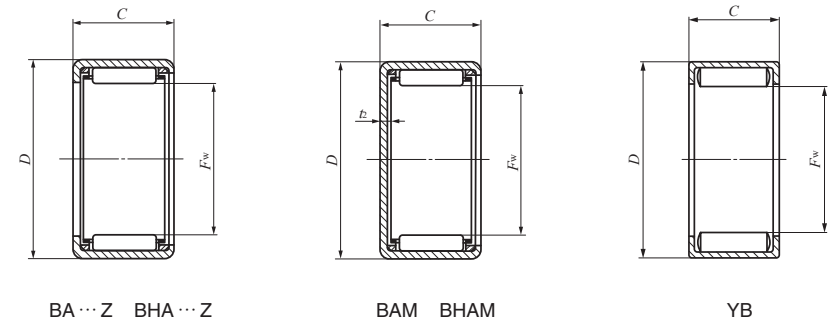
Inch Series



Shaft dia. 17.462 – 19.050mm

Shaft dia. mm (inch)	Identification number									
	Standard	Mass (Ref.) g	Closed end	Mass (Ref.) g	Standard	Mass (Ref.) g	Closed end	Mass (Ref.) g	Grease retained	Mass (Ref.) g
17.462 (11/16)	BA 116 Z	7	BAM 116	8.4	—	—	—	—	—	—
	BA 118 Z	9.5	BAM 118	10.8	—	—	—	—	—	—
	BA 1110 Z	11.8	BAM 1110	13.2	—	—	—	—	—	—
	BA 1112 Z	14	BAM 1112	15.4	—	—	—	—	—	—
	—	—	—	—	—	—	—	—	YB 1112	18.3
	—	—	—	—	BHA 117 Z	11.9	BHAM 117	13.5	—	—
	—	—	—	—	BHA 118 Z	13.7	BHAM 118	15.3	—	—
	—	—	—	—	BHA 1110 Z	16	BHAM 1110	17.6	—	—
	—	—	—	—	BHA 1112 Z	19.3	BHAM 1112	21	—	—
	19.050 (3/4)	BA 126 Z	10	BAM 126	11.7	—	—	—	—	—
BA 128 Z		13.5	BAM 128	15.2	—	—	—	—	—	—
BA 1210 Z		17	BAM 1210	18.6	—	—	—	—	—	—
BA 1212 Z		20.5	BAM 1212	22	—	—	—	—	—	—
BA 1214 Z		23.5	BAM 1214	25	—	—	—	—	—	—
BA 1216 Z		27	BAM 1216	28.5	—	—	—	—	—	—
—		—	—	—	—	—	—	—	YB 124	8.5
—		—	—	—	—	—	—	—	YB 128	17.8
—		—	—	—	—	—	—	—	YB 1210	22.5
—		—	—	—	—	—	—	—	YB 1212	27
—		—	—	—	BHA 1212 Z	26.5	BHAM 1212	28.5	—	—

Note(1) Allowable rotational speed applies to oil lubrication. For grease lubrication, a maximum of 60% of this value is allowable.
 Remark Shell Type Grease Retained Full Complement Needle Roller Bearings are provided with prepacked grease. Standard type and closed end type bearings are not provided with prepacked grease, so perform proper lubrication when using these types of bearings.



Boundary dimensions mm(inch)				Standard mounting dimensions mm				Basic dynamic load rating C N	Basic static load rating C ₀ N	Allowable rotational speed ⁽¹⁾ min ⁻¹	Assembled inner ring				
F _w	D	C	t ₂ Max.	Shaft dia. h6		Housing bore dia. J7									
				Max.	Min.	Max.	Min.								
17.462 (11/16)	22.225 (7/8)	9.52 (.375)	1.3	17.462	17.451	22.237	22.216	4 530	5 980	25 000	IRB 86				
17.462 (11/16)	22.225 (7/8)	12.70 (.500)	1.3					6 140	8 850	25 000	IRB 88				
17.462 (11/16)	22.225 (7/8)	15.88 (.625)	1.3					8 280	13 000	25 000	—				
17.462 (11/16)	22.225 (7/8)	19.05 (.750)	1.3					10 200	17 000	25 000	IRB 812				
17.462 (11/16)	22.225 (7/8)	19.05 (.750)	—					18 700	40 300	8 500	IRB 812				
17.462 (11/16)	23.812 (15/16)	11.13 (.438)	1.3					17.462	17.451	23.824	23.803	6 860	8 530	25 000	—
17.462 (11/16)	23.812 (15/16)	12.70 (.500)	1.3	7 320	9 270	25 000	IRB 88								
17.462 (11/16)	23.812 (15/16)	15.88 (.625)	1.3	10 500	14 900	25 000	—								
17.462 (11/16)	23.812 (15/16)	19.05 (.750)	1.3	13 200	19 900	25 000	IRB 812								
19.050 (3/4)	25.400 (1)	9.52 (.375)	1.3	19.050	19.037	25.412	25.391					5 040	5 850	20 000	—
19.050 (3/4)	25.400 (1)	12.70 (.500)	1.3									6 910	8 780	20 000	IRB 88-1
19.050 (3/4)	25.400 (1)	15.88 (.625)	1.3					9 500	13 200	20 000	IRB 810-1				
19.050 (3/4)	25.400 (1)	19.05 (.750)	1.3					11 900	17 700	20 000	IRB 812-1				
19.050 (3/4)	25.400 (1)	22.22 (.875)	1.3					14 200	22 200	20 000	IRB 814-1				
19.050 (3/4)	25.400 (1)	25.40 (1.000)	1.3					16 300	26 500	20 000	IRB 816-1				
19.050 (3/4)	25.400 (1)	6.35 (.250)	—					19.050	19.037	25.412	25.391	7 820	10 200	8 000	—
19.050 (3/4)	25.400 (1)	12.70 (.500)	—									16 600	26 900	8 000	IRB 88-1
19.050 (3/4)	25.400 (1)	15.88 (.625)	—	20 500	35 300	8 000	IRB 810-1								
19.050 (3/4)	25.400 (1)	19.05 (.750)	—	24 100	43 400	8 000	IRB 812-1								
19.050 (3/4)	26.988 (1 1/16)	19.05 (.750)	1.3	19.050	19.037	27.000	26.979	16 600	22 600	20 000	IRB 812-1				

SHELL TYPE NEEDLE ROLLER BEARINGS

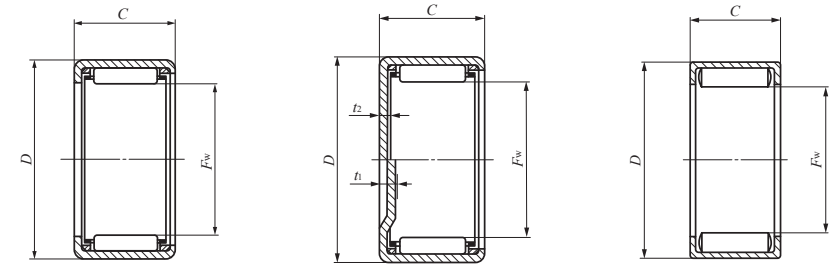
Inch Series



Shaft dia. 20.638 — 22.225mm

Shaft dia. mm (inch)	Identification number									
	Standard	Mass (Ref.) g	Closed end	Mass (Ref.) g	Standard	Mass (Ref.) g	Closed end	Mass (Ref.) g	Grease retained	Mass (Ref.) g
20.638 (13/16)	BA 136 Z	10.7	BAM 136	12.6	—	—	—	—	—	—
	BA 138 Z	14.5	BAM 138	16.4	—	—	—	—	—	—
	BA 1310 Z	18.2	BAM 1310	20	—	—	—	—	—	—
	BA 1312 Z	22	BAM 1312	23.5	—	—	—	—	—	—
	BA 1314 Z	25	BAM 1314	27	—	—	—	—	—	—
	BA 1316 Z	28.5	BAM 1316	30.5	—	—	—	—	—	—
	BA 1320 Z	35.5	BAM 1320	37.5	—	—	—	—	—	—
	—	—	—	—	—	—	—	—	YB 136	14.1
	—	—	—	—	—	—	—	—	YB 138	19.1
	—	—	—	—	BHA 138 Z	20	BHAM 138	22.5	—	—
	—	—	—	—	BHA 1310 Z	23.5	BHAM 1310	25.5	—	—
	—	—	—	—	BHA 1312 Z	28.5	BHAM 1312	30.5	—	—
	—	—	—	—	—	—	—	—	YBH 1310	30.5
	—	—	—	—	—	—	—	—	YBH 1312	37
22.225 (7/8)	BA 146 Z	11.5	BAM 146	13.8	—	—	—	—	—	—
	BA 148 Z	15.6	BAM 148	17.8	—	—	—	—	—	—
	BA 1412 Z	23.5	BAM 1412	26	—	—	—	—	—	—
	BA 1414 Z	27	BAM 1414	29.5	—	—	—	—	—	—
	BA 1416 Z	31	BAM 1416	33.5	—	—	—	—	—	—
	BA 1418 Z	34.5	BAM 1418	37	—	—	—	—	—	—
	BA 1422 Z	42.5	BAM 1422	44.5	—	—	—	—	—	—
	—	—	—	—	—	—	—	—	YB 148	20.5
	—	—	—	—	—	—	—	—	YB 1412	31
	—	—	—	—	—	—	—	—	YB 1416	41.5
	—	—	—	—	BHA 1410 Z	25	BHAM 1410	27.5	—	—
	—	—	—	—	BHA 1412 Z	30	BHAM 1412	32.5	—	—
	—	—	—	—	BHA 1416 Z	39.5	BHAM 1416	42	—	—
	—	—	—	—	—	—	—	—	YBH 1412	39

Note(1) Allowable rotational speed applies to oil lubrication. For grease lubrication, a maximum of 60% of this value is allowable.
 Remark Shell Type Grease Retained Full Complement Needle Roller Bearings are provided with prepacked grease. Standard type and closed end type bearings are not provided with prepacked grease, so perform proper lubrication when using these types of bearings.



BA...Z BHA...Z

BAM BHAM
 $t_1 (F_w \geq 22.225)$
 $t_2 (F_w \leq 20.638)$

YB YBH

Boundary dimensions mm(inch)				Standard mounting dimensions mm				Basic dynamic load rating C N	Basic static load rating C ₀ N	Allowable rotational speed ⁽¹⁾ min ⁻¹	Assembled inner ring				
F _w	D	C	t ₁ t ₂ Max.	Shaft dia. h6 Max. Min.		Housing bore dia. J7 Max. Min.									
20.638 (13/16)	26.988 (1 1/16)	9.52 (.375)	1.3	20.638	20.625	27.000	26.979	5 230	6 300	19 000	—				
20.638 (13/16)	26.988 (1 1/16)	12.70 (.500)	1.3					13 800	18 200	19 000	IRB 98				
20.638 (13/16)	26.988 (1 1/16)	15.88 (.625)	1.3					17 300	24 400	19 000	IRB 910				
20.638 (13/16)	26.988 (1 1/16)	19.05 (.750)	1.3					22 900	36 300	19 000	IRB 912				
20.638 (13/16)	26.988 (1 1/16)	22.22 (.875)	1.3					27 200	45 300	19 000	IRB 914				
20.638 (13/16)	26.988 (1 1/16)	25.40 (1.000)	1.3					—	—	19 000	IRB 916				
20.638 (13/16)	26.988 (1 1/16)	31.75 (1.250)	1.3					—	—	19 000	IRB 920				
20.638 (13/16)	26.988 (1 1/16)	9.52 (.375)	—					—	—	7 500	—				
20.638 (13/16)	26.988 (1 1/16)	12.70 (.500)	—					—	—	7 500	IRB 98				
20.638 (13/16)	28.575 (1 1/8)	12.70 (.500)	1.3					20.638	20.625	28.587	28.566	9 500	11 200	19 000	IRB 98
20.638 (13/16)	28.575 (1 1/8)	15.88 (.625)	1.3									13 800	18 200	19 000	IRB 910
20.638 (13/16)	28.575 (1 1/8)	19.05 (.750)	1.3									17 300	24 400	19 000	IRB 912
20.638 (13/16)	28.575 (1 1/8)	15.88 (.625)	—									22 900	36 300	7 500	IRB 910
20.638 (13/16)	28.575 (1 1/8)	19.05 (.750)	—									27 200	45 300	7 500	IRB 912
20.638 (13/16)	28.575 (1 1/8)	9.52 (.375)	2.8	22.225	22.212	28.587	28.566					5 430	6 740	18 000	IRB 106
22.225 (7/8)	28.575 (1 1/8)	12.70 (.500)	2.8					7 440	10 100	18 000	IRB 108				
22.225 (7/8)	28.575 (1 1/8)	19.05 (.750)	2.8					12 800	20 400	18 000	IRB 1012				
22.225 (7/8)	28.575 (1 1/8)	22.22 (.875)	2.8					15 300	25 500	18 000	IRB 1014				
22.225 (7/8)	28.575 (1 1/8)	25.40 (1.000)	2.8					17 600	30 500	18 000	IRB 1016				
22.225 (7/8)	28.575 (1 1/8)	28.58 (1.125)	2.8					19 800	35 600	18 000	—				
22.225 (7/8)	28.575 (1 1/8)	34.92 (1.375)	2.8					24 100	45 700	18 000	IRB 1022				
22.225 (7/8)	28.575 (1 1/8)	12.70 (.500)	—					18 100	31 400	7 000	IRB 108				
22.225 (7/8)	28.575 (1 1/8)	19.05 (.750)	—					26 300	50 700	7 000	IRB 1012				
22.225 (7/8)	28.575 (1 1/8)	25.40 (1.000)	—					33 800	70 200	7 000	IRB 1016				
22.225 (7/8)	30.162 (1 3/16)	15.88 (.625)	3.4					22.225	22.212	30.176	30.151	14 300	19 500	18 000	—
22.225 (7/8)	30.162 (1 3/16)	19.05 (.750)	3.4									18 000	26 100	18 000	IRB 1012
22.225 (7/8)	30.162 (1 3/16)	25.40 (1.000)	3.4									23 600	36 900	18 000	IRB 1016
22.225 (7/8)	30.162 (1 3/16)	19.05 (.750)	—									28 200	49 000	7 000	IRB 1012
22.225 (7/8)	30.162 (1 3/16)	9.52 (.375)	—	—	—	—	—								

SHELL TYPE NEEDLE ROLLER BEARINGS

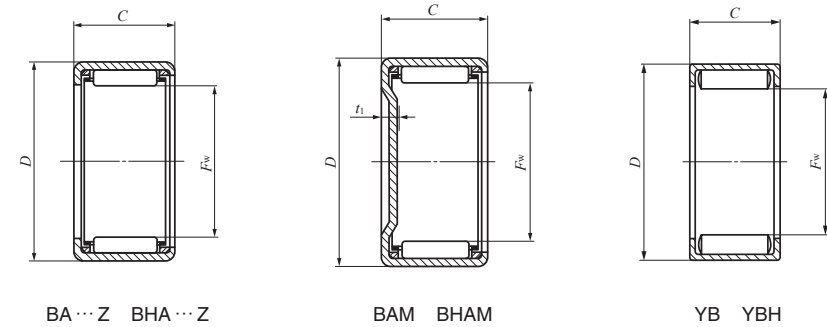
Inch Series



Shaft dia. 23.812 – 26.988mm

Shaft dia. mm (inch)	Identification number									
	Standard	Mass (Ref.) g	Closed end	Mass (Ref.) g	Standard	Mass (Ref.) g	Closed end	Mass (Ref.) g	Grease retained	Mass (Ref.) g
23.812 (15/16)	BA 158 Z	16.5	BAM 158	19	—	—	—	—	—	—
	BA 1510 Z	20.5	BAM 1510	23	—	—	—	—	—	—
	BA 1516 Z	33	BAM 1516	35.5	—	—	—	—	—	—
25.400 (1)	BA 166 Z	13.1	BAM 166	16	—	—	—	—	—	—
	BA 167 Z	15.4	BAM 167	18.3	—	—	—	—	—	—
	BA 168 Z	17.7	BAM 168	20.5	—	—	—	—	—	—
	BA 1610 Z	22	BAM 1610	25	—	—	—	—	—	—
	BA 1612 Z	26.5	BAM 1612	29.5	—	—	—	—	—	—
	BA 1614 Z	31	BAM 1614	33.5	—	—	—	—	—	—
	BA 1616 Z	35.5	BAM 1616	38	—	—	—	—	—	—
	BA 1620 Z	44	BAM 1620	46.5	—	—	—	—	—	—
	—	—	—	—	—	—	—	—	YB 168	23
	—	—	—	—	—	—	—	—	YB 1612	34.5
	—	—	—	—	—	—	—	—	YB 1616	46.5
	—	—	—	—	BHA 168 Z	24	BHAM 168	27	—	—
	—	—	—	—	BHA 1610 Z	28	BHAM 1610	31	—	—
	—	—	—	—	BHA 1612 Z	33.5	BHAM 1612	37	—	—
	—	—	—	—	BHA 1614 Z	39.5	BHAM 1614	42.5	—	—
—	—	—	—	BHA 1616 Z	45	BHAM 1616	48	—	—	
—	—	—	—	BHA 1620 Z	56.5	BHAM 1620	59.5	—	—	
—	—	—	—	BHA 1624 Z	67.5	BHAM 1624	71	—	—	
—	—	—	—	—	—	—	—	YBH 168	29	
—	—	—	—	—	—	—	—	YBH 1612	44.5	
—	—	—	—	—	—	—	—	YBH 1616	59.5	
26.988 (1 1/16)	BA 1710 Z	23.5	BAM 1710	26.5	—	—	—	—	—	
	BA 1716 Z	37	BAM 1716	40.5	—	—	—	—	—	

Note(1) Allowable rotational speed applies to oil lubrication. For grease lubrication, a maximum of 60% of this value is allowable.
 Remark Shell Type Grease Retained Full Complement Needle Roller Bearings are provided with prepacked grease. Standard type and closed end type bearings are not provided with prepacked grease, so perform proper lubrication when using these types of bearings.



Boundary dimensions mm(inch)				Standard mounting dimensions mm				Basic dynamic load rating C N	Basic static load rating C ₀ N	Allowable rotational speed ⁽¹⁾ min ⁻¹	Assembled inner ring				
F _w	D	C	t ₁ Max.	Shaft dia. h6 Max. Min.		Housing bore dia. J7 Max. Min.									
23.812 (15/16)	30.162 (1 3/16)	12.70 (.500)	2.8	23.812	23.799	30.176	30.151	8 000	11 400	16 000	—				
23.812 (15/16)	30.162 (1 3/16)	15.88 (.625)	2.8					11 000	17 100	16 000	IRB 1110				
23.812 (15/16)	30.162 (1 3/16)	25.40(1.000)	2.8					18 900	34 300	16 000	IRB 1116				
25.400 (1)	31.750 (1 1/4)	9.52 (.375)	2.8	25.400	25.387	31.764	31.739	6 010	8 020	15 000	—				
25.400 (1)	31.750 (1 1/4)	11.13 (.438)	2.8					7 720	11 100	15 000	—				
25.400 (1)	31.750 (1 1/4)	12.70 (.500)	2.8					8 240	12 000	15 000	IRB 128				
25.400 (1)	31.750 (1 1/4)	15.88 (.625)	2.8					11 300	18 100	15 000	—				
25.400 (1)	31.750 (1 1/4)	19.05 (.750)	2.8					14 200	24 300	15 000	IRB 1212				
25.400 (1)	31.750 (1 1/4)	22.22 (.875)	2.8					16 900	30 400	15 000	IRB 1214				
25.400 (1)	31.750 (1 1/4)	25.40(1.000)	2.8					19 400	36 300	15 000	IRB 1216				
25.400 (1)	31.750 (1 1/4)	31.75(1.250)	2.8					24 400	48 500	15 000	IRB 1220				
25.400 (1)	31.750 (1 1/4)	12.70 (.500)	—					19 400	36 000	6 000	IRB 128				
25.400 (1)	31.750 (1 1/4)	19.05 (.750)	—					28 200	58 000	6 000	IRB 1212				
25.400 (1)	31.750 (1 1/4)	25.40(1.000)	—					36 300	80 300	6 000	IRB 1216				
25.400 (1)	33.338 (1 5/16)	12.70 (.500)	3.4					25.400	25.387	33.352	33.327	10 200	13 100	15 000	IRB 128
25.400 (1)	33.338 (1 5/16)	15.88 (.625)	3.4									15 300	22 100	15 000	—
25.400 (1)	33.338 (1 5/16)	19.05 (.750)	3.4									19 300	29 700	15 000	IRB 1212
25.400 (1)	33.338 (1 5/16)	22.22 (.875)	3.4									23 000	37 200	15 000	IRB 1214
25.400 (1)	33.338 (1 5/16)	25.40(1.000)	3.4	26 400	44 500	15 000	IRB 1216								
25.400 (1)	33.338 (1 5/16)	31.75(1.250)	3.4	33 200	59 600	15 000	IRB 1220								
25.400 (1)	33.338 (1 5/16)	38.10(1.500)	3.4	39 400	74 400	15 000	—								
25.400 (1)	33.338 (1 5/16)	12.70 (.500)	—	20 900	34 100	6 000	IRB 128								
25.400 (1)	33.338 (1 5/16)	19.05 (.750)	—	30 700	56 100	6 000	IRB 1212								
25.400 (1)	33.338 (1 5/16)	25.40(1.000)	—	39 900	78 400	6 000	IRB 1216								
26.988 (1 1/16)	33.338 (1 5/16)	15.88 (.625)	2.8	26.988	26.975	33.352	33.327					11 600	19 200	14 000	—
26.988 (1 1/16)	33.338 (1 5/16)	25.40(1.000)	2.8									20 000	38 300	14 000	—

SHELL TYPE NEEDLE ROLLER BEARINGS

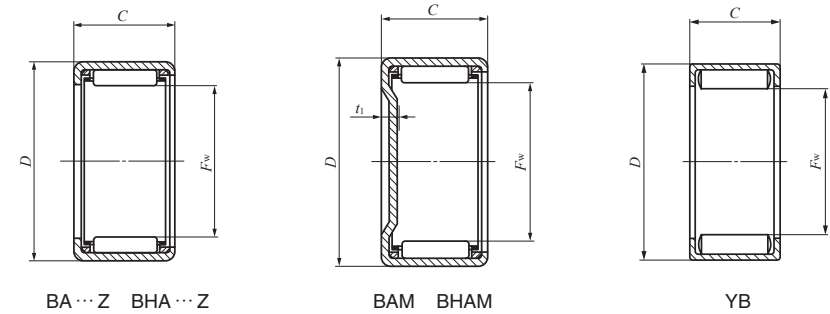
Inch Series



Shaft dia. 28.575 – 30.162mm

Shaft dia. mm (inch)	Identification number									
	Standard	Mass (Ref.) g	Closed end	Mass (Ref.) g	Standard	Mass (Ref.) g	Closed end	Mass (Ref.) g	Grease retained	Mass (Ref.) g
28.575 (1 1/8)	BA 186 Z	14.5	BAM 186	18.1	—	—	—	—	—	—
	BA 188 Z	19.5	BAM 188	23	—	—	—	—	—	—
	BA 1812 Z	29.5	BAM 1812	33	—	—	—	—	—	—
	BA 1816 Z	39	BAM 1816	42.5	—	—	—	—	—	—
	BA 1820 Z	48.5	BAM 1820	52	—	—	—	—	—	—
	—	—	—	—	—	—	—	—	YB 188	25.5
	—	—	—	—	—	—	—	—	YB 1812	38.5
	—	—	—	—	—	—	—	—	YB 1816	51.5
	—	—	—	—	BHA 1812 Z	45	BHAM 1812	49	—	—
	—	—	—	—	BHA 1816 Z	60	BHAM 1816	64	—	—
—	—	—	—	BHA 1818 Z	67.5	BHAM 1818	71.5	—	—	
—	—	—	—	BHA 1820 Z	73.5	BHAM 1820	78	—	—	
30.162 (1 3/16)	BA 1910 Z	32.5	BAM 1910	37.5	—	—	—	—	—	—
	BA 1916 Z	52	BAM 1916	57	—	—	—	—	—	
	—	—	—	—	—	—	—	—	YB 1910	42.5

Note(1) Allowable rotational speed applies to oil lubrication. For grease lubrication, a maximum of 60% of this value is allowable.
 Remark Shell Type Grease Retained Full Complement Needle Roller Bearings are provided with prepacked grease. Standard type and closed end type bearings are not provided with prepacked grease, so perform proper lubrication when using these types of bearings.



Boundary dimensions mm(inch)				Standard mounting dimensions mm				Basic dynamic load rating C N	Basic static load rating C ₀ N	Allowable rotational speed ⁽¹⁾ min ⁻¹	Assembled inner ring
F _w	D	C	t ₁ Max.	Shaft dia. h6		Housing bore dia. J7					
				Max.	Min.	Max.	Min.				
28.575 (1 1/8)	34.925 (1 3/8)	9.52 (.375)	2.8					6 330	8 910	13 000	—
28.575 (1 1/8)	34.925 (1 3/8)	12.70 (.500)	2.8					8 680	13 400	13 000	IRB 148
28.575 (1 1/8)	34.925 (1 3/8)	19.05 (.750)	2.8					15 000	26 900	13 000	IRB 1412
28.575 (1 1/8)	34.925 (1 3/8)	25.40(1.000)	2.8	28.575	28.562	34.939	34.914	20 500	40 300	13 000	IRB 1416
28.575 (1 1/8)	34.925 (1 3/8)	31.75(1.250)	2.8					25 700	53 900	13 000	IRB 1420
28.575 (1 1/8)	34.925 (1 3/8)	12.70 (.500)	—					20 700	40 500	5 500	IRB 148
28.575 (1 1/8)	34.925 (1 3/8)	19.05 (.750)	—					30 000	65 300	5 500	IRB 1412
28.575 (1 1/8)	34.925 (1 3/8)	25.40(1.000)	—					38 700	90 400	5 500	IRB 1416
28.575 (1 1/8)	38.100 (1 1/2)	19.05 (.750)	3.4					22 500	32 200	13 000	IRB 1412
28.575 (1 1/8)	38.100 (1 1/2)	25.40(1.000)	3.4	28.575	28.562	38.114	38.089	30 900	48 600	13 000	IRB 1416
28.575 (1 1/8)	38.100 (1 1/2)	28.58(1.125)	3.4					34 900	56 600	13 000	—
28.575 (1 1/8)	38.100 (1 1/2)	31.75(1.250)	3.4					37 100	61 100	13 000	IRB 1420
30.162 (1 3/16)	38.100 (1 1/2)	15.88 (.625)	2.8					15 000	22 500	12 000	—
30.162 (1 3/16)	38.100 (1 1/2)	25.40(1.000)	2.8	30.162	30.146	38.114	38.089	25 800	45 300	12 000	—
30.162 (1 3/16)	38.100 (1 1/2)	15.88 (.625)	—					28 400	53 600	5 000	—

SHELL TYPE NEEDLE ROLLER BEARINGS

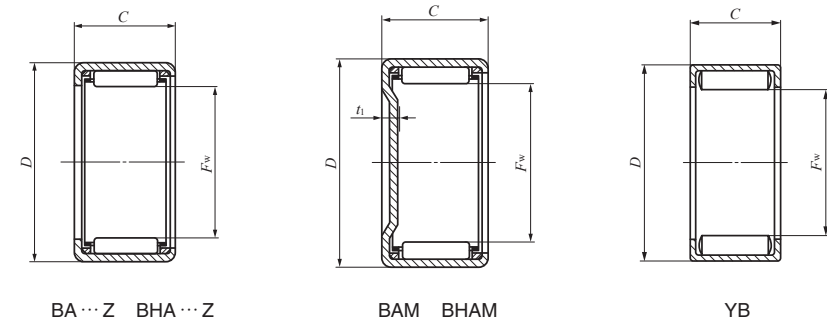
Inch Series



Shaft dia. 31.750 — 33.338mm

Shaft dia. mm (inch)	Identification number									
	Standard	Mass (Ref.) g	Closed end	Mass (Ref.) g	Standard	Mass (Ref.) g	Closed end	Mass (Ref.) g	Grease retained	Mass (Ref.) g
31.750 (1 1/4)	BA 208 Z	21.5	BAM 208	26	—	—	—	—	—	—
	BA 210 Z	27	BAM 210	31.5	—	—	—	—	—	—
	BA 212 Z	32.5	BAM 212	37	—	—	—	—	—	—
	BA 216 Z	43	BAM 216	47.5	—	—	—	—	—	—
	BA 220 Z	53.5	BAM 220	58	—	—	—	—	—	—
	—	—	—	—	—	—	—	—	YB 2010	35
	—	—	—	—	—	—	—	—	YB 2012	42.5
	—	—	—	—	—	—	—	—	YB 2016	57
	—	—	—	—	—	—	—	—	YB 2018	64
	—	—	—	—	—	—	—	—	YB 2020	68
	—	—	—	—	BHA 208 Z	34.5	BHAM 208	40	—	—
	—	—	—	—	BHA 212 Z	49.5	BHAM 212	54.5	—	—
	—	—	—	—	BHA 216 Z	66	BHAM 216	71	—	—
	—	—	—	—	BHA 220 Z	81.5	BHAM 220	86.5	—	—
33.338 (1 5/16)	BA 218 Z	28.5	BAM 218	35	—	—	—	—	—	
	BA 2110 Z	35.5	BAM 2110	41.5	—	—	—	—	—	
	BA 2112 Z	43	BAM 2112	49	—	—	—	—	—	

Note(1) Allowable rotational speed applies to oil lubrication. For grease lubrication, a maximum of 60% of this value is allowable.
 Remark Shell Type Grease Retained Full Complement Needle Roller Bearings are provided with prepacked grease. Standard type and closed end type bearings are not provided with prepacked grease, so perform proper lubrication when using these types of bearings.



Boundary dimensions mm(inch)				Standard mounting dimensions mm				Basic dynamic load rating C	Basic static load rating C ₀	Allowable rotational speed ⁽¹⁾	Assembled inner ring
F _w	D	C	t ₁ Max.	Shaft dia. h6		Housing bore dia. J7					
				Max.	Min.	Max.	Min.	N	N	min ⁻¹	
31.750 (1 1/4)	38.100 (1 1/2)	12.70 (.500)	2.8					9 100	14 700	12 000	IRB 168
31.750 (1 1/4)	38.100 (1 1/2)	15.88 (.625)	2.8					12 500	22 200	12 000	IRB 1610
31.750 (1 1/4)	38.100 (1 1/2)	19.05 (.750)	2.8	31.750	31.734	38.114	38.089	15 700	29 600	12 000	IRB 1612
31.750 (1 1/4)	38.100 (1 1/2)	25.40 (1.000)	2.8					21 500	44 300	12 000	IRB 1616
31.750 (1 1/4)	38.100 (1 1/2)	31.75 (1.250)	2.8					26 900	59 200	12 000	IRB 1620
31.750 (1 1/4)	38.100 (1 1/2)	15.88 (.625)	—					27 000	59 000	4 500	IRB 1610
31.750 (1 1/4)	38.100 (1 1/2)	19.05 (.750)	—					31 800	72 500	4 500	IRB 1612
31.750 (1 1/4)	38.100 (1 1/2)	25.40 (1.000)	—	31.750	31.734	38.114	38.089	40 900	100 000	4 500	IRB 1616
31.750 (1 1/4)	38.100 (1 1/2)	28.58 (1.125)	—					45 300	114 000	4 500	—
31.750 (1 1/4)	38.100 (1 1/2)	31.75 (1.250)	—					49 400	128 000	4 500	IRB 1620
31.750 (1 1/4)	41.275 (1 5/8)	12.70 (.500)	3.4					13 700	17 600	12 000	IRB 168
31.750 (1 1/4)	41.275 (1 5/8)	19.05 (.750)	3.4					24 100	36 400	12 000	IRB 1612
31.750 (1 1/4)	41.275 (1 5/8)	25.40 (1.000)	3.4	31.750	31.734	41.289	41.264	33 200	55 000	12 000	IRB 1616
31.750 (1 1/4)	41.275 (1 5/8)	31.75 (1.250)	3.4					40 000	69 600	12 000	IRB 1620
33.338 (1 5/16)	41.275 (1 5/8)	12.70 (.500)	2.8					11 100	15 800	11 000	IRB 168-1
33.338 (1 5/16)	41.275 (1 5/8)	15.88 (.625)	2.8	33.338	33.322	41.289	41.264	15 400	23 900	11 000	IRB 1610-1
33.338 (1 5/16)	41.275 (1 5/8)	19.05 (.750)	2.8					19 300	32 100	11 000	IRB 1612-1

SHELL TYPE NEEDLE ROLLER BEARINGS

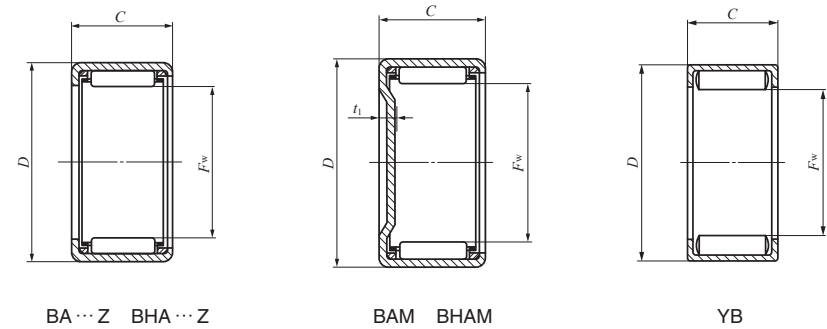
Inch Series



Shaft dia. 34.925 – 38.100mm

Shaft dia. mm (inch)	Identification number									
	Standard	Mass (Ref.) g	Closed end	Mass (Ref.) g	Standard	Mass (Ref.) g	Closed end	Mass (Ref.) g	Grease retained	Mass (Ref.) g
34.925 (1 3/8)	BA 228 Z	23.5	BAM 228	29	—	—	—	—	—	—
	BA 2212 Z	35.5	BAM 2212	41	—	—	—	—	—	—
	BA 2216 Z	47.5	BAM 2216	53	—	—	—	—	—	—
	BA 2220 Z	59	BAM 2220	64	—	—	—	—	—	—
	—	—	—	—	—	—	—	—	YB 228	30.5
	—	—	—	—	—	—	—	—	YB 2212	46
	—	—	—	—	—	—	—	—	YB 2220	77.5
	—	—	—	—	BHA 228 Z	37	BHAM 228	43	—	—
	—	—	—	—	BHA 2210 Z	44	BHAM 2210	50	—	—
	—	—	—	—	BHA 2212 Z	53	BHAM 2212	59	—	—
—	—	—	—	BHA 2216 Z	71	BHAM 2216	77	—	—	
—	—	—	—	BHA 2220 Z	87	BHAM 2220	98.5	—	—	
38.100 (1 1/2)	BA 248 Z	38.5	BAM 248	47.5	—	—	—	—	—	—
	BA 2410 Z	48.5	BAM 2410	57.5	—	—	—	—	—	—
	BA 2412 Z	58.5	BAM 2412	67.5	—	—	—	—	—	—
	BA 2414 Z	69	BAM 2414	78	—	—	—	—	—	—
	BA 2416 Z	79	BAM 2416	88	—	—	—	—	—	—
	BA 2420 Z	97.5	BAM 2420	106	—	—	—	—	—	—
	—	—	—	—	—	—	—	—	YB 246	38
	—	—	—	—	—	—	—	—	YB 248	51.5
	—	—	—	—	—	—	—	—	YB 2414	91
	—	—	—	—	—	—	—	—	YB 2416	105
—	—	—	—	—	—	—	—	YB 2420	131	

Note(1) Allowable rotational speed applies to oil lubrication. For grease lubrication, a maximum of 60% of this value is allowable.
 Remark Shell Type Grease Retained Full Complement Needle Roller Bearings are provided with prepacked grease. Standard type and closed end type bearings are not provided with prepacked grease, so perform proper lubrication when using these types of bearings.



Boundary dimensions mm(inch)				Standard mounting dimensions mm				Basic dynamic load rating C N	Basic static load rating C ₀ N	Allowable rotational speed ⁽¹⁾ min ⁻¹	Assembled inner ring
F _w	D	C	t ₁ Max.	Shaft dia. h6		Housing bore dia. J7					
				Max.	Min.	Max.	Min.				
34.925 (1 3/8)	41.275 (1 5/8)	12.70 (.500)	2.8					9 770	16 600	10 000	IRB 188
34.925 (1 3/8)	41.275 (1 5/8)	19.05 (.750)	2.8					16 900	33 500	10 000	IRB 1812
34.925 (1 3/8)	41.275 (1 5/8)	25.40(1.000)	2.8					23 100	50 200	10 000	IRB 1816
34.925 (1 3/8)	41.275 (1 5/8)	31.75(1.250)	2.8	34.925	34.909	41.289	41.264	28 900	67 100	10 000	IRB 1820
34.925 (1 3/8)	41.275 (1 5/8)	12.70 (.500)	—					23 000	49 500	4 500	IRB 188
34.925 (1 3/8)	41.275 (1 5/8)	19.05 (.750)	—					33 400	79 800	4 500	IRB 1812
34.925 (1 3/8)	41.275 (1 5/8)	31.75(1.250)	—					52 000	141 000	4 500	IRB 1820
34.925 (1 3/8)	44.450 (1 3/4)	12.70 (.500)	3.4					14 100	18 800	10 000	IRB 188
34.925 (1 3/8)	44.450 (1 3/4)	15.88 (.625)	3.4					19 700	28 800	10 000	—
34.925 (1 3/8)	44.450 (1 3/4)	19.05 (.750)	3.4	34.925	34.909	44.464	44.439	24 800	38 800	10 000	IRB 1812
34.925 (1 3/8)	44.450 (1 3/4)	25.40(1.000)	3.4					34 100	58 400	10 000	IRB 1816
34.925 (1 3/8)	44.450 (1 3/4)	31.75(1.250)	3.4					41 200	74 200	10 000	IRB 1820
38.100 (1 1/2)	47.625 (1 7/8)	12.70 (.500)	2.8					12 900	17 900	9 000	—
38.100 (1 1/2)	47.625 (1 7/8)	15.88 (.625)	2.8					17 800	27 100	9 000	IRB 2010
38.100 (1 1/2)	47.625 (1 7/8)	19.05 (.750)	2.8					22 500	36 600	9 000	—
38.100 (1 1/2)	47.625 (1 7/8)	22.22 (.875)	2.8	38.100	38.084	47.639	47.614	26 700	45 600	9 000	IRB 2014
38.100 (1 1/2)	47.625 (1 7/8)	25.40(1.000)	2.8					31 100	55 400	9 000	IRB 2016
38.100 (1 1/2)	47.625 (1 7/8)	31.75(1.250)	2.8					39 000	74 200	9 000	IRB 2020
38.100 (1 1/2)	47.625 (1 7/8)	9.52 (.375)	—					21 000	34 100	4 000	—
38.100 (1 1/2)	47.625 (1 7/8)	12.70 (.500)	—					28 700	50 900	4 000	—
38.100 (1 1/2)	47.625 (1 7/8)	22.22 (.875)	—	38.100	38.084	47.639	47.614	48 900	101 000	4 000	IRB 2014
38.100 (1 1/2)	47.625 (1 7/8)	25.40(1.000)	—					55 100	118 000	4 000	IRB 2016
38.100 (1 1/2)	47.625 (1 7/8)	31.75(1.250)	—					66 800	151 000	4 000	IRB 2020

SHELL TYPE NEEDLE ROLLER BEARINGS

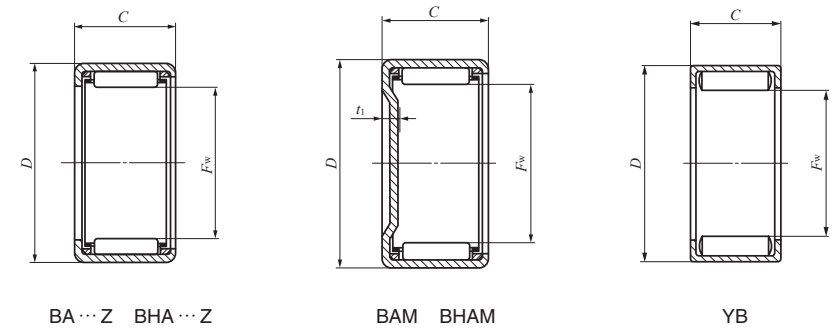
Inch Series



Shaft dia. 41.275 — 52.388mm

Shaft dia. mm (inch)	Identification number									
	Standard	Mass (Ref.) g	Closed end	Mass (Ref.) g	Standard	Mass (Ref.) g	Closed end	Mass (Ref.) g	Grease retained	Mass (Ref.) g
41.275 (1 5/8)	BA 268 Z	41	BAM 268	51.5	—	—	—	—	—	—
	BA 2610 Z	52	BAM 2610	62.5	—	—	—	—	—	—
	BA 2616 Z	85	BAM 2616	95.5	—	—	—	—	—	—
	BA 2620 Z	105	BAM 2620	115	—	—	—	—	—	—
	—	—	—	—	—	—	—	—	YB 2610	69
44.450 (1 3/4)	BA 2812 Z	67.5	BAM 2812	79.5	—	—	—	—	—	—
	BA 2816 Z	91	BAM 2816	103	—	—	—	—	—	—
	BA 2820 Z	112	BAM 2820	125	—	—	—	—	—	—
	BA 2824 Z	136	BAM 2824	148	—	—	—	—	—	—
	—	—	—	—	—	—	—	—	YB 2816	119
	—	—	—	—	BHA 2824 Z	195	BHAM 2824	210	—	—
47.625 (1 7/8)	BA 308 Z	47.5	BAM 308	61	—	—	—	—	—	—
	BA 3010 Z	60	BAM 3010	74	—	—	—	—	—	—
	BA 3012 Z	72.5	BAM 3012	86.5	—	—	—	—	—	—
	BA 3016 Z	97.5	BAM 3016	112	—	—	—	—	—	—
	—	—	—	—	—	—	—	—	YB 3012	95
50.800 (2)	BA 328 Z	50	BAM 328	66	—	—	—	—	—	—
	BA 3216 Z	104	BAM 3216	119	—	—	—	—	—	—
	BA 3220 Z	128	BAM 3220	144	—	—	—	—	—	—
	BA 3224 Z	155	BAM 3224	170	—	—	—	—	—	—
	BAW3228Z	180	BAMW3228	196	—	—	—	—	—	—
	—	—	—	—	—	—	—	—	YB 3216	130
52.388 (2 1/16)	—	—	—	—	BHA 3312 Z	104	BHAM 3312	122	—	—
	—	—	—	—	BHA 3316 Z	139	BHAM 3316	157	—	—
	—	—	—	—	BHA 3324 Z	205	BHAM 3324	225	—	—

Note(1) Allowable rotational speed applies to oil lubrication. For grease lubrication, a maximum of 60% of this value is allowable.
 Remarks1. "W" in the identification number indicates that rolling elements are arranged in double rows.
 2. Shell Type Grease Retained Full Complement Needle Roller Bearings are provided with prepacked grease. Standard type and closed end type bearings are not provided with prepacked grease, so perform proper lubrication when using these types of bearings.



Boundary dimensions mm(inch)				Standard mounting dimensions mm				Basic dynamic load rating C N	Basic static load rating C ₀ N	Allowable rotational speed ⁽¹⁾ min ⁻¹	Assembled inner ring
F _w	D	C	t ₁ Max.	Shaft dia. h6 Max. Min.		Housing bore dia. J7 Max. Min.					
41.275 (1 5/8)	50.800 (2)	12.70 (.500)	2.8	—	—	—	—	13 700	19 800	8 000	—
41.275 (1 5/8)	50.800 (2)	15.88 (.625)	2.8	—	—	—	—	18 900	30 000	8 000	IRB 2210
41.275 (1 5/8)	50.800 (2)	25.40(1.000)	2.8	41.275	41.259	50.818	50.788	33 000	61 400	8 000	—
41.275 (1 5/8)	50.800 (2)	31.75(1.250)	2.8	—	—	—	—	41 400	82 100	8 000	IRB 2220
41.275 (1 5/8)	50.800 (2)	15.88 (.625)	—	—	—	—	—	37 000	71 700	3 500	IRB 2210
44.450 (1 3/4)	53.975 (2 1/8)	19.05 (.750)	2.8	—	—	—	—	25 200	44 500	7 500	IRB 2412
44.450 (1 3/4)	53.975 (2 1/8)	25.40(1.000)	2.8	—	—	—	—	34 800	67 400	7 500	IRB 2416
44.450 (1 3/4)	53.975 (2 1/8)	31.75(1.250)	2.8	44.450	44.434	53.993	53.963	43 600	90 200	7 500	—
44.450 (1 3/4)	53.975 (2 1/8)	38.10(1.500)	2.8	—	—	—	—	52 000	113 000	7 500	IRB 2424
44.450 (1 3/4)	53.975 (2 1/8)	25.40(1.000)	—	—	—	—	—	59 500	136 000	3 500	IRB 2416
44.450 (1 3/4)	57.150 (2 1/4)	38.10(1.500)	3.4	44.450	44.434	57.168	57.138	72 200	135 000	7 500	IRB 2424
47.625 (1 7/8)	57.150 (2 1/4)	12.70 (.500)	2.8	—	—	—	—	14 700	22 800	7 000	IRB 248-1
47.625 (1 7/8)	57.150 (2 1/4)	15.88 (.625)	2.8	—	—	—	—	20 300	34 500	7 000	IRB 2410-1
47.625 (1 7/8)	57.150 (2 1/4)	19.05 (.750)	2.8	47.625	47.609	57.168	57.138	25 700	46 700	7 000	—
47.625 (1 7/8)	57.150 (2 1/4)	25.40(1.000)	2.8	—	—	—	—	35 400	70 600	7 000	—
47.625 (1 7/8)	57.150 (2 1/4)	19.05 (.750)	—	—	—	—	—	47 800	105 000	3 000	—
50.800 (2)	60.325 (2 3/8)	12.70 (.500)	2.8	—	—	—	—	15 400	24 700	6 000	—
50.800 (2)	60.325 (2 3/8)	25.40(1.000)	2.8	—	—	—	—	37 100	76 500	6 000	IRB 2616
50.800 (2)	60.325 (2 3/8)	31.75(1.250)	2.8	—	—	—	—	46 600	102 000	6 000	IRB 2720
50.800 (2)	60.325 (2 3/8)	38.10(1.500)	2.8	50.800	50.781	60.343	60.313	55 500	128 000	6 000	—
50.800 (2)	60.325 (2 3/8)	44.45(1.750)	2.8	—	—	—	—	57 900	136 000	6 000	IRB 2628
50.800 (2)	60.325 (2 3/8)	25.40(1.000)	—	—	—	—	—	64 100	156 000	2 500	IRB 2616
52.388 (2 1/16)	64.294 (2 17/32)	19.05 (.750)	3.4	—	—	—	—	36 400	62 100	6 000	—
52.388 (2 1/16)	64.294 (2 17/32)	25.40(1.000)	3.4	52.388	52.369	64.312	64.282	50 600	94 700	6 000	—
52.388 (2 1/16)	64.294 (2 17/32)	38.10(1.500)	3.4	—	—	—	—	73 900	154 000	6 000	—

SHELL TYPE NEEDLE ROLLER BEARINGS

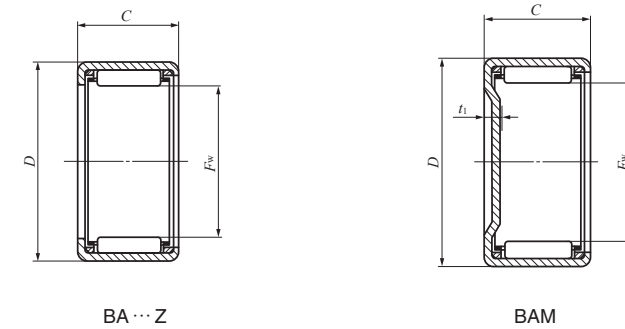
Inch Series



Shaft dia. 53.975 – 69.850mm

Shaft dia. mm (inch)	Identification number									
	Standard	Mass (Ref.) g	Closed end	Mass (Ref.) g	Standard	Mass (Ref.) g	Closed end	Mass (Ref.) g	Grease retained	Mass (Ref.) g
53.975 (2 1/8)	BA 348 Z	53	BAM 348	70.5	—	—	—	—	—	—
	BA 3416 Z	109	BAM 3416	127	—	—	—	—	—	—
	BA 3424 Z	162	BAM 3424	180	—	—	—	—	—	—
57.150 (2 1/4)	BA 3612 Z	85.5	BAM 3612	105	—	—	—	—	—	—
	BA 3616 Z	115	BAM 3616	135	—	—	—	—	—	—
	BA 3620 Z	143	BAM 3620	163	—	—	—	—	—	—
	BA 3624 Z	172	BAM 3624	192	—	—	—	—	—	—
66.675 (2 5/8)	BA 4216 Z	133	BAM 4216	161	—	—	—	—	—	—
69.850 (2 3/4)	BA 4410 Z	85.5	BAM 4410	115	—	—	—	—	—	—
	BA 4412 Z	103	BAM 4412	133	—	—	—	—	—	—
	BA 4416 Z	139	BAM 4416	169	—	—	—	—	—	—
	BA 4420 Z	173	BAM 4420	205	—	—	—	—	—	—

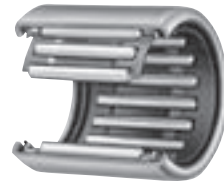
Note(1) Allowable rotational speed applies to oil lubrication. For grease lubrication, a maximum of 60% of this value is allowable.
 Remark Shell Type Grease Retained Full Complement Needle Roller Bearings are provided with prepacked grease. Standard type and closed end type bearings are not provided with prepacked grease, so perform proper lubrication when using these types of bearings.



Boundary dimensions mm(inch)				Standard mounting dimensions mm				Basic dynamic load rating C	Basic static load rating C ₀	Allowable rotational speed ⁽¹⁾ min ⁻¹	Assembled inner ring
F _w	D	C	t ₁ Max.	Shaft dia. h6		Housing bore dia. J7					
				Max.	Min.	Max.	Min.	N	N		
53.975(2 1/8)	63.500(2 1/2)	12.70(.500)	2.8					16 100	26 600	5 500	—
53.975(2 1/8)	63.500(2 1/2)	25.40(1.000)	2.8	53.975	53.956	63.518	63.488	38 700	82 500	5 500	IRB 3016
53.975(2 1/8)	63.500(2 1/2)	38.10(1.500)	2.8					57 900	138 000	5 500	IRB 3024
57.150(2 1/4)	66.675(2 5/8)	19.05(.750)	2.8					28 500	56 700	5 000	—
57.150(2 1/4)	66.675(2 5/8)	25.40(1.000)	2.8	57.150	57.131	66.693	66.663	39 300	85 700	5 000	—
57.150(2 1/4)	66.675(2 5/8)	31.75(1.250)	2.8					49 400	115 000	5 000	—
57.150(2 1/4)	66.675(2 5/8)	38.10(1.500)	2.8					58 800	144 000	5 000	—
66.675(2 5/8)	76.200(3)	25.40(1.000)	2.8	66.675	66.656	76.218	76.188	42 000	97 900	4 000	IRB 3616
69.850(2 3/4)	79.375(3 1/8)	15.88(.625)	2.8					25 000	50 800	3 500	—
69.850(2 3/4)	79.375(3 1/8)	19.05(.750)	2.8	69.850	69.831	79.393	79.363	31 500	68 700	3 500	—
69.850(2 3/4)	79.375(3 1/8)	25.40(1.000)	2.8					43 500	104 000	3 500	IRB 4016
69.850(2 3/4)	79.375(3 1/8)	31.75(1.250)	2.8					54 600	139 000	3 500	IRB 4020

SHELL TYPE NEEDLE ROLLER BEARINGS

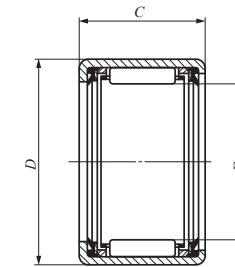
With seals



Shaft dia. 12 – 50mm

Shaft dia. mm	Identification number	Mass (Ref.) g	Boundary dimensions mm			Standard mounting dimensions mm			
			F_w	D	C	Shaft dia. h6		Housing bore dia. N7	
						Max.	Min.	Max.	Min.
12	TLA 1216 UU	11.7	12	18	16	12.000	11.989	17.995	17.977
14	TLA 1416 UU	13.3	14	20	16	14.000	13.989	19.993	19.972
15	TLA 1516 UU	14	15	21	16	15.000	14.989	20.993	20.972
16	TLA 1616 UU	14.8	16	22	16	16.000	15.989	21.993	21.972
18	TLA 1816 UU	16.3	18	24	16	18.000	17.989	23.993	23.972
20	TLA 2016 UU TLA 2020 UU	17.8 22.5	20 20	26 26	16 20	20.000	19.987	25.993	25.972
22	TLA 2216 UU TLA 2220 UU	19.4 25	22 22	28 28	16 20	22.000	21.987	27.993	27.972
25	TLA 2516 UU TLA 2520 UU	26 33	25 25	32 32	16 20	25.000	24.987	31.992	31.967
28	TLA 2820 UU	36.5	28	35	20	28.000	27.987	34.992	34.967
30	TLA 3016 UU TLA 3020 UU	30.5 39	30 30	37 37	16 20	30.000	29.987	36.992	36.967
35	TLA 3516 UU TLA 3520 UU	35 45	35 35	42 42	16 20	35.000	34.984	41.992	41.967
40	TLA 4016 UU TLA 4020 UU	39.5 50.5	40 40	47 47	16 20	40.000	39.984	46.992	46.967
45	TLA 4520 UU	56	45	52	20	45.000	44.984	51.991	51.961
50	TLA 5026 UU	89	50	58	26	50.000	49.984	57.991	57.961

Note(1) Allowable rotational speed applies to grease lubrication.
Remark The type with seals is provided with prepacked grease.



TLA ... UU

Basic dynamic load rating C N	Basic static load rating C_0 N	Allowable rotational speed ⁽¹⁾ min ⁻¹
6 420	7 490	14 000
7 080	8 840	12 000
7 380	9 520	11 000
7 670	10 200	11 000
8 230	11 500	9 000
8 740 11 100	12 900 17 500	9 000 9 000
9 230 11 700	14 300 19 300	8 000 8 000
9 440 12 800	13 900 20 500	7 000 7 000
13 800	23 500	6 000
10 400 14 100	16 600 24 500	5 500 5 500
11 600 15 700	20 000 29 600	5 000 5 000
12 400 16 700	22 800 33 700	4 500 4 500
17 800	37 800	4 000
28 800	64 100	3 500

NEEDLE ROLLER CAGES FOR GENERAL USAGE

- High carbon steel cage type
- Synthetic resin cage type



Structure and Features

IKO Needle Roller Cages for General Usage are bearings which display excellent rotational performance. Needle rollers with extremely small dimensional variations in diameter are incorporated and retained in their specially shaped cages with high rigidity and accuracy, which precisely guide the needle rollers.

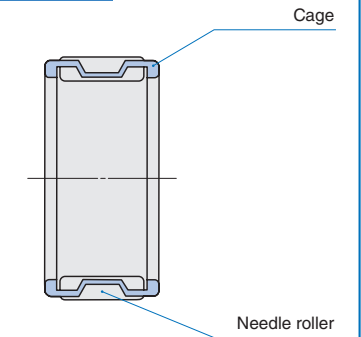
When combined with shafts and housing bores that are heat treated and accurately ground as raceway surfaces, Needle Roller Cages for General Usage are particularly useful in small spaces.

In addition, since they are lightweight and have high rigidity as well as a large lubricant holding capacity, they can withstand severe operating conditions such as high speed rotation and shock loads, and they are used in a wide range of applications.

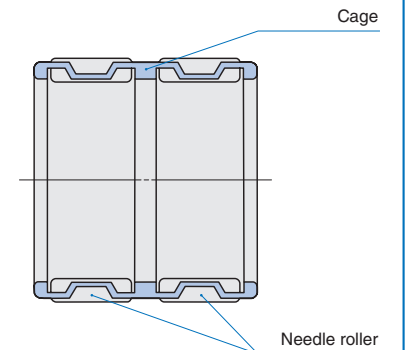
Structures of Needle Roller Cages for General Usage

High carbon steel cage type

KT

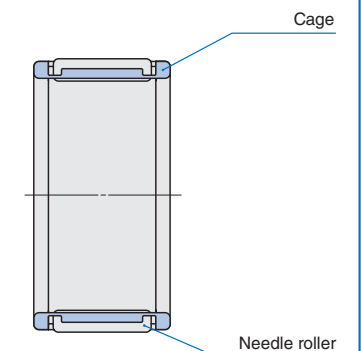


KTW



Synthetic resin cage type

KT···N



Types

Needle Roller Cages for General Usage are available in the types shown in Table 1.

For applications such as crank shafts where these bearings are difficult to install, it is also possible to make split type bearings.

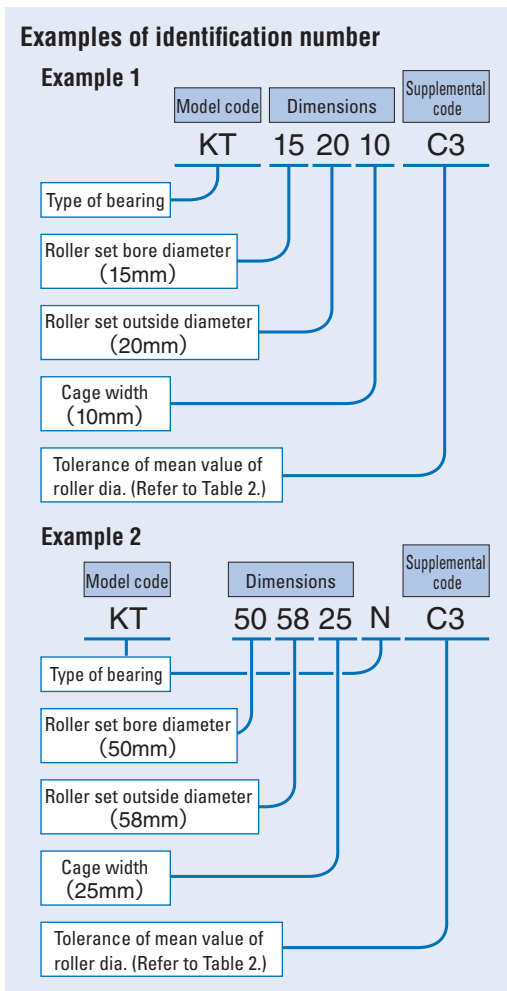
If such bearings are required, please contact IKO. For Needle Roller Cages for Engine Connecting Rods (KT...EG and KTV...EG), see page C17.

Table 1 Model of bearing

Item	Model of bearing	
	Single row needle roller	Double row needle roller
High carbon steel cage type	KT	KTW
Synthetic resin cage type	KT...N	-

Identification Number

The identification number of Needle Roller Cages for General Usage consists of a model code, dimensions and any supplemental codes. The arrangement examples are shown below.



Accuracy

The diameter tolerances of needle rollers of Needle Roller Cages for General Usage are classified by classification symbols shown in Table 2. If a classification symbol is not indicated in an identification number, the classification symbol "C3" is applied.

When two or more bearings are used in tandem arrangement on the same shaft, it is necessary to select bearings of the same classification symbol to obtain an even load distribution.

The tolerance of the cage width B_c is $-0.20 \sim -0.55$ mm.

Table 2 Diameter tolerances of needle rollers unit: μm

Classification symbol	Tolerance of mean value of needle roller diameter
C 3	0 ~ - 3
B 2	0 ~ - 2
B 4	- 2 ~ - 4
B 6	- 4 ~ - 6
B 8	- 6 ~ - 8
B10	- 8 ~ - 10

Fit

Radial clearances of Needle Roller Cages for General Usage are determined by the dimensional accuracy of the raceways and needle rollers. Table 3 shows the recommended fits for the operating conditions.

Table 3 Recommended fits of shaft to the housing bore diameter G6

Operating conditions	Shaft	Tolerance class of shaft	
		$F_w \leq 68mm$	$F_w > 68mm$
When high operating accuracy is required. When shock loads and oscillating motions are applied.		j5	h5
For general use		h5	g5
When the temperature is high, or mounting errors are large.		g6	f6

Remark When setting the required radial clearance according to the operating conditions, the clearance can easily be obtained by selecting and matching the tolerances of needle rollers, shaft and housing bore. When variation of the clearance does not create any problems, h6 and G7 are used for shaft and housing bore, respectively.

Specifications of shaft and housing

For the raceways, a surface hardness of 58 ~ 64HRC and a surface roughness $0.2 \mu m R_a$ or less are desirable. However, when the operating conditions are not severe, a surface roughness $0.8 \mu m R_a$ or less can be used.

When the surface hardness is low, it is necessary to correct the load rating by the hardness factor specified on page A20.

Operating temperature range

The operating temperature range for high carbon steel cage types is -20 to $120^\circ C$. The maximum allowable temperature for synthetic resin cage types is $+110^\circ C$, and $+100^\circ C$ when they are continuously operated.

Mounting

The dimensions related to mounting of Needle Roller Cages for General Usage are shown in Figs. 1 and 2. When mounting Needle Roller Cages for General Usage, they are axially positioned by using, for example, Cir-clips for shaft and housing bore (WR and AR on page L17) as shown in Figs. 3, 4 and 5.

For high rotational speed applications, a heat treated and ground spacer is positioned between the cage and the cir-clip as shown in Fig. 5 so that the cage does not make direct contact with the cir-clip. In this case, the cir-clip is normally mounted on the non-rotating side.

Fig. 3 shows a mounting example in the case of outer ring rotation, and Figs. 4 and 5 show examples in the case of inner ring rotation.

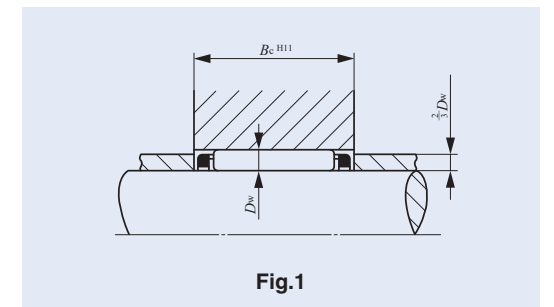


Fig.1

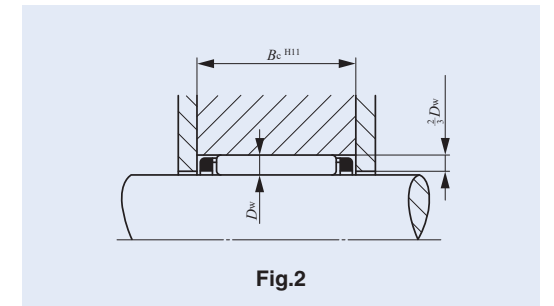


Fig.2

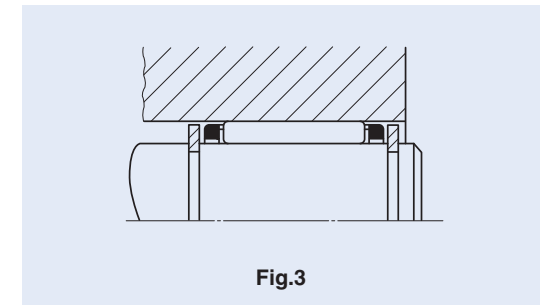


Fig.3

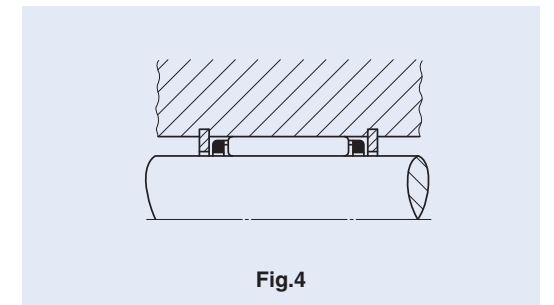


Fig.4

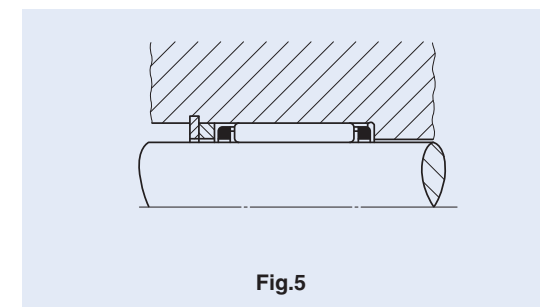


Fig.5

NEEDLE ROLLER CAGES FOR GENERAL USAGE



High carbon steel cage type

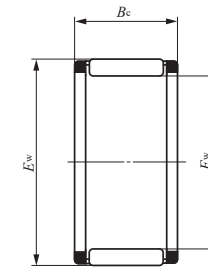


Synthetic resin cage type

Shaft dia. 3 – 14mm

Shaft dia. mm	Identification number	Mass (Ref.) g	Boundary dimensions mm			Basic dynamic load rating <i>C</i> N	Basic static load rating <i>C</i> ₀ N	Allowable rotational speed ⁽¹⁾ min ⁻¹
			<i>F</i> _w	<i>E</i> _w	<i>B</i> _c			
3	KT 367N	0.39	3	6	7	1 480	990	140 000
4	KT 477N	0.47	4	7	7	1 800	1 300	100 000
5	KT 587N	0.53	5	8	7	2 070	1 600	85 000
	KT 588N	0.66	5	8	8	2 420	1 950	85 000
6	KT 697N	0.63	6	9	7	2 310	1 900	75 000
	KT 698N	0.75	6	9	8	2 700	2 320	75 000
	KT 6910	1.45	6	9	10	3 010	2 660	75 000
	KT 61013	2.7	6	10	13	4 410	3 720	75 000
7	KT 7108N	0.86	7	10	8	2 960	2 690	65 000
	KT 71010	1.69	7	10	10	3 340	3 130	65 000
8	KT 8118N	0.96	8	11	8	3 190	3 060	60 000
	KT 81110	1.9	8	11	10	3 630	3 600	60 000
	KT 81110N	1.2	8	11	10	3 630	3 600	60 000
	KT 81113	2.5	8	12	13	4 500	4 750	60 000
	KT 8128	2.1	8	12	8	3 630	3 040	60 000
	KT 81211	3	8	12	11	4 630	4 170	60 000
9	KT 91210	2.1	9	12	10	3 900	4 070	55 000
	KT 91213	2.8	9	12	13	4 840	5 370	55 000
10	KT 10138	1.9	10	13	8	3 370	3 470	50 000
	KT 101310	2.3	10	13	10	4 160	4 550	50 000
	KT 101313	3	10	13	13	5 160	6 000	50 000
	KT 101410	3.2	10	14	10	4 900	4 680	50 000
	KT 101412	3.8	10	14	12	5 940	6 000	50 000
11	KT 101413	4.2	10	14	13	6 100	6 200	50 000
	KT 101415	4.8	10	14	15	7 080	7 520	50 000
11	KT 111410	2.5	11	14	10	4 400	5 020	45 000

Note⁽¹⁾ Allowable rotational speed applies to oil lubrication. For grease lubrication, a maximum of 50% of this value is allowable.
 Remark For synthetic resin cage types, "N" is added at the end of the identification number. For sizes not listed in the dimension tables, please contact IKO.



KT (...N)

Shaft dia. mm	Identification number	Mass (Ref.) g	Boundary dimensions mm			Basic dynamic load rating <i>C</i> N	Basic static load rating <i>C</i> ₀ N	Allowable rotational speed ⁽¹⁾ min ⁻¹
			<i>F</i> _w	<i>E</i> _w	<i>B</i> _c			
12	KT 12158	2.2	12	15	8	3 750	4 200	40 000
	KT 121510	2.7	12	15	10	4 620	5 490	40 000
	KT 121512	3.2	12	15	12	5 590	7 020	40 000
	KT 121513	3.6	12	15	13	5 730	7 250	40 000
	KT 121514	3.8	12	15	14	6 200	8 010	40 000
	KT 121610	4	12	16	10	5 650	5 890	40 000
	KT 121613	5.2	12	16	13	7 020	7 800	40 000
	KT 121618	7	12	16	18	9 790	11 900	40 000
	KT 121710	5.1	12	17	10	6 170	5 740	40 000
	KT 121812	7.8	12	18	12	9 030	8 460	40 000
KT 121820	13.2	12	18	20	13 700	14 400	40 000	
13	KT 131710	4.3	13	17	10	5 990	6 500	40 000
	KT 131815	8.2	13	18	15	9 660	10 400	40 000
	KT 131816	8.7	13	18	16	10 300	11 400	40 000
14	KT 14188	3.7	14	18	8	5 110	5 410	35 000
	KT 141810	4.6	14	18	10	6 320	7 110	35 000
	KT 141811	5.2	14	18	11	6 520	7 410	35 000
	KT 141813	6	14	18	13	7 860	9 410	35 000
	KT 141816	7.3	14	18	16	9 750	12 400	35 000
	KT 141910	5.9	14	19	10	7 130	7 180	35 000
	KT 141916	9.4	14	19	16	11 100	12 600	35 000
	KT 141918	10.5	14	19	18	12 400	14 700	35 000
KT 142012	8.7	14	20	12	9 790	9 680	35 000	
KT 142017	12.4	14	20	17	13 300	14 400	35 000	

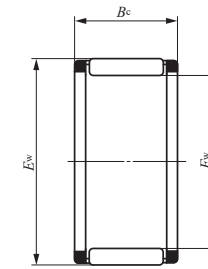


High carbon steel cage type

Shaft dia. 15 – 18mm

Shaft dia. mm	Identification number	Mass (Ref.) g	Boundary dimensions mm			Basic dynamic load rating <i>C</i> N	Basic static load rating <i>C</i> ₀ N	Allowable rotational speed ⁽¹⁾ min ⁻¹
			<i>F</i> _w	<i>E</i> _w	<i>B</i> _c			
15	KT 15199	4.4	15	19	9	6 120	6 950	35 000
	KT 151910	4.9	15	19	10	6 630	7 720	35 000
	KT 151911	5.5	15	19	11	6 850	8 040	35 000
	KT 151913	6.4	15	19	13	8 250	10 200	35 000
	KT 151917	8.2	15	19	17	10 900	14 600	35 000
	KT 151918	8.7	15	19	18	11 500	15 600	35 000
	KT 152010	6.3	15	20	10	7 580	7 920	35 000
	KT 152115	11.9	15	21	15	12 600	13 500	35 000
16	KT 162010	5.2	16	20	10	6 930	8 330	30 000
	KT 162013	6.8	16	20	13	8 620	11 000	30 000
	KT 162016	8.3	16	20	16	10 700	14 600	30 000
	KT 162017	8.7	16	20	17	11 400	15 700	30 000
	KT 162118	12	16	21	18	14 000	17 700	30 000
	KT 162120	13.6	16	21	20	14 700	18 900	30 000
	KT 162125	16.6	16	21	25	18 300	25 100	30 000
	KT 162212	9.7	16	22	12	10 500	10 900	30 000
	KT 162214	11.5	16	22	14	11 600	12 500	30 000
	KT 162217	13.8	16	22	17	14 200	16 100	30 000
	KT 162220	16.5	16	22	20	15 900	18 600	30 000
	KT 162420	23.5	16	24	20	18 500	19 000	30 000
17	KT 172110	5.5	17	21	10	7 220	8 950	30 000
	KT 172113	7.2	17	21	13	8 980	11 800	30 000
	KT 172115	8.2	17	21	15	10 400	14 400	30 000
	KT 172117	9.3	17	21	17	11 800	16 900	30 000
	KT 172220	14	17	22	20	15 500	20 500	30 000
	KT 172311	9.6	17	23	11	10 100	10 500	30 000
	KT 172315	13.1	17	23	15	13 300	15 100	30 000
KT 172418	18.6	17	24	18	16 500	18 000	30 000	

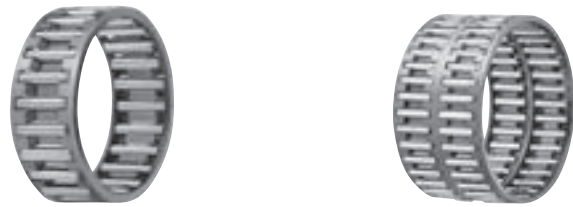
Note⁽¹⁾ Allowable rotational speed applies to oil lubrication. For grease lubrication, a maximum of 50% of this value is allowable.



KT

Shaft dia. mm	Identification number	Mass (Ref.) g	Boundary dimensions mm			Basic dynamic load rating <i>C</i> N	Basic static load rating <i>C</i> ₀ N	Allowable rotational speed ⁽¹⁾ min ⁻¹
			<i>F</i> _w	<i>E</i> _w	<i>B</i> _c			
18	KT 18228	4.7	18	22	8	6 060	7 270	30 000
	KT 182210	5.8	18	22	10	7 500	9 560	30 000
	KT 182213	7.6	18	22	13	9 330	12 700	30 000
	KT 182216	9.2	18	22	16	11 600	16 700	30 000
	KT 182412	11	18	24	12	11 800	13 100	30 000
	KT 182416	14.8	18	24	16	15 100	17 900	30 000
	KT 182417	15.7	18	24	17	16 000	19 400	30 000
	KT 182420	18.7	18	24	20	17 900	22 400	30 000
	KT 182517	18.8	18	25	17	16 700	18 600	30 000
	KT 182519	21	18	25	19	18 700	21 400	30 000
	KT 182522	24.5	18	25	22	20 600	24 200	30 000
	KT 182614	18.1	18	26	14	14 600	14 400	30 000
	KT 182620	26	18	26	20	20 000	21 600	30 000

NEEDLE ROLLER CAGES FOR GENERAL USAGE

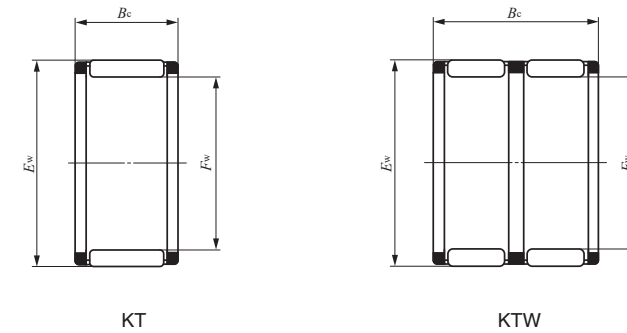


High carbon steel cage type

Shaft dia. 20 – 24mm

Shaft dia. mm	Identification number	Mass (Ref.) g	Boundary dimensions mm			Basic dynamic load rating <i>C</i> N	Basic static load rating <i>C</i> ₀ N	Allowable rotational speed ⁽¹⁾ min ⁻¹
			<i>F</i> _w	<i>E</i> _w	<i>B</i> _c			
20	KT 202410	6.3	20	24	10	7 710	10 200	25 000
	KT 202413	8.3	20	24	13	9 590	13 500	25 000
	KT 202417	10.6	20	24	17	12 600	19 300	25 000
	KTW 202422	14.6	20	24	22	13 700	21 300	25 000
	KT 202525	19.7	20	25	25	19 900	29 800	25 000
	KTW 202531.6	26.5	20	25	31.6	21 700	33 200	25 000
	KTW 202540	32.5	20	25	40	27 500	44 900	25 000
	KT 202611	11.1	20	26	11	11 200	12 500	25 000
	KT 202612	12	20	26	12	12 400	14 300	25 000
	KT 202614	14.2	20	26	14	13 700	16 400	25 000
	KT 202617	17	20	26	17	16 800	21 200	25 000
	KT 202620	20.5	20	26	20	18 700	24 400	25 000
	KT 202624	24	20	26	24	22 500	30 900	25 000
	KT 202627	26.5	20	26	27	26 000	37 300	25 000
	KT 202814	20	20	28	14	15 700	16 100	25 000
	KT 202820	29	20	28	20	21 500	24 200	25 000
KT 203225	49.5	20	32	25	30 800	30 500	25 000	
21	KT 212610	8.5	21	26	10	9 090	11 000	25 000
	KT 212611	9.6	21	26	11	9 390	11 500	25 000

Note⁽¹⁾ Allowable rotational speed applies to oil lubrication. For grease lubrication, a maximum of 50% of this value is allowable.



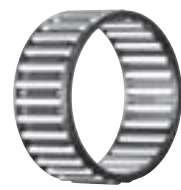
Shaft dia. mm	Identification number	Mass (Ref.) g	Boundary dimensions mm			Basic dynamic load rating <i>C</i> N	Basic static load rating <i>C</i> ₀ N	Allowable rotational speed ⁽¹⁾ min ⁻¹
			<i>F</i> _w	<i>E</i> _w	<i>B</i> _c			
22	KT 222610	6.9	22	26	10	8 220	11 500	25 000
	KT 222613	9.1	22	26	13	10 200	15 200	25 000
	KT 222617	11.6	22	26	17	13 500	21 600	25 000
	KTW 222625	17.7	22	26	25	17 100	29 400	25 000
	KT 222720	17.9	22	27	20	17 400	25 700	25 000
	KT 222726	22.5	22	27	26	22 500	35 800	25 000
	KT 222817	18.4	22	28	17	17 500	23 000	25 000
	KT 222912	16.1	22	29	12	12 900	14 000	25 000
	KT 222916	21	22	29	16	17 600	20 900	25 000
	KT 222917	22.5	22	29	17	18 700	22 600	25 000
	KT 222918	23.5	22	29	18	19 800	24 400	25 000
	KT 222920	26.5	22	29	20	20 900	26 100	25 000
	KT 223015	23.5	22	30	15	17 900	19 700	25 000
	KT 223230	52.5	22	32	30	36 400	42 700	25 000
KT 223232	56	22	32	32	38 800	46 300	25 000	
23	KT 232824	22	23	28	24	21 600	34 500	20 000
	KT 232913	15.1	23	29	13	13 800	17 200	20 000
	KT 233015	21	23	30	15	17 300	20 800	20 000
	KT 233016	22	23	30	16	18 600	22 600	20 000
24	KT 242813	9.9	24	28	13	10 800	16 800	20 000
	KT 242816	12	24	28	16	13 400	22 200	20 000
	KTW 242834	27	24	28	34	21 600	40 700	20 000
	KT 242913	12.8	24	29	13	12 700	17 600	20 000
	KT 243020	23.5	24	30	20	20 300	28 500	20 000



NEEDLE ROLLER CAGES FOR GENERAL USAGE



High carbon steel cage type

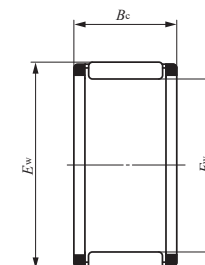


Synthetic resin cage type

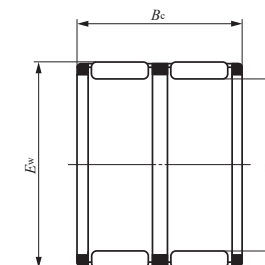
Shaft dia. 25 – 32mm

Shaft dia. mm	Identification number	Mass (Ref.) g	Boundary dimensions mm			Basic dynamic load rating <i>C</i> N	Basic static load rating <i>C</i> ₀ N	Allowable rotational speed ⁽¹⁾ min ⁻¹
			<i>F</i> _w	<i>E</i> _w	<i>B</i> _c			
25	KT 252910	7.9	25	29	10	8 940	13 300	20 000
	KT 252913	10.3	25	29	13	11 100	17 600	20 000
	KT 253013	13.3	25	30	13	13 100	18 600	20 000
	KT 253016	16.2	25	30	16	16 300	24 600	20 000
	KT 253017	17.1	25	30	17	17 300	26 600	20 000
	KT 253020	20	25	30	20	18 600	29 100	20 000
	KT 253113	16.2	25	31	13	14 300	18 400	20 000
	KT 253116	19.6	25	31	16	17 800	24 400	20 000
	KT 253117	20.5	25	31	17	19 000	26 500	20 000
	KT 253120	25	25	31	20	21 200	30 500	20 000
	KT 253216	23.5	25	32	16	19 400	24 500	20 000
	KT 253224	35	25	32	24	27 700	38 700	20 000
	KT 253515	33	25	35	15	22 600	23 800	20 000
	KT 253525	48	25	35	25	32 500	37 900	20 000
	KT 253530	58	25	35	30	39 100	48 000	20 000
26	KT 263013	10.7	26	30	13	11 400	18 400	19 000
	KT 263832	79.5	26	38	32	47 200	55 300	19 000
28	KT 283313	14.8	28	33	13	13 800	20 700	18 000
	KT 283317	18.9	28	33	17	18 300	29 500	18 000
	KT 283327	29	28	33	27	26 300	47 300	18 000
	KT 283417	23	28	34	17	20 300	29 900	18 000
	KT 283516	26	28	35	16	20 100	26 500	18 000
	KT 283528	44.5	28	35	28	33 200	50 600	18 000
	KT 283620	38.5	28	36	20	26 500	34 700	18 000
	KT 284138	110	28	41	38	58 700	71 100	18 000
29	KT 293825N	40.7	29	38	25	35 800	47 800	17 500

Note⁽¹⁾ Allowable rotational speed applies to oil lubrication. For grease lubrication, a maximum of 50% of this value is allowable.
 Remark For synthetic resin cage types, "N" is added at the end of the identification number. For sizes not listed in the dimension tables, please contact IKO.



KT (... N)



KTW

Shaft dia. mm	Identification number	Mass (Ref.) g	Boundary dimensions mm			Basic dynamic load rating <i>C</i> N	Basic static load rating <i>C</i> ₀ N	Allowable rotational speed ⁽¹⁾ min ⁻¹
			<i>F</i> _w	<i>E</i> _w	<i>B</i> _c			
30	KT 303513	15.6	30	35	13	14 100	21 700	17 000
	KT 303516	18.9	30	35	16	17 500	28 700	17 000
	KT 303517	20	30	35	17	18 700	31 100	17 000
	KT 303524	28.5	30	35	24	24 900	45 100	17 000
	KT 303527	31.5	30	35	27	27 900	52 100	17 000
	KT 303613	19.1	30	36	13	15 800	22 100	17 000
	KT 303620	29.5	30	36	20	23 300	36 500	17 000
	KT 303630	41.5	30	36	30	33 200	57 500	17 000
	KT 303715	26	30	37	15	19 500	26 000	17 000
	KT 303716	27.5	30	37	16	20 800	28 400	17 000
	KT 303720	35	30	37	20	24 700	35 400	17 000
	KT 303723	39.5	30	37	23	28 500	42 500	17 000
	KT 303818	36.5	30	38	18	26 200	34 800	17 000
	KT 303824	48.5	30	38	24	33 200	47 200	17 000
	KT 304232	93	30	42	32	54 000	68 100	17 000
	KTW 304237	117	30	42	37	55 900	71 300	17 000
	32	KT 323713	16.7	32	37	13	14 900	23 700
KT 323717		21.5	32	37	17	19 600	33 900	16 000
KT 323723		28.5	32	37	23	24 400	44 800	16 000
KT 323813		20.5	32	38	13	16 800	24 400	16 000
KT 323820		31.5	32	38	20	24 800	40 300	16 000
KT 323916		29	32	39	16	21 600	30 200	16 000
KT 323920		37	32	39	20	25 600	37 700	16 000
KT 324519		63.5	32	45	19	33 700	35 900	16 000
KT 324525		84.5	32	45	25	45 600	53 000	16 000
KT 324532		109	32	45	32	58 500	73 000	16 000
KT 324550		162	32	45	50	81 500	111 000	16 000



NEEDLE ROLLER CAGES FOR GENERAL USAGE



High carbon steel cage type

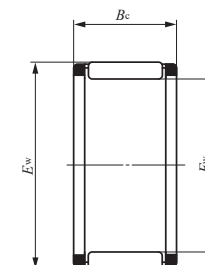


Synthetic resin cage type

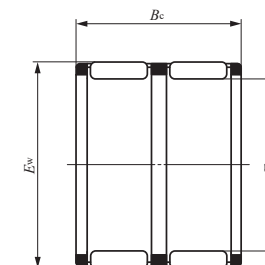
Shaft dia. 35 – 52mm

Shaft dia. mm	Identification number	Mass (Ref.) g	Boundary dimensions mm			Basic dynamic load rating C N	Basic static load rating C ₀ N	Allowable rotational speed ⁽¹⁾ min ⁻¹
			F _w	E _w	B _c			
35	KT 354013	18.1	35	40	13	15 500	25 800	14 000
	KT 354017	23	35	40	17	20 500	36 900	14 000
	KT 354026	34.5	35	40	26	28 700	56 800	14 000
	KT 354113	22.5	35	41	13	17 700	26 800	14 000
	KT 354216	32	35	42	16	23 100	33 900	14 000
	KT 354218	35.5	35	42	18	26 000	39 500	14 000
	KT 354220	40.5	35	42	20	27 400	42 300	14 000
	KT 354230	59	35	42	30	40 600	70 300	14 000
	KT 354525	68.5	35	45	25	42 100	57 900	14 000
36	KT 364216	27.5	36	42	16	21 900	35 700	14 000
38	KT 384417	30.5	38	44	17	23 800	40 400	13 000
	KT 384620	50	38	46	20	30 500	45 400	13 000
	KT 384632	80	38	46	32	45 400	75 700	13 000
40	KT 404513	20.5	40	45	13	16 800	29 800	12 000
	KT 404517	26.5	40	45	17	22 200	42 700	12 000
	KT 404527	41	40	45	27	32 400	69 200	12 000
	KT 404817	44	40	48	17	28 100	41 600	12 000
	KT 404820	52.5	40	48	20	31 400	48 000	12 000
	KT 404825	64.5	40	48	25	39 300	64 000	12 000
	KT 404834	87.5	40	48	34	51 100	89 600	12 000
	KT 405015	48.5	40	50	15	28 200	35 900	12 000
	KT 405017	56.5	40	50	17	30 200	39 200	12 000
	KT 405020	61	40	50	20	35 700	48 600	12 000
	KTW 405238	158	40	52	38	65 000	93 000	12 000
	KT 405432	144	40	54	32	66 800	87 200	12 000
	KT 405450	215	40	54	50	93 600	134 000	12 000
	KT 405463	270	40	54	63	115 000	175 000	12 000

Note⁽¹⁾ Allowable rotational speed applies to oil lubrication. For grease lubrication, a maximum of 50% of this value is allowable.
 Remark For synthetic resin cage types, "N" is added at the end of the identification number. For sizes not listed in the dimension tables, please contact IKO.



KT (... N)



KTW

Shaft dia. mm	Identification number	Mass (Ref.) g	Boundary dimensions mm			Basic dynamic load rating C N	Basic static load rating C ₀ N	Allowable rotational speed ⁽¹⁾ min ⁻¹
			F _w	E _w	B _c			
41	KT 414835	78.5	41	48	35	47 800	90 800	12 000
42	KT 424717	27.5	42	47	17	22 500	44 200	12 000
	KT 424815	30	42	48	15	22 400	38 600	12 000
	KT 424816	32	42	48	16	24 000	42 100	12 000
	KT 425020	55	42	50	20	32 400	50 600	12 000
	KT 425030	80.5	42	50	30	48 200	84 400	12 000
	45	KT 455017	29.5	45	50	17	23 300	47 100
KT 455027		46	45	50	27	34 800	79 000	11 000
KT 455320		58	45	53	20	33 200	53 300	11 000
KT 455325		71.5	45	53	25	41 500	71 100	11 000
KT 455330		86	45	53	30	47 800	85 300	11 000
KT 455335		101	45	53	35	53 900	99 500	11 000
48	KT 485320	37	48	53	20	26 800	57 600	10 000
	KT 485420	46	48	54	20	30 600	60 400	10 000
50	KT 505520	38.5	50	55	20	27 100	59 300	10 000
	KT 505527	50.5	50	55	27	35 600	84 100	10 000
	KT 505820	65	50	58	20	35 900	61 100	10 000
	KT 505825	80	50	58	25	44 900	81 500	10 000
	KT 505825N	66.3	50	58	25	51 400	97 800	10 000
	KT 505830	96.5	50	58	30	51 700	97 800	10 000
	KT 505835	113	50	58	35	58 300	114 000	10 000
52	KT 525817	41	52	58	17	28 300	56 000	9 500
	KT 526024	80	52	60	24	44 000	80 800	9 500



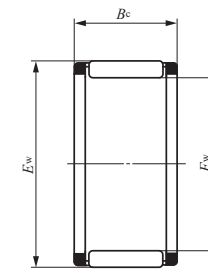


High carbon steel cage type

Shaft dia. 55 – 100mm

Shaft dia. mm	Identification number	Mass (Ref.) g	Boundary dimensions mm			Basic dynamic load rating <i>C</i> N	Basic static load rating <i>C</i> ₀ N	Allowable rotational speed ⁽¹⁾ min ⁻¹
			<i>F</i> _w	<i>E</i> _w	<i>B</i> _c			
55	KT 556020	42.5	55	60	20	28 600	66 000	9 000
	KT 556027	55.5	55	60	27	37 600	93 900	9 000
	KT 556120	52	55	61	20	32 600	68 500	9 000
	KT 556315	52.5	55	63	15	29 400	48 700	9 000
	KT 556320	71	55	63	20	37 400	66 400	9 000
	KT 556325	87	55	63	25	46 800	88 600	9 000
58	KT 586320	44.5	58	63	20	29 300	69 400	8 500
	KT 586420	54.5	58	64	20	33 600	72 500	8 500
60	KT 606520	45.5	60	65	20	29 700	71 100	8 500
	KT 606820	76.5	60	68	20	38 900	71 700	8 500
	KT 606825	94	60	68	25	48 600	95 600	8 500
	KT 606827	101	60	68	27	52 400	105 000	8 500
	KT 607236	205	60	72	36	86 700	152 000	8 500
63	KT 637120	79.5	63	71	20	39 500	74 400	8 000
65	KT 657320	83.5	65	73	20	41 200	79 600	7 500
	KT 657330	124	65	73	30	59 300	127 000	7 500
68	KT 687620	86.5	68	76	20	41 800	82 200	7 500
70	KT 707820	89	70	78	20	42 500	84 900	7 000
	KT 707830	132	70	78	30	61 200	136 000	7 000
72	KT 728020	91.5	72	80	20	43 200	87 500	7 000
75	KT 758320	94.5	75	83	20	43 800	90 200	6 500
	KT 758325	116	75	83	25	54 800	120 000	6 500
	KT 758330	141	75	83	30	63 100	144 000	6 500
	KT 758335	164	75	83	35	71 200	168 000	6 500

Note⁽¹⁾ Allowable rotational speed applies to oil lubrication. For grease lubrication, a maximum of 50% of this value is allowable.



KT

Shaft dia. mm	Identification number	Mass (Ref.) g	Boundary dimensions mm			Basic dynamic load rating <i>C</i> N	Basic static load rating <i>C</i> ₀ N	Allowable rotational speed ⁽¹⁾ min ⁻¹
			<i>F</i> _w	<i>E</i> _w	<i>B</i> _c			
80	KT 808822	110	80	88	22	49 700	108 000	6 000
	KT 808825	123	80	88	25	56 400	127 000	6 000
	KT 808830	149	80	88	30	65 000	153 000	6 000
85	KT 859112	44.5	85	91	12	25 200	56 700	6 000
	KT 859325	130	85	93	25	57 800	134 000	6 000
	KT 859330	157	85	93	30	66 600	161 000	6 000
90	KT 909825	138	90	98	25	60 400	145 000	5 500
	KT 909830	167	90	98	30	69 600	174 000	5 500
95	KT 9510330	175	95	103	30	70 900	182 000	5 500
100	KT 10010830	184	100	108	30	72 500	191 000	4 500

NEEDLE ROLLER CAGES FOR ENGINE CONNECTING RODS

- Needle Roller Cages for Big End
- Needle Roller Cages for Small End



Structure and Features

IKO Needle Roller Cages for Engine Connecting Rods are bearings for use in engine connecting rods. These bearings have superior performance proven in high performance engines of racing motor cycles, and are widely used in small motor vehicles, motor cycles, outboard marines, snow mobiles, high-speed compressors, etc. and also in general-purpose engines. Bearings for engine connecting rods are used under extremely severe and complex operating conditions such as heavy shock loads, high speeds, high temperatures and stringent lubrication. Needle Roller Cages for Engine Connecting Rods are lightweight, and have high load ratings and high rigidity as well as superior wear resistance to withstand these severe conditions.

Types

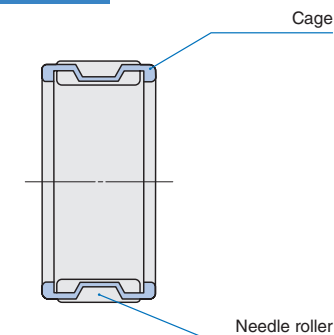
In Needle Roller Cages for Engine Connecting Rods, the types shown in Table 1 are available.

Table 1 Types

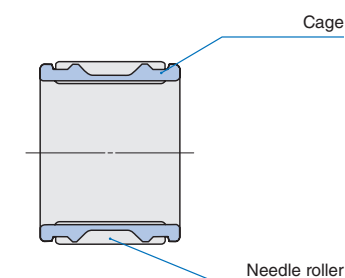
Type	For big end	For small end
Model code	KT...EG	KTV...EG

Structures of Needle Roller Cages for Engine Connecting Rods

KT...EG



KTV...EG



C
KT...EG
KTV...EG

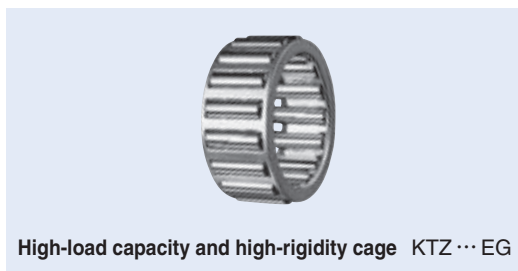
Needle Roller Cages for Big End KT...EG

These roller cages are subjected to acceleration and deceleration during their rotating and epicyclic motion due to crank shaft rotation. To withstand such conditions, they are made of a special alloy and are lightweight with high rigidity.

They are guided on their outer periphery surface with superior lubricating properties.

For the purpose of using them under severe conditions such as high rotational speed and stringent lubrication, bearings plated with non-ferrous metals are also available on request.

High-load capacity and high-rigidity cages to be used for racing motor cycles (See the photo below.), split needle cages for solid (one-piece) type crank-shafts and other special specification cages of various types are also available. Please consult IKO when required.



High-load capacity and high-rigidity cage KTZ...EG

Needle Roller Cages for Small End KTV...EG

These roller cages oscillates at high speeds within a limited loading zone under heavy shock loads. Thus, these cages are designed to be lightweight and have high rigidity with a well-balanced structure. In these cages, a number of needle rollers having a small diameter are incorporated to reduce the rolling contact stress in the loading zone.

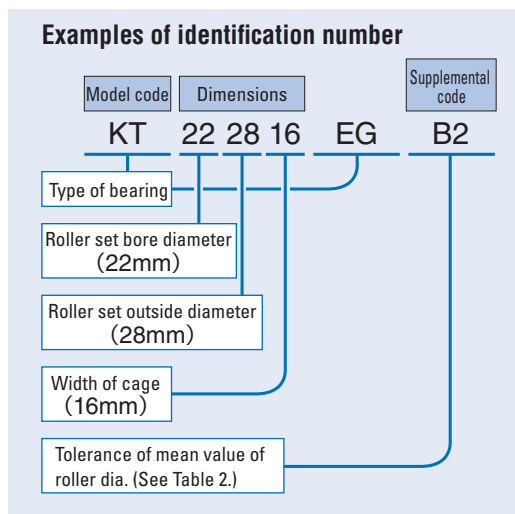
Needle Roller Cages for Small End are classified into two types, the outer surface guide type and the inner surface guide type. This classification is shown in the table of dimensions.

In the outer surface guide type, the cage is guided by the sliding contact between the inner surface of the connecting rod and the outer surface of the cage.

In the inner surface guide type, the cage is guided by the sliding contact between the outer surface of the pin and the inner surface of the cage.

Identification Number

The identification number of Needle Roller Cages for Engine Connecting Rods consists of a model code, dimensions and any supplemental codes as shown below.



Accuracy

The diameter tolerances of needle rollers of Needle Roller Cages for Engine Connecting Rods are classified as shown in Table 2. When the classification symbol is not indicated in the identification number, the classification symbol "B2" is applied.

The tolerance of the cage width B_c is $-0.2 \sim -0.4$ mm. But cages with marks in the B_c column in the dimension tables are manufactured with the following width tolerances.

- : $0 \sim -0.2$ mm
- : $-0.1 \sim -0.3$ mm

Table 2 Tolerances of needle roller diameter unit: μ m

Class	Classification symbol ⁽¹⁾	Tolerance of mean value of roller dia. ⁽²⁾
Standard	B 2	$0 \sim -2$
	B 4	$-2 \sim -4$
Semi-standard	B 6	$-4 \sim -6$
	B 8	$-6 \sim -8$
	B10	$-8 \sim -10$

Notes⁽¹⁾ The classification symbol is indicated at the end of the identification number.

⁽²⁾ Tolerances for circularity are based on JIS B 1506 (Rolling bearings - Rollers).

Clearance

Radial internal clearances are selected according to the type of engine and the operating conditions (rotational speed, load, lubricating conditions, etc.). If a bearing is used with an inadequate clearance, bearing troubles such as seizure, early flaking and noise increase may occur, leading to an engine failure. Therefore, it is necessary to select the clearance carefully according to test results and experience.

Recommended radial internal clearances are shown in Table 3. When operating at high speeds, it is recommended to select the upper limit of the clearance.

Fit

To obtain the recommended clearance shown in Table 3, it is general practice to match a connecting rod, crank pin or piston pin and needle roller cage of suitable tolerances for assembly.

Precautions for Use

When designing a connecting rod, crank pin and piston pin, the following precautions should be taken, because the raceways are subjected to loads under extremely severe conditions.

1 Material

It is recommended to use carburizing steel because the raceways are subjected to fluctuating loads with frequent and heavy shock loads. Generally, chromium molybdenum steel is used. Nickel chromium molybdenum steel is also used.

2 Hardness

The recommended surface hardness of the raceway is 697~800HV (60~64HRC). While the effective hardening depth differs depending on the applications, the general value is 0.6~1.2 mm.

3 Surface roughness

To minimize initial wear and to extend life, it is recommended that the surface roughness of the crank pin and piston pin be $0.1 \mu m R_a$ or less, and the surface roughness of the connecting rod large end and small end bores be $0.2 \mu m R_a$ or less.

4 Accuracy

Circularity and cylindricity of connecting rod, piston pin and crank pin are as shown in Table 4.

5 Parallelism and torsional accuracy of connecting rod bores

$L \pm 0.02$ mm and $E \pm 0.02$ mm shown in Fig. 1 indicate the parallelism and torsional accuracy between the big end and small end bores of the connecting rod, respectively. The tolerance range is 0.04 mm or less per 100 mm in case of a general-purpose engine and 0.02 mm or less for a high-speed engine such as a racing motorcycle engine. When these accuracy conditions are not satisfied, the axial forces on the needle roller cage and connecting rod will increase, directly leading to a failure such as seizure. Careful consideration is required.

Table 3 Recommended radial internal clearance unit: μ m

Shaft dia. mm		Big end	Small end
Over	Incl.		
—	18	$(d_p - 6) \sim d_p$	3 ~ 15
18	30	$(d_p - 8) \sim d_p$	
30	40	$(d_p - 12) \sim d_p$	

Remark d_p is obtained using the following equation for roller pitch circle diameter in millimeters, and changing the unit from millimeters to micrometers.

$$\text{Roller pitch circle dia.} = \frac{F_w + E_w}{2}$$

Example KT 222814 EG for big end
Recommended clearance is; $17 \sim 25 \mu$ m

Table 4 Accuracy of connecting rod, piston pin and crank pin unit: μ m

Range of dia. mm		Crank pin diameter d_1 Piston pin diameter d_2		Big end bore D_1 Small end bore D_2	
Over	Incl.	Circularity MAX.	Cylindricity MAX.	Circularity MAX.	Cylindricity MAX.
—	18	1	2	2	3
18	30	2	3	3	4
30	40	3	4	4	5

Remark Refer to Fig.1 for the dimension symbols.

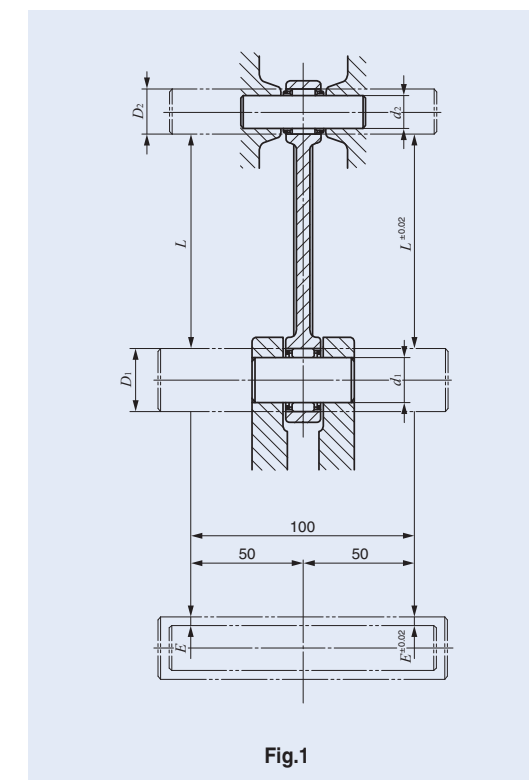
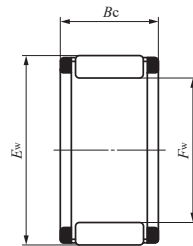


Fig.1

NEEDLE ROLLER CAGES FOR ENGINE CONNECTING RODS

Needle Roller Cages for Big End

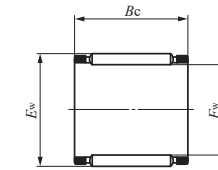


KT...EG

Shaft dia. 8 – 32mm

Shaft dia. mm	Identification number	Mass (Ref.) g	Boundary dimensions mm			Basic dynamic load rating C N	Basic static load rating C ₀ N	Cage guide type
			F _w	E _w	B _c			
8	KT 8128 EG	2.1	8	12	8	3 280	2 660	
10	KT 101410 EG	3.2	10	14	10	4 900	4 680	
12	KT 121610 EG	3.8	12	16	10	5 650	5 890	
	KT 121710 EG	5.3	12	17	10	6 670	6 380	
14	KT 14199.7 EG	5.7	14	19	9.7	6 120	5 880	
	KT 141910 EG	5.7	14	19	10	6 640	6 530	
15	KT 15199 EG	4.2	15	19	9	5 790	6 460	
	KT 152010 EG	6.1	15	20	10	7 100	7 260	
16	KT 162211.5 EG	9.5	16	22	■11.5	9 550	9 660	
	KT 162212 EG	9.7	16	22	12	10 500	10 900	
18	KT 182210 EG	5.7	18	22	10	7 500	9 560	
	KT 182411.6 EG	11	18	24	■11.6	10 600	11 500	
	KT 182412 EG	11	18	24	12	11 800	13 100	
20	KT 202612 EG	12	20	26	12	12 400	14 300	
	KT 202614 EG	13.8	20	26	14	13 000	15 200	
	KT 202814 EG	20	20	28	●14	15 700	16 100	
22	KT 222814 EG	14.9	22	28	14	13 600	16 600	
	KT 222816 EG	17.5	22	28	16	15 700	19 800	
	KT 222912 EG	15.2	22	29	12	12 900	14 000	
	KT 223215 EG	30	22	32	15	21 300	21 500	
23	KT 232913 EG	14.9	23	29	13	12 800	15 600	
24	KT 243015 EG	17.9	24	30	15	14 200	18 000	
	KT 243016 EG	18.2	24	30	16	16 300	21 500	
	KT 243120 EG	28	24	31	20	20 800	26 400	
30	KT 303818 EG	35.5	30	38	18	24 900	32 600	
32	KT 324220 EG	54	32	42	20	31 900	39 400	

Needle Roller Cages for Small End



KTV...EG

Shaft dia. 9 – 18mm

Shaft dia. mm	Identification number	Mass (Ref.) g	Boundary dimensions mm			Basic dynamic load rating C N	Basic static load rating C ₀ N	Cage guide type
			F _w	E _w	B _c			
9	KTV 91211.5 EG	2.8	9	12	●11.5	3 900	4 070	Outer surface guide
	KTV 91214 EG	3.5	9	12	14	4 440	4 810	Inner surface guide
10	KTV 101316 EG	4.5	10	13	16	4 400	4 880	Inner surface guide
	KTV 101410 EG	3.8	10	14	10	4 520	4 220	Inner surface guide
	KTV 101411 EG	4.1	10	14	11	5 060	4 880	Outer surface guide
	KTV 101412.5 EG	4.8	10	14	●12.5	5 590	5 540	Inner surface guide
10.5	KTV 10.51415 EG	5.1	10.5	14	15	5 710	6 270	Outer surface guide
12	KTV 121514.3 EG	4.3	12	15	●14.3	5 840	7 390	Outer surface guide
	KTV 121613 EG	5.6	12	16	13	7 020	7 800	Outer surface guide
	KTV 121615.5 EG	6.8	12	16	●15.5	7 600	8 600	Outer surface guide
14	KTV 141812 EG	6	14	18	12	6 780	7 760	Inner surface guide
	KTV 141816.5 EG	8.2	14	18	16.5	9 180	11 500	Outer surface guide
	KTV 141822 EG	10.8	14	18	●22	9 950	12 600	Inner surface guide
16	KTV 162019 EG	10.6	16	20	19	10 800	14 600	Outer surface guide
	KTV 162022 EG	12.7	16	20	22	11 400	15 700	Inner surface guide
18	KTV 182223.5 EG	14.9	18	22	■23.5	13 000	19 300	Inner surface guide
	KTV 182321 EG	16.4	18	23	21	14 400	18 900	Inner surface guide

MACHINED TYPE NEEDLE ROLLER BEARINGS

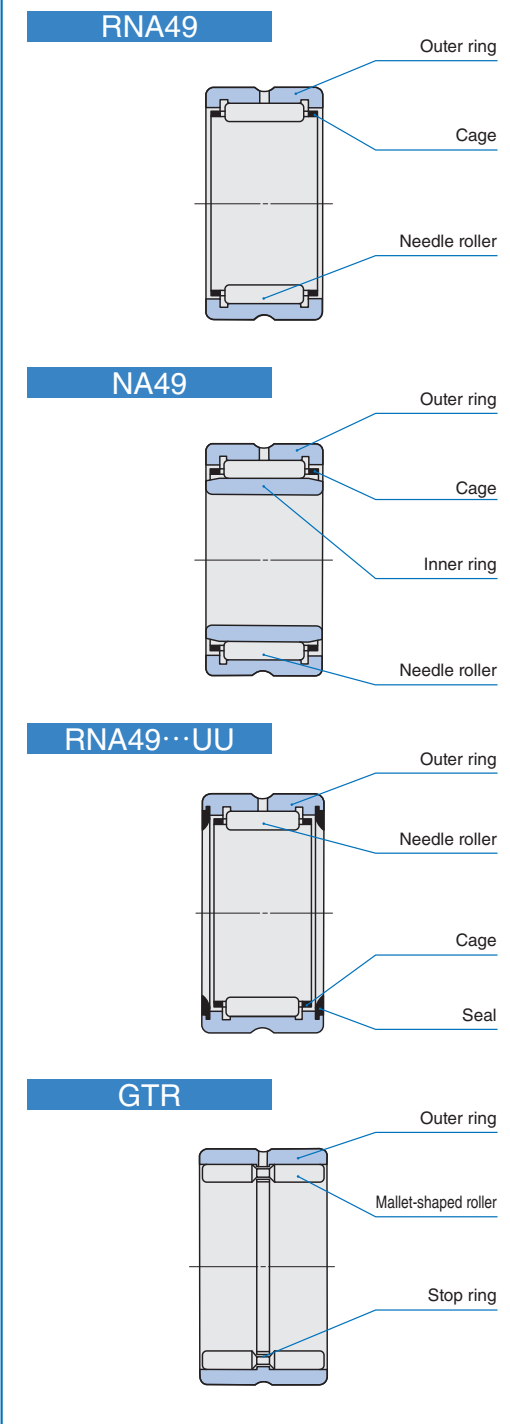
- Machined Type Caged Needle Roller Bearings
- Machined Type Guide Needle Roller Bearings



Structure and Features

IKO Machined Type Needle Roller Bearings are bearings with a low sectional height and large load ratings. The outer ring has high rigidity and can easily be used even for light alloy housings. These bearings are available in metric series and inch series, both of which have the caged type and the full complement type. It is therefore possible to select a suitable bearing for use under various conditions such as heavy loads and high-speed or low-speed rotations. In addition, there are bearings with and without an inner ring. As the type without inner ring uses a shaft as the raceway surface, a compact design is possible.

Structures of Machined Type Needle Roller Bearings



Types

Machined Type Needle Roller Bearings are available in various types shown in Table 1.

Table 1.1 Type of bearing (Standard type)

Series	Caged Needle Roller Bearings		Guide Needle Roller Bearings	
	Without inner ring	With inner ring ⁽¹⁾	Without inner ring	With inner ring ⁽¹⁾
Dimension series 49	RNA 49	NA 49	GTR	GTRI
Dimension series 69	RNA 69	NA 69		
Dimension series 48	RNA 48	NA 48		
For heavy duty	TR	TRI		
For light duty	TAF	TAFI		
Inch series	BR	BRI	—	—

Table 1.2 Type of bearing (With seal)

Series	Caged Needle Roller Bearings		Guide Needle Roller Bearings	
	Without inner ring	With inner ring ⁽¹⁾	Without inner ring	With inner ring ⁽¹⁾
Metric series	Two side seals	RNA 49···UU	NA 49···UU	—
	One side seal	RNA 49···U	NA 49···U	
Metric series	Two side seals	RNA 69···UU	NA 69···UU	—
	One side seal	RNA 69···U	NA 69···U	
Inch series	Two side seals	BR ···UU	BRI ···UU	—
	One side seal	—	—	—

Note⁽¹⁾ For Machined Type Needle Roller Bearings with Inner Rings, the Needle Roller Bearings and Inner Rings will be delivered separately. If product is needed as one unit, please contact IKO.

Caged Needle Roller Bearings

This type of bearing combines a collared outer ring with the IKO's unique lightweight rigid cage and needle rollers. During operation, needle rollers are guided precisely by the cage, and an ideal load distribution is obtained.

The metric series consists of the NA48 and NA49 series of ISO Standard, NA69 and TAFI series which are based on the international dimension series, and the heavy duty TRI series which is widely used in Japan. The TAFI series has a sectional height as low as that of the shell type and is used for light loads.

The inch series or BRI series is based on the specifications of ANSI Standard of USA.

Caged Needle Roller Bearings without Inner Ring

As shown in the section "Design of shaft and housing" on page A44, any desired radial clearance can be selected by assembling this type of bearing with a shaft which is heat-treated and finished by grinding. These bearings are free from the effects on dimensional accuracy caused by assembling an inner ring,

so that the rotational accuracy is improved. Also, the shaft rigidity can be improved as the shaft diameter can be increased by an amount corresponding to the inner ring thickness.

Caged Needle Roller Bearings with Inner Ring

This type of bearing is used when the shaft cannot be heat-treated and finished by grinding. The outer and inner rings are separable and a small relief clearance is provided on both sides of the inner ring raceway to facilitate bearing mounting. In the TRI and BRI series, the width of the inner ring is larger than that of the outer ring.

Due to heat expansion during operation or mounting errors, the inner or outer ring may be shifted axially and the whole length of the rollers may not be in contact with the raceway. Therefore, attention should be paid to the allowable axial shift *S* as shown in the table of dimensions.

Needle Roller Bearings with Seal

These bearings are sealed types of the NA49, NA69 and BRI series bearings, in which a seal is installed on one side (type with one seal) or both sides (type with two seals) of the bearing. The seal is made of special synthetic rubber and effectively prevents dust penetration and grease leakage.

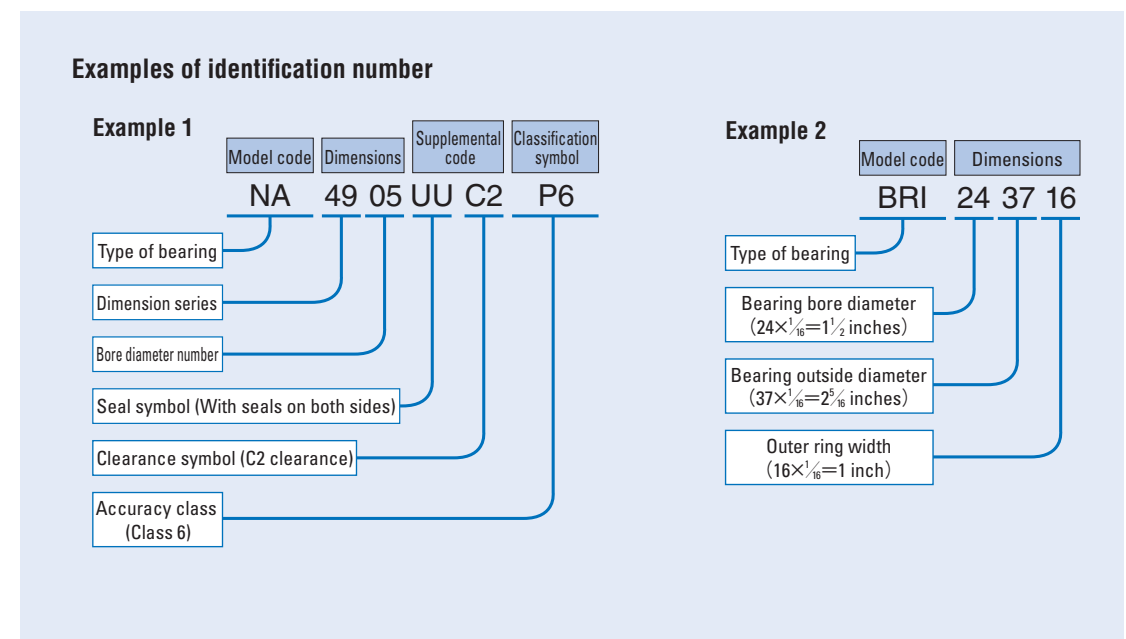
Guide Needle Roller Bearings

These bearings are full complement type bearings and use mallet-shaped rollers which are guided accurately by the guide rail located at the center of the outer ring raceway and the guide groove of the mallet-shaped roller. This minimizes skewing (tilting of the roller from its rotating axis), which is normally a weak point of full complement bearings, and improves the rotational accuracy. This type of bearing is especially suitable for heavy loads, shock loads and oscillating motions.

Bearings with and without inner rings are available. In bearings with an inner ring, the width of the inner ring is larger than that of the outer ring.

Identification Number

The identification number of Machined Type Needle Roller Bearings consists of a model code, dimensions, any supplemental codes and a classification symbol. Examples are shown below.



Accuracy

Machined Type Needle Roller Bearings are manufactured based on JIS (See page A31.). The tolerances for the smallest single roller set bore diameter of bearings without inner ring are based on Table 14 on page A33. For BR and BRI series, the accuracy is based on Table 2 and the tolerances for the smallest single roller set bore diameter are based on Table 3.

Table 2 Accuracy of inner and outer rings of inch series BR and BRII

unit: μ m

<i>d</i> or <i>D</i> Nominal bearing bore dia. or outside dia. mm		Δ_{dmp} Single plane mean bore diameter deviation		Δ_{Dmp} Single plane mean outside diameter deviation		Δ_{Bs} (Δ_{Cs}) Deviation of a single inner (or outer) ring width		K_{ia} Radial runout of assembled bearing inner ring	K_{ea} Radial runout of assembled bearing outer ring
Over	Incl.	High	Low	High	Low	High	Low	Max.	Max.
—	19.050	0	− 10	—	—	0	− 130	10	—
19.050	30.162	0	− 13	0	− 13	0	− 130	13	15
30.162	50.800	0	− 13	0	− 13	0	− 130	15	20
50.800	82.550	0	− 15	0	− 15	0	− 130	20	25
82.550	120.650	0	− 20	0	− 20	0	− 130	25	35
120.650	184.150	—	—	0	− 25	0	− 130	30	45

Remark *d* for Δ_{dmp} , Δ_{Bs} , Δ_{Cs} and K_{ia} , and *D* for Δ_{Dmp} and K_{ea}

Table 3 Tolerances for smallest single roller set bore diameter $F_{ws\ min}$ of inch series BR unit: μm

F_w Nominal roller set bore diameter mm		$\Delta F_{ws\ min}$ Deviation of smallest single roller set bore diameter	
Over	Incl.	High	Low
—	18.034	+ 43	+ 20
18.034	30.226	+ 46	+ 23
30.226	41.910	+ 48	+ 25
41.910	50.038	+ 51	+ 25
50.038	70.104	+ 53	+ 28
70.104	80.010	+ 58	+ 28
80.010	102.108	+ 61	+ 31

Clearance

Radial internal clearances of Machined Type Needle Roller Bearings are made to the CN clearance shown in Table 18 on page A37. Radial internal clearances of BRI series are based on Table 4.

Table 4 Radial internal clearance of inch series BRI unit: μm

F_w Nominal roller set bore diameter mm		Radial internal clearance	
Over	Incl.	Min.	Max.
—	18.034	33	66
18.034	25.908	41	76
25.908	30.226	46	82
30.226	35.052	48	86
35.052	41.910	50	89
41.910	50.038	50	92
50.038	70.104	56	99
70.104	80.010	56	104
80.010	100.076	63	117
100.076	102.108	68	127

Table 6.1 Number of oil holes of the outer ring

Bearing type			Number of oil holes of the outer ring			
Nominal roller set bore diameter F_w mm			Standard type	With seals on both sides	With a seal on one side	
Caged Needle Roller Bearings	Metric series	RNA, NA	1	1	1	
		TR, TRI	1	—	—	
		TAF, TAFI	0	—	—	
	Inch series	BR, BRI	$F_w \leq 26$	1	—	—
			$26 < F_w$	1	—	—
		BR, BRI	$F_w \leq 69.850$	1	1	—
		$69.850 < F_w$	2	1	—	
Guide Needle Roller Bearings	Metric series	GTR, GTRI	1	—	—	

Remark The type with an oil hole(s) is provided with an oil groove.

Fit

The recommended fits for Machined Type Needle Roller Bearings are shown in Tables 22 to 24 on pages A41 and A42.

Lubrication

Bearings with prepacked grease are shown in Table 5. ALVANIA GREASE S2 (Shell Lubricants Japan K.K.) is prepacked as the lubricating grease. In the case of bearings without prepacked grease, perform proper lubrication. Operating them without lubrication will increase the wear of the rolling contact surfaces and shorten their lives.

Table 5 Bearings with prepacked grease O: With prepacked grease X: Without prepacked grease

Bearing type			Standard type	With seals on both sides	With a seal on one side
Caged Needle Roller Bearings	Metric series	RNA, NA	X	O	X
		TR, TRI	X	—	—
		TAF, TAFI, TAF/SG	X	—	—
Guide Needle Roller Bearings	Metric series	BR, BRI	X	O	—
		GTR, GTRI	X	—	—

Oil Hole

Table 6.1 shows the number of oil holes of the outer ring and Table 6.2 shows the number of oil holes of the inner ring.

When an outer ring with an oil hole is especially required for the type without an oil hole, add "—OH" before the clearance symbol in the identification number. When an outer ring with an oil hole and an oil groove is required for the type without an oil hole, attach "—OG" before the clearance symbol.

Example: TAFI 203216 — OH C2 P6

When an outer ring with multiple oil holes or an inner ring with an oil hole(s) is required, please consult IKO.

Table 6.2 Number of oil holes of the inner ring

Bearing type			Number of oil holes of the inner ring		
Nominal bearing bore diameter d mm			Standard type	With seals on both sides	With a seal on one side
Caged Needle Roller Bearings	Metric series	NA	0	0	0
		TRI	0	0	0
		TAFI	0	—	—
	Inch series	BRI	$d \leq 76.200$	1	1
$76.200 < d$			2	1	—
Guide Needle Roller Bearings	Metric series	GTRI	0	—	—

Remark The type with an oil hole(s) is provided with an oil groove.

Matched Set Bearings

When using two or more Machined Type Needle Roller Bearings adjacent to each other on the same shaft, it is necessary to obtain an even load distribution. On request, a set of bearings is available, in which bearings are matched to obtain an even load distribution.

Mounting

Mounting dimensions for Machined Type Needle Roller Bearings are shown in the table of dimensions.

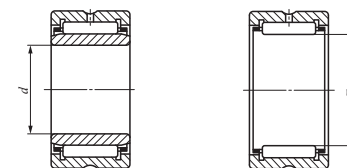
Extended Life Specification Machined Type Needle Roller Bearings

Extended Life Specification Machined Type Needle Roller Bearings are treated with a newly developed special heat treatment that enhances the bearing's surface hardness and toughness, and suppresses the generation and growth of damage on the surface. Significant life extension can be achieved under high load or under the condition of lubrication contaminated with foreign substances.

In a life comparison test, as shown in Figure 1, IKO's special heat treated Extended Life Specification products lasted 5 times longer than standard heat-treated products.

Extended Life Specification Machined Type Needle Roller Bearings, available according to the "Applicable Production Size" shown in Table 7, are made to order upon request.

Table 7 Applicable Production Size



With inner ring $d=10 \sim 75\text{mm}$	Without inner ring $F_w=14 \sim 85\text{mm}$
NA 4900 ~ 4915	RNA 4900 ~ 4915
NA 6901 ~ 6915	RNA 6901 ~ 6915
TAFI 102216 ~ 7510535	TAF 142216 ~ 8510535
TRI 153320 ~ 7510845	TR 203320 ~ 8310845

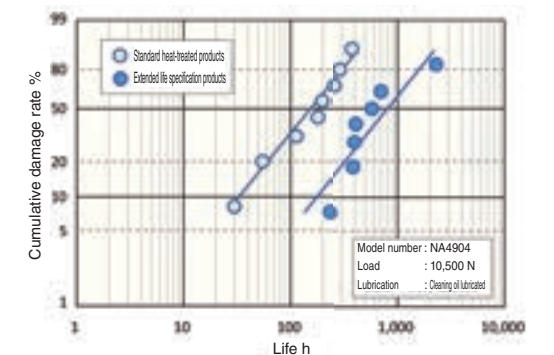
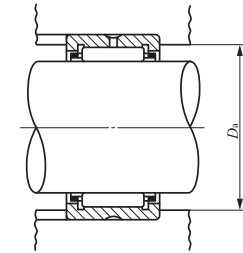
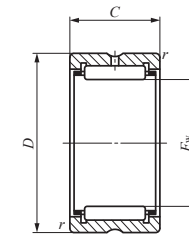


Fig. 1 Life Test Result

Remark This table shows the result of life testing under load conditions at 50% of the basic dynamic rating. The Extended Life Specification with special heat treatment lasted 5 times longer or more in L10 life compared to the standard heat-treated products.

MACHINED TYPE NEEDLE ROLLER BEARINGS

Without Inner Ring



RNA49 TAF
RNA69 ($F_w \leq 35$)

Shaft dia. 5 – 15mm

Shaft dia. mm	Identification number						Mass (Ref.) g
	RNA 49	RNA 69	RNA 48	TAF	TR	GTR	
5	—	—	—	TAF 51010	—	—	3.4
	—	—	—	TAF 51012	—	—	4.2
	RNA 493	—	—	—	—	—	4.6
6	RNA 494	—	—	—	—	—	5.3
	—	—	—	TAF 61212	—	—	6.4
7	RNA 495	—	—	—	—	—	5.9
	—	—	—	TAF 71410	—	—	6.9
	—	—	—	TAF 71412	—	—	8.3
8	RNA 496	—	—	—	—	—	7.4
	—	—	—	TAF 81512	—	—	9.1
	—	—	—	TAF 81516	—	—	12.9
9	—	—	—	TAF 91612	—	—	9.8
	—	—	—	TAF 91616	—	—	13.2
	RNA 497	—	—	—	—	—	9.3
10	—	—	—	TAF 101712	—	—	10.7
	—	—	—	TAF 101716	—	—	14.3
	RNA 498	—	—	—	—	—	12.6
12	—	—	—	TAF 121912	—	—	12.2
	—	—	—	TAF 121916	—	—	16.3
	RNA 499	—	—	—	—	—	13.6
14	RNA 4900	—	—	—	—	—	16.5
	—	—	—	TAF 142216	—	—	21
	—	—	—	TAF 142220	—	—	26.5
15	—	—	—	TAF 152316	—	—	22.5
	—	—	—	TAF 152320	—	—	28

Notes⁽¹⁾ Minimum allowable value of chamfer dimension r
⁽²⁾ Allowable rotational speed applies to oil lubrication. For grease lubrication, a maximum of 60% of this value is allowable.
 Remarks1. TAF series with a roller set bore diameter F_w of 26 mm or less have no oil hole. In others, the outer ring has an oil groove and an oil hole.
 2. No grease is prepacked. Perform proper lubrication.

Boundary dimensions mm				Standard mounting dimension	Basic dynamic load rating	Basic static load rating	Allowable rotational speed ⁽²⁾
F_w	D	C	$r_{s \min}^{(1)}$	D_a Max. mm	C N	C_0 N	min ⁻¹
5	10	10	0.2	8.4	2 420	1 950	80 000
5	10	12	0.2	8.4	3 080	2 660	80 000
5	11	10	0.15	9.8	2 420	1 950	80 000
6	12	10	0.15	10.8	2 700	2 320	70 000
6	12	12	0.2	10.4	3 440	3 170	70 000
7	13	10	0.15	11.8	2 960	2 690	60 000
7	14	10	0.2	12.4	3 600	2 960	60 000
7	14	12	0.2	12.4	4 610	4 050	60 000
8	15	10	0.15	13.8	3 960	3 420	50 000
8	15	12	0.2	13.4	5 060	4 690	50 000
8	15	16	0.2	13.4	7 080	7 220	50 000
9	16	12	0.2	14.4	5 490	5 330	45 000
9	16	16	0.2	14.4	7 680	8 210	45 000
9	17	10	0.15	15.8	4 530	3 650	45 000
10	17	12	0.2	15.4	5 880	5 970	40 000
10	17	16	0.2	15.4	8 230	9 190	40 000
10	19	11	0.2	17.4	6 180	5 030	40 000
12	19	12	0.3	17	6 610	7 260	35 000
12	19	16	0.3	17	9 250	11 200	35 000
12	20	11	0.3	18	6 600	6 310	35 000
14	22	13	0.3	20	9 230	10 100	30 000
14	22	16	0.3	20	11 700	13 700	30 000
14	22	20	0.3	20	14 800	18 600	30 000
15	23	16	0.3	21	12 300	14 900	30 000
15	23	20	0.3	21	15 600	20 200	30 000

MACHINED TYPE NEEDLE ROLLER BEARINGS

Without Inner Ring



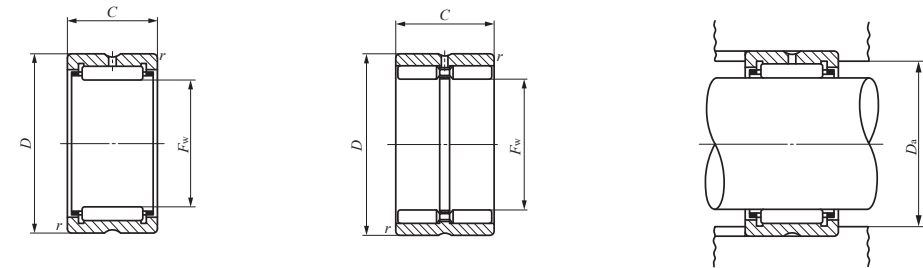
Shaft dia. 16 – 22mm

Shaft dia. mm	Identification number						Mass (Ref.) g
	RNA 49	RNA 69	RNA 48	TAF	TR	GTR	
16	RNA 4901	—	—	—	—	—	18.1
	—	—	—	TAF 162416	—	—	23
	—	—	—	TAF 162420	—	—	29
	—	RNA 6901	—	—	—	—	30
17	—	—	—	TAF 172516	—	—	24.5
	—	—	—	TAF 172520	—	—	30.5
18	RNA 49/14	—	—	—	—	—	19.9
	—	—	—	TAF 182616	—	—	25.5
	—	—	—	TAF 182620	—	—	32
19	—	—	—	TAF 192716	—	—	27
	—	—	—	TAF 192720	—	—	34
20	RNA 4902	—	—	—	—	—	21.5
	—	—	—	TAF 202816	—	—	27.5
	—	—	—	TAF 202820	—	—	35.5
	—	RNA 6902	—	—	—	—	37
	—	—	—	—	TR 203320	—	59.5
	—	—	—	—	—	GTR 203320	69
21	—	—	—	TAF 212916	—	—	29
	—	—	—	TAF 212920	—	—	36
22	RNA 4903	—	—	—	—	—	23.5
	—	—	—	TAF 223016	—	—	30
	—	—	—	TAF 223020	—	—	37.5
	—	RNA 6903	—	—	—	—	40.5
	—	—	—	—	TR 223425	—	73.5
—	—	—	—	—	GTR 223425	87	

Notes⁽¹⁾ Minimum allowable value of chamfer dimension *r*
⁽²⁾ Allowable rotational speed applies to oil lubrication. For grease lubrication, a maximum of 60% of this value is allowable.

Remarks1. TAF series with a roller set bore diameter F_w of 26 mm or less have no oil hole. In others, the outer ring has an oil groove and an oil hole.

2. No grease is prepacked. Perform proper lubrication.



RNA49 TAF TR
RNA69 ($F_w \leq 35$)

GTR

Boundary dimensions mm				Standard mounting dimension	Basic dynamic load rating	Basic static load rating	Allowable rotational speed ⁽²⁾ min ⁻¹
F_w	<i>D</i>	<i>C</i>	$r_{s \min}^{(1)}$	<i>D_a</i> Max. mm	<i>C</i> N	<i>C₀</i> N	
16	24	13	0.3	22	9 660	11 100	25 000
16	24	16	0.3	22	12 300	15 100	25 000
16	24	20	0.3	22	15 500	20 400	25 000
16	24	22	0.3	22	17 100	23 000	25 000
17	25	16	0.3	23	12 900	16 300	25 000
17	25	20	0.3	23	16 300	22 000	25 000
18	26	13	0.3	24	10 600	12 800	20 000
18	26	16	0.3	24	13 400	17 500	20 000
18	26	20	0.3	24	17 000	23 600	20 000
19	27	16	0.3	25	14 000	18 700	20 000
19	27	20	0.3	25	17 700	25 300	20 000
20	28	13	0.3	26	10 900	13 800	20 000
20	28	16	0.3	26	13 900	18 800	20 000
20	28	20	0.3	26	17 600	25 400	20 000
20	28	23	0.3	26	19 300	28 800	20 000
20	33	20	0.3	31	24 300	26 500	20 000
20	33	20	0.3	31	29 200	37 200	7 500
21	29	16	0.3	27	14 400	20 000	19 000
21	29	20	0.3	27	18 200	27 100	19 000
22	30	13	0.3	28	11 700	15 600	18 000
22	30	16	0.3	28	14 900	21 200	18 000
22	30	20	0.3	28	18 900	28 700	18 000
22	30	23	0.3	28	20 800	32 500	18 000
22	34	25	0.3	32	29 100	36 800	18 000
22	34	25	0.3	32	37 900	57 800	7 000

D

NA
TAFI
TRI
BRI

MACHINED TYPE NEEDLE ROLLER BEARINGS

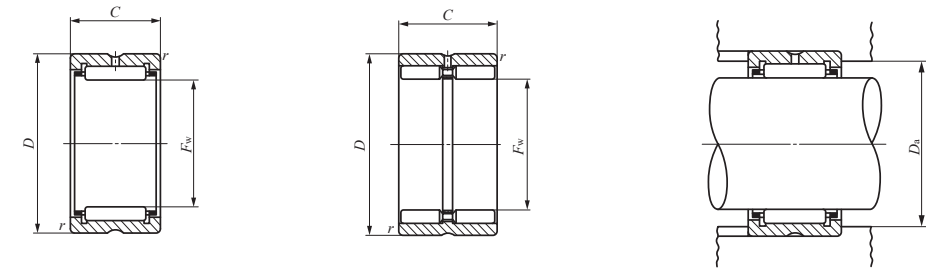
Without Inner Ring



Shaft dia. 24 – 30mm

Shaft dia. mm	Identification number						Mass (Ref.) g
	RNA 49	RNA 69	RNA 48	TAF	TR	GTR	
24	—	—	—	TAF 243216	—	—	32
	—	—	—	TAF 243220	—	—	40.5
25	—	—	—	TAF 253316	—	—	33.5
	—	—	—	TAF 253320	—	—	42
	RNA 4904	—	—	—	—	—	55.5
	—	RNA 6904	—	—	—	—	95.5
	—	—	—	—	TR 253820	—	71
	—	—	—	—	TR 253825	—	89
26	—	—	—	TAF 263416	—	—	34.5
	—	—	—	TAF 263420	—	—	43.5
28	—	—	—	TAF 283720	—	—	51.5
	—	—	—	TAF 283730	—	—	83.5
	RNA 49/22	—	—	—	—	—	56.5
	—	RNA 69/22	—	—	—	—	97.5
29	—	—	—	TAF 293820	—	—	57
	—	—	—	TAF 293830	—	—	85
30	—	—	—	TAF 304020	—	—	64.5
	—	—	—	TAF 304030	—	—	97.5
	RNA 4905	—	—	—	—	—	64
	—	RNA 6905	—	—	—	—	111
	—	—	—	—	TR 304425	—	115
	—	—	—	—	—	GTR 304425	133

Notes⁽¹⁾ Minimum allowable value of chamfer dimension *r*
⁽²⁾ Allowable rotational speed applies to oil lubrication. For grease lubrication, a maximum of 60% of this value is allowable.
 Remarks1. TAF series with a roller set bore diameter F_w of 26 mm or less have no oil hole. In others, the outer ring has an oil groove and an oil hole.
 2. No grease is prepacked. Perform proper lubrication.



RNA49 TAF TR
RNA69 ($F_w \leq 35$)

GTR

F_w	Boundary dimensions mm			Standard mounting dimension D_a Max. mm	Basic dynamic load rating C N	Basic static load rating C_0 N	Allowable rotational speed ⁽²⁾ min ⁻¹
	D	C	$r_{s \text{ min}}^{(1)}$				
24	32	16	0.3	30	15 300	22 500	17 000
24	32	20	0.3	30	19 400	30 500	17 000
25	33	16	0.3	31	15 800	23 700	16 000
25	33	20	0.3	31	20 000	32 100	16 000
25	37	17	0.3	35	21 000	25 000	16 000
25	37	30	0.3	35	35 400	48 900	16 000
25	38	20	0.3	36	28 900	35 000	16 000
25	38	25	0.3	36	34 800	44 400	16 000
25	38	20	0.3	36	33 300	46 500	6 000
25	38	25	0.3	36	42 400	63 700	6 000
26	34	16	0.3	32	16 300	24 900	15 000
26	34	20	0.3	32	20 600	33 800	15 000
28	37	20	0.3	35	21 700	37 100	14 000
28	37	30	0.3	35	31 100	58 900	14 000
28	39	17	0.3	37	21 400	28 900	14 000
28	39	30	0.3	37	36 300	56 900	14 000
29	38	20	0.3	36	21 600	37 200	14 000
29	38	30	0.3	36	30 900	59 100	14 000
30	40	20	0.3	38	25 100	40 100	13 000
30	40	30	0.3	38	36 000	63 900	13 000
30	42	17	0.3	40	23 700	30 700	13 000
30	42	30	0.3	40	42 100	64 300	13 000
30	44	25	0.3	42	37 900	52 100	13 000
30	44	25	0.3	42	47 000	76 500	5 000

D
NA
TAFI
TRI
BRI

MACHINED TYPE NEEDLE ROLLER BEARINGS

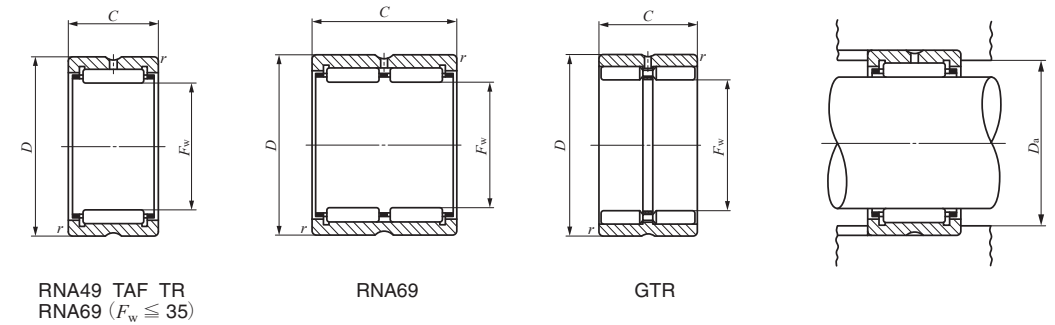
Without Inner Ring



Shaft dia. 32 – 40mm

Shaft dia. mm	Identification number						Mass (Ref.) g
	RNA 49	RNA 69	RNA 48	TAF	TR	GTR	
32	—	—	—	TAF 324220	—	—	68
	—	—	—	TAF 324230	—	—	102
	RNA 49/28	—	—	—	—	—	76.5
	—	RNA 69/28	—	—	—	—	133
	—	—	—	—	—	GTR 324530	152
35	—	—	—	TAF 354520	—	—	73.5
	—	—	—	TAF 354530	—	—	112
	RNA 4906	—	—	—	—	—	72.5
	—	RNA 6906	—	—	—	—	125
	—	—	—	—	TR 354830	—	139
	—	—	—	—	—	GTR 354830	163
37	—	—	—	TAF 374720	—	—	77.5
	—	—	—	TAF 374730	—	—	117
38	—	—	—	TAF 384820	—	—	79
	—	—	—	TAF 384830	—	—	119
	—	—	—	—	TR 385230	—	168
	—	—	—	—	—	GTR 385230	195
40	—	—	—	TAF 405020	—	—	83
	—	—	—	TAF 405030	—	—	125
	RNA 49/32	—	—	—	—	—	96
	—	RNA 69/32	—	—	—	—	172
	—	—	—	—	TR 405520	—	129
	—	—	—	—	—	GTR 405520	144

Notes⁽¹⁾ Minimum allowable value of chamfer dimension *r*
⁽²⁾ Allowable rotational speed applies to oil lubrication. For grease lubrication, a maximum of 60% of this value is allowable.
 Remarks1. The outer ring has an oil groove and an oil hole.
 2. No grease is prepacked. Perform proper lubrication.



Boundary dimensions mm				Standard mounting dimension	Basic dynamic load rating	Basic static load rating	Allowable rotational speed ⁽²⁾ min ⁻¹
<i>F_w</i>	<i>D</i>	<i>C</i>	<i>r_s</i> min ⁽¹⁾	<i>D_a</i> Max. mm	<i>C</i> N	<i>C₀</i> N	
32	42	20	0.3	40	25 700	42 200	12 000
32	42	30	0.3	40	36 800	67 200	12 000
32	45	17	0.3	43	24 500	32 700	12 000
32	45	30	0.3	43	41 800	64 800	12 000
32	45	30	0.3	43	58 000	101 000	4 500
35	45	20	0.3	43	26 900	46 200	11 000
35	45	30	0.3	43	38 600	73 600	11 000
35	47	17	0.3	45	25 200	34 700	11 000
35	47	30	0.3	45	43 000	69 000	11 000
35	48	30	0.3	46	47 400	72 300	11 000
35	48	30	0.3	46	61 100	110 000	4 500
37	47	20	0.3	45	28 200	50 100	11 000
37	47	30	0.3	45	40 500	79 800	11 000
38	48	20	0.3	46	28 100	50 200	11 000
38	48	30	0.3	46	40 300	80 000	11 000
38	52	30	0.6	48	50 800	81 100	11 000
38	52	30	0.6	48	64 200	121 000	4 000
40	50	20	0.3	48	29 400	54 100	10 000
40	50	30	0.3	48	42 300	86 200	10 000
40	52	20	0.6	48	31 200	47 800	10 000
40	52	36	0.6	48	53 500	95 700	10 000
40	55	20	0.6	51	37 400	55 700	10 000
40	55	20	0.6	51	44 300	73 600	3 500

D
NA
TAFI
TRI
BRI

MACHINED TYPE NEEDLE ROLLER BEARINGS

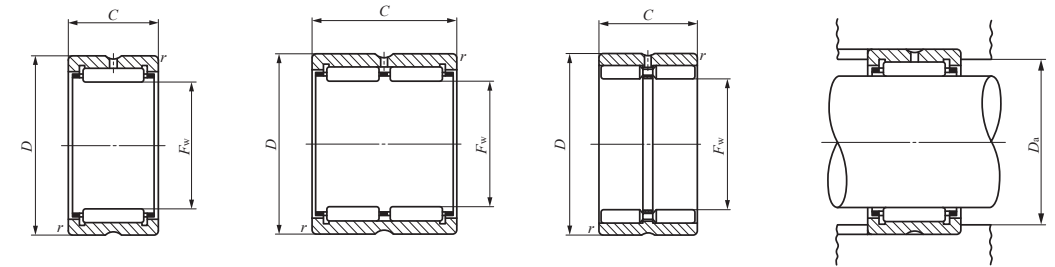
Without Inner Ring



Shaft dia. 42 – 50mm

Shaft dia. mm	Identification number						Mass (Ref.) g
	RNA 49	RNA 69	RNA 48	TAF	TR	GTR	
42	—	—	—	TAF 425220	—	—	86.5
	—	—	—	TAF 425230	—	—	130
	RNA 4907	—	—	—	—	—	113
	—	RNA 6907	—	—	—	—	200
42	—	—	—	—	TR 425630	—	183
	—	—	—	—	—	GTR 425630	210
43	—	—	—	TAF 435320	—	—	88.5
	—	—	—	TAF 435330	—	—	133
45	—	—	—	TAF 455520	—	—	92
	—	—	—	TAF 455530	—	—	138
	RNA 49/38	—	—	—	—	—	120
	—	—	—	—	TR 455930	—	193
45	—	—	—	—	—	GTR 455930	225
	—	—	—	TAF 475720	—	—	95
47	—	—	—	TAF 475730	—	—	144
	RNA 4908	—	—	—	—	—	152
48	—	—	—	—	TR 486230	—	205
	—	RNA 6908	—	—	—	—	275
	—	—	—	—	—	GTR 486230	240
	—	—	—	TAF 506225	—	—	159
50	—	—	—	TAF 506235	—	—	225
	—	—	—	—	TR 506430	—	210
	RNA 49/42	—	—	—	—	—	174
	—	—	—	—	—	GTR 506430	245
	—	—	—	—	—	—	245

Notes⁽¹⁾ Minimum allowable value of chamfer dimension *r*
⁽²⁾ Allowable rotational speed applies to oil lubrication. For grease lubrication, a maximum of 60% of this value is allowable.
 Remarks1. The outer ring has an oil groove and an oil hole.
 2. No grease is prepacked. Perform proper lubrication.



RNA49 TAF TR

RNA69

GTR

Boundary dimensions mm				Standard mounting dimension	Basic dynamic load rating	Basic static load rating	Allowable rotational speed ⁽²⁾
<i>F_w</i>	<i>D</i>	<i>C</i>	<i>r_s</i> min ⁽¹⁾	<i>D_a</i> Max. mm	<i>C</i> N	<i>C₀</i> N	min ⁻¹
42	52	20	0.3	50	29 900	56 200	9 500
42	52	30	0.3	50	43 000	89 400	9 500
42	55	20	0.6	51	32 000	50 100	9 500
42	55	36	0.6	51	54 900	100 000	9 500
42	56	30	0.6	52	53 800	90 100	9 500
42	56	30	0.6	52	67 500	133 000	3 500
43	53	20	0.3	51	30 500	58 200	9 500
43	53	30	0.3	51	43 800	92 600	9 500
45	55	20	0.3	53	31 000	60 200	9 000
45	55	30	0.3	53	44 600	95 800	9 000
45	58	20	0.6	54	33 600	54 600	9 000
45	59	30	0.6	55	55 100	94 800	9 000
45	59	30	0.6	55	70 300	142 000	3 500
47	57	20	0.3	55	31 500	62 200	8 500
47	57	30	0.3	55	45 200	99 100	8 500
48	62	22	0.6	58	41 600	67 400	8 500
48	62	30	0.6	58	56 300	99 500	8 500
48	62	40	0.6	58	71 300	135 000	8 500
48	62	30	0.6	58	72 700	154 000	3 000
50	62	25	0.3	60	43 000	85 300	8 000
50	62	35	0.3	60	58 000	125 000	8 000
50	64	30	0.6	60	57 700	104 000	8 000
50	65	22	0.6	61	42 500	70 300	8 000
50	64	30	0.6	60	74 600	158 000	3 000

D
NA
TAFI
TRI
BRI

MACHINED TYPE NEEDLE ROLLER BEARINGS

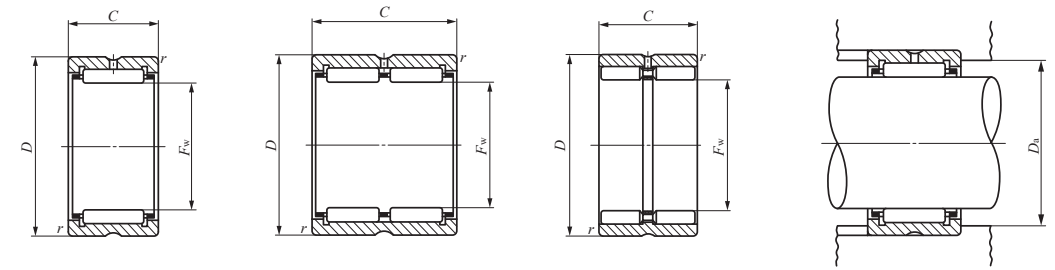
Without Inner Ring



Shaft dia. 52 – 68mm

Shaft dia. mm	Identification number						Mass (Ref.) g
	RNA 49	RNA 69	RNA 48	TAF	TR	GTR	
52	RNA 4909	—	—	—	—	—	197
	—	RNA 6909	—	—	—	—	355
55	—	—	—	TAF 556825	—	—	193
	—	—	—	TAF 556835	—	—	255
	RNA 49/48	—	—	—	—	—	188
58	RNA 4910	—	—	—	—	—	179
	—	RNA 6910	—	—	—	—	320
60	—	—	—	TAF 607225	—	—	187
	—	—	—	TAF 607235	—	—	260
	RNA 49/52	—	—	—	—	—	205
62	—	—	—	—	TR 628138	—	460
	—	—	—	—	—	GTR 628138	520
63	RNA 4911	—	—	—	—	—	265
	—	RNA 6911	—	—	—	—	475
65	—	—	—	TAF 657825	—	—	225
	—	—	—	TAF 657835	—	—	315
	RNA 49/58	—	—	—	—	—	275
68	—	—	—	TAF 688225	—	—	250
	—	—	—	TAF 688235	—	—	350
	RNA 4912	—	—	—	—	—	285
	—	RNA 6912	—	—	—	—	510

Notes⁽¹⁾ Minimum allowable value of chamfer dimension *r*
⁽²⁾ Allowable rotational speed applies to oil lubrication. For grease lubrication, a maximum of 60% of this value is allowable.
 Remarks1. The outer ring has an oil groove and an oil hole.
 2. No grease is prepacked. Perform proper lubrication.



RNA49 TAF TR

RNA69

GTR

Boundary dimensions mm				Standard mounting dimension	Basic dynamic load rating	Basic static load rating	Allowable rotational speed ⁽²⁾
<i>F_w</i>	<i>D</i>	<i>C</i>	<i>r_{s min}</i> ⁽¹⁾	<i>D_a</i> Max. mm	<i>C</i> N	<i>C₀</i> N	min ⁻¹
52	68	22	0.6	64	43 500	73 300	7 500
52	68	40	0.6	64	74 600	147 000	7 500
55	68	25	0.3	66	45 400	94 000	7 500
55	68	35	0.3	66	61 200	138 000	7 500
55	70	22	0.6	66	44 300	76 300	7 500
58	72	22	0.6	68	46 200	82 100	7 000
58	72	40	0.6	68	79 200	164 000	7 000
58	77	45	1	72	104 000	191 000	7 000
58	77	45	1	72	135 000	280 000	2 500
60	72	25	0.3	70	47 500	103 000	6 500
60	72	35	0.3	70	64 100	151 000	6 500
60	75	22	0.6	71	47 100	85 100	6 500
62	81	38	1	76	92 000	166 000	6 500
62	81	38	1	76	118 000	241 000	2 500
63	80	25	1	75	57 600	97 200	6 500
63	80	45	1	75	98 700	194 000	6 500
65	78	25	0.6	74	49 600	112 000	6 000
65	78	35	0.6	74	67 000	164 000	6 000
65	82	25	1	77	58 900	101 000	6 000
68	82	25	0.6	78	54 800	117 000	6 000
68	82	35	0.6	78	72 000	166 000	6 000
68	85	25	1	80	60 200	105 000	6 000
68	85	45	1	80	103 000	211 000	6 000

D

NA
TAFI
TRI
BRI

MACHINED TYPE NEEDLE ROLLER BEARINGS

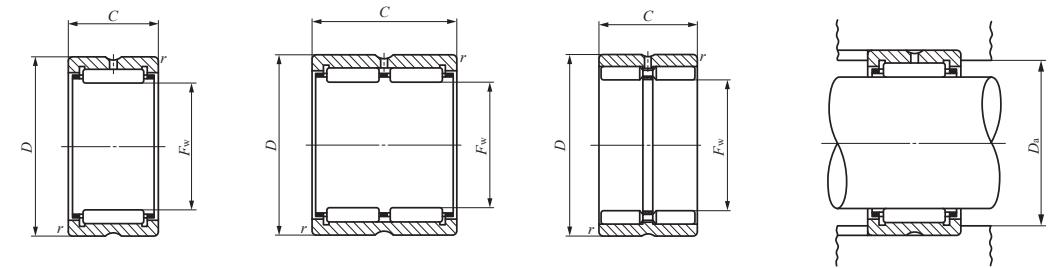
Without Inner Ring



Shaft dia. 70 – 85mm

Shaft dia. mm	Identification number						Mass (Ref.) g
	RNA 49	RNA 69	RNA 48	TAF	TR	GTR	
70	—	—	—	TAF 708525	—	—	280
	—	—	—	TAF 708535	—	—	395
	RNA 49/62	—	—	—	—	—	320
70	—	—	—	—	TR 708945	—	605
	—	—	—	—	—	GTR 708945	690
72	RNA 4913	—	—	—	—	—	325
	—	RNA 6913	—	—	—	—	585
73	—	—	—	TAF 739025	—	—	335
	—	—	—	TAF 739035	—	—	475
75	—	—	—	TAF 759225	—	—	345
	—	—	—	TAF 759235	—	—	485
	RNA 49/68	—	—	—	—	—	470
80	—	—	—	TAF 809525	—	—	315
	—	—	—	TAF 809535	—	—	445
	RNA 4914	—	—	—	—	—	495
	—	RNA 6914	—	—	—	—	910
83	—	—	—	—	TR 8310845	—	995
	—	—	—	—	—	GTR 8310845	1 090
85	—	—	—	TAF 8510525	—	—	435
	—	—	—	—	—	—	525
	—	—	—	TAF 8510535	—	—	610
	—	RNA 6915	—	—	—	—	960

Notes⁽¹⁾ Minimum allowable value of chamfer dimension *r*
⁽²⁾ Allowable rotational speed applies to oil lubrication. For grease lubrication, a maximum of 60% of this value is allowable.
 Remarks1. The outer ring has an oil groove and an oil hole.
 2. No grease is prepacked. Perform proper lubrication.



RNA49 TAF TR

RNA69

GTR

Boundary dimensions mm				Standard mounting dimension	Basic dynamic load rating	Basic static load rating	Allowable rotational speed ⁽²⁾
<i>F_w</i>	<i>D</i>	<i>C</i>	<i>r_s</i> min ⁽¹⁾	<i>D_a</i> Max. mm	<i>C</i> N	<i>C₀</i> N	min ⁻¹
70	85	25	0.6	81	55 500	120 000	5 500
70	85	35	0.6	81	73 000	171 000	5 500
70	88	25	1	83	61 500	109 000	5 500
70	89	45	1	84	114 000	228 000	5 500
70	89	45	1	84	147 000	336 000	2 000
72	90	25	1	85	62 700	113 000	5 500
72	90	45	1	85	108 000	227 000	5 500
73	90	25	1	85	61 100	127 000	5 500
73	90	35	1	85	80 400	181 000	5 500
75	92	25	1	87	62 100	131 000	5 500
75	92	35	1	87	81 700	186 000	5 500
75	95	30	1	90	79 900	147 000	5 500
80	95	25	1	90	59 400	137 000	5 000
80	95	35	1	90	78 100	195 000	5 000
80	100	30	1	95	83 200	158 000	5 000
80	100	54	1	95	134 000	311 000	5 000
83	108	45	1	103	146 000	270 000	5 000
83	108	45	1	103	190 000	396 000	1 800
85	105	25	1	100	76 300	145 000	4 500
85	105	30	1	100	86 200	169 000	4 500
85	105	35	1	100	102 000	210 000	4 500
85	105	54	1	100	138 000	331 000	4 500

MACHINED TYPE NEEDLE ROLLER BEARINGS

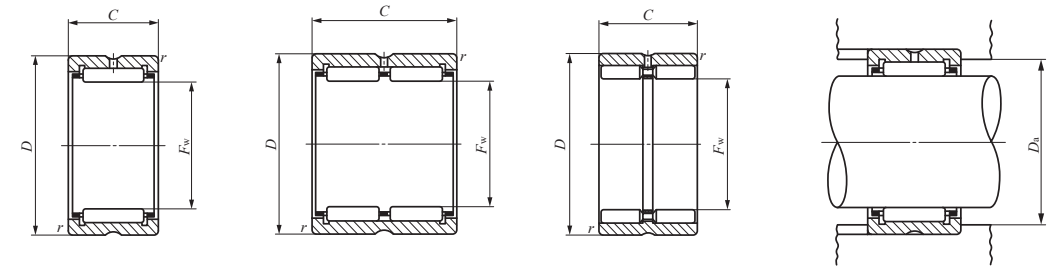
Without Inner Ring



Shaft dia. 90 – 105mm

Shaft dia. mm	Identification number						Mass (Ref.) g
	RNA 49	RNA 69	RNA 48	TAF	TR	GTR	
90	—	—	—	TAF 9011025	—	—	455
	RNA 4916	—	—	—	—	—	550
	—	—	—	TAF 9011035	—	—	640
	—	RNA 6916	—	—	—	—	1 010
93	—	—	—	—	TR 9311850	—	1 210
	—	—	—	—	—	GTR 9311850	1 340
95	—	—	—	TAF 9511526	—	—	495
	RNA 49/82	—	—	—	—	—	575
	—	—	—	TAF 9511536	—	—	690
	—	—	—	—	TR 9512045	—	1 120
	—	—	—	—	—	GTR 9512045	1 230
100	—	—	—	TAF 10012026	—	—	525
	RNA 4917	—	—	—	—	—	705
	—	—	—	TAF 10012036	—	—	725
	—	RNA 6917	—	—	—	—	1 300
	—	—	—	—	TR 10012550	—	1 290
	—	—	—	—	—	GTR 10012550	1 440
105	—	—	—	TAF 10512526	—	—	545
	RNA 4918	—	—	—	—	—	740
	—	—	—	TAF 10512536	—	—	760
	—	RNA 6918	—	—	—	—	1 360

Notes⁽¹⁾ Minimum allowable value of chamfer dimension *r*
⁽²⁾ Allowable rotational speed applies to oil lubrication. For grease lubrication, a maximum of 60% of this value is allowable.
 Remarks1. The outer ring has an oil groove and an oil hole.
 2. No grease is prepacked. Perform proper lubrication.



RNA49 TAF TR

RNA69

GTR

Boundary dimensions mm				Standard mounting dimension	Basic dynamic load rating	Basic static load rating	Allowable rotational speed ⁽²⁾ min ⁻¹
<i>F_w</i>	<i>D</i>	<i>C</i>	<i>r_s</i> min ⁽¹⁾	<i>D_a</i> Max. mm	<i>C</i> N	<i>C₀</i> N	
90	110	25	1	105	77 300	150 000	4 500
90	110	30	1	105	87 300	175 000	4 500
90	110	35	1	105	103 000	217 000	4 500
90	110	54	1	105	143 000	351 000	4 500
93	118	50	1	113	165 000	329 000	4 500
93	118	50	1	113	224 000	509 000	1 600
95	115	26	1	110	79 700	159 000	4 000
95	115	30	1	110	90 000	186 000	4 000
95	115	36	1	110	106 000	231 000	4 000
95	120	45	1.5	112	155 000	305 000	4 000
95	120	45	1.5	112	204 000	455 000	1 600
100	120	26	1	115	82 400	168 000	4 000
100	120	35	1.1	113.5	110 000	244 000	4 000
100	120	36	1	115	110 000	244 000	4 000
100	120	63	1.1	113.5	173 000	467 000	4 000
100	125	50	1.5	117	172 000	355 000	4 000
100	125	50	1.5	117	234 000	549 000	1 500
105	125	26	1	120	84 700	178 000	4 000
105	125	35	1.1	118.5	113 000	258 000	4 000
105	125	36	1	120	113 000	258 000	4 000
105	125	63	1.1	118.5	178 000	490 000	4 000

D
NA
TAFI
TRI
BRI

MACHINED TYPE NEEDLE ROLLER BEARINGS

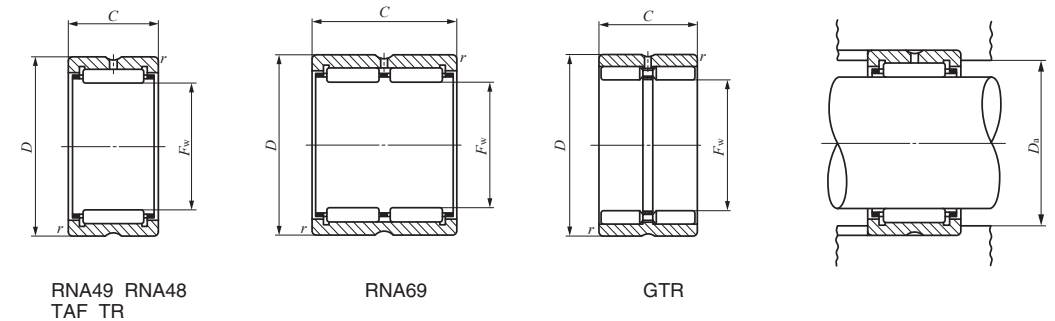
Without Inner Ring



Shaft dia. 110 – 170mm

Shaft dia. mm	Identification number						Mass (Ref.) g
	RNA 49	RNA 69	RNA 48	TAF	TR	GTR	
110	—	—	—	TAF 11013030	—	—	660
	RNA 4919	—	—	—	—	—	770
	—	—	—	TAF 11013040	—	—	880
	—	RNA 6919	—	—	—	—	1 420
	—	—	—	—	TR 11013550	—	1 400
	—	—	—	—	—	GTR 11013550	1 560
115	RNA 4920	—	—	—	—	—	1 190
	—	—	—	—	TR 11515350	—	2 350
	—	—	—	—	—	GTR 11515350	2 600
120	—	—	RNA 4822	—	—	—	790
125	RNA 4922	—	—	—	—	—	1 280
130	—	—	RNA 4824	—	—	—	850
135	RNA 4924	—	—	—	—	—	1 930
140	—	—	—	—	TR 14017860	—	3 320
	—	—	—	—	—	GTR 14017860	3 730
145	—	—	RNA 4826	—	—	—	1 100
150	RNA 4926	—	—	—	—	—	2 360
	—	—	—	—	TR 15018860	—	3 540
	—	—	—	—	—	GTR 15018860	3 970
155	—	—	RNA 4828	—	—	—	1 170
160	RNA 4928	—	—	—	—	—	2 500
165	—	—	RNA 4830	—	—	—	1 750
170	RNA 4930	—	—	—	—	—	4 090

Notes⁽¹⁾ Minimum allowable value of chamfer dimension *r*
⁽²⁾ Allowable rotational speed applies to oil lubrication. For grease lubrication, a maximum of 60% of this value is allowable.
 Remarks1. The outer ring has an oil groove and an oil hole.
 2. No grease is prepacked. Perform proper lubrication.



Boundary dimensions mm				Standard mounting dimension	Basic dynamic load rating	Basic static load rating	Allowable rotational speed ⁽²⁾ min ⁻¹
<i>F_w</i>	<i>D</i>	<i>C</i>	<i>r_{s min}</i> ⁽¹⁾	<i>D_a</i> Max. mm	<i>C</i> N	<i>C₀</i> N	
110	130	30	1	125	106 000	240 000	3 500
110	130	35	1.1	123.5	116 000	271 000	3 500
110	130	40	1	125	134 000	324 000	3 500
110	130	63	1.1	123.5	182 000	514 000	3 500
110	135	50	1.5	127	183 000	395 000	3 500
110	135	50	1.5	127	245 000	603 000	1 400
115	140	40	1.1	133.5	145 000	329 000	3 500
115	153	50	1.5	145	233 000	414 000	3 500
115	153	50	1.5	145	315 000	614 000	1 300
120	140	30	1	135	93 200	239 000	3 500
125	150	40	1.1	143.5	152 000	357 000	3 000
130	150	30	1	145	96 900	259 000	3 000
135	165	45	1.1	158.5	187 000	435 000	3 000
140	178	60	1.5	170	307 000	625 000	3 000
140	178	60	1.5	170	409 000	923 000	1 100
145	165	35	1.1	158.5	116 000	340 000	3 000
150	180	50	1.5	172	215 000	540 000	2 500
150	188	60	1.5	180	320 000	675 000	2 500
150	188	60	1.5	180	423 000	989 000	1 000
155	175	35	1.1	168.5	120 000	363 000	2 500
160	190	50	1.5	182	224 000	580 000	2 500
165	190	40	1.1	183.5	168 000	446 000	2 500
170	210	60	2	201	324 000	712 000	2 500

D
NA
TAFI
TRI
BRI

MACHINED TYPE NEEDLE ROLLER BEARINGS

Without Inner Ring



Shaft dia. 175 – 350mm

Shaft dia. mm	Identification number						Mass (Ref.) g
	RNA 49	RNA 69	RNA 48	TAF	TR	GTR	
175	—	—	RNA 4832	—	—	—	1 850
180	RNA 4932	—	—	—	—	—	4 310
185	—	—	RNA 4834	—	—	—	2 700
190	RNA 4934	—	—	—	—	—	4 530
195	—	—	RNA 4836	—	—	—	2 840
205	RNA 4936	—	—	—	—	—	6 250
210	—	—	RNA 4838	—	—	—	3 380
215	RNA 4938	—	—	—	—	—	6 500
220	—	—	RNA 4840	—	—	—	3 520
225	RNA 4940	—	—	—	—	—	10 400
240	—	—	RNA 4844	—	—	—	3 820
245	RNA 4944	—	—	—	—	—	11 200
265	— RNA 4948	—	RNA 4848 —	—	—	—	5 670 12 000
285	—	—	RNA 4852	—	—	—	6 070
290	RNA 4952	—	—	—	—	—	21 200
305	—	—	RNA 4856	—	—	—	9 750
310	RNA 4956	—	—	—	—	—	22 500
330	—	—	RNA 4860	—	—	—	13 200
340	RNA 4960	—	—	—	—	—	33 400
350	—	—	RNA 4864	—	—	—	14 100

Notes⁽¹⁾ Minimum allowable value of chamfer dimension *r*
⁽²⁾ Allowable rotational speed applies to oil lubrication. For grease lubrication, a maximum of 60% of this value is allowable.
 Remarks1. The outer ring has an oil groove and an oil hole.
 2. No grease is prepacked. Perform proper lubrication.



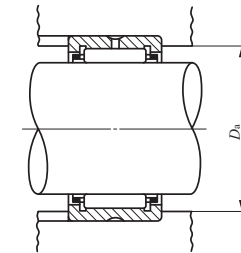
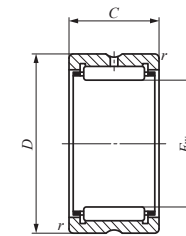
RNA49 RNA48

Boundary dimensions mm				Standard mounting dimension	Basic dynamic load rating	Basic static load rating	Allowable rotational speed ⁽²⁾
F_w	D	C	$r_{s \min}^{(1)}$	D_a Max. mm	C N	C_0 N	min ⁻¹
175	200	40	1.1	193.5	173 000	474 000	2 500
180	220	60	2	211	337 000	761 000	1 900
185	215	45	1.1	208.5	211 000	567 000	1 900
190	230	60	2	221	347 000	810 000	1 900
195	225	45	1.1	218.5	218 000	602 000	1 900
205	250	69	2	241	434 000	989 000	1 900
210	240	50	1.5	232	249 000	726 000	1 800
215	260	69	2	251	440 000	1 020 000	1 700
220	250	50	1.5	242	255 000	766 000	1 600
225	280	80	2.1	269	518 000	1 120 000	1 600
240	270	50	1.5	262	266 000	833 000	1 500
245	300	80	2.1	289	536 000	1 200 000	1 400
265	300	60	2	291	345 000	1 150 000	1 300
265	320	80	2.1	309	565 000	1 320 000	1 300
285	320	60	2	311	354 000	1 220 000	1 100
290	360	100	2.1	349	847 000	1 900 000	1 100
305	350	69	2	341	486 000	1 550 000	950
310	380	100	2.1	369	877 000	2 040 000	950
330	380	80	2.1	369	610 000	1 900 000	900
340	420	118	3	407	1 130 000	2 650 000	850
350	400	80	2.1	389	635 000	2 040 000	750

D
NA
TAFI
TRI
BRI

MACHINED TYPE NEEDLE ROLLER BEARINGS

Without Inner Ring



RNA49 RNA48

Shaft dia. 360 – 490mm

Shaft dia. mm	Identification number						Mass (Ref.) g
	RNA 49	RNA 69	RNA 48	TAF	TR	GTR	
360	RNA 4964	—	—	—	—	—	35 200
370	—	—	RNA 4868	—	—	—	14 800
380	RNA 4968	—	—	—	—	—	37 000
390	—	—	RNA 4872	—	—	—	15 600
400	RNA 4972	—	—	—	—	—	38 700
415	—	—	RNA 4876	—	—	—	27 900
430	RNA 4976	—	—	—	—	—	56 400
450	RNA 4980	—	—	—	—	—	58 800
470	RNA 4984	—	—	—	—	—	61 200
490	RNA 4988	—	—	—	—	—	86 900

Notes⁽¹⁾ Minimum allowable value of chamfer dimension *r*
⁽²⁾ Allowable rotational speed applies to oil lubrication. For grease lubrication, a maximum of 60% of this value is allowable.
 Remarks1. The outer ring has an oil groove and an oil hole.
 2. No grease is prepacked. Perform proper lubrication.

Boundary dimensions mm				Standard mounting dimension	Basic dynamic load rating	Basic static load rating	Allowable rotational speed ⁽²⁾ min ⁻¹
<i>F_w</i>	<i>D</i>	<i>C</i>	<i>r_{s min}</i> ⁽¹⁾	<i>D_a</i> Max. mm	<i>C</i> N	<i>C₀</i> N	
360	440	118	3	427	1 170 000	2 830 000	750
370	420	80	2.1	409	651 000	2 140 000	700
380	460	118	3	447	1 220 000	3 020 000	700
390	440	80	2.1	429	680 000	2 320 000	650
400	480	118	3	467	1 260 000	3 200 000	600
415	480	100	2.1	469	951 000	2 860 000	600
430	520	140	4	504	1 540 000	4 030 000	500
450	540	140	4	524	1 590 000	4 270 000	500
470	560	140	4	544	1 640 000	4 510 000	500
490	600	160	4	584	1 910 000	5 140 000	400

D

NA
TAFI
TRI
BRI

MACHINED TYPE NEEDLE ROLLER BEARINGS

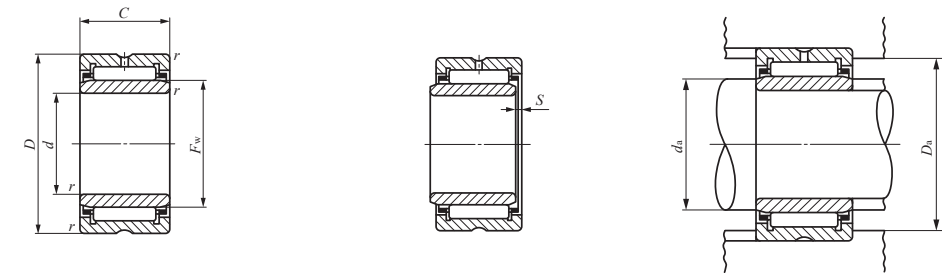
With Inner Ring



Shaft dia. 5 – 12mm

Shaft dia. mm	Identification number						Mass (Ref.) g	d
	NA 49	NA 69	NA 48	TAFI	TRI	GTRI		
5	NA 495	—	—	—	—	—	7.3	5
	—	—	—	TAFI 51512	—	—	11.9	5
	—	—	—	TAFI 51516	—	—	16.7	5
6	NA 496	—	—	—	—	—	9.1	6
	—	—	—	TAFI 61612	—	—	13	6
	—	—	—	TAFI 61616	—	—	17.5	6
7	NA 497	—	—	—	—	—	11.2	7
	—	—	—	TAFI 71712	—	—	14.3	7
	—	—	—	TAFI 71716	—	—	19.2	7
8	NA 498	—	—	—	—	—	15	8
9	—	—	—	TAFI 91912	—	—	16.7	9
	—	—	—	TAFI 91916	—	—	22.5	9
	NA 499	—	—	—	—	—	16.7	9
10	NA 4900	—	—	—	—	—	24	10
	—	—	—	TAFI 102216	—	—	30	10
	—	—	—	TAFI 102220	—	—	38	10
12	NA 4901	—	—	—	—	—	26.5	12
	—	—	—	TAFI 122416	—	—	33.5	12
	—	—	—	TAFI 122420	—	—	42.5	12
	—	NA 6901	—	—	—	—	44.5	12

Notes⁽¹⁾ Minimum allowable value of chamfer dimension *r*
⁽²⁾ Allowable axial shift amount of inner ring to outer ring
⁽³⁾ Allowable rotational speed applies to oil lubrication. For grease lubrication, a maximum of 60% of this value is allowable.
 Remarks1. TAFI series with a bore diameter *d* of 22 mm or less have no oil hole. In others, the outer ring has an oil groove and an oil hole.
 2. No grease is prepacked. Perform proper lubrication.

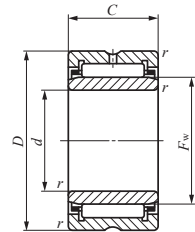


NA49 TAFI
NA69 (*d* ≤ 30)

Boundary dimensions mm						Standard mounting dimensions mm			Basic dynamic load rating <i>C</i> N	Basic static load rating <i>C</i> ₀ N	Allowable rotational speed ⁽³⁾ min ⁻¹	Assembled inner ring
<i>D</i>	<i>C</i>	<i>B</i>	<i>r</i> _{s min} ⁽¹⁾	<i>F</i> _w ⁽²⁾	<i>S</i> ⁽²⁾	Min. <i>d</i> _a	Max. <i>d</i> _a	<i>D</i> _a Max.				
13	10	—	0.15	7	0.5	6.2	6.7	11.8	2 960	2 690	60 000	LRT 5710
15	12	—	0.2	8	0.5	6.6	7.7	13.4	5 060	4 690	50 000	LRT 5812
15	16	—	0.2	8	0.5	6.6	7.7	13.4	7 080	7 220	50 000	LRT 5816
15	10	—	0.15	8	0.5	7.2	7.7	13.8	3 960	3 420	50 000	LRT 6810
16	12	—	0.2	9	0.5	7.6	8.7	14.4	5 490	5 330	45 000	LRT 6912
16	16	—	0.2	9	0.5	7.6	8.7	14.4	7 680	8 210	45 000	LRT 6916
17	10	—	0.15	9	0.5	8.2	8.7	15.8	4 530	3 650	45 000	LRT 7910
17	12	—	0.2	10	0.5	8.6	9.7	15.4	5 880	5 970	40 000	LRT 71012
17	16	—	0.2	10	0.5	8.6	9.7	15.4	8 230	9 190	40 000	LRT 71016
19	11	—	0.2	10	0.5	9.6	9.9	17.4	6 180	5 030	40 000	LRT 81011
19	12	—	0.3	12	0.5	11	11.5	17	6 610	7 260	35 000	LRT 91212
19	16	—	0.3	12	0.5	11	11.5	17	9 250	11 200	35 000	LRT 91216
20	11	—	0.3	12	0.5	11	11.5	18	6 600	6 310	35 000	LRT 91211
22	13	—	0.3	14	0.5	12	13	20	9 230	10 100	30 000	LRT 101413
22	16	—	0.3	14	0.5	12	13	20	11 700	13 700	30 000	LRT 101416
22	20	—	0.3	14	0.5	12	13	20	14 800	18 600	30 000	LRT 101420
24	13	—	0.3	16	0.5	14	15	22	9 660	11 100	25 000	LRT 121613
24	16	—	0.3	16	0.5	14	15	22	12 300	15 100	25 000	LRT 121616
24	20	—	0.3	16	0.5	14	15	22	15 500	20 400	25 000	LRT 121620
24	22	—	0.3	16	0.5	14	15	22	17 100	23 000	25 000	LRT 121622

MACHINED TYPE NEEDLE ROLLER BEARINGS

With Inner Ring

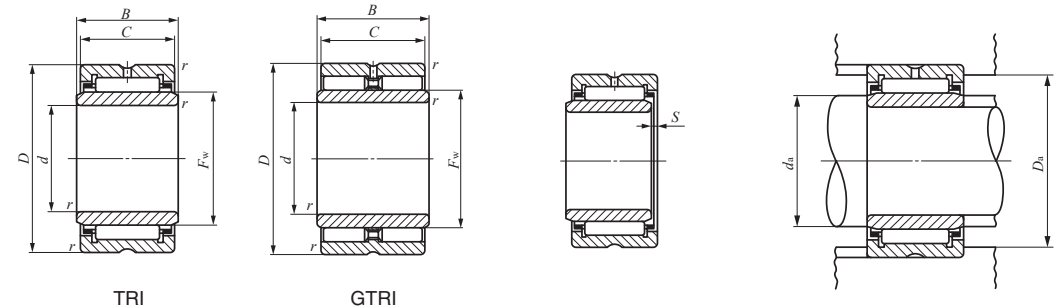


NA49 TAFI
NA69 ($d \leq 30$)

Shaft dia. 15 – 22mm

Shaft dia. mm	Identification number						Mass (Ref.) g	d
	NA 49	NA 69	NA 48	TAFI	TRI	GTRI		
15	—	—	—	TAFI 152716	—	—	39.5	15
	—	—	—	TAFI 152720	—	—	50	15
	NA 4902	—	—	—	—	—	35	15
	—	NA 6902	—	—	—	—	61	15
	—	—	—	—	TRI 153320	—	81	15
17	—	—	—	TAFI 172916	—	—	43.5	17
	—	—	—	TAFI 172920	—	—	54	17
	NA 4903	—	—	—	—	—	39	17
	—	NA 6903	—	—	—	—	67	17
	—	—	—	—	TRI 173425	—	104	17
20	—	—	—	TAFI 203216	—	—	48.5	20
	—	—	—	TAFI 203220	—	—	61	20
	NA 4904	—	—	—	—	—	78.5	20
	—	NA 6904	—	—	—	—	136	20
	—	—	—	—	TRI 203820	—	99	20
22	—	—	—	TAFI 223416	—	—	52	22
	—	—	—	TAFI 223420	—	—	67.5	22
	NA 49/22	—	—	—	—	—	87	22
	—	NA 69/22	—	—	—	—	152	22
	—	—	—	—	TRI 203825	—	124	20
—	—	—	—	—	GTRI 203820	110	20	
—	—	—	—	—	GTRI 203825	138	20	

Notes⁽¹⁾ Minimum allowable value of chamfer dimension r
⁽²⁾ Allowable axial shift amount of inner ring to outer ring
⁽³⁾ Allowable rotational speed applies to oil lubrication. For grease lubrication, a maximum of 60% of this value is allowable.
 Remarks1. TAFI series with a bore diameter d of 22 mm or less have no oil hole. In others, the outer ring has an oil groove and an oil hole.
 2. No grease is prepacked. Perform proper lubrication.

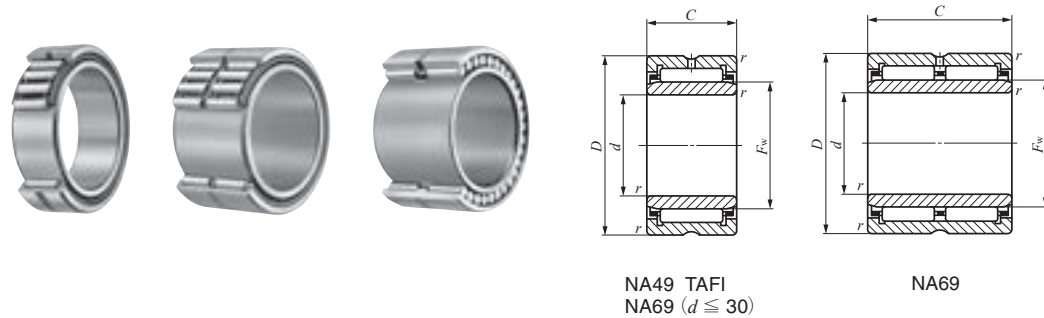


Boundary dimensions mm						Standard mounting dimensions mm			Basic dynamic load rating	Basic static load rating	Allowable rotational speed ⁽³⁾	Assembled inner ring
D	C	B	$r_{s\ min}^{(1)}$	$F_w^{(2)}$	$S^{(2)}$	Min.	d_a Max.	D_a Max.	C N	C_0 N	min ⁻¹	
27	16	—	0.3	19	0.5	17	18	25	14 000	18 700	20 000	LRT 151916
27	20	—	0.3	19	0.5	17	18	25	17 700	25 300	20 000	LRT 151920
28	13	—	0.3	20	0.3	17	19	26	10 900	13 800	20 000	LRT 152013
28	23	—	0.3	20	0.3	17	19	26	19 300	28 800	20 000	LRT 152023
33	20	20.5	0.3	20	0.3	17	19	31	24 300	26 500	20 000	LRT 152020
33	20	20.5	0.3	20	—	17	19	31	29 200	37 200	7 500	LRTZ 152020
29	16	—	0.3	21	0.5	19	20	27	14 400	20 000	19 000	LRT 172116
29	20	—	0.3	21	0.5	19	20	27	18 200	27 100	19 000	LRT 172120
30	13	—	0.3	22	0.3	19	21	28	11 700	15 600	18 000	LRT 172213
30	23	—	0.3	22	0.3	19	21	28	20 800	32 500	18 000	LRT 172223
34	25	25.5	0.3	22	0.5	19	21	32	29 100	36 800	18 000	LRT 172225
34	25	25.5	0.3	22	—	19	21	32	37 900	57 800	7 000	LRTZ 172225
32	16	—	0.3	24	0.5	22	23	30	15 300	22 500	17 000	LRT 202416
32	20	—	0.3	24	0.5	22	23	30	19 400	30 500	17 000	LRT 202420
37	17	—	0.3	25	0.5	22	24	35	21 000	25 000	16 000	LRT 202517
37	30	—	0.3	25	0.5	22	24	35	35 400	48 900	16 000	LRT 202530
38	20	20.5	0.3	25	0.3	22	24	36	28 900	35 000	16 000	LRT 202520
38	25	25.5	0.3	25	0.5	22	24	36	34 800	44 400	16 000	LRT 202525
38	20	20.5	0.3	25	—	22	24	36	33 300	46 500	6 000	LRTZ 202520
38	25	25.5	0.3	25	—	22	24	36	42 400	63 700	6 000	LRTZ 202525
34	16	—	0.3	26	0.5	24	25	32	16 300	24 900	15 000	LRT 222616
34	20	—	0.3	26	0.5	24	25	32	20 600	33 800	15 000	LRT 222620
39	17	—	0.3	28	1	24	27	37	21 400	28 900	14 000	LRT 222817
39	30	—	0.3	28	0.5	24	27	37	36 300	56 900	14 000	LRT 222830

D
NA
TAFI
TRI
BRI

MACHINED TYPE NEEDLE ROLLER BEARINGS

With Inner Ring



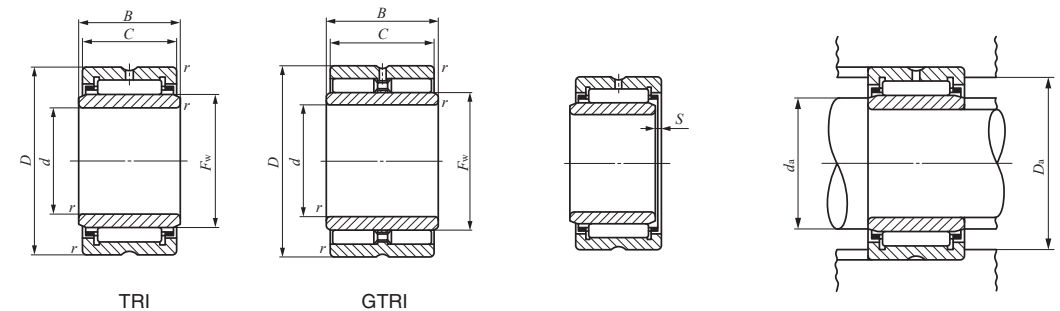
NA49 TAFI
NA69 ($d \leq 30$)

NA69

Shaft dia. 25 – 32mm

Shaft dia. mm	Identification number						Mass (Ref.) g	d
	NA 49	NA 69	NA 48	TAFI	TRI	GTRI		
25	—	—	—	TAFI 253820	—	—	82	25
	—	—	—	TAFI 253830	—	—	123	25
	NA 4905	—	—	—	—	—	92.5	25
	—	NA 6905	—	—	—	—	160	25
	—	—	—	—	TRI 254425	—	157	25
28	—	—	—	TAFI 284220	—	—	96.5	28
	—	—	—	TAFI 284230	—	—	145	28
	NA 49/28	—	—	—	—	—	101	28
	—	NA 69/28	—	—	—	—	176	28
	—	—	—	—	—	GTRI 284530	196	28
30	—	—	—	TAFI 304520	—	—	112	30
	—	—	—	TAFI 304530	—	—	171	30
	NA 4906	—	—	—	—	—	106	30
	—	NA 6906	—	—	—	—	184	30
	—	—	—	—	TRI 304830	—	199	30
32	—	—	—	TAFI 324720	—	—	121	32
	—	—	—	TAFI 324730	—	—	180	32
	NA 49/32	—	—	—	—	—	165	32
	—	—	—	—	TRI 325230	—	245	32
	—	NA 69/32	—	—	—	GTRI 325230	295	32
—	—	—	—	—	—	270	32	

Notes⁽¹⁾ Minimum allowable value of chamfer dimension r
⁽²⁾ Allowable axial shift amount of inner ring to outer ring
⁽³⁾ Allowable rotational speed applies to oil lubrication. For grease lubrication, a maximum of 60% of this value is allowable.
 Remarks1. The outer ring has an oil groove and an oil hole.
 2. No grease is prepacked. Perform proper lubrication.



TRI

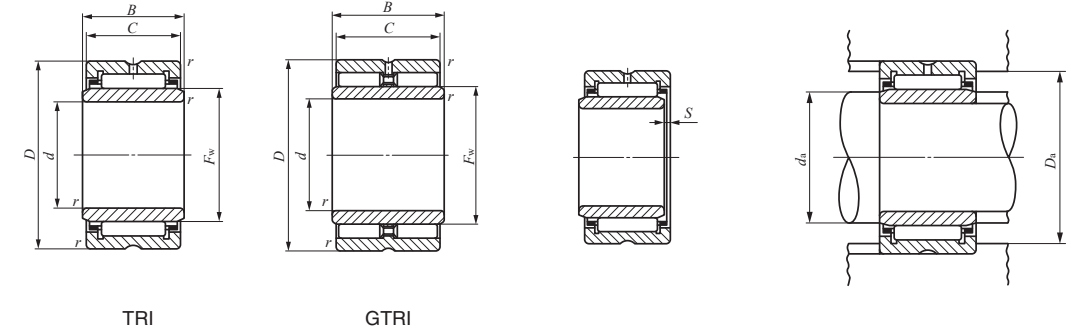
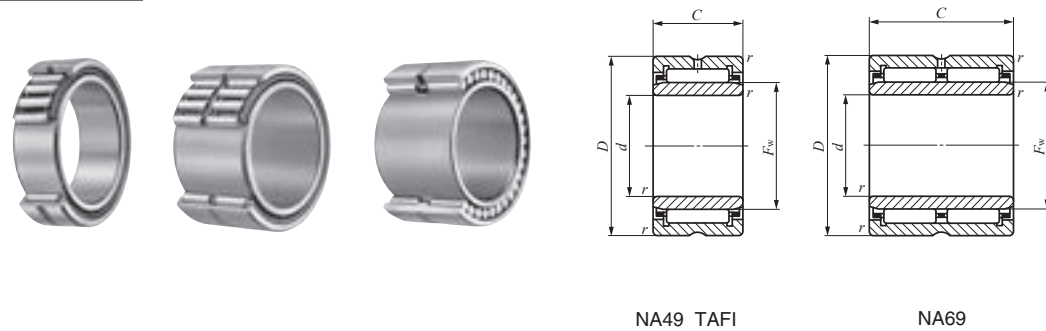
GTRI

Boundary dimensions mm						Standard mounting dimensions mm			Basic dynamic load rating C N	Basic static load rating C_0 N	Allowable rotational speed ⁽³⁾ min ⁻¹	Assembled inner ring
D	C	B	$r_{s\ min}^{(1)}$	$F_w^{(2)}$	$S^{(2)}$	Min.	d_a Max.	D_a Max.				
38	20	—	0.3	29	0.5	27	28	36	21 600	37 200	14 000	LRT 252920
38	30	—	0.3	29	1	27	28	36	30 900	59 100	14 000	LRT 252930
42	17	—	0.3	30	0.5	27	29	40	23 700	30 700	13 000	LRT 253017
42	30	—	0.3	30	0.5	27	29	40	42 100	64 300	13 000	LRT 253030
44	25	25.5	0.3	30	0.5	27	29	42	37 900	52 100	13 000	LRT 253025
44	25	25.5	0.3	30	—	27	29	42	47 000	76 500	5 000	LRTZ 253025
42	20	—	0.3	32	0.5	30	31	40	25 700	42 200	12 000	LRT 283220
42	30	—	0.3	32	1	30	31	40	36 800	67 200	12 000	LRT 283230
45	17	—	0.3	32	1	30	31	43	24 500	32 700	12 000	LRT 283217
45	30	—	0.3	32	1	30	31	43	41 800	64 800	12 000	LRT 283230
45	30	30.5	0.3	32	—	30	31	43	58 000	101 000	4 500	LRTZ 283230
45	20	—	0.3	35	0.3	32	34	43	26 900	46 200	11 000	LRT 303520
45	30	—	0.3	35	0.5	32	34	43	38 600	73 600	11 000	LRT 303530
47	17	—	0.3	35	0.5	32	34	45	25 200	34 700	11 000	LRT 303517
47	30	—	0.3	35	0.5	32	34	45	43 000	69 000	11 000	LRT 303530
48	30	30.5	0.3	35	1	32	34	46	47 400	72 300	11 000	LRT 303530-1
48	30	30.5	0.3	35	—	32	34	46	61 100	110 000	4 500	LRTZ 303530
47	20	—	0.3	37	0.3	34	36	45	28 200	50 100	11 000	LRT 323720
47	30	—	0.3	37	0.5	34	36	45	40 500	79 800	11 000	LRT 323730
52	20	—	0.6	40	0.5	36	39	48	31 200	47 800	10 000	LRT 324020
52	30	30.5	0.6	38	0.5	36	37	48	50 800	81 100	11 000	LRT 323830
52	36	—	0.6	40	0.3	36	39	48	53 500	95 700	10 000	LRT 324036
52	30	30.5	0.6	38	—	36	37	48	64 200	121 000	4 000	LRTZ 323830

D
NA
TAFI
TRI
BRI

MACHINED TYPE NEEDLE ROLLER BEARINGS

With Inner Ring



Shaft dia. 35 – 45mm

Shaft dia. mm	Identification number						Mass (Ref.) g	d
	NA 49	NA 69	NA 48	TAFI	TRI	GTRI		
35	—	—	—	TAFI 355020	—	—	129	35
	—	—	—	TAFI 355030	—	—	192	35
	NA 4907	—	—	—	—	—	178	35
	—	NA 6907	—	—	—	—	320	35
	—	—	—	—	TRI 355630	—	280	35
	—	—	—	—	—	GTRI 355520 GTRI 355630	191 310	35 35
38	—	—	—	TAFI 385320	—	—	136	38
	—	—	—	TAFI 385330	—	—	205	38
40	—	—	—	TAFI 405520	—	—	143	40
	—	—	—	TAFI 405530	—	—	215	40
	—	—	—	—	TRI 405930	—	270	40
	NA 4908	—	—	—	—	—	245	40
	—	NA 6908	—	—	—	—	440	40
	—	—	—	—	—	GTRI 405930	300	40
42	—	—	—	TAFI 425720	—	—	149	42
	—	—	—	TAFI 425730	—	—	225	42
	—	—	—	—	TRI 426230	—	305	42
	—	—	—	—	—	GTRI 426230	340	42
45	—	—	—	TAFI 456225	—	—	230	45
	—	—	—	TAFI 456235	—	—	320	45
	—	—	—	—	TRI 456430	—	300	45
	NA 4909	—	—	—	—	—	285	45
	—	NA 6909	—	—	—	—	520	45
	—	—	—	—	—	GTRI 456430	335	45

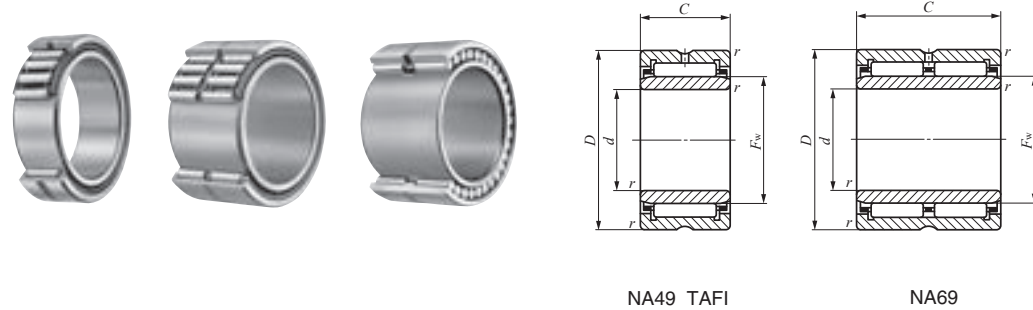
Notes⁽¹⁾ Minimum allowable value of chamfer dimension *r*
⁽²⁾ Allowable axial shift amount of inner ring to outer ring
⁽³⁾ Allowable rotational speed applies to oil lubrication. For grease lubrication, a maximum of 60% of this value is allowable.
 Remarks1. The outer ring has an oil groove and an oil hole.
 2. No grease is prepacked. Perform proper lubrication.

Boundary dimensions mm						Standard mounting dimensions mm			Basic dynamic load rating <i>C</i> N	Basic static load rating <i>C</i> ₀ N	Allowable rotational speed ⁽³⁾ min ⁻¹	Assembled inner ring
<i>D</i>	<i>C</i>	<i>B</i>	<i>r</i> _{s min} ⁽¹⁾	<i>F</i> _w ⁽²⁾	<i>S</i> ⁽²⁾	Min. <i>d</i> _a	Max. <i>d</i> _a	<i>D</i> _a Max.				
50	20	—	0.3	40	0.3	37	39	48	29 400	54 100	10 000	LRT 354020
50	30	—	0.3	40	0.5	37	39	48	42 300	86 200	10 000	LRT 354030
55	20	—	0.6	42	0.5	39	41	51	32 000	50 100	9 500	LRT 354220
55	36	—	0.6	42	0.3	39	41	51	54 900	100 000	9 500	LRT 354236
56	30	30.5	0.6	42	0.5	39	41	52	53 800	90 100	9 500	LRT 354230
55	20	20.5	0.6	40	—	39	39.5	51	44 300	73 600	3 500	LRTZ 354020
56	30	30.5	0.6	42	—	39	41	52	67 500	133 000	3 500	LRTZ 354230
53	20	—	0.3	43	0.3	40	42	51	30 500	58 200	9 500	LRT 384320
53	30	—	0.3	43	0.5	40	42	51	43 800	92 600	9 500	LRT 384330
55	20	—	0.3	45	0.3	42	44	53	31 000	60 200	9 000	LRT 404520
55	30	—	0.3	45	0.5	42	44	53	44 600	95 800	9 000	LRT 404530
59	30	30.5	0.6	45	1	44	44.5	55	55 100	94 800	9 000	LRT 404530-1
62	22	—	0.6	48	0.5	44	47	58	41 600	67 400	8 500	LRT 404822
62	40	—	0.6	48	0.3	44	47	58	71 300	135 000	8 500	LRT 404840
59	30	30.5	0.6	45	—	44	44.5	55	70 300	142 000	3 500	LRTZ 404530
57	20	—	0.3	47	0.3	44	46	55	31 500	62 200	8 500	LRT 424720
57	30	—	0.3	47	0.5	44	46	55	45 200	99 100	8 500	LRT 424730
62	30	30.5	0.6	48	0.5	46	47	58	56 300	99 500	8 500	LRT 424830
62	30	30.5	0.6	48	—	46	47	58	72 700	154 000	3 000	LRTZ 424830
62	25	—	0.3	50	0.5	47	49	60	43 000	85 300	8 000	LRT 455025
62	35	—	0.3	50	1	47	49	60	58 000	125 000	8 000	LRT 455035
64	30	30.5	0.6	50	1	49	49.5	60	57 700	104 000	8 000	LRT 455030
68	22	—	0.6	52	0.5	49	51	64	43 500	73 300	7 500	LRT 455222
68	40	—	0.6	52	0.3	49	51	64	74 600	147 000	7 500	LRT 455240
64	30	30.5	0.6	50	—	49	49.5	60	74 600	158 000	3 000	LRTZ 455030

D
NA
TAFI
TRI
BRI

MACHINED TYPE NEEDLE ROLLER BEARINGS

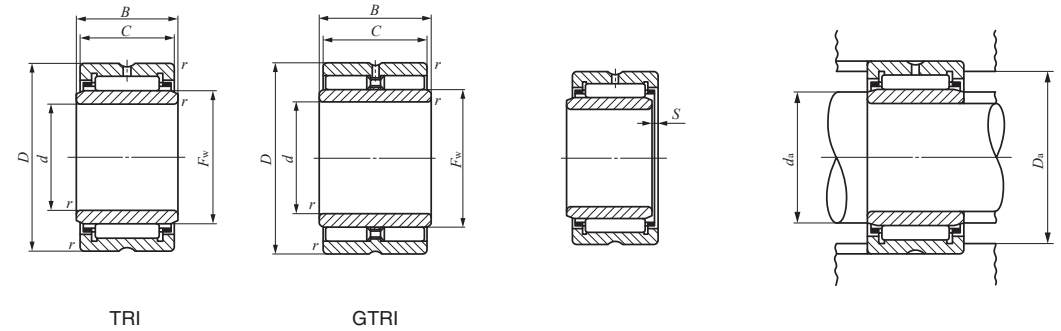
With Inner Ring



Shaft dia. 50 – 70mm

Shaft dia. mm	Identification number						Mass (Ref.) g	d
	NA 49	NA 69	NA 48	TAFI	TRI	GTRI		
50	—	—	—	TAFI 506825	—	—	270	50
	—	—	—	TAFI 506835	—	—	365	50
	NA 4910	—	—	—	—	—	295	50
	—	NA 6910	—	—	—	—	530	50
	—	—	—	—	TRI 507745	—	755	50
55	—	—	—	TAFI 557225	—	—	275	55
	—	—	—	TAFI 557235	—	—	380	55
	NA 4911	—	—	—	—	—	410	55
	—	NA 6911	—	—	—	—	730	55
	—	—	—	—	TRI 558138	—	650	55
60	—	—	—	TAFI 608225	—	—	395	60
	—	—	—	TAFI 608235	—	—	560	60
	NA 4912	—	—	—	—	—	440	60
	—	NA 6912	—	—	—	—	785	60
	—	—	—	—	TRI 608945	—	960	60
65	—	—	—	—	—	—	1 050	60
	NA 4913	—	—	—	—	—	470	65
	—	NA 6913	—	TAFI 659035	—	—	710	65
70	—	—	—	—	—	—	840	65
	—	—	—	TAFI 709525	—	—	540	70
	NA 4914	—	—	TAFI 709535	—	—	755	70
	—	—	—	—	—	—	765	70
	—	NA 6914	—	—	—	—	1 400	70

Notes⁽¹⁾ Minimum allowable value of chamfer dimension *r*
⁽²⁾ Allowable axial shift amount of inner ring to outer ring
⁽³⁾ Allowable rotational speed applies to oil lubrication. For grease lubrication, a maximum of 60% of this value is allowable.
 Remarks1. The outer ring has an oil groove and an oil hole.
 2. No grease is prepacked. Perform proper lubrication.

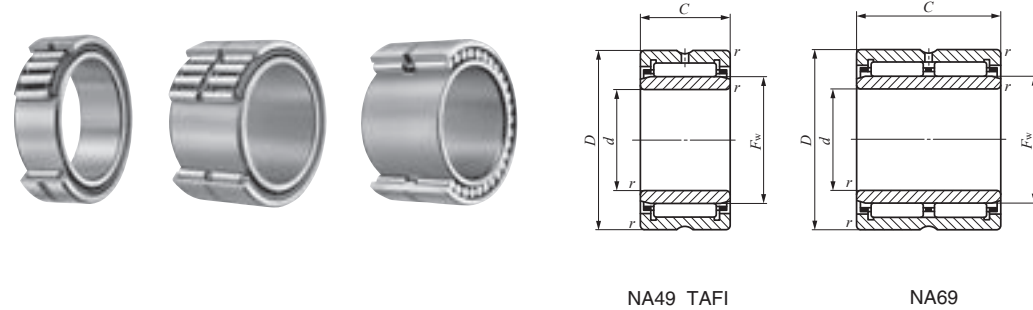


Boundary dimensions mm						Standard mounting dimensions mm			Basic dynamic load rating C N	Basic static load rating C ₀ N	Allowable rotational speed ⁽³⁾ min ⁻¹	Assembled inner ring
D	C	B	r _{s min} ⁽¹⁾	F _w ⁽²⁾	S ⁽²⁾	Min. d _a	Max. d _a	D _a Max.				
68	25	—	0.3	55	0.5	52	54	66	45 400	94 000	7 500	LRT 505525
68	35	—	0.3	55	1	52	54	66	61 200	138 000	7 500	LRT 505535
72	22	—	0.6	58	0.5	54	57	68	46 200	82 100	7 000	LRT 505822
72	40	—	0.6	58	0.3	54	57	68	79 200	164 000	7 000	LRT 505840
77	45	45.5	1	58	2	55	57	72	104 000	191 000	7 000	LRT 505845
77	45	45.5	1	58	—	55	57	72	135 000	280 000	2 500	LRTZ 505845
72	25	—	0.3	60	0.5	57	59	70	47 500	103 000	6 500	LRT 556025
72	35	—	0.3	60	1	57	59	70	64 100	151 000	6 500	LRT 556035
80	25	—	1	63	1	60	61	75	57 600	97 200	6 500	LRT 556325
80	45	—	1	63	0.5	60	61	75	98 700	194 000	6 500	LRT 556345
81	38	38.5	1	62	1.5	60	60.5	76	92 000	166 000	6 500	LRT 556238
81	38	38.5	1	62	—	60	60.5	76	118 000	241 000	2 500	LRTZ 556238
82	25	—	0.6	68	0.3	64	66	78	54 800	117 000	6 000	LRT 606825
82	35	—	0.6	68	1	64	66	78	72 000	166 000	6 000	LRT 606835
85	25	—	1	68	1	65	66	80	60 200	105 000	6 000	LRT 606825-1
85	45	—	1	68	0.5	65	66	80	103 000	211 000	6 000	LRT 606845
89	45	45.5	1	70	2	65	68	84	114 000	228 000	5 500	LRT 607045
89	45	45.5	1	70	—	65	68	84	147 000	336 000	2 000	LRTZ 607045
90	25	—	1	72	1	70	70.5	85	62 700	113 000	5 500	LRT 657225
90	35	—	1	73	1	70	71	85	80 400	181 000	5 500	LRT 657335
90	45	—	1	72	0.5	70	70.5	85	108 000	227 000	5 500	LRT 657245
95	25	—	1	80	0.3	75	78	90	59 400	137 000	5 000	LRT 708025
95	35	—	1	80	1	75	78	90	78 100	195 000	5 000	LRT 708035
100	30	—	1	80	1.5	75	78	95	83 200	158 000	5 000	LRT 708030
100	54	—	1	80	1	75	78	95	134 000	311 000	5 000	LRT 708054

D
NA
TAFI
TRI
BRI

MACHINED TYPE NEEDLE ROLLER BEARINGS

With Inner Ring

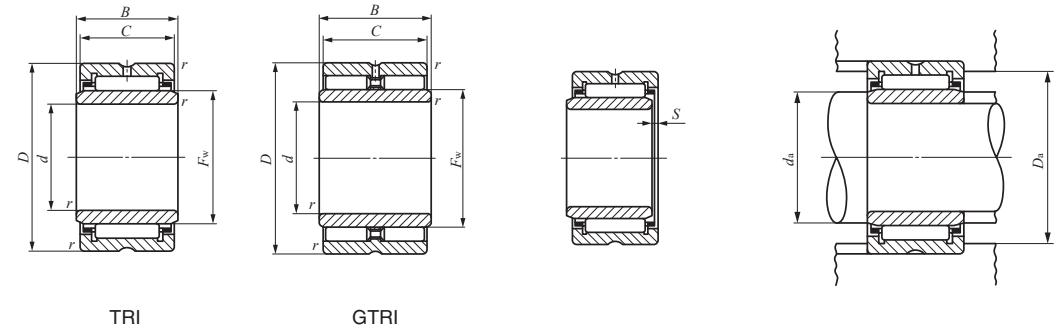


NA49 TAFI NA69

Shaft dia. 75 – 90mm

Shaft dia. mm	Identification number						Mass (Ref.)	d
	NA 49	NA 69	NA 48	TAFI	TRI	GTRI	g	
75	—	—	—	TAFI 7510525	—	—	675	75
	NA 4915	—	—	—	—	—	810	75
	—	—	—	TAFI 7510535	—	—	945	75
	—	NA 6915	—	—	—	—	1 480	75
	—	—	—	—	TRI 7510845	—	1 340	75
	—	—	—	—	—	GTRI 7510845	1 440	75
80	—	—	—	TAFI 8011025	—	—	710	80
	NA 4916	—	—	—	—	—	855	80
	—	—	—	TAFI 8011035	—	—	995	80
	—	NA 6916	—	—	—	—	1 560	80
85	—	—	—	TAFI 8511526	—	—	775	85
	—	—	—	TAFI 8511536	—	—	1 080	85
	NA 4917	—	—	—	—	—	1 280	85
	—	NA 6917	—	—	—	—	2 340	85
	—	—	—	—	TRI 8511850	—	1 640	85
	—	—	—	—	TRI 8512045	—	1 610	85
	—	—	—	—	—	GTRI 8511850	1 780	85
	—	—	—	—	—	GTRI 8512045	1 720	85
90	—	—	—	TAFI 9012026	—	—	820	90
	—	—	—	TAFI 9012036	—	—	1 140	90
	NA 4918	—	—	—	—	—	1 350	90
	—	—	—	—	TRI 9012550	—	1 870	90
	—	NA 6918	—	—	—	—	2 460	90
	—	—	—	—	—	GTRI 9012550	2 020	90

Notes⁽¹⁾ Minimum allowable value of chamfer dimension *r*
⁽²⁾ Allowable axial shift amount of inner ring to outer ring
⁽³⁾ Allowable rotational speed applies to oil lubrication. For grease lubrication, a maximum of 60% of this value is allowable.
 Remarks1. The outer ring has an oil groove and an oil hole.
 2. No grease is prepacked. Perform proper lubrication.



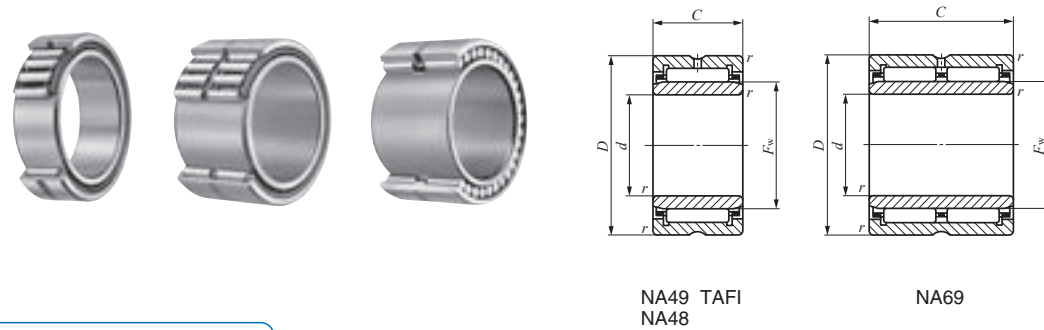
TRI GTRI

Boundary dimensions mm						Standard mounting dimensions mm			Basic dynamic load rating	Basic static load rating	Allowable rotational speed ⁽³⁾	Assembled inner ring
D	C	B	<i>r</i> _{s min} ⁽¹⁾	<i>F</i> _w ⁽²⁾	<i>S</i> ⁽²⁾	Min.	<i>d</i> _a Max.	<i>D</i> _a Max.	C N	C ₀ N	min ⁻¹	
105	25	—	1	85	0.5	80	83	100	76 300	145 000	4 500	LRT 758525
105	30	—	1	85	1.5	80	83	100	86 200	169 000	4 500	LRT 758530
105	35	—	1	85	1.5	80	83	100	102 000	210 000	4 500	LRT 758535
105	54	—	1	85	1	80	83	100	138 000	331 000	4 500	LRT 758554
108	45	45.5	1	83	2.5	80	81	103	146 000	270 000	5 000	LRT 758345
108	45	45.5	1	83	—	80	81	103	190 000	396 000	1 800	LRTZ 758345
110	25	—	1	90	0.5	85	88	105	77 300	150 000	4 500	LRT 809025
110	30	—	1	90	1.5	85	88	105	87 300	175 000	4 500	LRT 809030
110	35	—	1	90	1.5	85	88	105	103 000	217 000	4 500	LRT 809035
110	54	—	1	90	1	85	88	105	143 000	351 000	4 500	LRT 809054
115	26	—	1	95	1	90	93	110	79 700	159 000	4 000	LRT 859526
115	36	—	1	95	2	90	93	110	106 000	231 000	4 000	LRT 859536
120	35	—	1.1	100	1	91.5	98	113.5	110 000	244 000	4 000	LRT 8510035
120	63	—	1.1	100	0.5	91.5	98	113.5	173 000	467 000	4 000	LRT 8510063
118	50	50.5	1	93	3	90	91	113	165 000	329 000	4 500	LRT 859350
120	45	45.5	1.5	95	2.5	93	93.5	112	155 000	305 000	4 000	LRT 859545
118	50	50.5	1	93	—	90	91	113	224 000	509 000	1 600	LRTZ 859350
120	45	45.5	1.5	95	—	93	93.5	112	204 000	455 000	1 600	LRTZ 859545
120	26	—	1	100	1	95	98	115	82 400	168 000	4 000	LRT 9010026
120	36	—	1	100	2	95	98	115	110 000	244 000	4 000	LRT 9010036
125	35	—	1.1	105	1	96.5	103	118.5	113 000	258 000	4 000	LRT 9010535
125	50	50.5	1.5	100	3	98	98.5	117	172 000	355 000	4 000	LRT 9010050
125	63	—	1.1	105	0.5	96.5	103	118.5	178 000	490 000	4 000	LRT 9010563
125	50	50.5	1.5	100	—	98	98.5	117	234 000	549 000	1 500	LRTZ 9010050

D
NA
TAFI
TRI
BRI

MACHINED TYPE NEEDLE ROLLER BEARINGS

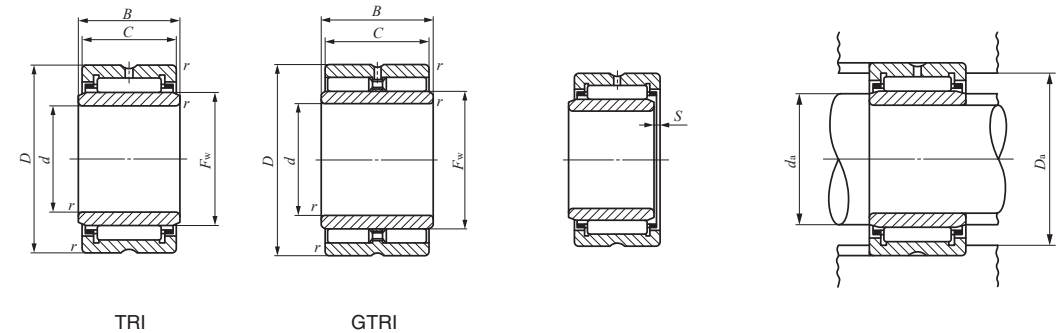
With Inner Ring



Shaft dia. 95 – 150mm

Shaft dia. mm	Identification number						Mass (Ref.) g	d
	NA 49	NA 69	NA 48	TAFI	TRI	GTRI		
95	—	—	—	TAFI 9512526	—	—	860	95
	—	—	—	TAFI 9512536	—	—	1 190	95
	NA 4919	—	—	—	—	—	1 420	95
	—	NA 6919	—	—	—	—	2 580	95
100	—	—	—	TAFI 10013030	—	—	1 040	100
	—	—	—	TAFI 10013040	—	—	1 380	100
	NA 4920	—	—	—	TRI 10013550	—	2 040	100
105	—	—	—	—	—	—	1 960	100
	—	—	—	—	—	GTRI 10013550	2 200	100
110	—	—	NA 4822	—	—	—	3 020	105
	NA 4922	—	—	—	—	GTRI 10515350	3 270	105
120	—	—	NA 4824	—	—	—	—	—
	NA 4924	—	—	—	—	—	1 300	120
125	—	—	—	—	TRI 12517860	—	4 780	125
	—	—	—	—	—	GTRI 12517860	5 180	125
130	—	—	NA 4826	—	—	—	1 960	130
	NA 4926	—	—	—	—	—	4 030	130
135	—	—	—	—	TRI 13518860	—	5 100	135
	—	—	—	—	—	GTRI 13518860	5 530	135
140	—	—	NA 4828	—	—	—	2 100	140
	NA 4928	—	—	—	—	—	4 290	140
150	—	—	NA 4830	—	—	—	2 880	150
	NA 4930	—	—	—	—	—	6 380	150

Notes⁽¹⁾ Minimum allowable value of chamfer dimension *r*
⁽²⁾ Allowable axial shift amount of inner ring to outer ring
⁽³⁾ Allowable rotational speed applies to oil lubrication. For grease lubrication, a maximum of 60% of this value is allowable.
 Remarks1. The outer ring has an oil groove and an oil hole.
 2. No grease is prepacked. Perform proper lubrication.



Boundary dimensions mm						Standard mounting dimensions mm			Basic dynamic load rating <i>C</i> N	Basic static load rating <i>C</i> ₀ N	Allowable rotational speed ⁽³⁾ min ⁻¹	Assembled inner ring
<i>D</i>	<i>C</i>	<i>B</i>	<i>r</i> _{s min} ⁽¹⁾	<i>F</i> _w ⁽²⁾	<i>S</i> ⁽²⁾	Min.	<i>d</i> _a Max.	<i>D</i> _a Max.				
125	26	—	1	105	1	100	103	120	84 700	178 000	4 000	LRT 9510526
125	36	—	1	105	2	100	103	120	113 000	258 000	4 000	LRT 9510536
130	35	—	1.1	110	1	101.5	108	123.5	116 000	271 000	3 500	LRT 9511035
130	63	—	1.1	110	0.5	101.5	108	123.5	182 000	514 000	3 500	LRT 9511063
130	30	—	1	110	0.5	105	108	125	106 000	240 000	3 500	LRT 10011030
130	40	—	1	110	1.5	105	108	125	134 000	324 000	3 500	LRT 10011040
135	50	50.5	1.5	110	3	108	108.5	127	183 000	395 000	3 500	LRT 10011050
140	40	—	1.1	115	1	106.5	113	133.5	145 000	329 000	3 500	LRT 10011540
135	50	50.5	1.5	110	—	108	108.5	127	245 000	603 000	1 400	LRTZ 10011050
153	50	50.5	1.5	115	3	113	113.5	145	233 000	414 000	3 500	LRT 10511550
153	50	50.5	1.5	115	—	113	113.5	145	315 000	614 000	1 300	LRTZ 10511550
140	30	—	1	120	1	115	118	135	93 200	239 000	3 500	LRT 11012030
150	40	—	1.1	125	1	116.5	123	143.5	152 000	357 000	3 000	LRT 11012540
150	30	—	1	130	1	125	128	145	96 900	259 000	3 000	LRT 12013030
165	45	—	1.1	135	2	126.5	133	158.5	187 000	435 000	3 000	LRT 12013545
178	60	60.5	1.5	140	2.5	133	138	170	307 000	625 000	3 000	LRT 12514060
178	60	60.5	1.5	140	—	133	138	170	409 000	923 000	1 100	LRTZ 12514060
165	35	—	1.1	145	1	136.5	143	158.5	116 000	340 000	3 000	LRT 13014535
180	50	—	1.5	150	2.5	138	148	172	215 000	540 000	2 500	LRT 13015050
188	60	60.5	1.5	150	2.5	143	148	180	320 000	675 000	2 500	LRT 13515060
188	60	60.5	1.5	150	—	143	148	180	423 000	989 000	1 000	LRTZ 13515060
175	35	—	1.1	155	1	146.5	153	168.5	120 000	363 000	2 500	LRT 14015535
190	50	—	1.5	160	2.5	148	158	182	224 000	580 000	2 500	LRT 14016050
190	40	—	1.1	165	1.5	156.5	163	183.5	168 000	446 000	2 500	LRT 15016540
210	60	—	2	170	3	159	168	201	324 000	712 000	2 500	LRT 15017060

NA
TAFI
TRI
BRI

MACHINED TYPE NEEDLE ROLLER BEARINGS

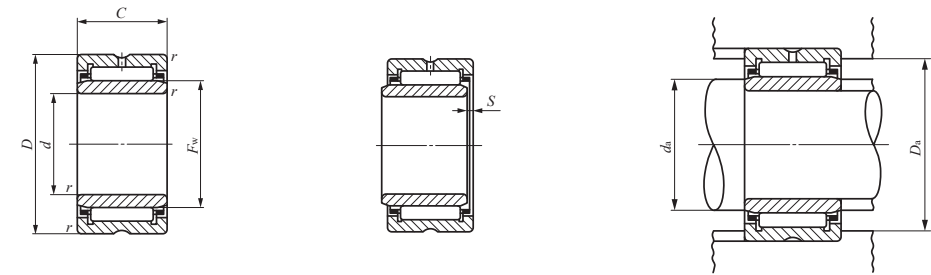
With Inner Ring



Shaft dia. 160 – 340mm

Shaft dia. mm	Identification number						Mass (Ref.) g	<i>d</i>
	NA 49	NA 69	NA 48	TAFI	TRI	GTRI		
160	—	—	NA 4832	—	—	—	3 050	160
	NA 4932	—	—	—	—	—	6 750	160
170	—	—	NA 4834	—	—	—	4 120	170
	NA 4934	—	—	—	—	—	7 110	170
180	—	—	NA 4836	—	—	—	4 340	180
	NA 4936	—	—	—	—	—	10 200	180
190	—	—	NA 4838	—	—	—	5 760	190
	NA 4938	—	—	—	—	—	10 700	190
200	—	—	NA 4840	—	—	—	6 040	200
	NA 4940	—	—	—	—	—	15 400	200
220	—	—	NA 4844	—	—	—	6 570	220
	NA 4944	—	—	—	—	—	16 700	220
240	—	—	NA 4848	—	—	—	10 200	240
	NA 4948	—	—	—	—	—	18 000	240
260	—	—	NA 4852	—	—	—	11 000	260
	NA 4952	—	—	—	—	—	31 100	260
280	—	—	NA 4856	—	—	—	15 800	280
	NA 4956	—	—	—	—	—	33 100	280
300	—	—	NA 4860	—	—	—	22 300	300
	NA 4960	—	—	—	—	—	51 400	300
320	—	—	NA 4864	—	—	—	23 700	320
	NA 4964	—	—	—	—	—	54 400	320
340	—	—	NA 4868	—	—	—	25 000	340
	NA 4968	—	—	—	—	—	57 300	340

Notes⁽¹⁾ Minimum allowable value of chamfer dimension *r*
⁽²⁾ Allowable axial shift amount of inner ring to outer ring
⁽³⁾ Allowable rotational speed applies to oil lubrication. For grease lubrication, a maximum of 60% of this value is allowable.
 Remarks1. The outer ring has an oil groove and an oil hole.
 2. No grease is prepacked. Perform proper lubrication.

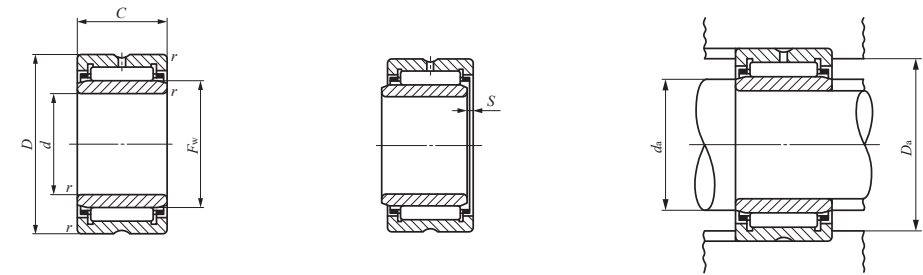


NA49 NA48

Boundary dimensions mm					Standard mounting dimensions mm			Basic dynamic load rating <i>C</i> N	Basic static load rating <i>C</i> ₀ N	Allowable rotational speed ⁽³⁾ min ⁻¹	Assembled inner ring	
<i>D</i>	<i>C</i>	<i>B</i>	<i>r</i> _{s min} ⁽¹⁾	<i>F</i> _w ⁽²⁾	<i>S</i> ⁽²⁾	Min. <i>d</i> _a	Max. <i>D</i> _a					
200	40	—	1.1	175	1.5	166.5	173	193.5	173 000	474 000	2 500	LRT 16017540
220	60	—	2	180	3	169	178	211	337 000	761 000	1 900	LRT 16018060
215	45	—	1.1	185	1.5	176.5	183	208.5	211 000	567 000	1 900	LRT 17018545
230	60	—	2	190	3	179	188	221	347 000	810 000	1 900	LRT 17019060
225	45	—	1.1	195	1.5	186.5	193	218.5	218 000	602 000	1 900	LRT 18019545
250	69	—	2	205	3	189	203	241	434 000	989 000	1 900	LRT 18020569
240	50	—	1.5	210	1.5	198	208	232	249 000	726 000	1 800	LRT 19021050
260	69	—	2	215	3	199	213	251	440 000	1 020 000	1 700	LRT 19021569
250	50	—	1.5	220	1.5	208	218	242	255 000	766 000	1 600	LRT 20022050
280	80	—	2.1	225	4	211	223	269	518 000	1 120 000	1 600	LRT 20022580
270	50	—	1.5	240	1.5	228	238	262	266 000	833 000	1 500	LRT 22024050
300	80	—	2.1	245	4	231	243	289	536 000	1 200 000	1 400	LRT 22024580
300	60	—	2	265	2	249	262	291	345 000	1 150 000	1 300	LRT 24026560
320	80	—	2.1	265	4	251	262	309	565 000	1 320 000	1 300	LRT 24026580
320	60	—	2	285	2	269	282	311	354 000	1 220 000	1 100	LRT 26028560
360	100	—	2.1	290	4	271	287	349	847 000	1 900 000	1 100	LRT 260290100
350	69	—	2	305	2.5	289	302	341	486 000	1 550 000	950	LRT 28030569
380	100	—	2.1	310	4	291	307	369	877 000	2 040 000	950	LRT 280310100
380	80	—	2.1	330	2.5	311	327	369	610 000	1 900 000	900	LRT 30033080
420	118	—	3	340	4	313	337	407	1 130 000	2 650 000	850	LRT 300340118
400	80	—	2.1	350	2.5	331	347	389	635 000	2 040 000	750	LRT 32035080
440	118	—	3	360	4	333	357	427	1 170 000	2 830 000	750	LRT 320360118
420	80	—	2.1	370	2.5	351	367	409	651 000	2 140 000	700	LRT 34037080
460	118	—	3	380	4	353	377	447	1 220 000	3 020 000	700	LRT 340380118

MACHINED TYPE NEEDLE ROLLER BEARINGS

With Inner Ring



NA49 NA48

Shaft dia. 360 – 440mm

Shaft dia. mm	Identification number						Mass (Ref.) g	d
	NA 49	NA 69	NA 48	TAFI	TRI	GTRI		
360	—	—	NA 4872	—	—	—	26 400	360
	NA 4972	—	—	—	—	—	60 200	360
380	—	—	NA 4876	—	—	—	44 600	380
	NA 4976	—	—	—	—	—	90 300	380
400	NA 4980	—	—	—	—	—	94 400	400
420	NA 4984	—	—	—	—	—	98 500	420
440	NA 4988	—	—	—	—	—	131 000	440

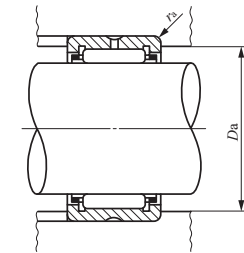
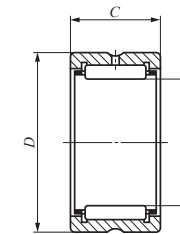
Notes⁽¹⁾ Minimum allowable value of chamfer dimension *r*
⁽²⁾ Allowable axial shift amount of inner ring to outer ring
⁽³⁾ Allowable rotational speed applies to oil lubrication. For grease lubrication, a maximum of 60% of this value is allowable.
 Remarks1. The outer ring has an oil groove and an oil hole.
 2. No grease is prepacked. Perform proper lubrication.

Boundary dimensions mm						Standard mounting dimensions mm			Basic dynamic load rating <i>C</i> N	Basic static load rating <i>C</i> ₀ N	Allowable rotational speed ⁽³⁾ min ⁻¹	Assembled inner ring
<i>D</i>	<i>C</i>	<i>B</i>	<i>r</i> _{s min} ⁽¹⁾	<i>F</i> _w ⁽²⁾	<i>S</i> ⁽²⁾	Min.	<i>d</i> _a Max.	<i>D</i> _a Max.				
440	80	—	2.1	390	2.5	371	387	429	680 000	2 320 000	650	LRT 36039080
480	118	—	3	400	4	373	397	467	1 260 000	3 200 000	600	LRT 360400118
480	100	—	2.1	415	3	391	412	469	951 000	2 860 000	600	LRT 380415100
520	140	—	4	430	5	396	427	504	1 540 000	4 030 000	500	LRT 380430140
540	140	—	4	450	5	416	447	524	1 590 000	4 270 000	500	LRT 400450140
560	140	—	4	470	5	436	467	544	1 640 000	4 510 000	500	LRT 420470140
600	160	—	4	490	5	456	487	584	1 910 000	5 140 000	400	LRT 440490160

D
NA
TAFI
TRI
BRI

MACHINED TYPE NEEDLE ROLLER BEARINGS

Without Inner Ring, Inch Series



BR

Shaft dia. 15.875 — 47.625mm

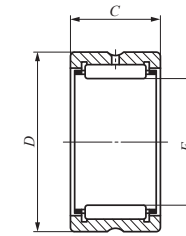
Shaft dia. mm (inch)	Identification number	Mass (Ref.) g	Boundary dimensions mm(inch)			Standard mounting dimensions mm	
			F_w	D	C	D_a Max.	$r_{as\ max}^{(1)}$
15.875 (5/8)	BR 101812	49	15.875 (5/8)	28.575 (1 1/8)	19.050 (3/4)	24.5	0.6
19.050 (3/4)	BR 122012	56	19.050 (3/4)	31.750 (1 1/4)	19.050 (3/4)	26.5	1
	BR 122016	75	19.050 (3/4)	31.750 (1 1/4)	25.400 (1)	26.5	1
22.225 (7/8)	BR 142212	63	22.225 (7/8)	34.925 (1 3/8)	19.050 (3/4)	29.7	1
	BR 142216	84.5	22.225 (7/8)	34.925 (1 3/8)	25.400 (1)	29.7	1
25.400 (1)	BR 162412	69	25.400 (1)	38.100 (1 1/2)	19.050 (3/4)	32.9	1
	BR 162416	92.5	25.400 (1)	38.100 (1 1/2)	25.400 (1)	32.9	1
28.575 (1 1/8)	BR 182616	102	28.575 (1 1/8)	41.275 (1 5/8)	25.400 (1)	36	1
	BR 182620	128	28.575 (1 1/8)	41.275 (1 5/8)	31.750 (1 1/4)	36	1
31.750 (1 1/4)	BR 202816	110	31.750 (1 1/4)	44.450 (1 3/4)	25.400 (1)	39.2	1
	BR 202820	138	31.750 (1 1/4)	44.450 (1 3/4)	31.750 (1 1/4)	39.2	1
34.925 (1 3/8)	BR 223016	119	34.925 (1 3/8)	47.625 (1 7/8)	25.400 (1)	42.4	1
	BR 223020	149	34.925 (1 3/8)	47.625 (1 7/8)	31.750 (1 1/4)	42.4	1
38.100 (1 1/2)	BR 243316	149	38.100 (1 1/2)	52.388 (2 1/16)	25.400 (1)	45.1	1.5
	BR 243320	187	38.100 (1 1/2)	52.388 (2 1/16)	31.750 (1 1/4)	45.1	1.5
41.275 (1 5/8)	BR 263516	158	41.275 (1 5/8)	55.562 (2 3/16)	25.400 (1)	48.3	1.5
	BR 263520	199	41.275 (1 5/8)	55.562 (2 3/16)	31.750 (1 1/4)	48.3	1.5
44.450 (1 3/4)	BR 283716	170	44.450 (1 3/4)	58.738 (2 5/16)	25.400 (1)	51.5	1.5
	BR 283720	215	44.450 (1 3/4)	58.738 (2 5/16)	31.750 (1 1/4)	51.5	1.5
	BR 283820	250	44.450 (1 3/4)	60.325 (2 3/8)	31.750 (1 1/4)	53.1	1.5
47.625 (1 7/8)	BR 303920	225	47.625 (1 7/8)	61.912 (2 7/16)	31.750 (1 1/4)	54.7	1.5

Notes⁽¹⁾ Maximum permissible corner radius of the housing
⁽²⁾ Allowable rotational speed applies to oil lubrication. For grease lubrication, a maximum of 60% of this value is allowable.
 Remarks1. The outer ring has an oil groove and an oil hole.
 2. No grease is prepacked. Perform proper lubrication.

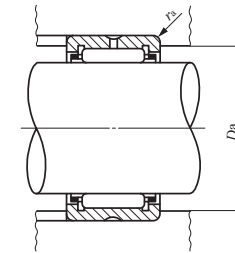
Basic dynamic load rating C N	Basic static load rating C_0 N	Allowable rotational speed ⁽²⁾ min ⁻¹
18 900	19 700	25 000
21 700	24 400	20 000
27 600	33 100	20 000
23 000	27 100	18 000
29 100	36 800	18 000
25 300	31 900	16 000
32 100	43 300	16 000
34 900	49 900	14 000
43 200	65 600	14 000
36 000	53 500	13 000
44 600	70 300	13 000
38 500	60 000	11 000
47 700	78 900	11 000
43 700	66 900	11 000
54 200	88 200	11 000
44 800	70 900	9 500
55 600	93 400	9 500
47 500	78 200	9 000
58 900	103 000	9 000
58 900	103 000	9 000
60 100	108 000	8 500

MACHINED TYPE NEEDLE ROLLER BEARINGS

Without Inner Ring, Inch Series



BR



Shaft dia. 50.800 – 101.600mm

Shaft dia. mm (inch)	Identification number	Mass (Ref.) g	Boundary dimensions mm(inch)			Standard mounting dimensions mm	
			F_w	D	C	D_a Max.	$r_{as\ max}^{(1)}$
50.800 (2)	BR 324116	190	50.800 (2)	65.088 (2 9/16)	25.400 (1)	57.8	1.5
	BR 324120	240	50.800 (2)	65.088 (2 9/16)	31.750 (1 1/4)	57.8	1.5
57.150 (2 1/4)	BR 364824	435	57.150 (2 1/4)	76.200 (3)	38.100 (1 1/2)	69	1.5
	BR 364828	510	57.150 (2 1/4)	76.200 (3)	44.450 (1 3/4)	69	1.5
63.500 (2 1/2)	BR 405224	475	63.500 (2 1/2)	82.550 (3 1/4)	38.100 (1 1/2)	74.3	2
	BR 405228	555	63.500 (2 1/2)	82.550 (3 1/4)	44.450 (1 3/4)	74.3	2
69.850 (2 3/4)	BR 445624	510	69.850 (2 3/4)	88.900 (3 1/2)	38.100 (1 1/2)	80.7	2
	BR 445628	600	69.850 (2 3/4)	88.900 (3 1/2)	44.450 (1 3/4)	80.7	2
76.200 (3)	BR 486024	555	76.200 (3)	95.250 (3 3/4)	38.100 (1 1/2)	87	2
	BR 486028	650	76.200 (3)	95.250 (3 3/4)	44.450 (1 3/4)	87	2
82.550 (3 1/4)	BR 526828	990	82.550 (3 1/4)	107.950 (4 1/4)	44.450 (1 3/4)	99.7	2
	BR 526832	1 140	82.550 (3 1/4)	107.950 (4 1/4)	50.800 (2)	99.7	2
88.900 (3 1/2)	BR 567232	1 220	88.900 (3 1/2)	114.300 (4 1/2)	50.800 (2)	106.1	2
95.250 (3 3/4)	BR 607632	1 290	95.250 (3 3/4)	120.650 (4 3/4)	50.800 (2)	111.4	2.5
101.600 (4)	BR 648032	1 370	101.600 (4)	127.000 (5)	50.800 (2)	117.8	2.5

Notes⁽¹⁾ Maximum permissible corner radius of the housing
⁽²⁾ Allowable rotational speed applies to oil lubrication. For grease lubrication, a maximum of 60% of this value is allowable.
 Remarks1. In bearings with a roller set bore diameter F_w of 69.850 mm or less, the outer ring has an oil groove and an oil hole. In others, the outer ring has an oil groove and two oil holes.
 2. No grease is prepacked. Perform proper lubrication.

Basic dynamic load rating C N	Basic static load rating C_0 N	Allowable rotational speed ⁽²⁾ min ⁻¹
51 000	89 400	8 000
63 200	118 000	8 000
90 300	158 000	7 000
105 000	191 000	7 000
94 600	174 000	6 500
110 000	210 000	6 500
98 700	189 000	5 500
114 000	228 000	5 500
105 000	211 000	5 500
122 000	255 000	5 500
141 000	259 000	5 000
154 000	290 000	5 000
162 000	316 000	4 500
169 000	342 000	4 000
176 000	368 000	4 000

D
NA
TAFI
TRI
BRI

MACHINED TYPE NEEDLE ROLLER BEARINGS

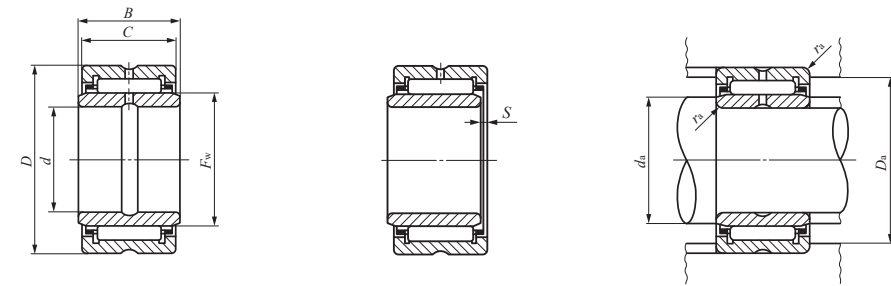
With Inner Ring, Inch Series



Shaft dia. 9.525 – 41.275mm

Shaft dia. mm (inch)	Identification number	Mass (Ref.) g	Boundary dimensions mm(inch)					⁽¹⁾ S
			d	D	C	B	F _w	
9.525 (3/8)	BRI 61812	67.5	9.525 (3/8)	28.575 (1 1/8)	19.050 (3/4)	19.300	15.875 (5/8)	0.3
		106	12.700 (1/2)	31.750 (1 1/4)	19.050 (3/4)	19.300	19.050 (3/4)	0.5
12.700 (1/2)	BRI 82012 BRI 82016	79.5	12.700 (1/2)	31.750 (1 1/4)	19.050 (3/4)	19.300	19.050 (3/4)	0.3
		122	15.875 (5/8)	34.925 (1 3/8)	19.050 (3/4)	19.300	22.225 (7/8)	0.5
15.875 (5/8)	BRI 102212 BRI 102216	91	15.875 (5/8)	34.925 (1 3/8)	19.050 (3/4)	19.300	22.225 (7/8)	0.3
		122	15.875 (5/8)	34.925 (1 3/8)	25.400 (1)	25.650	22.225 (7/8)	0.5
19.050 (3/4)	BRI 122412 BRI 122416	102	19.050 (3/4)	38.100 (1 1/2)	19.050 (3/4)	19.300	25.400 (1)	0.3
		136	19.050 (3/4)	38.100 (1 1/2)	25.400 (1)	25.650	25.400 (1)	0.5
22.225 (7/8)	BRI 142616 BRI 142620	152	22.225 (7/8)	41.275 (1 5/8)	25.400 (1)	25.650	28.575 (1 1/8)	0.5
		190	22.225 (7/8)	41.275 (1 5/8)	31.750 (1 1/4)	32.000	28.575 (1 1/8)	0.5
25.400 (1)	BRI 162816 BRI 162820	166	25.400 (1)	44.450 (1 3/4)	25.400 (1)	25.650	31.750 (1 1/4)	0.5
		210	25.400 (1)	44.450 (1 3/4)	31.750 (1 1/4)	32.000	31.750 (1 1/4)	0.5
28.575 (1 1/8)	BRI 183016 BRI 183020	182	28.575 (1 1/8)	47.625 (1 7/8)	25.400 (1)	25.650	34.925 (1 3/8)	0.5
		225	28.575 (1 1/8)	47.625 (1 7/8)	31.750 (1 1/4)	32.000	34.925 (1 3/8)	0.5
31.750 (1 1/4)	BRI 203316 BRI 203320	220	31.750 (1 1/4)	52.388 (2 1/16)	25.400 (1)	25.650	38.100 (1 1/2)	0.5
		275	31.750 (1 1/4)	52.388 (2 1/16)	31.750 (1 1/4)	32.000	38.100 (1 1/2)	0.5
34.925 (1 3/8)	BRI 223516 BRI 223520	235	34.925 (1 3/8)	55.562 (2 3/16)	25.400 (1)	25.650	41.275 (1 5/8)	0.5
		295	34.925 (1 3/8)	55.562 (2 3/16)	31.750 (1 1/4)	32.000	41.275 (1 5/8)	0.5
38.100 (1 1/2)	BRI 243716 BRI 243720 BRI 243820 BRI 243920	250	38.100 (1 1/2)	58.738 (2 5/16)	25.400 (1)	25.650	44.450 (1 3/4)	0.5
		315	38.100 (1 1/2)	58.738 (2 5/16)	31.750 (1 1/4)	32.000	44.450 (1 3/4)	0.5
		350	38.100 (1 1/2)	60.325 (2 3/8)	31.750 (1 1/4)	32.000	44.450 (1 3/4)	0.5
		380	38.100 (1 1/2)	61.912 (2 7/16)	31.750 (1 1/4)	32.000	47.625 (1 7/8)	0.5
41.275 (1 5/8)	BRI 264116 BRI 264120	325	41.275 (1 5/8)	65.088 (2 9/16)	25.400 (1)	25.650	50.800 (2)	0.5
		410	41.275 (1 5/8)	65.088 (2 9/16)	31.750 (1 1/4)	32.000	50.800 (2)	0.5

Notes⁽¹⁾ Allowable axial shift amount of inner ring to outer ring
⁽²⁾ Maximum permissible corner radius of the shaft or housing
⁽³⁾ Allowable rotational speed applies to oil lubrication. For grease lubrication, a maximum of 60% of this value is allowable.
 Remarks1. The inner ring and the outer ring each have an oil groove and an oil hole.
 2. No grease is prepacked. Perform proper lubrication.



BRI

Standard mounting dimensions mm				Basic dynamic load rating C N	Basic static load rating C ₀ N	Allowable rotational speed ⁽³⁾ min ⁻¹	Assembled inner ring
Min.	Max.	Max.	r _{as max} ⁽²⁾				
14	14.5	24.5	0.6	18 900	19 700	25 000	LRB 61012
17.5	18	26.5	1	21 700	24 400	20 000	LRB 81212
17.5	18	26.5	1	27 600	33 100	20 000	LRB 81216
21	21.2	29.7	1	23 000	27 100	18 000	LRB 101412
21	21.2	29.7	1	29 100	36 800	18 000	LRB 101416
24	24.4	32.9	1	25 300	31 900	16 000	LRB 121612
24	24.4	32.9	1	32 100	43 300	16 000	LRB 121616
27	27.5	36	1	34 900	49 900	14 000	LRB 141816
27	27.5	36	1	43 200	65 600	14 000	LRB 141820
30.5	30.7	39.2	1	36 000	53 500	13 000	LRB 162016
30.5	30.7	39.2	1	44 600	70 300	13 000	LRB 162020
33.5	33.9	42.4	1	38 500	60 000	11 000	LRB 182216
33.5	33.9	42.4	1	47 700	78 900	11 000	LRB 182220
37	37.1	45.1	1.5	43 700	66 900	11 000	LRB 202416
37	37.1	45.1	1.5	54 200	88 200	11 000	LRB 202420
40.2	40.2	48.3	1.5	44 800	70 900	9 500	LRB 222616
40.2	40.2	48.3	1.5	55 600	93 400	9 500	LRB 222620
43.3	43.4	51.5	1.5	47 500	78 200	9 000	LRB 242816
43.3	43.4	51.5	1.5	58 900	103 000	9 000	LRB 242820
43.3	43.4	53.1	1.5	58 900	103 000	9 000	LRB 242820
43.3	43.4	54.7	1.5	60 100	108 000	8 500	LRB 243020
48	49	57.8	1.5	51 000	89 400	8 000	LRB 263216
48	49	57.8	1.5	63 200	118 000	8 000	LRB 263220

MACHINED TYPE NEEDLE ROLLER BEARINGS

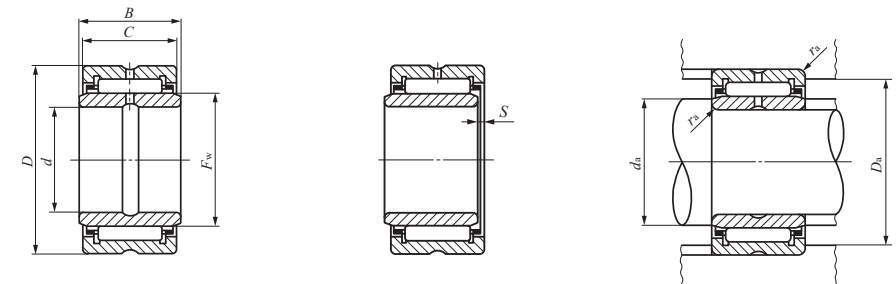
With Inner Ring, Inch Series



Shaft dia. 44.450 — 88.900mm

Shaft dia. mm (inch)	Identification number	Mass (Ref.) g	Boundary dimensions mm(inch)					
			<i>d</i>	<i>D</i>	<i>C</i>	<i>B</i>	<i>F_w</i>	<i>S</i> ⁽¹⁾
44.450 (1 3/4)	BRI 284824	735	44.450 (1 3/4)	76.200 (3)	38.100 (1 1/2)	38.350	57.150 (2 1/4)	1
	BRI 284828	855	44.450 (1 3/4)	76.200 (3)	44.450 (1 3/4)	44.700	57.150 (2 1/4)	1
50.800 (2)	BRI 325224	810	50.800 (2)	82.550 (3 1/4)	38.100 (1 1/2)	38.350	63.500 (2 1/2)	1
	BRI 325228	945	50.800 (2)	82.550 (3 1/4)	44.450 (1 3/4)	44.700	63.500 (2 1/2)	1
57.150 (2 1/4)	BRI 365624	885	57.150 (2 1/4)	88.900 (3 1/2)	38.100 (1 1/2)	38.350	69.850 (2 3/4)	1
	BRI 365628	1 040	57.150 (2 1/4)	88.900 (3 1/2)	44.450 (1 3/4)	44.700	69.850 (2 3/4)	1
63.500 (2 1/2)	BRI 406024	965	63.500 (2 1/2)	95.250 (3 3/4)	38.100 (1 1/2)	38.350	76.200 (3)	1
	BRI 406028	1 130	63.500 (2 1/2)	95.250 (3 3/4)	44.450 (1 3/4)	44.700	76.200 (3)	1
69.850 (2 3/4)	BRI 446828	1 520	69.850 (2 3/4)	107.950 (4 1/4)	44.450 (1 3/4)	44.700	82.550 (3 1/4)	1.5
	BRI 446832	1 740	69.850 (2 3/4)	107.950 (4 1/4)	50.800 (2)	51.050	82.550 (3 1/4)	3
76.200 (3)	BRI 487232	1 860	76.200 (3)	114.300 (4 1/2)	50.800 (2)	51.050	88.900 (3 1/2)	3
82.550 (3 1/4)	BRI 527632	1 980	82.550 (3 1/4)	120.650 (4 3/4)	50.800 (2)	51.050	95.250 (3 3/4)	3
88.900 (3 1/2)	BRI 568032	2 120	88.900 (3 1/2)	127.000 (5)	50.800 (2)	51.050	101.600 (4)	3

Notes⁽¹⁾ Allowable axial shift amount of inner ring to outer ring
⁽²⁾ Maximum permissible corner radius of the shaft or housing
⁽³⁾ Allowable rotational speed applies to oil lubrication. For grease lubrication, a maximum of 60% of this value is allowable.
 Remarks1. In bearings with a bearing bore diameter, *d*, of 57.150 mm or less, the outer ring has an oil groove and an oil hole. In bearings with a bearing bore diameter, *d*, of 76.200 mm or less, the inner ring has an oil groove and an oil hole. In others, the inner ring and the outer ring each have an oil groove and two oil holes.
 2. No grease is prepacked. Perform proper lubrication.



BRI

Standard mounting dimensions mm				Basic dynamic load rating <i>C</i> N	Basic static load rating <i>C₀</i> N	Allowable rotational speed ⁽³⁾ min ⁻¹	Assembled inner ring
Min.	Max.	Max.	<i>r_{as max}</i> ⁽²⁾				
52.5	55	69	1.5	90 300	158 000	7 000	LRB 283624
52.5	55	69	1.5	105 000	191 000	7 000	LRB 283628
58	61	74.3	2	94 600	174 000	6 500	LRB 324024
58	61	74.3	2	110 000	210 000	6 500	LRB 324028
65	67	80.7	2	98 700	189 000	5 500	LRB 364424
65	67	80.7	2	114 000	228 000	5 500	LRB 364428
71	73	87	2	105 000	211 000	5 500	LRB 404824
71	73	87	2	122 000	255 000	5 500	LRB 404828
77	79	99.7	2	141 000	259 000	5 000	LRB 445228
77	79	99.7	2	154 000	290 000	5 000	LRB 445232
83.5	86	106.1	2	162 000	316 000	4 500	LRB 485632
91	93	111.4	2.5	169 000	342 000	4 000	LRB 526032
97	99	117.8	2.5	176 000	368 000	4 000	LRB 566432

MACHINED TYPE NEEDLE ROLLER BEARINGS

With Seal, Without Inner Ring



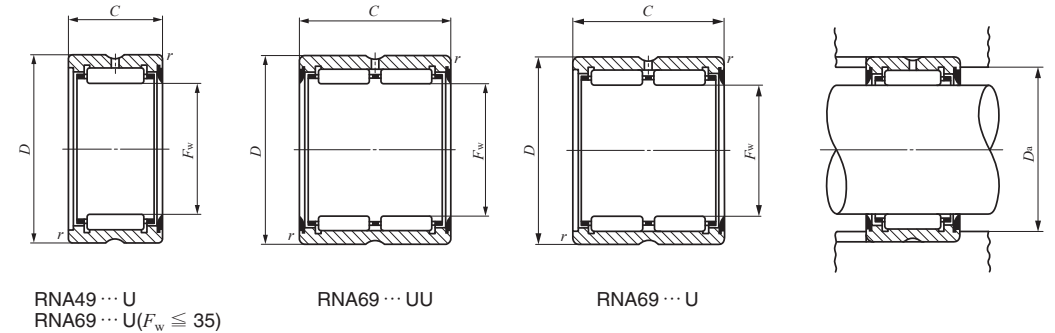
RNA49 ... UU
RNA69 ... UU ($F_w \leq 35$)

Shaft dia. 14 – 45mm

Shaft dia. mm	Identification number				Mass (Ref.) g	Boundary dimensions mm			
	With two seals	With one seal	With two seals	With one seal		F_w	D	C	$r_{s \min}^{(1)}$
14	RNA 4900UU	RNA 4900U	—	—	16.3	14	22	13	0.3
16	RNA 4901UU	RNA 4901U	—	—	17.9	16	24	13	0.3
	—	—	RNA 6901UU	RNA 6901U	30	16	24	22	0.3
18	RNA 49/14UU	RNA 49/14U	—	—	19.7	18	26	13	0.3
20	RNA 4902UU	RNA 4902U	—	—	21.5	20	28	13	0.3
	—	—	RNA 6902UU	RNA 6902U	37.5	20	28	23	0.3
22	RNA 4903UU	RNA 4903U	—	—	23	22	30	13	0.3
	—	—	RNA 6903UU	RNA 6903U	40.5	22	30	23	0.3
25	RNA 4904UU	RNA 4904U	—	—	54.5	25	37	17	0.3
	—	—	RNA 6904UU	RNA 6904U	95.5	25	37	30	0.3
28	RNA 49/22UU	RNA 49/22U	—	—	55.5	28	39	17	0.3
	—	—	RNA 69/22UU	RNA 69/22U	97.5	28	39	30	0.3
30	RNA 4905UU	RNA 4905U	—	—	63	30	42	17	0.3
	—	—	RNA 6905UU	RNA 6905U	111	30	42	30	0.3
32	RNA 49/28UU	RNA 49/28U	—	—	75.5	32	45	17	0.3
	—	—	RNA 69/28UU	RNA 69/28U	133	32	45	30	0.3
35	RNA 4906UU	RNA 4906U	—	—	71	35	47	17	0.3
	—	—	RNA 6906UU	RNA 6906U	125	35	47	30	0.3
40	RNA 49/32UU	RNA 49/32U	—	—	94.5	40	52	20	0.6
	—	—	RNA 69/32UU	RNA 69/32U	170	40	52	36	0.6
42	RNA 4907UU	RNA 4907U	—	—	112	42	55	20	0.6
	—	—	RNA 6907UU	RNA 6907U	200	42	55	36	0.6
45	RNA 49/38UU	RNA 49/38U	—	—	119	45	58	20	0.6

Notes⁽¹⁾ Minimum allowable value of chamfer dimension r
⁽²⁾ Allowable rotational speed applies to grease lubrication.

Remarks1. The outer ring has an oil groove and an oil hole.
 2. Bearings are provided with prepacked grease. Bearings with a seal on one side are not provided with prepacked grease. Perform proper lubrication for use.



RNA49 ... U
RNA69 ... U ($F_w \leq 35$)
 RNA69 ... UU
 RNA69 ... U

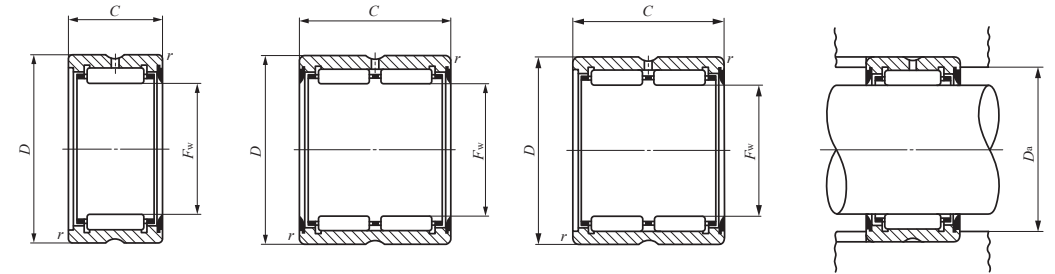
Standard mounting dimension D_a Max. mm	Basic dynamic load rating C N	Basic static load rating C_0 N	Allowable rotational speed ⁽²⁾ n min ⁻¹
20	8 080	8 490	14 000
22	8 470	9 320	12 000
22	15 500	20 400	12 000
24	9 260	10 800	11 000
26	9 570	11 600	9 500
26	18 500	27 100	9 500
28	10 300	13 100	8 500
28	19 800	30 600	8 500
35	18 000	20 500	7 500
35	33 000	44 600	7 500
37	18 300	23 700	7 000
37	33 800	52 000	7 000
40	20 300	25 100	6 500
40	39 200	58 700	6 500
43	21 000	26 800	6 000
43	38 900	59 100	6 000
45	21 500	28 400	5 500
45	40 100	63 000	5 500
48	29 400	44 200	5 000
48	50 300	88 300	5 000
51	30 100	46 300	4 500
51	51 600	92 600	4 500
54	31 600	50 400	4 000

MACHINED TYPE NEEDLE ROLLER BEARINGS

With Seal, Without Inner Ring



RNA49...UU



RNA49...U

RNA69...UU

RNA69...U

Shaft dia. 48 – 85mm

Shaft dia. mm	Identification number				Mass (Ref.) g	Boundary dimensions mm			
	With two seals	With one seal	With two seals	With one seal		F_w	D	C	$r_{s\ min}^{(1)}$
48	RNA 4908UU	RNA 4908U	—	—	150	48	62	22	0.6
	—	—	RNA 6908UU	RNA 6908U	270	48	62	40	0.6
50	RNA 49/42UU	RNA 49/42U	—	—	173	50	65	22	0.6
52	RNA 4909UU	RNA 4909U	—	—	197	52	68	22	0.6
	—	—	RNA 6909UU	RNA 6909U	355	52	68	40	0.6
55	RNA 49/48UU	RNA 49/48U	—	—	187	55	70	22	0.6
58	RNA 4910UU	RNA 4910U	—	—	177	58	72	22	0.6
	—	—	RNA 6910UU	RNA 6910U	320	58	72	40	0.6
60	RNA 49/52UU	RNA 49/52U	—	—	200	60	75	22	0.6
63	RNA 4911UU	RNA 4911U	—	—	265	63	80	25	1
	—	—	RNA 6911UU	RNA 6911U	470	63	80	45	1
65	RNA 49/58UU	RNA 49/58U	—	—	275	65	82	25	1
68	RNA 4912UU	RNA 4912U	—	—	285	68	85	25	1
	—	—	RNA 6912UU	RNA 6912U	505	68	85	45	1
70	RNA 49/62UU	RNA 49/62U	—	—	320	70	88	25	1
72	RNA 4913UU	RNA 4913U	—	—	325	72	90	25	1
	—	—	RNA 6913UU	RNA 6913U	580	72	90	45	1
75	RNA 49/68UU	RNA 49/68U	—	—	465	75	95	30	1
80	RNA 4914UU	RNA 4914U	—	—	495	80	100	30	1
	—	—	RNA 6914UU	RNA 6914U	910	80	100	54	1
85	RNA 4915UU	RNA 4915U	—	—	520	85	105	30	1
	—	—	RNA 6915UU	RNA 6915U	960	85	105	54	1

Notes⁽¹⁾ Minimum allowable value of chamfer dimension r
⁽²⁾ Allowable rotational speed applies to grease lubrication.

Remarks1. The outer ring has an oil groove and an oil hole.
 2. Bearings are provided with prepacked grease. Bearings with a seal on one side are not provided with prepacked grease. Perform proper lubrication for use.

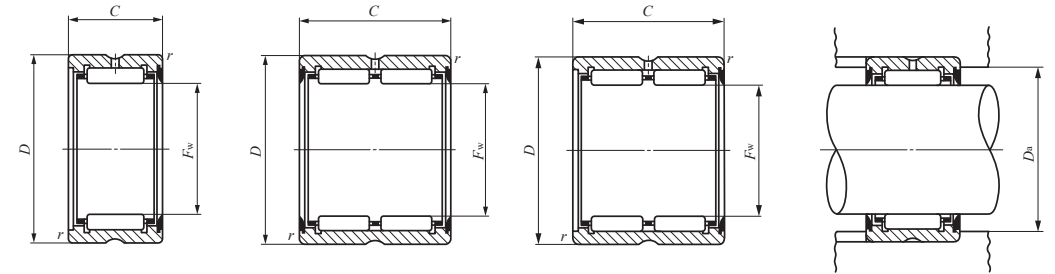
Standard mounting dimension D_a Max. mm	Basic dynamic load rating C N	Basic static load rating C_0 N	Allowable rotational speed ⁽²⁾ min ⁻¹
58	37 200	58 400	4 000
58	63 700	117 000	4 000
61	38 000	60 900	4 000
64	38 900	63 400	3 500
64	66 600	127 000	3 500
66	39 600	66 100	3 500
68	41 300	71 100	3 500
68	70 800	142 000	3 500
71	42 100	73 600	3 000
75	52 200	85 700	3 000
75	89 400	171 000	3 000
77	53 400	89 200	3 000
80	54 500	92 800	3 000
80	93 400	186 000	3 000
83	55 700	96 300	2 500
85	56 800	99 800	2 500
85	97 400	200 000	2 500
90	73 900	133 000	2 500
95	76 900	143 000	2 500
95	124 000	281 000	2 500
100	79 600	153 000	2 000
100	128 000	299 000	2 000

MACHINED TYPE NEEDLE ROLLER BEARINGS

With Seal, Without Inner Ring



RNA49 ... UU



RNA49 ... U

RNA69 ... UU

RNA69 ... U

Shaft dia. 90 – 160mm

Shaft dia. mm	Identification number				Mass (Ref.) g	Boundary dimensions mm			
	With two seals	With one seal	With two seals	With one seal		F_w	D	C	$r_{s \min}^{(1)}$
90	RNA 4916UU	RNA 4916U	—	—	545	90	110	30	1
	—	—	RNA 6916UU	RNA 6916U	1 010	90	110	54	1
95	RNA 49/82UU	RNA 49/82U	—	—	570	95	115	30	1
100	RNA 4917UU	RNA 4917U	—	—	695	100	120	35	1.1
	—	—	RNA 6917UU	RNA 6917U	1 300	100	120	63	1.1
105	RNA 4918UU	RNA 4918U	—	—	730	105	125	35	1.1
	—	—	RNA 6918UU	RNA 6918U	1 360	105	125	63	1.1
110	RNA 4919UU	RNA 4919U	—	—	760	110	130	35	1.1
	—	—	RNA 6919UU	RNA 6919U	1 420	110	130	63	1.1
115	RNA 4920UU	RNA 4920U	—	—	1 200	115	140	40	1.1
125	RNA 4922UU	RNA 4922U	—	—	1 280	125	150	40	1.1
135	RNA 4924UU	RNA 4924U	—	—	1 940	135	165	45	1.1
150	RNA 4926UU	RNA 4926U	—	—	2 360	150	180	50	1.5
160	RNA 4928UU	RNA 4928U	—	—	2 510	160	190	50	1.5

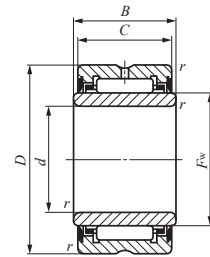
Notes⁽¹⁾ Minimum allowable value of chamfer dimension r
⁽²⁾ Allowable rotational speed applies to grease lubrication.

Remarks1. The outer ring has an oil groove and an oil hole.
 2. Bearings are provided with prepacked grease. Bearings with a seal on one side are not provided with prepacked grease. Perform proper lubrication for use.

Standard mounting dimension D_a Max. mm	Basic dynamic load rating C N	Basic static load rating C_0 N	Allowable rotational speed ⁽²⁾ n min ⁻¹
105	80 700	158 000	2 000
105	132 000	317 000	2 000
110	83 200	168 000	2 000
113.5	103 000	225 000	1 900
113.5	168 000	448 000	1 900
118.5	106 000	238 000	1 800
118.5	172 000	471 000	1 800
123.5	109 000	250 000	1 700
123.5	177 000	493 000	1 700
133.5	134 000	297 000	1 700
143.5	140 000	322 000	1 500
158.5	178 000	410 000	1 400
172	206 000	511 000	1 300
182	214 000	549 000	1 200

MACHINED TYPE NEEDLE ROLLER BEARINGS

With Seal, With Inner Ring



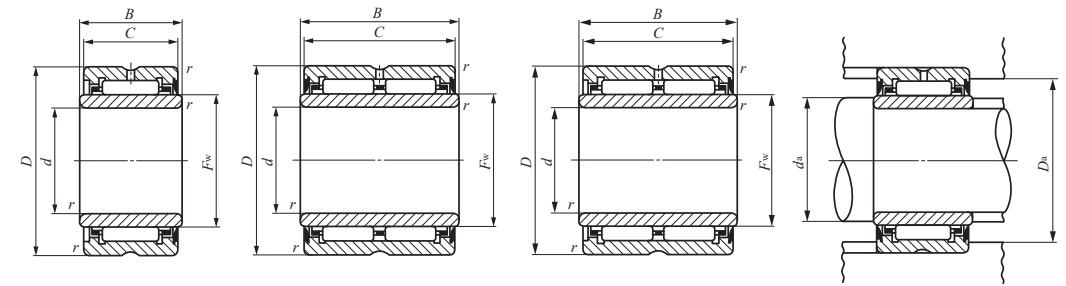
NA49...UU
NA69...UU ($d \leq 30$)

Shaft dia. 10 – 40mm

Shaft dia. mm	Identification number				Mass (Ref.) g	Boundary dimensions mm			
	With two seals	With one seal	With two seals	With one seal		d	D	C	B
10	NA 4900UU	NA 4900U	—	—	24.5	10	22	13	14
12	NA 4901UU	NA 4901U	—	—	27.5	12	24	13	14
	—	—	NA 6901UU	NA 6901U	45.5	12	24	22	23
15	NA 4902UU	NA 4902U	—	—	36	15	28	13	14
	—	—	NA 6902UU	NA 6902U	62.5	15	28	23	24
17	NA 4903UU	NA 4903U	—	—	39.5	17	30	13	14
	—	—	NA 6903UU	NA 6903U	68.5	17	30	23	24
20	NA 4904UU	NA 4904U	—	—	78.5	20	37	17	18
	—	—	NA 6904UU	NA 6904U	137	20	37	30	31
22	NA 49/22UU	NA 49/22U	—	—	87.5	22	39	17	18
	—	—	NA 69/22UU	NA 69/22U	153	22	39	30	31
25	NA 4905UU	NA 4905U	—	—	92.5	25	42	17	18
	—	—	NA 6905UU	NA 6905U	162	25	42	30	31
28	NA 49/28UU	NA 49/28U	—	—	101	28	45	17	18
	—	—	NA 69/28UU	NA 69/28U	177	28	45	30	31
30	NA 4906UU	NA 4906U	—	—	106	30	47	17	18
	—	—	NA 6906UU	NA 6906U	185	30	47	30	31
32	NA 49/32UU	NA 49/32U	—	—	167	32	52	20	21
	—	—	NA 69/32UU	NA 69/32U	300	32	52	36	37
35	NA 4907UU	NA 4907U	—	—	179	35	55	20	21
	—	—	NA 6907UU	NA 6907U	320	35	55	36	37
40	NA 4908UU	NA 4908U	—	—	245	40	62	22	23
	—	—	NA 6908UU	NA 6908U	440	40	62	40	41

Notes⁽¹⁾ Minimum allowable value of chamfer dimension r
⁽²⁾ Allowable rotational speed applies to grease lubrication.

Remarks1. The outer ring has an oil groove and an oil hole.
 2. Bearings are provided with prepacked grease. Bearings with a seal on one side are not provided with prepacked grease. Perform proper lubrication for use.



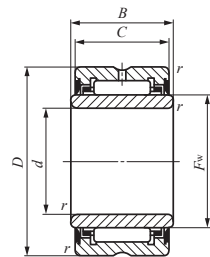
NA49...U
NA69...U ($d \leq 30$)
 NA69...UU
 NA69...U

$r_{s \min}$ ⁽¹⁾	F_w	Standard mounting dimensions mm			Basic dynamic load rating C N	Basic static load rating C_0 N	Allowable rotational speed ⁽²⁾ min ⁻¹	Assembled inner ring
		Min.	Max.	D_a Max.				
0.3	14	12	13	20	8 080	8 490	14 000	LRTZ 101414
0.3	16	14	15	22	8 470	9 320	12 000	LRTZ 121614
		14	15	22	15 500	20 400	12 000	LRTZ 121623
0.3	20	17	19	26	9 570	11 600	9 500	LRTZ 152014
		17	19	26	18 500	27 100	9 500	LRTZ 152024
0.3	22	19	21	28	10 300	13 100	8 500	LRTZ 172214
		19	21	28	19 800	30 600	8 500	LRTZ 172224
0.3	25	22	24	35	18 000	20 500	7 500	LRTZ 202518
		22	24	35	33 000	44 600	7 500	LRTZ 202531
0.3	28	24	27	37	18 300	23 700	7 000	LRTZ 222818
		24	27	37	33 800	52 000	7 000	LRTZ 222831
0.3	30	27	29	40	20 300	25 100	6 500	LRTZ 253018
		27	29	40	39 200	58 700	6 500	LRTZ 253031
0.3	32	30	31	43	21 000	26 800	6 000	LRTZ 283218
		30	31	43	38 900	59 100	6 000	LRTZ 283231
0.3	35	32	34	45	21 500	28 400	5 500	LRTZ 303518
		32	34	45	40 100	63 000	5 500	LRTZ 303531
0.6	40	36	39	48	29 400	44 200	5 000	LRTZ 324021
		36	39	48	50 300	88 300	5 000	LRTZ 324037
0.6	42	39	41	51	30 100	46 300	4 500	LRTZ 354221
		39	41	51	51 600	92 600	4 500	LRTZ 354237
0.6	48	44	47	58	37 200	58 400	4 000	LRTZ 404823
		44	47	58	63 700	117 000	4 000	LRTZ 404841

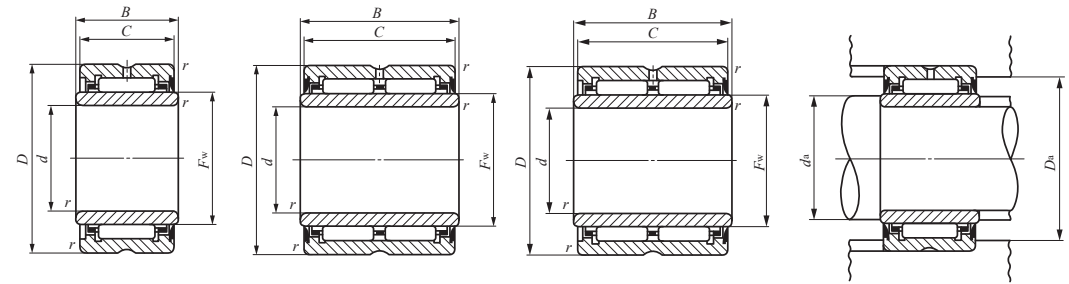
D
 NA
 TAFI
 TRI
 BRI

MACHINED TYPE NEEDLE ROLLER BEARINGS

With Seal, With Inner Ring



NA49...UU



NA49...U

NA69...UU

NA69...U

Shaft dia. 45 – 110mm

Shaft dia. mm	Identification number				Mass (Ref.) g	Boundary dimensions mm			
	With two seals	With one seal	With two seals	With one seal		d	D	C	B
45	NA 4909UU	NA 4909U	—	—	290	45	68	22	23
	—	—	NA 6909UU	NA 6909U	520	45	68	40	41
50	NA 4910UU	NA 4910U	—	—	295	50	72	22	23
	—	—	NA 6910UU	NA 6910U	530	50	72	40	41
55	NA 4911UU	NA 4911U	—	—	415	55	80	25	26
	—	—	NA 6911UU	NA 6911U	730	55	80	45	46
60	NA 4912UU	NA 4912U	—	—	445	60	85	25	26
	—	—	NA 6912UU	NA 6912U	785	60	85	45	46
65	NA 4913UU	NA 4913U	—	—	475	65	90	25	26
	—	—	NA 6913UU	NA 6913U	845	65	90	45	46
70	NA 4914UU	NA 4914U	—	—	770	70	100	30	31
	—	—	NA 6914UU	NA 6914U	1 400	70	100	54	55
75	NA 4915UU	NA 4915U	—	—	815	75	105	30	31
	—	—	NA 6915UU	NA 6915U	1 480	75	105	54	55
80	NA 4916UU	NA 4916U	—	—	860	80	110	30	31
	—	—	NA 6916UU	NA 6916U	1 570	80	110	54	55
85	NA 4917UU	NA 4917U	—	—	1 300	85	120	35	36
	—	—	NA 6917UU	NA 6917U	2 360	85	120	63	64
90	NA 4918UU	NA 4918U	—	—	1 360	90	125	35	36
	—	—	NA 6918UU	NA 6918U	2 480	90	125	63	64
95	NA 4919UU	NA 4919U	—	—	1 420	95	130	35	36
	—	—	NA 6919UU	NA 6919U	2 600	95	130	63	64
100	NA 4920UU	NA 4920U	—	—	1 980	100	140	40	41
110	NA 4922UU	NA 4922U	—	—	2 150	110	150	40	41

Notes⁽¹⁾ Minimum allowable value of chamfer dimension *r*
⁽²⁾ Allowable rotational speed applies to grease lubrication.

Remarks1. The outer ring has an oil groove and an oil hole.
 2. Bearings are provided with prepacked grease. Bearings with a seal on one side are not provided with prepacked grease. Perform proper lubrication for use.

$r_{s \min}^{(1)}$	F_w	Standard mounting dimensions mm			Basic dynamic load rating <i>C</i> N	Basic static load rating <i>C</i> ₀ N	Allowable rotational speed ⁽²⁾ min ⁻¹	Assembled inner ring
		Min.	Max.	<i>D</i> _a Max.				
0.6	52	49	51	64	38 900	63 400	3 500	LRTZ 455223
		49	51	64	66 600	127 000	3 500	LRTZ 455241
0.6	58	54	57	68	41 300	71 100	3 500	LRTZ 505823
		54	57	68	70 800	142 000	3 500	LRTZ 505841
1	63	60	61	75	52 200	85 700	3 000	LRTZ 556326
		60	61	75	89 400	171 000	3 000	LRTZ 556346
1	68	65	66	80	54 500	92 800	3 000	LRTZ 606826
		65	66	80	93 400	186 000	3 000	LRTZ 606846
1	72	70	70.5	85	56 800	99 800	2 500	LRTZ 657226
		70	70.5	85	97 400	200 000	2 500	LRTZ 657246
1	80	75	78	95	76 900	143 000	2 500	LRTZ 708031
		75	78	95	124 000	281 000	2 500	LRTZ 708055
1	85	80	83	100	79 600	153 000	2 000	LRTZ 758531
		80	83	100	128 000	299 000	2 000	LRTZ 758555
1	90	85	88	105	80 700	158 000	2 000	LRTZ 809031
		85	88	105	132 000	317 000	2 000	LRTZ 809055
1.1	100	91.5	98	113.5	103 000	225 000	1 900	LRTZ 8510036
		91.5	98	113.5	168 000	448 000	1 900	LRTZ 8510064
1.1	105	96.5	103	118.5	106 000	238 000	1 800	LRTZ 9010536
		96.5	103	118.5	172 000	471 000	1 800	LRTZ 9010564
1.1	110	101.5	108	123.5	109 000	250 000	1 700	LRTZ 9511036
		101.5	108	123.5	177 000	493 000	1 700	LRTZ 9511064
1.1	115	106.5	113	133.5	134 000	297 000	1 700	LRTZ 10011541
		106.5	113	133.5	140 000	322 000	1 500	LRTZ 11012541

D
NA
TAFI
TRI
BRI

MACHINED TYPE NEEDLE ROLLER BEARINGS

With Seal, With Inner Ring

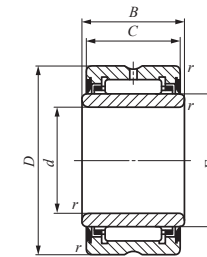


Shaft dia. 120 – 140mm

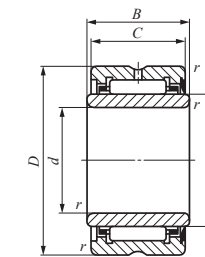
Shaft dia. mm	Identification number				Mass (Ref.) g	Boundary dimensions mm			
	With two seals	With one seal	With two seals	With one seal		<i>d</i>	<i>D</i>	<i>C</i>	<i>B</i>
120	NA 4924UU	NA 4924U	—	—	2 990	120	165	45	46
130	NA 4926UU	NA 4926U	—	—	4 080	130	180	50	51
140	NA 4928UU	NA 4928U	—	—	4 340	140	190	50	51

Notes⁽¹⁾ Minimum allowable value of chamfer dimension *r*
⁽²⁾ Allowable rotational speed applies to grease lubrication.

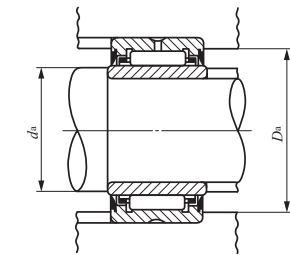
Remarks1. The outer ring has an oil groove and an oil hole.
 2. Bearings are provided with prepacked grease. Bearings with a seal on one side are not provided with prepacked grease. Perform proper lubrication for use.



NA49...UU



NA49...U



<i>r</i> _{s min} ⁽¹⁾	<i>F</i> _w	Standard mounting dimensions mm			Basic dynamic load rating <i>C</i> N	Basic static load rating <i>C</i> ₀ N	Allowable rotational speed ⁽²⁾ min ⁻¹	Assembled inner ring
		<i>d</i> _a Min.	<i>d</i> _a Max.	<i>D</i> _a Max.				
1.1	135	126.5	133	158.5	178 000	410 000	1 400	LRTZ 12013546
1.5	150	138	148	172	206 000	511 000	1 300	LRTZ 13015051
1.5	160	148	158	182	214 000	549 000	1 200	LRTZ 14016051

MACHINED TYPE NEEDLE ROLLER BEARINGS

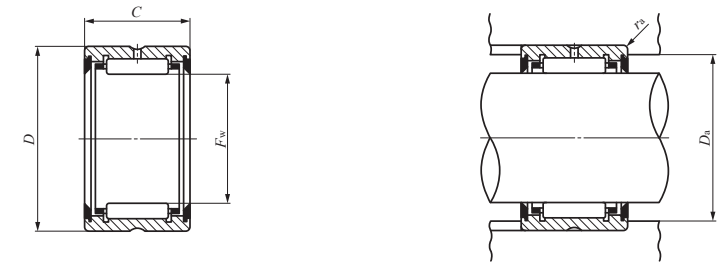
With Seal, Without Inner Ring, Inch Series



Shaft dia. 15.875 — 50.800mm

Shaft dia. mm (inch)	Identification number With two seals	Mass (Ref.) g	Boundary dimensions mm(inch)			Standard mounting dimensions mm	
			F_w	D	C	D_a Max.	$r_{as\ max}^{(1)}$
15.875 (5/8)	BR 101816 UU	54	15.875 (5/8)	28.575 (1 1/8)	25.400 (1)	24.5	0.6
19.050 (3/4)	BR 122016 UU	68	19.050 (3/4)	31.750 (1 1/4)	25.400 (1)	26.5	1.0
22.225 (7/8)	BR 142216 UU	76	22.225 (7/8)	34.925 (1 3/8)	25.400 (1)	29.7	1.0
25.400 (1)	BR 162416 UU	83	25.400 (1)	38.100 (1 1/2)	25.400 (1)	32.9	1.0
28.575 (1 1/8)	BR 182620 UU	115	28.575 (1 1/8)	41.275 (1 5/8)	31.750 (1 1/4)	36.0	1.0
31.750 (1 1/4)	BR 202820 UU	124	31.750 (1 1/4)	44.450 (1 3/4)	31.750 (1 1/4)	39.2	1.0
34.925 (1 3/8)	BR 223020 UU	134	34.925 (1 3/8)	47.625 (1 7/8)	31.750 (1 1/4)	42.4	1.0
38.100 (1 1/2)	BR 243320 UU	168	38.100 (1 1/2)	52.388 (2 1/16)	31.750 (1 1/4)	45.1	1.5
41.275 (1 5/8)	BR 263520 UU	179	41.275 (1 5/8)	55.562 (2 3/16)	31.750 (1 1/4)	48.3	1.5
44.450 (1 3/4)	BR 283720 UU	193	44.450 (1 3/4)	58.738 (2 5/16)	31.750 (1 1/4)	51.5	1.5
47.625 (1 7/8)	BR 303920 UU	202	47.625 (1 7/8)	61.912 (2 7/16)	31.750 (1 1/4)	54.7	1.5
50.800 (2)	BR 324120 UU	216	50.800 (2)	65.088 (2 9/16)	31.750 (1 1/4)	57.8	1.5

- Notes⁽¹⁾ Maximum permissible corner radius of the housing
⁽²⁾ Allowable rotational speed applies to grease lubrication.
 Remarks1. The outer ring has an oil groove and an oil hole.
 2. Bearings are provided with prepacked grease.
 3. If one side sealed type are needed, please contact IKO.



BR... UU

Basic dynamic load rating C N	Basic static load rating C_0 N	Allowable rotational speed ⁽²⁾ min ⁻¹
18 300	20 000	12 000
20 700	24 400	10 000
21 600	26 900	9 000
23 600	31 300	8 000
34 900	49 900	7 000
36 000	53 500	6 500
38 500	60 000	5 500
43 700	66 900	5 500
44 800	70 900	4 500
47 500	78 200	4 500
48 500	82 100	4 000
51 000	89 400	4 000

MACHINED TYPE NEEDLE ROLLER BEARINGS

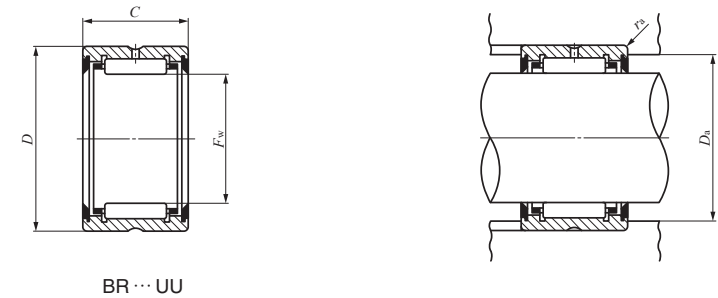
With Seal, Without Inner Ring, Inch Series



Shaft dia. 57.150 — 95.250mm

Shaft dia. mm (inch)	Identification number With two seals	Mass (Ref.) g	Boundary dimensions mm(inch)			Standard mounting dimensions mm	
			F_w	D	C	D_a Max.	$r_{as\ max}^{(1)}$
57.150 (2 1/4)	BR 364828 UU	459	57.150 (2 1/4)	76.200 (3)	44.450 (1 3/4)	69.0	1.5
63.500 (2 1/2)	BR 405228 UU	499	63.500 (2 1/2)	82.550 (3 1/4)	44.450 (1 3/4)	74.3	2.0
69.850 (2 3/4)	BR 445628 UU	540	69.850 (2 3/4)	88.900 (3 1/2)	44.450 (1 3/4)	80.7	2.0
76.200 (3)	BR 486028 UU	585	76.200 (3)	95.250 (3 3/4)	44.450 (1 3/4)	87.0	2.0
82.550 (3 1/4)	BR 526828 UU	891	82.550 (3 1/4)	107.950 (4 1/4)	44.450 (1 3/4)	99.7	2.0
88.900 (3 1/2)	BR 567232 UU	1 098	88.900 (3 1/2)	114.300 (4 1/2)	50.800 (2)	106.1	2.0
95.250 (3 3/4)	BR 607632 UU	1 161	95.250 (3 3/4)	120.650 (4 3/4)	50.800 (2)	111.4	2.5

Notes⁽¹⁾ Maximum permissible corner radius of the housing
⁽²⁾ Allowable rotational speed applies to grease lubrication.
 Remarks1. The outer ring has an oil groove and an oil hole.
 2. Bearings are provided with prepacked grease.
 3. If one side sealed type are needed, please contact IKO.



BR ... UU

Basic dynamic load rating C N	Basic static load rating C_0 N	Allowable rotational speed ⁽²⁾ min ⁻¹
90 300	158 000	3 500
94 600	174 000	3 000
98 700	189 000	2 500
105 000	211 000	2 500
109 000	227 000	2 500
142 000	265 000	2 000
148 000	287 000	2 000

D

NA
TAFI
TRI
BRI

MACHINED TYPE NEEDLE ROLLER BEARINGS

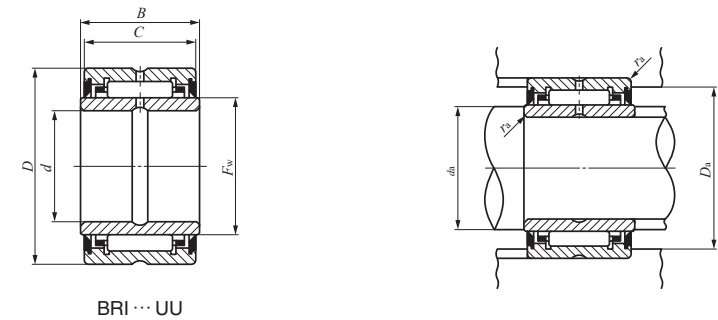
With Seal, With Inner Ring, Inch Series



Shaft dia. 9.525 – 44.450mm

Shaft dia. mm (inch)	Identification number With two seals	Mass (Ref.) g	Boundary dimensions mm(inch)					F_w
			d	D	C	B		
9.525 ($\frac{3}{8}$)	BRI 61816 UU	79	9.525 ($\frac{3}{8}$)	28.575 (1 $\frac{1}{8}$)	25.400 (1)	25.650	15.875 ($\frac{5}{8}$)	
12.700 ($\frac{1}{2}$)	BRI 82016 UU	99	12.700 ($\frac{1}{2}$)	31.750 (1 $\frac{1}{4}$)	25.400 (1)	25.650	19.050 ($\frac{3}{4}$)	
15.875 ($\frac{5}{8}$)	BRI 102216 UU	113.5	15.875 ($\frac{5}{8}$)	34.925 (1 $\frac{3}{8}$)	25.400 (1)	25.650	22.225 ($\frac{7}{8}$)	
19.050 ($\frac{3}{4}$)	BRI 122416 UU	127	19.050 ($\frac{3}{4}$)	38.100 (1 $\frac{1}{2}$)	25.400 (1)	25.650	25.400 (1)	
22.225 ($\frac{7}{8}$)	BRI 142620 UU	177	22.225 ($\frac{7}{8}$)	41.275 (1 $\frac{5}{8}$)	31.750 (1 $\frac{1}{4}$)	32.000	28.575 (1 $\frac{1}{8}$)	
25.400 (1)	BRI 162820 UU	196	25.400 (1)	44.450 (1 $\frac{3}{4}$)	31.750 (1 $\frac{1}{4}$)	32.000	31.750 (1 $\frac{1}{4}$)	
28.575 (1 $\frac{1}{8}$)	BRI 183020 UU	211	28.575 (1 $\frac{1}{8}$)	47.625 (1 $\frac{7}{8}$)	31.750 (1 $\frac{1}{4}$)	32.000	34.925 (1 $\frac{3}{8}$)	
31.750 (1 $\frac{1}{4}$)	BRI 203320 UU	254	31.750 (1 $\frac{1}{4}$)	52.388 (2 $\frac{1}{16}$)	31.750 (1 $\frac{1}{4}$)	32.000	38.100 (1 $\frac{1}{2}$)	
34.925 (1 $\frac{3}{8}$)	BRI 223520 UU	275	34.925 (1 $\frac{3}{8}$)	55.562 (2 $\frac{3}{16}$)	31.750 (1 $\frac{1}{4}$)	32.000	41.275 (1 $\frac{5}{8}$)	
38.100 (1 $\frac{1}{2}$)	BRI 243720 UU BRI 243920 UU	293 362	38.100 (1 $\frac{1}{2}$) 38.100 (1 $\frac{1}{2}$)	58.738 (2 $\frac{5}{16}$) 61.912 (2 $\frac{7}{16}$)	31.750 (1 $\frac{1}{4}$) 31.750 (1 $\frac{1}{4}$)	32.000	44.450 (1 $\frac{3}{4}$) 47.625 (1 $\frac{7}{8}$)	
41.275 (1 $\frac{5}{8}$)	BRI 264120 UU	386	41.275 (1 $\frac{5}{8}$)	65.088 (2 $\frac{9}{16}$)	31.750 (1 $\frac{1}{4}$)	32.000	50.800 (2)	
44.450 (1 $\frac{3}{4}$)	BRI 284828 UU	804	44.450 (1 $\frac{3}{4}$)	76.200 (3)	44.450 (1 $\frac{3}{4}$)	44.700	57.150 (2 $\frac{1}{4}$)	

- Notes⁽¹⁾ Maximum permissible corner radius of the shaft or housing
⁽²⁾ Allowable rotational speed applies to grease lubrication.
 Remarks1. The inner ring and the outer ring each have an oil groove and an oil hole.
 2. Bearings are provided with prepacked grease.
 3. If one side sealed type are needed, please contact IKO.



Standard mounting dimensions mm				Basic dynamic load rating C N	Basic static load rating C_0 N	Allowable rotational speed ⁽²⁾ min ⁻¹	Assembled inner ring
d_a Min.	d_a Max.	D_a Max.	$r_{as\ max}^{(1)}$				
14	14.5	24.5	0.6	18 300	20 000	12 000	LRBZ 61016 B
17.5	18	26.5	0.6	20 700	24 400	10 000	LRBZ 81216 B
21	21.2	29.7	0.6	21 600	26 900	9 000	LRBZ 101416 B
24	24.4	32.9	0.6	23 600	31 300	8 000	LRBZ 121616 B
27	27.5	36.0	0.6	34 900	49 900	7 000	LRBZ 141820 B
30.5	30.7	39.2	0.6	36 000	53 500	6 500	LRBZ 162020 B
33.5	33.9	42.4	0.6	38 500	60 000	5 500	LRBZ 182220 B
37	37.1	45.1	0.6	43 700	66 900	5 500	LRBZ 202420 B
40.2	40.2	48.3	0.6	44 800	70 900	4 500	LRBZ 222620 B
43.3	43.4	51.5	0.6	47 500	78 200	4 500	LRBZ 242820 B
43.3	45	54.7	1	48 500	82 100	4 000	LRBZ 243020 B
48	49	57.8	1	51 000	89 400	4 000	LRBZ 263220 B
52.5	55	69.0	1.5	90 300	158 000	3 500	LRBZ 283628 B

MACHINED TYPE NEEDLE ROLLER BEARINGS

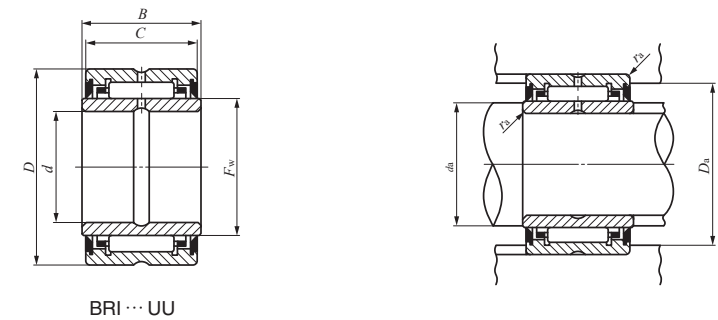
With Seal, With Inner Ring, Inch Series



Shaft dia. 50.800 — 82.550mm

Shaft dia. mm (inch)	Identification number With two seals	Mass (Ref.) g	Boundary dimensions mm(inch)				
			<i>d</i>	<i>D</i>	<i>C</i>	<i>B</i>	<i>F_w</i>
50.800 (2)	BRI 325228 UU	889	50.800 (2)	82.550 (3 1/4)	44.450 (1 3/4)	44.700	63.500 (2 1/2)
57.150 (2 1/4)	BRI 365628 UU	980	57.150 (2 1/4)	88.900 (3 1/2)	44.450 (1 3/4)	44.700	69.850 (2 3/4)
63.500 (2 1/2)	BRI 406028 UU	1 065	63.500 (2 1/2)	95.250 (3 3/4)	44.450 (1 3/4)	44.700	76.200 (3)
69.850 (2 3/4)	BRI 446828 UU	1 421	69.850 (2 3/4)	107.950 (4 1/4)	44.450 (1 3/4)	44.700	82.550 (3 1/4)
76.200 (3)	BRI 487232 UU	1 738	76.200 (3)	114.300 (4 1/2)	50.800 (2)	51.050	88.900 (3 1/2)
82.550 (3 1/4)	BRI 527632 UU	1 851	82.550 (3 1/4)	120.650 (4 3/4)	50.800 (2)	51.050	95.250 (3 3/4)

- Notes⁽¹⁾ Maximum permissible corner radius of the shaft or housing
⁽²⁾ Allowable rotational speed applies to grease lubrication.
 Remarks1. The inner ring and the outer ring each have an oil groove and an oil hole.
 2. Bearings are provided with prepacked grease.
 3. If one side sealed type are needed, please contact IKO.

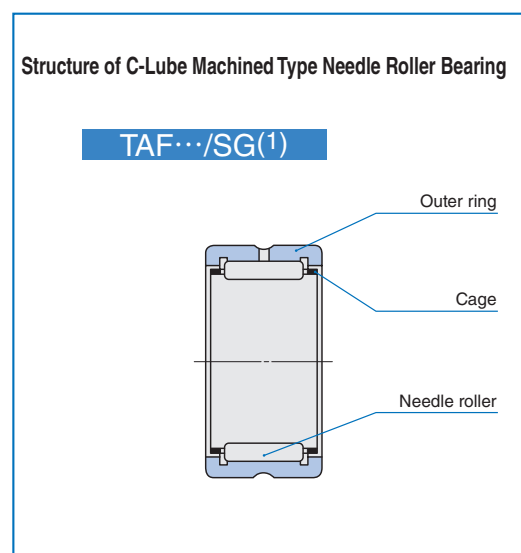


Standard mounting dimensions mm				Basic dynamic load rating <i>C</i> N	Basic static load rating <i>C₀</i> N	Allowable rotational speed ⁽²⁾ min ⁻¹	Assembled inner ring
<i>d_a</i> Min.	<i>d_a</i> Max.	<i>D_a</i> Max.	<i>r_{as max}</i> ⁽¹⁾				
58	61	74.3	1.5	94 600	174 000	3 000	LRBZ 324028 B
65	67	80.7	1.5	98 700	189 000	2 500	LRBZ 364428 B
71	73	87.0	1.5	105 000	211 000	2 500	LRBZ 404828 B
77	79	99.7	1.5	109 000	227 000	2 500	LRBZ 445228 B
83.5	86	106.1	1.5	142 000	265 000	2 000	LRBZ 485632 B
91	93	111.4	1.5	148 000	287 000	2 000	LRBZ 526032 B

C-LUBE MACHINED TYPE NEEDLE ROLLER BEARINGS

Structure and features

C-Lube Machined Type Needle Roller Bearing is a bearing that is lubricated with a newly developed thermosetting solid-type lubricant. A large amount of lubricating oil and fine particles of ultra high molecular weight polyolefin resin are solidified by heat treatment to fill the inner space of the bearing. As the bearing rotates, the lubricating oil oozes out onto the raceway in proper quantities, maintaining the lubrication performance for a long period of time. C-Lube Machined Type Needle Roller Bearings are bearings with a low sectional height and large load ratings. The outer ring has high rigidity and can easily be used even for light alloy housings.



Note(1) Thermosetting solid-type lubricant fills inner space of the bearing.

Type

C-Lube Machined Type Needle Roller Bearing is available in type shown in Table 1.

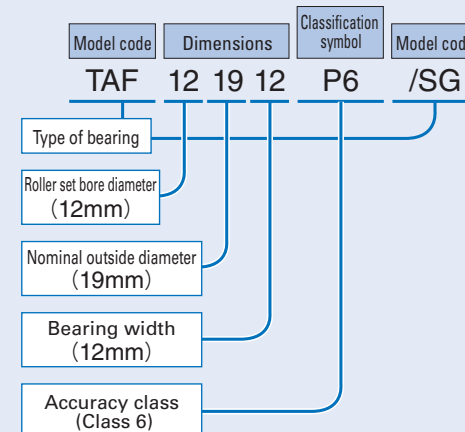
Table 1 Type of bearing

Series	Type	Needle bearing with cage
		Without inner ring
Metric series	For light duty	TAF.../SG

Identification number

The identification number of C-Lube Machined Type Needle Roller Bearing consists of model code, dimensions and classification symbol. Example is shown below.

Example of identification number



Accuracy

C-Lube Machined Type Needle Roller Bearings are manufactured based on JIS (See page A31.). The tolerances for the smallest single roller set bore diameter of bearings without inner ring are based on Table 14 on page A33.

Fit

The recommended fits for C-Lube Machined Type Needle Roller Bearings are shown in Tables 21 to 23 on pages A41 and A42.

Allowable Rotational Speed

The allowable rotational speed of C-Lube Machined Type Needle Roller Bearing is affected by mounting and operating conditions. The reference $d_m n$ value (1) is 20,000.

Note(1) $d_m n$ value = $\{(Bore\ diameter\ of\ bearing\ [mm] + Outside\ diameter\ of\ bearing\ [mm])/2\} \times rotational\ speed\ [min^{-1}]$

Lubrication

As the internal space of C-Lube Machined Type Needle Roller Bearing is filled with thermosetting solid-type lubricant C-Lube, regreasing is not possible due to the structure.

Oil hole

Table 2 shows the number of oil holes on the outer ring.

Table 2 Number of oil holes of outer ring

Nominal roller set bore diameter F_w mm	Number of hole holes of outer ring
$F_w \leq 26$	0
$26 < F_w$	1

Remark If there is oil hole on the outer ring, care must be exercised not to let oil holes within the load range.

Mounting

- Mounting dimensions for C-Lube Machined Type Needle Roller Bearings are shown in the table of dimensions.
- When mounting, pay special attention to avoid locating the oil hole within the loading zone. This may lead to a short bearing life.

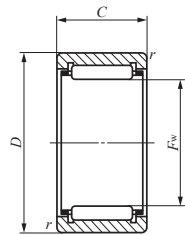
Precaution for Use

- Do not wash C-Lube Machined Type Needle Roller Bearing with organic solvent and/or white kerosene, which have the ability of removing fat nor leave them in contact with the above agents.
- To ensure normal rotation of the C-Lube Machined Type Needle Roller Bearing, apply a load of 1% or over of the dynamic load rating at use.
- The operating temperature range is $-15 \sim +80^\circ C$. For continuous operation, the recommended operating temperature is $+60^\circ C$ or less.
- When using two or more C-Lube Machined Type Needle Roller Bearings adjacent to each other on the same shaft, it is necessary to obtain an even load distribution. On request, a set of bearings is available, in which bearings are matched to obtain an even load distribution.

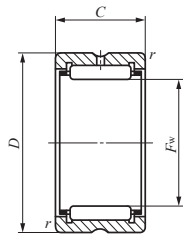
Further, C-Lube Machined Type Needle Roller Bearing for food machinery is also available. If needed, please contact IKO.

C-LUBE MACHINED TYPE NEEDLE ROLLER BEARINGS

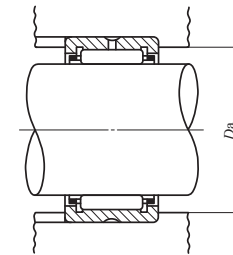
Without Inner Ring



TAF .../SG
 $F_w \leq 26$



TAF .../SG
 $F_w > 26$



Shaft dia. 10–45mm

Shaft dia.	Identification number	Mass (Ref.) g	Boundary dimensions mm				Standard mounting dimension D_a Max. mm	Basic dynamic load rating C N	Basic static load rating C_0 N
			F_w	D	C	$r_s \min^{(1)}$			
10	TAF 101712/SG	11	10	17	12	0.2	15.4	5 880	5 970
	TAF 101716/SG	14.7	10	17	16	0.2	15.4	8 230	9 190
12	TAF 121912/SG	12.5	12	19	12	0.3	17	6 610	7 260
	TAF 121916/SG	16.8	12	19	16	0.3	17	9 250	11 200
14	TAF 142216/SG	22	14	22	16	0.3	20	11 700	13 700
	TAF 142220/SG	27.5	14	22	20	0.3	20	14 800	18 600
15	TAF 152316/SG	23.5	15	23	16	0.3	21	12 300	14 900
	TAF 152320/SG	29	15	23	20	0.3	21	15 600	20 200
16	TAF 162416/SG	24	16	24	16	0.3	22	12 300	15 100
	TAF 162420/SG	30	16	24	20	0.3	22	15 500	20 400
18	TAF 182616/SG	26.5	18	26	16	0.3	24	13 400	17 500
	TAF 182620/SG	33	18	26	20	0.3	24	17 000	23 600
19	TAF 192716/SG	28	19	27	16	0.3	25	14 000	18 700
	TAF 192720/SG	35.5	19	27	20	0.3	25	17 700	25 300
20	TAF 202816/SG	28.5	20	28	16	0.3	26	13 900	18 800
	TAF 202820/SG	37	20	28	20	0.3	26	17 600	25 400
21	TAF 212916/SG	30	21	29	16	0.3	27	14 400	20 000
	TAF 212920/SG	37.5	21	29	20	0.3	27	18 200	27 100
22	TAF 223016/SG	31	22	30	16	0.3	28	14 900	21 200
	TAF 223020/SG	39	22	30	20	0.3	28	18 900	28 700
24	TAF 243216/SG	33	24	32	16	0.3	30	15 300	22 500
	TAF 243220/SG	42	24	32	20	0.3	30	19 400	30 500
25	TAF 253316/SG	35	25	33	16	0.3	31	15 800	23 700
	TAF 253320/SG	43.5	25	33	20	0.3	31	20 000	32 100

Note(1) Minimum allowable value of chamfer dimension r_s .

Remarks1. Models with a nominal roller set bore diameter F_w of 26mm or less are provided without oil holes, other models are provided with one oil hole and oil groove.

2. This bearing can not be re-lubricated as thermosetting solid-type lubricant C-Lube fills inner space of the bearing.

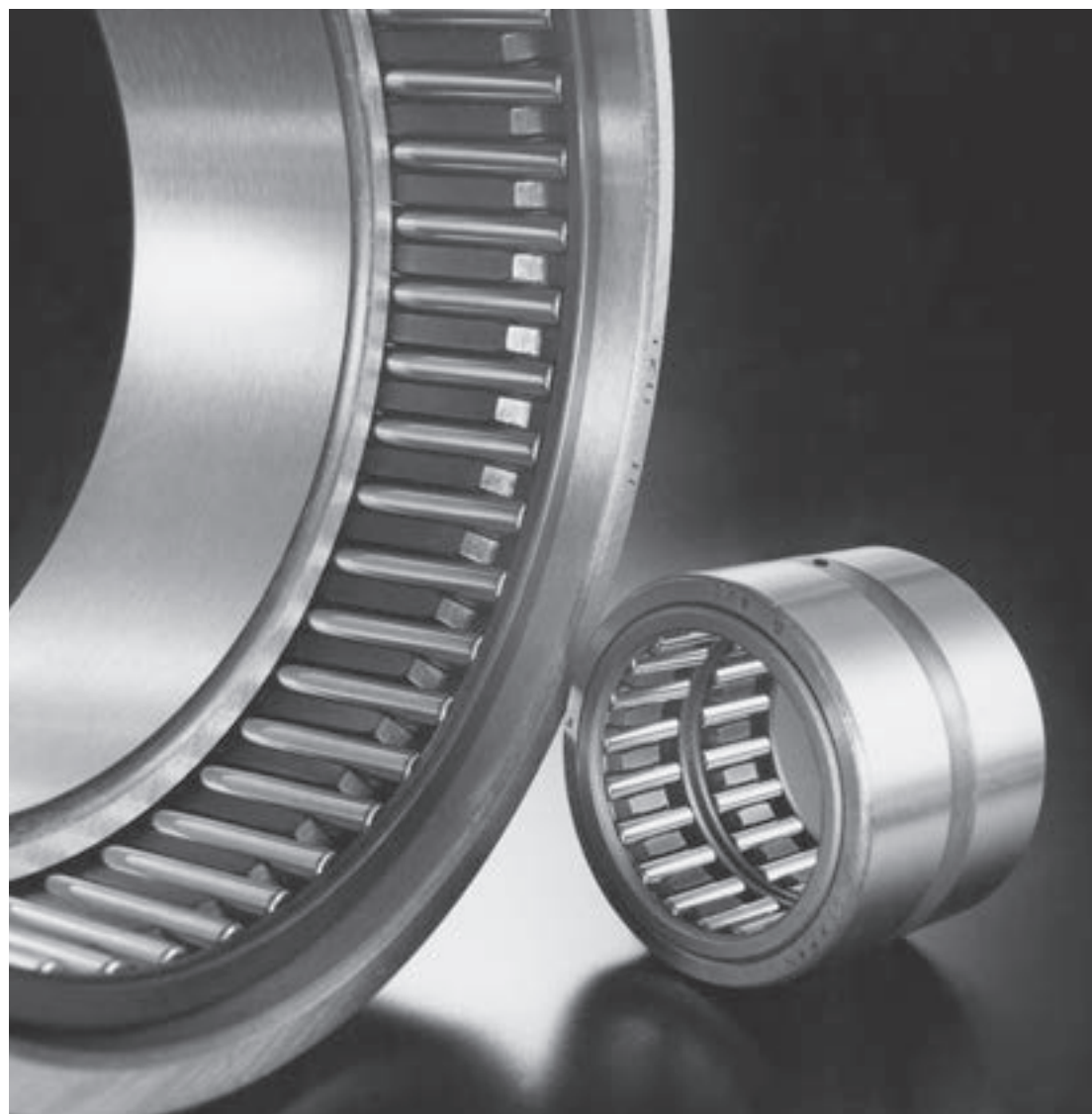
Shaft dia.	Identification number	Mass (Ref.) g	Boundary dimensions mm				Standard mounting dimension D_a Max. mm	Basic dynamic load rating C N	Basic static load rating C_0 N
			F_w	D	C	$r_s \min^{(1)}$			
29	TAF 293820/SG	59	29	38	20	0.3	36	21 600	37 200
	TAF 293830/SG	88	29	38	30	0.3	36	30 900	59 100
30	TAF 304020/SG	67	30	40	20	0.3	38	25 100	40 100
	TAF 304030/SG	101	30	40	30	0.3	38	36 000	63 900
35	TAF 354520/SG	76.5	35	45	20	0.3	43	26 900	46 200
	TAF 354530/SG	116.5	35	45	30	0.3	43	38 600	73 600
40	TAF 405020/SG	86	40	50	20	0.3	48	29 400	54 100
	TAF 405030/SG	130	40	50	30	0.3	48	42 300	86 200
45	TAF 455520/SG	95.5	45	55	20	0.3	53	31 000	60 200
	TAF 455530/SG	144	45	55	30	0.3	53	44 600	95 800

D

TAF.../SG

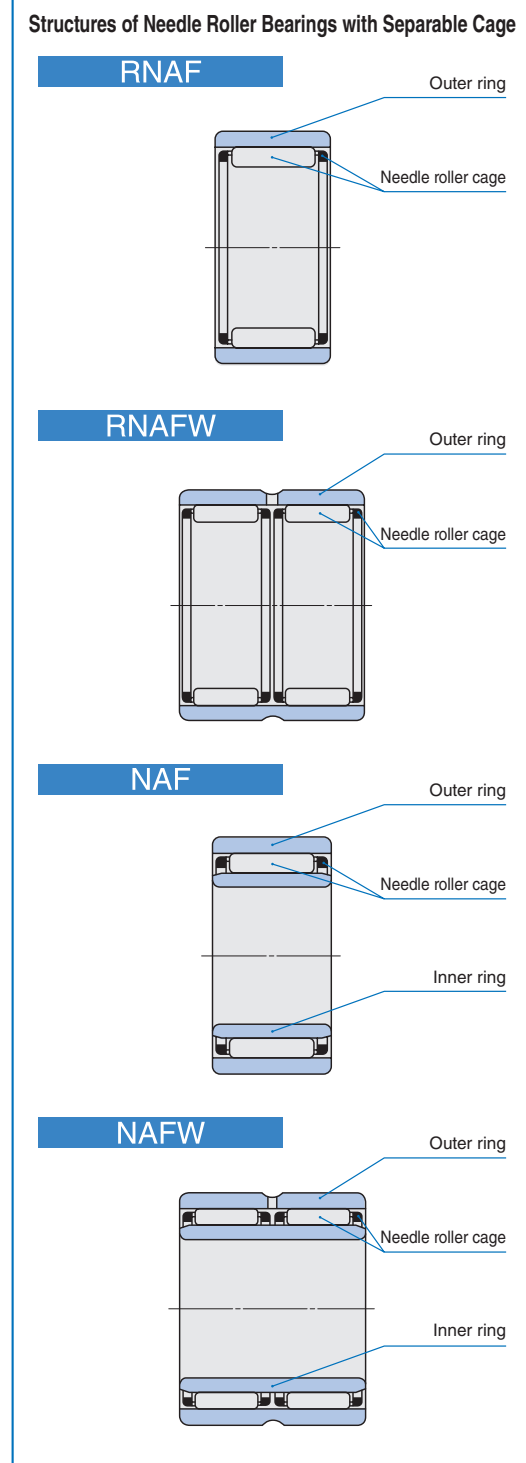
NEEDLE ROLLER BEARINGS WITH SEPARABLE CAGE

- Needle Roller Bearings with Separable Cage - Without Inner Ring
- Needle Roller Bearings with Separable Cage - With Inner Ring



Structure and Features

In IKO Needle Roller Bearings with Separable Cage, the inner ring, outer ring and IKO Needle Roller Cage are combined, and they can be separated easily. This type has a simple structure with high accuracy. In addition, the radial clearance can be freely chosen by selecting and combining these component parts. As Needle Roller Cages are used, these bearings have excellent rotational performance. These bearings are most suitable for mass-production high accuracy products such as machine tools, textile machinery, and printing machines.



Types

Needle Roller Bearings with Separable Cage are available in the types shown in Table 1.

Table 1 Type of bearing

Type	Single-row		Double-row	
	Without inner ring	With inner ring	Without inner ring	With inner ring
Model code	RNAF	NAF	RNAFW	NAFW

Needle Roller Bearings with Separable Cage - Without Inner Ring

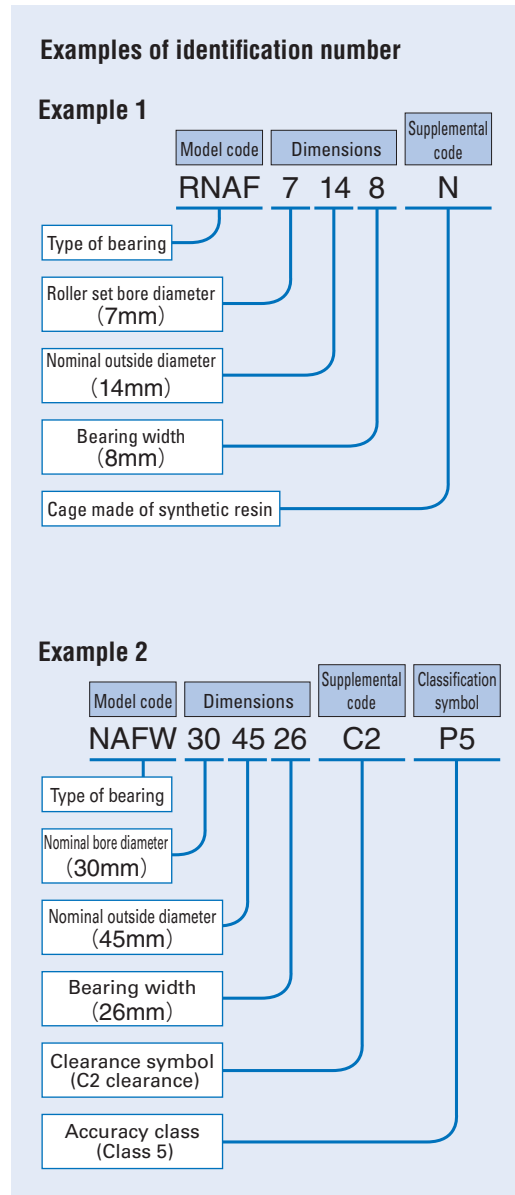
The single-row as well as the double-row types are available with the same sectional height, and either of them can be selected according to load conditions. As shown in the section, "Design of shaft and housing" on page A44, any desired radial internal clearance can be selected by combining a shaft which is heat-treated and finished by grinding.

Needle Roller Bearings with Separable Cage - With Inner Ring

These bearings are made to the CN clearance shown in Table 19 on page A37. When especially high accuracy is required, it is possible to supply semi-finished inner rings which have a finishing allowance on their outside diameter so that they can be ground after being press-fitted to shafts.

Identification Number

The identification number of Needle Roller Bearings with Separable Cage consists of a model code, dimensions, any supplemental codes and a classification symbol. The arrangement examples are as follows.



Accuracy

Needle Roller Bearings with Separable Cage are manufactured to the accuracy based on JIS (See page A31.). Tolerances for the smallest single roller set bore diameter of bearings without inner ring are based on Table 14 on page A33.

Clearance

Radial internal clearances of Needle Roller Bearings with Separable Cage are made to the CN clearance shown in Table 18 on page A37.

Fit

Recommended fits for Needle Roller Bearings with Separable Cage are shown in Tables 21 to 23 on pages A41 and A42.

Lubrication

Needle Roller Bearings with Separable Cage are not provided with prepacked grease. Perform proper lubrication for use. Using them without lubrication will increase the wear of the rolling contact surfaces and shorten their lives.

Oil Hole

The double-row type outer rings have both an oil hole and an oil groove, but the single-row type outer rings do not. When outer rings with an oil hole are required, attach "-OH" before the clearance symbol in the identification number, and when outer rings with both an oil hole and an oil groove are required, attach "-OG" to the same position.

Example: NAF 203517 - OH C2 P6

When outer rings with multiple oil holes or inner rings with oil hole(s) are required, please contact IKO.

Operating temperature range

For synthetic resin cages, "N" is added at the end of the identification number. The operating temperature range for Needle Roller Bearings with Separable Cage is -20 ~ +120°C. However, the maximum allowable temperature for synthetic resin cages is +110°C, and when they are continuously operated, it is +100°C.

Mounting

Mounting examples of Needle Roller Bearings with Separable Cage are shown in Fig.1.

When mounting Needle Roller Bearings with Separable Cage, it is necessary to locate the needle cage axially. The needle cage is guided by shoulders of the shaft and housing or by side plates, and their guide surfaces must be heat-treated and finished by grinding at right angles to the shaft central axis. Dimensions related to mounting are shown in the table of dimensions.

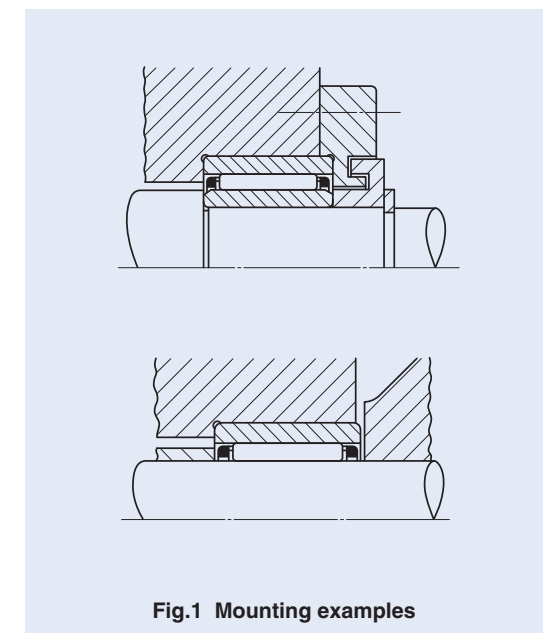


Fig.1 Mounting examples

NEEDLE ROLLER BEARINGS WITH SEPARABLE CAGE

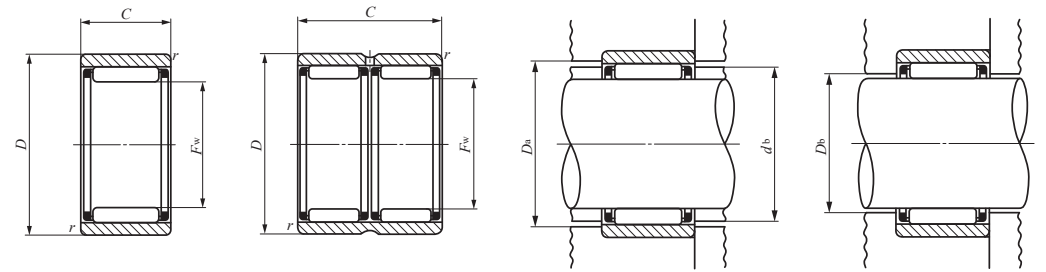
Without Inner Ring



Shaft dia. 5 – 18mm

Shaft dia. mm	Identification number	Mass (Ref.) g	Boundary dimensions mm				Standard mounting dimensions mm			Basic dynamic load rating <i>C</i> N	Basic static load rating <i>C</i> ₀ N
			<i>F</i> _w	<i>D</i>	<i>C</i>	<i>r</i> _{s min} ⁽¹⁾	<i>d</i> _b	<i>D</i> _a Max.	<i>D</i> _b		
5	RNAF 5108N	2.8	5	10	8	0.2	6.7	8.4	5.4	2 420	1 950
6	RNAF 6138N	5.5	6	13	8	0.3	8.4	11	6.4	2 700	2 320
7	RNAF 7148N	6.1	7	14	8	0.3	9.4	12	7.4	2 960	2 690
8	RNAF 81510	8.2	8	15	10	0.3	10.4	13	8.4	3 630	3 600
	RNAFW 81620	20.5	8	16	20	0.3	10.8	14	8.4	6 220	7 200
10	RNAF 101710	9.6	10	17	10	0.3	12.4	15	10.4	4 160	4 550
	RNAF 102012	18.7	10	20	12	0.3	13.5	18	10.4	5 940	6 000
12	RNAF 122212	19.5	12	22	12	0.3	15.5	20	12.4	9 030	8 460
14	RNAF 142213	18.7	14	22	13	0.3	17.6	20	14.6	7 860	9 410
	RNAFW 142220	28.5	14	22	20	0.3	17.6	20	14.6	10 800	14 200
	RNAF 142612	29	14	26	12	0.3	19.4	24	14.6	9 790	9 680
15	RNAF 152313	19.7	15	23	13	0.3	18.6	21	15.6	8 250	10 200
	RNAFW 152320	30.5	15	23	20	0.3	18.6	21	15.6	11 400	15 400
16	RNAF 162413	21	16	24	13	0.3	19.6	22	16.6	8 620	11 000
	RNAFW 162420	32	16	24	20	0.3	19.6	22	16.6	11 900	16 700
	RNAF 162812	31.5	16	28	12	0.3	21.4	26	16.6	10 500	10 900
17	RNAF 172513	22	17	25	13	0.3	20.6	23	17.6	8 980	11 800
	RNAFW 172520	33.5	17	25	20	0.3	20.6	23	17.6	12 400	17 900
18	RNAF 182613	23	18	26	13	0.3	21.6	24	18.6	9 330	12 700
	RNAFW 182620	35	18	26	20	0.3	21.6	24	18.6	12 900	19 100
	RNAF 183012	34.5	18	30	12	0.3	23.4	28	18.6	11 800	13 100
	RNAFW 183024	69.5	18	30	24	0.3	23.4	28	18.6	20 200	26 200

Notes⁽¹⁾ Minimum allowable value of chamfer dimension *r*
⁽²⁾ Allowable rotational speed applies to oil lubrication. For grease lubrication, a maximum of 50% of this value is allowable.
 Remarks1. The character "N" at the end of the identification number indicates that a synthetic resin cage is incorporated.
 2. RNAF has no oil hole. RNAFW is provided with an oil groove and an oil hole on the outer ring.
 3. No grease is prepacked. Perform proper lubrication.



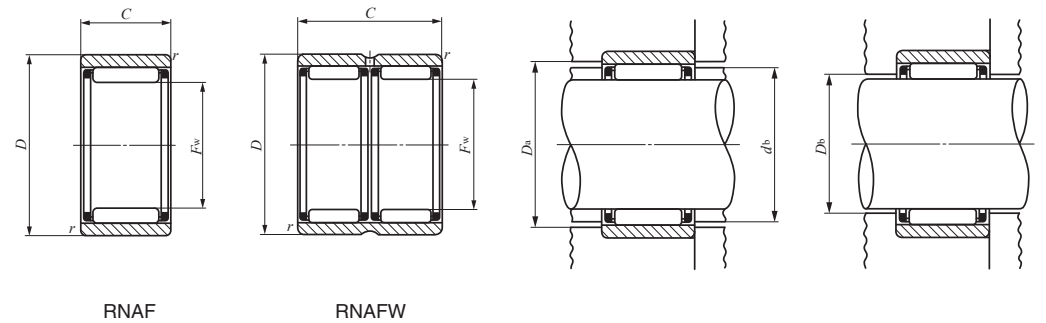
RNAF

RNAFW

Allowable rotational speed ⁽²⁾ min ⁻¹
85 000
75 000
65 000
60 000
60 000
50 000
50 000
40 000
35 000
35 000
35 000
35 000
35 000
35 000
30 000
30 000
30 000
30 000
30 000
30 000

NEEDLE ROLLER BEARINGS WITH SEPARABLE CAGE

Without Inner Ring



Shaft dia. 45 – 100mm

Shaft dia. mm	Identification number	Mass (Ref.) g	Boundary dimensions mm				Standard mounting dimensions mm			Basic dynamic load rating C N	Basic static load rating C ₀ N
			F _w	D	C	r _{s min} ⁽¹⁾	d _b	D _a Max.	D _b		
45	RNAF 455517	83.5	45	55	17	0.3	48.5	53	45.8	23 300	47 100
	RNAFW 455534	167	45	55	34	0.3	48.5	53	45.8	39 900	94 200
	RNAF 456220	184	45	62	20	0.3	50.9	60	45.8	33 200	53 300
	RNAFW 456240	370	45	62	40	0.3	50.9	60	45.8	56 900	107 000
50	RNAF 506220	138	50	62	20	0.3	54.2	60	50.8	27 100	59 300
	RNAFW 506240	275	50	62	40	0.3	54.2	60	50.8	46 400	119 000
	RNAF 506520	170	50	65	20	0.3	55.2	63	50.8	35 900	61 100
	RNAFW 506540	340	50	65	40	0.6	55.2	61	50.8	61 500	122 000
55	RNAF 556820	167	55	68	20	0.3	59.5	66	55.8	28 600	66 000
	RNAFW 556840	335	55	68	40	0.3	59.5	66	55.8	49 000	132 000
	RNAF 557220	220	55	72	20	1	60.9	67	55.8	37 400	66 400
	RNAFW 557240	440	55	72	40	1	60.9	67	55.8	64 100	133 000
60	RNAF 607820	255	60	78	20	1	66.3	73	60.8	38 900	71 700
	RNAFW 607840	510	60	78	40	1	66.3	73	60.8	66 700	143 000
65	RNAF 658530	470	65	85	30	1.5	72	77	66	59 300	127 000
	RNAFW 658560	945	65	85	60	1.5	72	77	66	102 000	255 000
70	RNAF 709030	500	70	90	30	1.5	77	82	71	61 200	136 000
	RNAFW 709060	1 000	70	90	60	1.5	77	82	71	105 000	272 000
75	RNAF 759530	530	75	95	30	1.5	82	87	76	63 100	144 000
	RNAFW 759560	1 060	75	95	60	1.5	82	87	76	108 000	289 000
80	RNAF 8010030	560	80	100	30	1.5	87	92	81	65 000	153 000
	RNAFW 8010060	1 120	80	100	60	1.5	87	92	81	111 000	306 000
85	RNAF 8510530	590	85	105	30	1.5	92	97	86	66 600	161 000
90	RNAF 9011030	625	90	110	30	1.5	97	102	91	69 600	174 000
95	RNAF 9511530	655	95	115	30	1.5	102	107	96	70 900	182 000
100	RNAF 10012030	685	100	120	30	1.5	107	112	101	72 500	191 000

Notes⁽¹⁾ Minimum allowable value of chamfer dimension *r*
⁽²⁾ Allowable rotational speed applies to oil lubrication. For grease lubrication, a maximum of 50% of this value is allowable.
 Remarks1. RNAF has no oil hole. RNAFW is provided with an oil groove and an oil hole on the outer ring.
 2. No grease is prepacked. Perform proper lubrication.

Allowable rotational speed ⁽²⁾ min ⁻¹
11 000
11 000
11 000
11 000
10 000
10 000
10 000
10 000
9 000
9 000
9 000
9 000
8 500
8 500
7 500
7 500
7 000
7 000
6 500
6 500
6 000
6 000
6 000
5 500
5 500
4 500

NEEDLE ROLLER BEARINGS WITH SEPARABLE CAGE

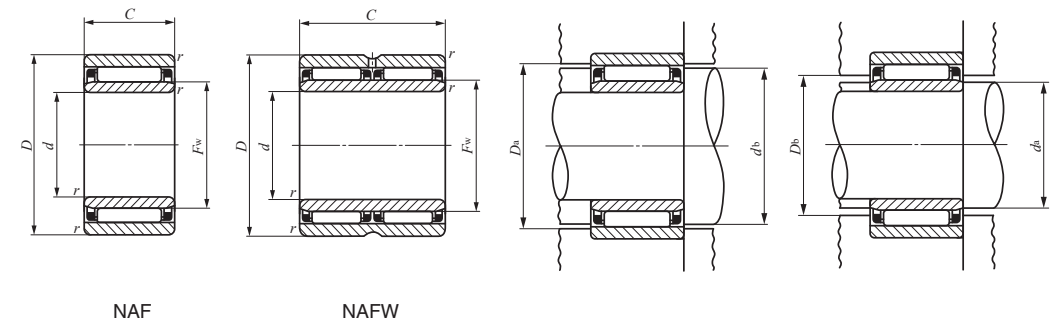
With Inner Ring



Shaft dia. 6 – 25mm

Shaft dia. mm	Identification number	Mass (Ref.) g	Boundary dimensions mm					Standard mounting dimensions mm				
			<i>d</i>	<i>D</i>	<i>C</i>	<i>r_{s min}</i> ⁽¹⁾	<i>F_w</i>	<i>d_b</i>	<i>D_a</i> Max.	<i>d_a</i> Min. Max.	<i>D_b</i>	
6	NAF 61710	13.5	6	17	10	0.3	10	12.4	15	8	9.7	10.4
7	NAF 72012	22.5	7	20	12	0.3	10	13.5	18	9	9.7	10.4
9	NAF 92212	24	9	22	12	0.3	12	15.5	20	11	11.5	12.4
10	NAF 102213	26	10	22	13	0.3	14	17.6	20	12	13	14.6
	NAFW 102220	40	10	22	20	0.3	14	17.6	20	12	13	14.6
	NAF 102612	36	10	26	12	0.3	14	19.4	24	12	13	14.6
12	NAF 122413	29.5	12	24	13	0.3	16	19.6	22	14	15	16.6
	NAFW 122420	45.5	12	24	20	0.3	16	19.6	22	14	15	16.6
	NAF 122812	40	12	28	12	0.3	16	21.4	26	14	15	16.6
15	NAF 152813	38.5	15	28	13	0.3	20	23.6	26	17	19	20.6
	NAFW 152826	77.5	15	28	26	0.3	20	23.6	26	17	19	20.6
	NAF 153212	50.5	15	32	12	0.3	20	25.4	30	17	19	20.6
17	NAF 173013	42.5	17	30	13	0.3	22	25.6	28	19	21	22.6
	NAFW 173026	84.5	17	30	26	0.3	22	25.6	28	19	21	22.6
	NAF 173516	77.5	17	35	16	0.3	22	27.8	33	19	21	22.6
	NAFW 173532	155	17	35	32	0.3	22	27.8	33	19	21	22.6
20	NAF 203517	74	20	35	17	0.3	25	29.5	33	22	24	25.6
	NAFW 203526	114	20	35	26	0.3	25	29.5	33	22	24	25.6
	NAF 203716	79	20	37	16	0.3	25	30.4	35	22	24	25.6
	NAFW 203732	158	20	37	32	0.3	25	30.4	35	22	24	25.6
25	NAF 254017	87.5	25	40	17	0.3	30	34.5	38	27	29	30.6
	NAFW 254026	135	25	40	26	0.3	30	34.5	38	27	29	30.6
	NAF 254216	94	25	42	16	0.3	30	35.4	40	27	29	30.6
	NAFW 254232	186	25	42	32	0.3	30	35.4	40	27	29	30.6

Notes⁽¹⁾ Minimum allowable value of chamfer dimension *r*
⁽²⁾ Allowable rotational speed applies to oil lubrication. For grease lubrication, a maximum of 50% of this value is allowable.
 Remarks1. NAF has no oil hole. NAFW is provided with an oil groove and an oil hole on the outer ring.
 2. No grease is prepacked. Perform proper lubrication.



Basic dynamic load rating <i>C</i> N	Basic static load rating <i>C₀</i> N	Allowable rotational speed ⁽²⁾ min ⁻¹	Assembled inner ring
4 160	4 550	50 000	LRT 61010
5 940	6 000	50 000	LRT 71012-1
9 030	8 460	40 000	LRT 91212
7 860	9 410	35 000	LRT 101413
10 800	14 200	35 000	LRT 101420
9 790	9 680	35 000	LRT 101412
8 620	11 000	30 000	LRT 121613
11 900	16 700	30 000	LRT 121620
10 500	10 900	30 000	LRT 121612
9 590	13 500	25 000	LRT 152013
16 400	27 100	25 000	LRT 152026
12 400	14 300	25 000	LRT 152012
10 200	15 200	25 000	LRT 172213
17 500	30 300	25 000	LRT 172226
17 600	20 900	25 000	LRT 172216
30 200	41 800	25 000	LRT 172232
17 300	26 600	20 000	LRT 202517
22 400	37 200	20 000	LRT 202526
19 400	24 500	20 000	LRT 202516
33 200	49 000	20 000	LRT 202532
18 700	31 100	17 000	LRT 253017
24 200	43 400	17 000	LRT 253026
20 800	28 400	17 000	LRT 253016
35 700	56 800	17 000	LRT 253032

NEEDLE ROLLER BEARINGS WITH SEPARABLE CAGE

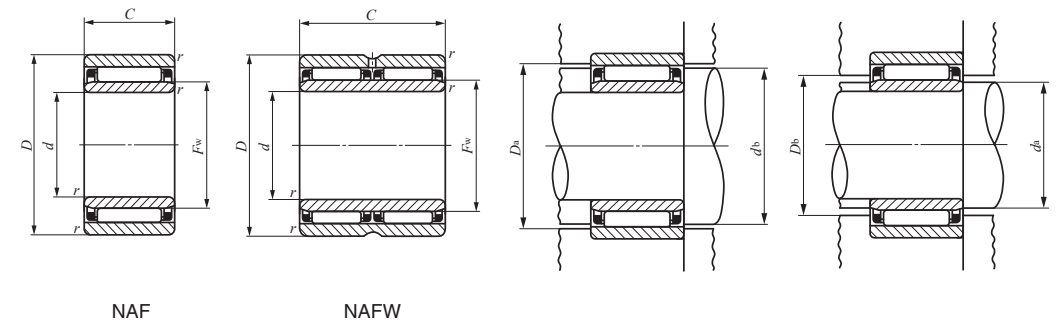
With Inner Ring



Shaft dia. 30 – 65mm

Shaft dia. mm	Identification number	Mass (Ref.) g	Boundary dimensions mm					Standard mounting dimensions mm				
			<i>d</i>	<i>D</i>	<i>C</i>	<i>r_{s min}</i> ⁽¹⁾	<i>F_w</i>	<i>d_b</i>	<i>D_a</i> Max.	<i>d_a</i> Min. Max.	<i>D_b</i>	
30	NAF 304517	101	30	45	17	0.3	35	39.5	43	32	34	35.6
	NAFW 304526	155	30	45	26	0.3	35	39.5	43	32	34	35.6
	NAF 304716	107	30	47	16	0.3	35	40.4	45	32	34	35.6
	NAFW 304732	215	30	47	32	0.3	35	40.4	45	32	34	35.6
35	NAF 355017	115	35	50	17	0.3	40	43.5	48	37	39	40.8
	NAFW 355034	230	35	50	34	0.3	40	43.5	48	37	39	40.8
	NAF 355520	186	35	55	20	0.3	40	45.2	53	37	39	40.8
	NAFW 355540	375	35	55	40	0.3	40	45.2	53	37	39	40.8
40	NAF 405517	128	40	55	17	0.3	45	48.5	53	42	44	45.8
	NAFW 405534	255	40	55	34	0.3	45	48.5	53	42	44	45.8
	NAF 406220	235	40	62	20	0.3	45	50.9	60	42	44	45.8
	NAFW 406240	475	40	62	40	0.3	45	50.9	60	42	44	45.8
45	NAF 456220	196	45	62	20	0.3	50	54.2	60	47	49	50.8
	NAFW 456240	390	45	62	40	0.3	50	54.2	60	47	49	50.8
	NAF 457220	340	45	72	20	1	55	60.9	67	50	54	55.8
	NAFW 457240	685	45	72	40	1	55	60.9	67	50	54	55.8
50	NAF 506820	230	50	68	20	0.3	55	59.5	66	52	54	55.8
	NAFW 506840	465	50	68	40	0.3	55	59.5	66	52	54	55.8
	NAF 507820	390	50	78	20	1	60	66.3	73	55	59	60.8
	NAFW 507840	775	50	78	40	1	60	66.3	73	55	59	60.8
55	NAF 558530	690	55	85	30	1.5	65	72	77	63	63.5	66
	NAFW 558560	1 380	55	85	60	1.5	65	72	77	63	63.5	66
60	NAF 609030	740	60	90	30	1.5	70	77	82	68	68.5	71
	NAFW 609060	1 480	60	90	60	1.5	70	77	82	68	68.5	71
65	NAF 659530	790	65	95	30	1.5	75	82	87	73	73.5	76
	NAFW 659560	1 580	65	95	60	1.5	75	82	87	73	73.5	76

Notes⁽¹⁾ Minimum allowable value of chamfer dimension *r*
⁽²⁾ Allowable rotational speed applies to oil lubrication. For grease lubrication, a maximum of 50% of this value is allowable.
 Remarks1. NAF has no oil hole. NAFW is provided with an oil groove and an oil hole on the outer ring.
 2. No grease is prepacked. Perform proper lubrication.



Basic dynamic load rating <i>C</i> N	Basic static load rating <i>C₀</i> N	Allowable rotational speed ⁽²⁾ min ⁻¹	Assembled inner ring
20 500	36 900	14 000	LRT 303517
26 600	51 500	14 000	LRT 303526
23 100	33 900	14 000	LRT 303516
39 500	67 800	14 000	LRT 303532
22 200	42 700	12 000	LRT 354017
38 000	85 400	12 000	LRT 354034
31 400	48 000	12 000	LRT 354020
53 900	96 000	12 000	LRT 354040
23 300	47 100	11 000	LRT 404517
39 900	94 200	11 000	LRT 404534
33 200	53 300	11 000	LRT 404520
56 900	107 000	11 000	LRT 404540
27 100	59 300	10 000	LRT 455020
46 400	119 000	10 000	LRT 455040
37 400	66 400	9 000	LRT 455520
64 100	133 000	9 000	LRT 455540
28 600	66 000	9 000	LRT 505520
49 000	132 000	9 000	LRT 505540
38 900	71 700	8 500	LRT 506020
66 700	143 000	8 500	LRT 506040
59 300	127 000	7 500	LRT 556530
102 000	255 000	7 500	LRT 556560
61 200	136 000	7 000	LRT 607030
105 000	272 000	7 000	LRT 607060
63 100	144 000	6 500	LRT 657530
108 000	289 000	6 500	LRT 657560

NEEDLE ROLLER BEARINGS WITH SEPARABLE CAGE

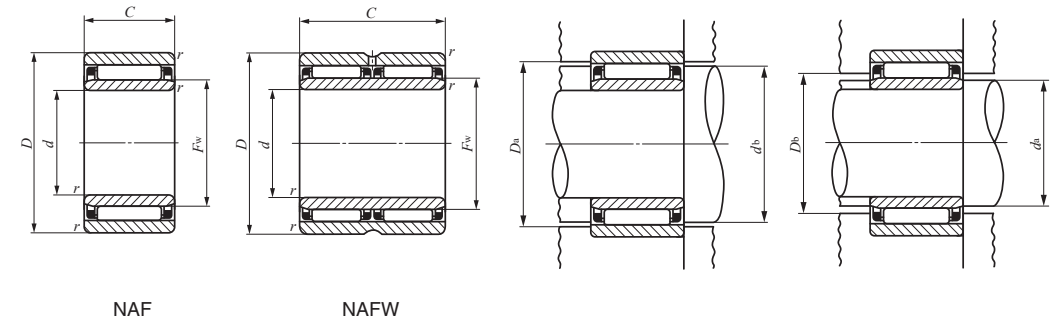
With Inner Ring



Shaft dia. 70 – 90mm

Shaft dia. mm	Identification number	Mass (Ref.) g	Boundary dimensions mm					Standard mounting dimensions mm				
			<i>d</i>	<i>D</i>	<i>C</i>	<i>r_{s min}</i> ⁽¹⁾	<i>F_w</i>	<i>d_b</i>	<i>D_a</i> Max.	<i>d_a</i> Min. Max.	<i>D_b</i>	
70	NAF 7010030	835	70	100	30	1.5	80	87	92	78	78.5	81
	NAFW 7010060	1 680	70	100	60	1.5	80	87	92	78	78.5	81
75	NAF 7510530	885	75	105	30	1.5	85	92	97	83	83.5	86
80	NAF 8011030	935	80	110	30	1.5	90	97	102	88	88.5	91
85	NAF 8511530	985	85	115	30	1.5	95	102	107	93	93.5	96
90	NAF 9012030	1 040	90	120	30	1.5	100	107	112	98	98.5	101

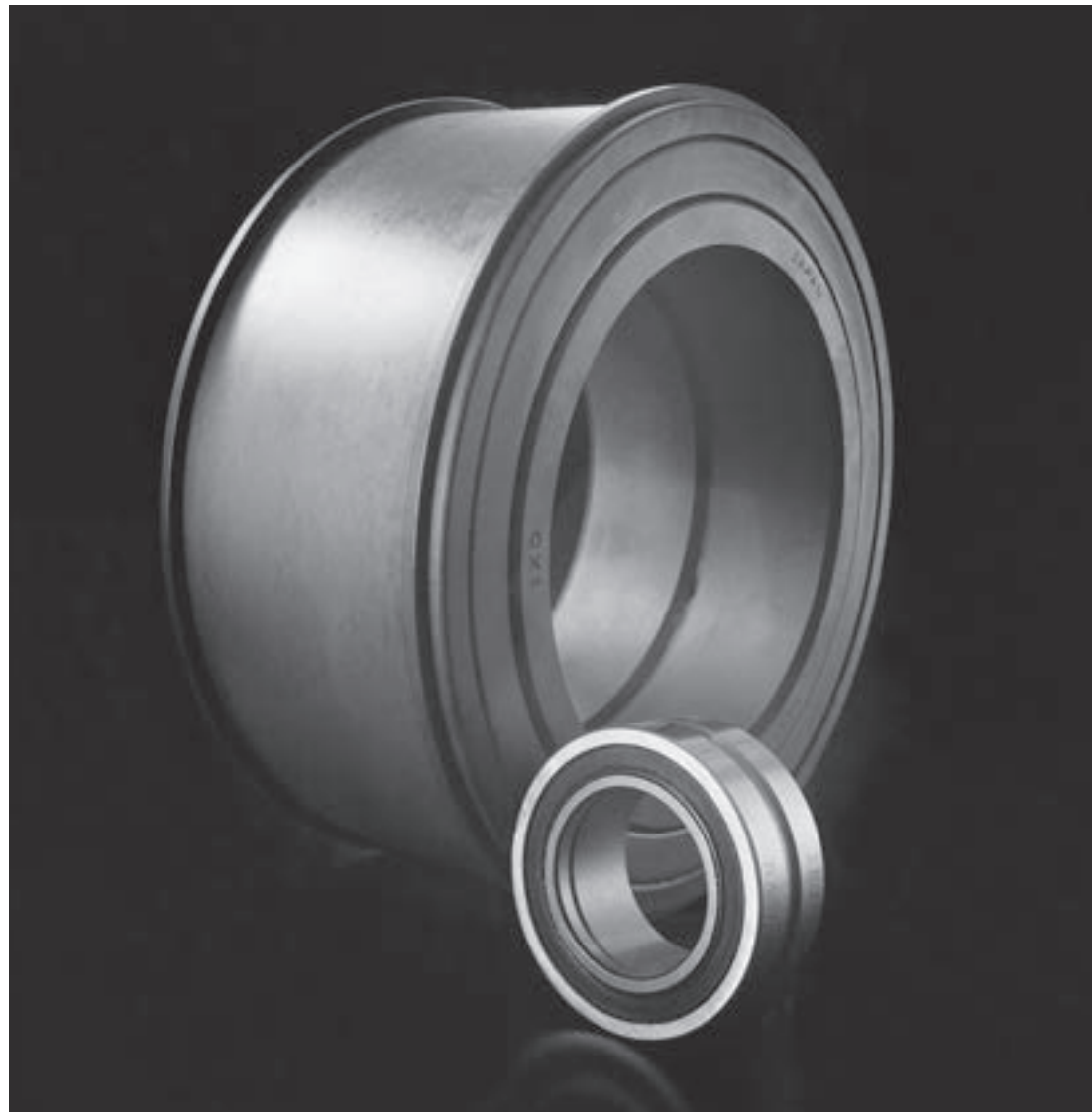
Notes⁽¹⁾ Minimum allowable value of chamfer dimension *r*
⁽²⁾ Allowable rotational speed applies to oil lubrication. For grease lubrication, a maximum of 50% of this value is allowable.
 Remarks1. NAF has no oil hole. NAFW is provided with an oil groove and an oil hole on the outer ring.
 2. No grease is prepacked. Perform proper lubrication.



Basic dynamic load rating <i>C</i> N	Basic static load rating <i>C₀</i> N	Allowable rotational speed ⁽²⁾ min ⁻¹	Assembled inner ring
65 000	153 000	6 000	LRT 708030-1
111 000	306 000	6 000	LRT 708060
66 600	161 000	6 000	LRT 758530-1
69 600	174 000	5 500	LRT 809030-1
70 900	182 000	5 500	LRT 859530
72 500	191 000	4 500	LRT 9010030

ROLLER BEARINGS

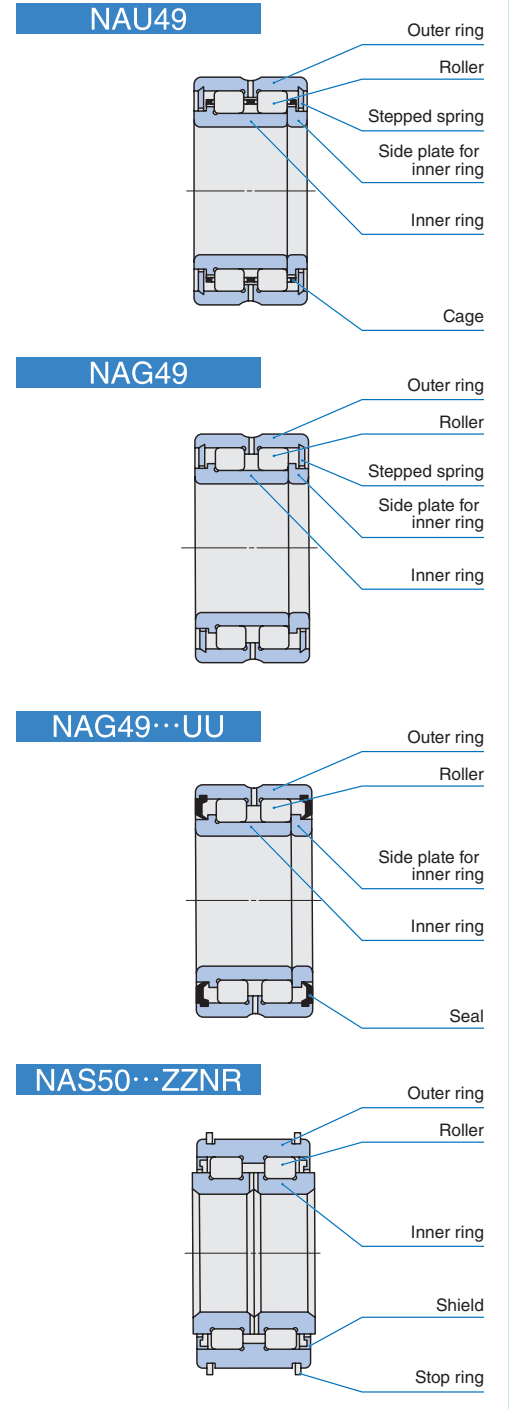
- Caged Roller Bearings
- Full Complement Roller Bearings
- Roller Bearings for Sheaves



Structure and Features

IKO Roller Bearings in which rollers are incorporated in two rows are non-separable heavy-duty bearings. They can withstand not only radial loads but axial loads as well, which are supported at the contacts between the shoulders of inner and outer rings and the end faces of rollers. Therefore, they are most suitable for use at the fixing side of a shaft. Like needle roller bearings, they are also compact. Roller bearings include the caged type, full complement type and the type for sheaves, and any bearings suitable for the operating conditions can be selected. In particular, these bearings are used for heavy-duty machines such as construction machinery, and industrial machinery.

Structures of Roller Bearings



Types

The types of Roller Bearings shown in Table 1 are available.

Table 1 Type of bearing

Type	Caged type	Full complement type	For sheaves
Standard	NAU49 TRU	NAG49	—
With seal	NAU49...UU TRU...UU	NAG49...UU	NAS50...UUNR
With shield	—	—	NAS50...ZZNR

Caged Roller Bearings

These bearings are suitable for high-speed rotations and fluctuating loads. Also, as the axial distance between the double-row rollers is comparatively large, large moment loads can be supported.

Caged roller bearings with seal incorporate seals on both sides. Synthetic resin rubber seals are excellent in the prevention of dust penetration and grease leakage, providing an excellent sealing effect.

Full Complement Roller Bearings

These bearings are suitable for low-speed rotations or oscillating motions and heavy loads. Similar to the caged type, the structure is advantageous for supporting moment loads.

The bearings with seal incorporate seals on both sides.

Roller Bearings for Sheaves

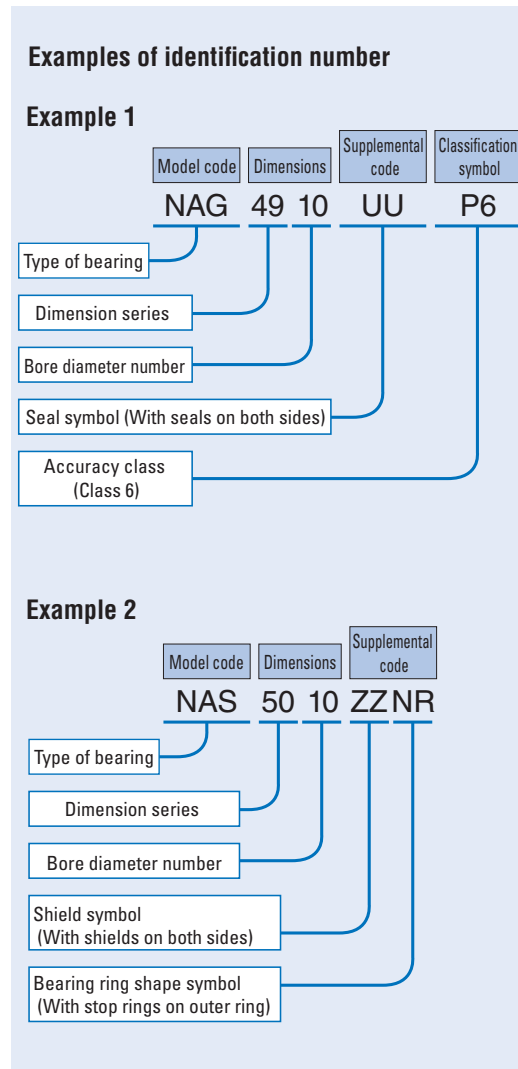
These bearings are the double-row full complement type with a low sectional height designed for use in sheaves. There are two types; the sealed type and the shield type. They can withstand heavy radial loads and shock loads at comparatively low-speed rotations, and can also withstand axial loads.

They can easily be fixed axially to sheaves using the stop rings of the outer ring. As the width of the inner ring is designed to be larger than that of the outer ring, they require no spacer between sheaves. The structure is stable because the double-row rollers can withstand the moment loads caused by rope transition.

The surfaces of these bearings are treated to have high corrosion resistance.

Identification Number

The identification number of Roller Bearings consists of a model code, dimensions, any supplemental codes and a classification symbol. The arrangement examples are shown below.



Accuracy

Roller Bearings are manufactured in accordance with JIS (See page A31.). A side plate for inner ring is assembled on one side of caged or full complement roller bearings. The tolerance of bore diameter of the side plate is shown below. Tolerances of Roller Bearings for Sheaves represent the values before surface treatment. The tolerance of internal distance between cir-clips is shown below.

Tolerance of bore diameter of the side plate d : E7
Tolerance of internal distance between cir-clips C_1 : 0~+0.4mm

Clearance

Roller Bearings are manufactured to the CN clearance shown in Table 18 on page A37. However, Roller Bearings for Sheaves are manufactured so that proper operating clearances are obtained after being mounted with a specified fit.

Fit

The recommended fits for Roller Bearings are shown in Tables 21 to 22 on pages A41 and A42. The recommended fits for Roller Bearings for Sheaves are shown in Table 2.

Table 2 Recommended fits for Roller Bearings for Sheaves

Tolerance class of shaft	Tolerance class of housing bore
g6	N7

Table 3 Bearings with prepacked grease

○ : With prepacked grease × : Without prepacked grease

Type	Standard	With seals	With shields
Caged type	NAU, TRU	×	○
Full complement type	NAG	×	○
For sheaves	NAS	—	○

Table 4 Number of oil holes of the inner ring and outer ring

Type	Nominal bore diameter d mm	Number of oil holes of the outer ring			Number of oil holes of the inner ring
		Standard	With seals	With shields	
Caged type	$d \leq 17$	0	0	—	0
	$17 < d$	2	2	—	
Full complement type	$d \leq 17$	0	0	—	0
	$17 < d$	2	2	—	
For sheaves	NAS	—	0	0	2

Remark The bearings with oil holes are also provided with an oil groove.

Lubrication

Bearings with prepacked grease are shown in Table 3. For Caged Roller Bearings and Full Complement Roller Bearings, ALVANIA GREASE S2 (Shell Lubricants Japan K.K.) is prepacked as the lubricating grease. For Roller Bearings for Sheaves, ALVANIA GREASE EP2 (Shell Lubricants Japan K.K.) is prepacked as the lubricating grease.

In the case of bearings without prepacked grease, perform proper lubrication for use. Operating without lubrication will increase the wear of the rolling contact surfaces and shorten their lives.

Oil Hole

The number of oil holes of the inner and outer rings is shown in Table 4.

Operating Temperature Range

The operating temperature range for Roller Bearings is $-20^{\circ}\text{C} \sim +120^{\circ}\text{C}$. However, the maximum allowable temperature for Roller Bearings for Sheaves is $+110^{\circ}\text{C}$.

Axial Load Capacity

Axial load capacity is not determined from the basic dynamic load rating based on rolling fatigue, but is determined by the amount of heat generated by sliding contact between the ends of rollers and guide shoulders of the inner and outer rings. It is therefore limited by the load conditions, sliding speeds, lubrication methods, etc.

The axial load capacity of Roller Bearings is obtained from the following equation.

If the axial load increases in comparison with the radial load, it will start to interfere with the smooth rolling motion. The axial load should therefore be within 20% of the radial load.

$$C_A = f_v a f_A \dots\dots\dots (1)$$

where, C_A : Axial load capacity N

f_v : Speed correction factor

f_v is obtained from Fig.2 by calculating the $d_m n$ value.

$$d_m n = d_m \times n$$

d_m : Mean value of bearing bore and outside diameters mm

$$\left(d_m \doteq \frac{d + D}{2} \right)$$

n : Rotational speed min^{-1}

When $d_m n \leq 1000$, $f_v = 1$.

a : Value determined by type of bearing (See Table 5.)

f_A : Axial load capacity factor (See Fig.1.)

Table 5 Value by type of bearing

Type of bearing	a
NAS 50	1
NAG 49	0.78
NAU 49, TRU	0.7

Calculation example

When a roller bearing for sheaves NAS 5016 ZZ NR is run at $n = 250 \text{ min}^{-1}$ under grease lubrication and subjected to an intermittent axial load, the axial load capacity is calculated as follows.

As the bearing bore diameter is 80 mm, $f_A = 18000$ is obtained from the axial load capacity line of Fig. 1 (ii).

$$a = 1$$

$$d_m \doteq \frac{80 + 125}{2} = 102.5$$

$$d_m n = 102.5 \times 250 \doteq 25600$$

From Fig. 2, $f_v \doteq 0.87$

Therefore, the axial load capacity C_A is obtained.

$$C_A = f_v a f_A = 0.87 \times 1 \times 18000 \doteq 15700 \text{ N}$$

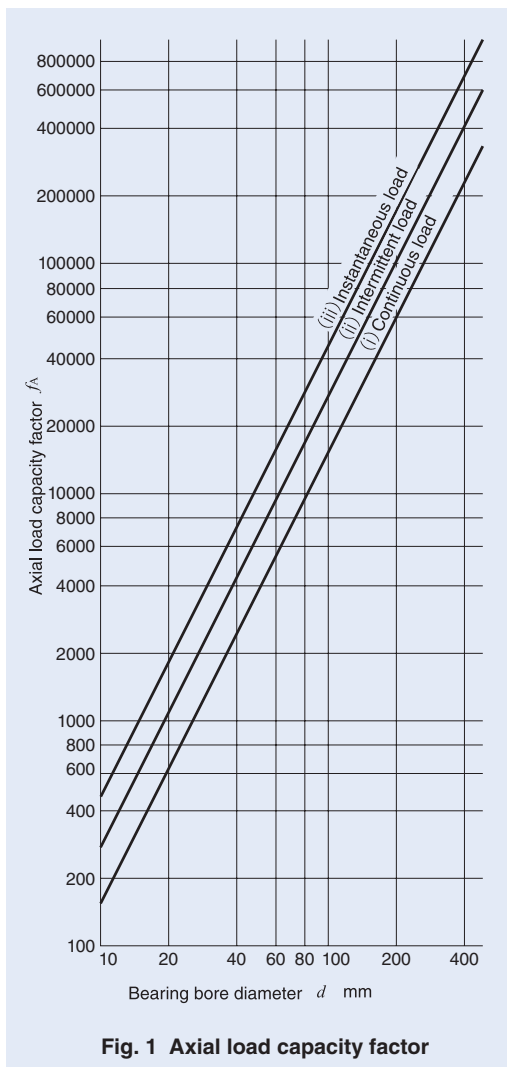


Fig. 1 Axial load capacity factor

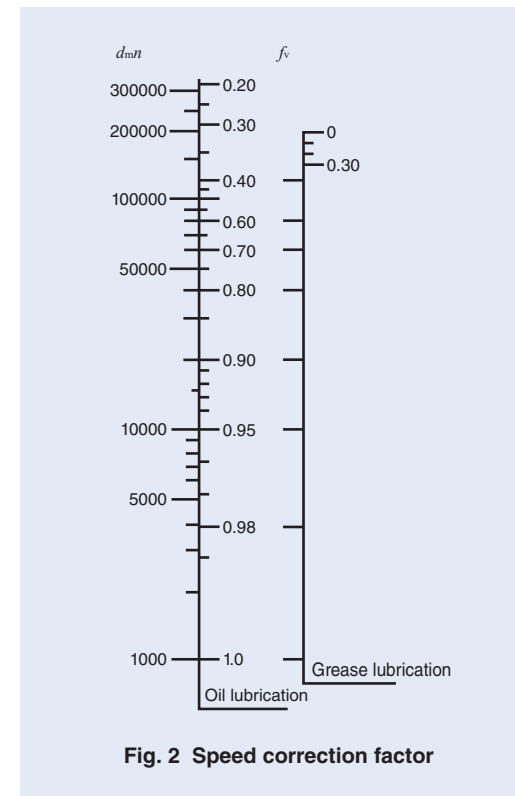


Fig. 2 Speed correction factor

Mounting

Unlike needle roller bearings, Caged and Full Complement Roller Bearings are non-separable.

As shown in Fig. 3 (1), the inner ring should be press-fitted until it makes close contact with the shaft shoulder, and fixed axially with a nut. Dimensions of the shoulders of the shaft and housing should be based on J and E_W shown in the table of dimensions, respectively.

In the case of Roller Bearings for Sheaves, as shown in Fig. 3 (2), the outer ring should be fixed by stop rings after being press-fitted into the sheaves, and the inner ring should be fixed securely in the axial direction.

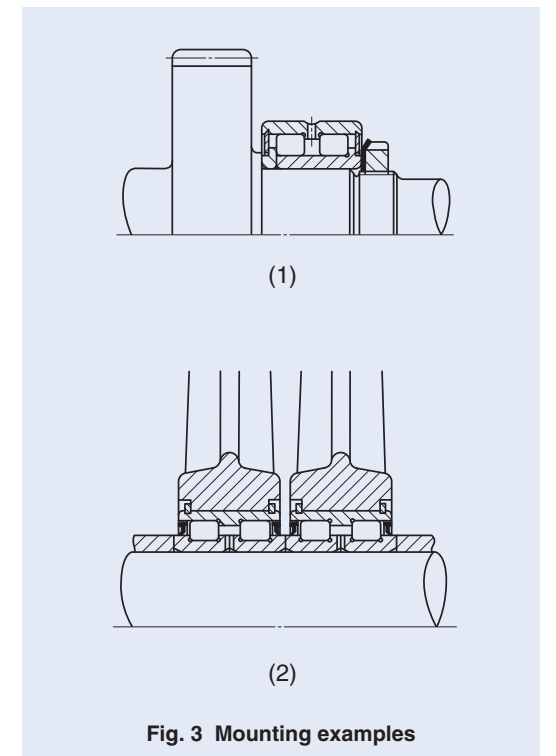
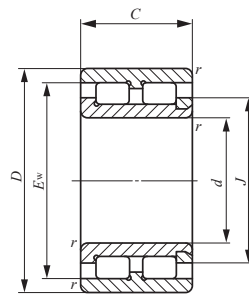


Fig. 3 Mounting examples

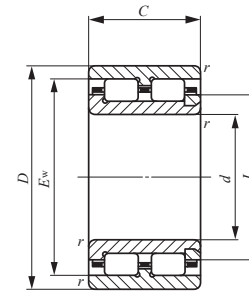
E
NAG
NAU
TRU
NAS

ROLLER BEARINGS

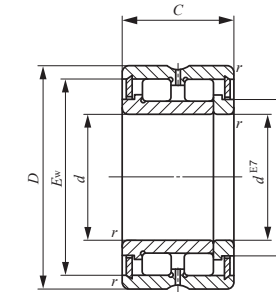
Caged Roller Bearings
Full Complement Roller Bearings



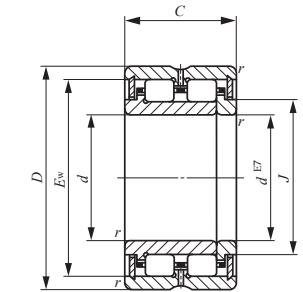
NAG49
($d \leq 17$)



NAU49
($d \leq 17$)



NAG49



NAU49 TRU

Shaft dia. 10 – 35mm

Shaft dia. mm	Identification number			Mass (Ref.) g	Boundary dimensions mm					
	Full complement type	Caged type			d	D	C	r_s min ⁽¹⁾	J	E_w
10	NAG 4900	—	—	25.5	10	22	13	0.3	15.5	18.5
	—	NAU 4900	—	24.5	10	22	13	0.3	15.5	18.5
12	NAG 4901	—	—	28.5	12	24	13	0.3	17	20
	—	NAU 4901	—	27.5	12	24	13	0.3	17	20
15	NAG 4902	—	—	38	15	28	13	0.3	21	24
	—	NAU 4902	—	36.5	15	28	13	0.3	21	24
	—	—	TRU 153320	80.5	15	33	20	0.3	19.5	27
17	NAG 4903	—	—	41	17	30	13	0.3	22.5	25.5
	—	NAU 4903	—	39.5	17	30	13	0.3	22.5	25.5
	—	—	TRU 173425	100	17	34	25	0.3	21.5	29.5
20	NAG 4904	—	—	76.5	20	37	17	0.3	24	31.5
	—	NAU 4904	—	76	20	37	17	0.3	24	31.5
	—	—	TRU 203820	96.5	20	38	20	0.3	25	32.5
	—	—	TRU 203825	122	20	38	25	0.3	25	32.5
25	NAG 4905	—	—	89.5	25	42	17	0.3	29.5	37
	—	NAU 4905	—	89	25	42	17	0.3	29.5	37
	—	—	TRU 254425	154	25	44	25	0.3	30.5	38
28	—	—	TRU 284530	173	28	45	30	0.3	31.5	39.5
30	NAG 4906	—	—	103	30	47	17	0.3	34	41.5
	—	NAU 4906	—	102	30	47	17	0.3	34	41.5
	—	—	TRU 304830	197	30	48	30	0.3	35	42.5
32	—	—	TRU 325230	260	32	52	30	0.6	38	46
35	NAG 4907	—	—	172	35	55	20	0.6	40	49
	—	NAU 4907	—	168	35	55	20	0.6	40	49
	—	—	TRU 355630	270	35	56	30	0.6	40	49

Notes⁽¹⁾ Minimum allowable value of chamfer dimension r
⁽²⁾ Allowable rotational speed applies to oil lubrication. For grease lubrication, a maximum of 60% of this value is allowable. Considering that the axial load acts under practical operating conditions, up to 1/10 of this value is recommended for actual use.
 Remarks1. The NAG and NAU series with a bore diameter d of 17 mm or less have no oil hole. In others, the outer ring has an oil groove and two oil holes.
 2. No grease is prepacked. Perform proper lubrication.

Basic dynamic load rating C N	Basic static load rating C_0 N	Allowable rotational speed ⁽²⁾ min ⁻¹
9 650	10 800	17 000
6 580	6 470	30 000
10 300	12 000	15 000
6 950	7 120	25 000
11 800	15 200	12 000
7 950	9 020	20 000
10 400	10 400	20 000
12 300	16 500	11 000
8 240	9 670	19 000
18 000	21 600	18 000
15 600	18 900	9 500
10 700	11 300	16 000
12 100	13 400	16 000
18 700	23 600	16 000
17 500	23 200	7 500
11 900	13 900	13 000
21 000	28 900	13 000
28 700	43 800	12 000
19 400	27 600	6 500
13 000	16 200	12 000
29 400	46 600	11 000
29 800	44 200	10 000
28 700	43 800	5 500
19 500	26 300	10 000
32 200	49 800	10 000

E
NAG
NAU
TRU
NAS

ROLLER BEARINGS

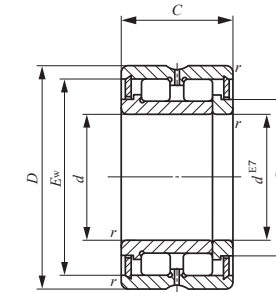
Caged Roller Bearings
Full Complement Roller Bearings



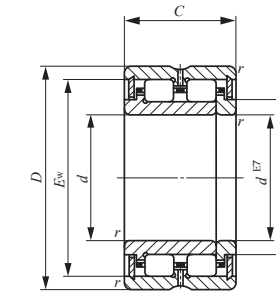
Shaft dia. 40 – 80mm

Shaft dia. mm	Identification number			Mass (Ref.) g	Boundary dimensions mm					
	Full complement type	Caged type			<i>d</i>	<i>D</i>	<i>C</i>	<i>r_{s min}</i> ⁽¹⁾	<i>J</i>	<i>E_w</i>
40	NAG 4908	—	—	225	40	62	22	0.6	46	56
	—	—	TRU 405930	265	40	59	30	0.6	45	52.5
	—	NAU 4908	—	220	40	62	22	0.6	46	56
42	—	—	TRU 426230	290	42	62	30	0.6	48	56.5
45	NAG 4909	—	—	265	45	68	22	0.6	51	61
	—	—	TRU 456430	295	45	64	30	0.6	50.5	58.5
	—	NAU 4909	—	260	45	68	22	0.6	51	61
50	NAG 4910	—	—	270	50	72	22	0.6	55.5	65.5
	—	NAU 4910	—	265	50	72	22	0.6	55.5	65.5
	—	—	TRU 507745	710	50	77	45	1	58	69
55	NAG 4911	—	—	395	55	80	25	1	61.5	72.5
	—	NAU 4911	—	385	55	80	25	1	61.5	72.5
	—	—	TRU 558138	615	55	81	38	1	61.5	72.5
60	NAG 4912	—	—	425	60	85	25	1	67	77.5
	—	NAU 4912	—	415	60	85	25	1	67	77.5
	—	—	TRU 608945	880	60	89	45	1	69.5	81.5
65	NAG 4913	—	—	455	65	90	25	1	72	83
	—	NAU 4913	—	440	65	90	25	1	72	83
70	NAG 4914	—	—	725	70	100	30	1	79	91.5
	—	NAU 4914	—	705	70	100	30	1	79	91.5
75	NAG 4915	—	—	775	75	105	30	1	83.5	95.5
	—	NAU 4915	—	750	75	105	30	1	83.5	95.5
	—	—	TRU 7510845	1 240	75	108	45	1	85.5	98.5
80	NAG 4916	—	—	815	80	110	30	1	89.5	102
	—	NAU 4916	—	790	80	110	30	1	89.5	102

Notes⁽¹⁾ Minimum allowable value of chamfer dimension *r*
⁽²⁾ Allowable rotational speed applies to oil lubrication. For grease lubrication, a maximum of 60% of this value is allowable. Considering that the axial load acts under practical operating conditions, up to 1/10 of this value is recommended for actual use.
 Remarks1. The outer ring has an oil groove and two oil holes.
 2. No grease is prepacked. Perform proper lubrication.



NAG49



NAU49 TRU

Basic dynamic load rating <i>C</i> N	Basic static load rating <i>C₀</i> N	Allowable rotational speed ⁽²⁾ min ⁻¹
34 600	49 500	5 000
34 700	62 500	8 500
23 400	29 400	8 500
34 600	57 800	8 000
36 400	54 700	4 500
32 600	59 700	8 000
24 800	32 800	8 000
38 200	59 900	4 000
26 200	36 200	7 000
75 700	134 000	7 000
48 100	77 700	3 500
33 000	47 000	6 500
61 400	104 000	6 500
50 300	84 300	3 500
34 700	51 400	6 000
88 100	152 000	6 000
53 200	93 000	3 000
36 900	57 100	5 500
77 700	139 000	3 000
53 700	84 600	5 000
80 000	146 000	2 500
54 800	88 200	5 000
103 000	190 000	4 500
83 000	157 000	2 500
57 200	95 500	4 500

E
NAG
NAU
TRU
NAS

ROLLER BEARINGS

Caged Roller Bearings
Full Complement Roller Bearings

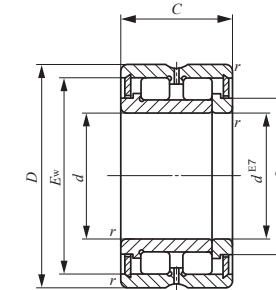


Shaft dia. 85 – 140mm

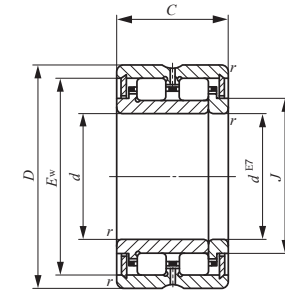
Shaft dia. mm	Identification number			Mass (Ref.) g	Boundary dimensions mm					
	Full complement type	Caged type			<i>d</i>	<i>D</i>	<i>C</i>	⁽¹⁾ <i>r_{s min}</i>	<i>J</i>	<i>E_w</i>
85	NAG 4917	—	—	1 190	85	120	35	1.5	96	110
	—	—	TRU 8511850	1 530	85	118	50	1	94.5	107.5
	—	NAU 4917	—	1 150	85	120	35	1.5	96	110
	—	—	TRU 8512045	1 500	85	120	45	1.5	96.5	110
90	NAG 4918	—	—	1 250	90	125	35	1.5	101	115.5
	—	NAU 4918	—	1 210	90	125	35	1.5	101	115.5
	—	—	TRU 9012550	1 740	90	125	50	1.5	101	114
95	NAG 4919	—	—	1 300	95	130	35	1.5	106	120.5
	—	NAU 4919	—	1 270	95	130	35	1.5	106	120.5
100	NAG 4920	—	—	1 850	100	140	40	1.5	114.5	129.5
	—	—	TRU 10013550	1 900	100	135	50	1.5	112	125.5
	—	NAU 4920	—	1 770	100	140	40	1.5	114.5	129.5
105	—	—	TRU 10515350	2 890	105	153	50	1.5	120	138
110	NAG 4922	—	—	2 010	110	150	40	1.5	123	138.5
	—	NAU 4922	—	1 930	110	150	40	1.5	123	138.5
120	NAG 4924	—	—	2 780	120	165	45	1.5	136	153.5
	—	NAU 4924	—	2 680	120	165	45	1.5	136	153.5
125	—	—	TRU 12517860	4 490	125	178	60	1.5	143.5	162
130	NAG 4926	—	—	3 750	130	180	50	2	147	165.5
	—	NAU 4926	—	3 610	130	180	50	2	147	165.5
135	—	—	TRU 13518860	4 790	135	188	60	1.5	154	172.5
140	NAG 4928	—	—	3 990	140	190	50	2	157.5	176
	—	NAU 4928	—	3 840	140	190	50	2	157.5	176

Notes⁽¹⁾ Minimum allowable value of chamfer dimension *r*
⁽²⁾ Allowable rotational speed applies to oil lubrication. For grease lubrication, a maximum of 60% of this value is allowable. Considering that the axial load acts under practical operating conditions, up to 1/10 of this value is recommended for actual use.

- Remarks1. The outer ring has an oil groove and two oil holes.
 2. No grease is prepacked. Perform proper lubrication.



NAG49



NAU49 TRU

Basic dynamic load rating <i>C</i> N	Basic static load rating <i>C₀</i> N	Allowable rotational speed ⁽²⁾ min ⁻¹
111 000	200 000	2 500
114 000	222 000	4 000
75 400	120 000	4 000
110 000	215 000	4 000
114 000	211 000	2 500
79 500	130 000	4 000
119 000	240 000	4 000
117 000	222 000	2 000
81 000	136 000	4 000
152 000	292 000	2 000
124 000	264 000	3 500
106 000	181 000	3 500
159 000	286 000	3 500
161 000	322 000	1 900
113 000	200 000	3 500
208 000	431 000	1 700
146 000	268 000	3 000
211 000	408 000	3 000
240 000	495 000	1 600
166 000	304 000	2 500
220 000	442 000	2 500
249 000	531 000	1 500
174 000	327 000	2 500

E

NAG
NAU
TRU
NAS

ROLLER BEARINGS

Caged Roller Bearings With Seal

Full Complement Roller Bearings With Seal



Shaft dia. 10 – 40mm

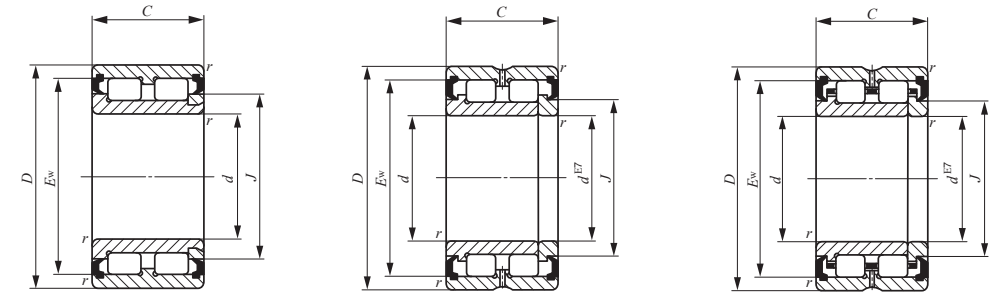
Shaft dia. mm	Identification number			Mass (Ref.) g	Boundary dimensions mm				
	Full complement type	Caged type			<i>d</i>	<i>D</i>	<i>C</i>	<i>r_{s min}</i> ⁽¹⁾	<i>J</i>
10	NAG 4900UU	—	—	25.5	10	22	13	0.3	15.5
12	NAG 4901UU	—	—	28.5	12	24	13	0.3	17
15	NAG 4902UU	—	—	38	15	28	13	0.3	21
	—	—	TRU 153320UU	80.5	15	33	20	0.3	19.5
17	NAG 4903UU	—	—	41	17	30	13	0.3	22.5
	—	—	TRU 173425UU	100	17	34	25	0.3	21.5
20	NAG 4904UU	—	—	76.5	20	37	17	0.3	24
	—	NAU 4904UU	—	76	20	37	17	0.3	24
	—	—	TRU 203820UU	96.5	20	38	20	0.3	25
	—	—	TRU 203825UU	122	20	38	25	0.3	25
25	NAG 4905UU	—	—	89.5	25	42	17	0.3	29.5
	—	NAU 4905UU	—	89	25	42	17	0.3	29.5
	—	—	TRU 254425UU	154	25	44	25	0.3	30.5
28	—	—	TRU 284530UU	173	28	45	30	0.3	31.5
30	NAG 4906UU	—	—	103	30	47	17	0.3	34
	—	NAU 4906UU	—	102	30	47	17	0.3	34
	—	—	TRU 304830UU	197	30	48	30	0.3	35
32	—	—	TRU 325230UU	260	32	52	30	0.6	38
35	NAG 4907UU	—	—	172	35	55	20	0.6	40
	—	NAU 4907UU	—	168	35	55	20	0.6	40
	—	—	TRU 355630UU	270	35	56	30	0.6	40
40	NAG 4908UU	—	—	225	40	62	22	0.6	46
	—	—	TRU 405930UU	265	40	59	30	0.6	45
	—	NAU 4908UU	—	220	40	62	22	0.6	46

Notes⁽¹⁾ Minimum allowable value of chamfer dimension *r*

⁽²⁾ Allowable rotational speed applies to grease lubrication. Considering that the axial load acts under practical operating conditions, up to 1/10 of this value is recommended for actual use.

Remarks1. The NAG and NAU series with a bore diameter, *d*, of 17 mm or less have no oil hole. In others, the outer ring has an oil groove and two oil holes.

2. The bearings with seals are provided with prepacked grease.



NAG49 ... UU
(*d* ≤ 17)

NAG49 ... UU

NAU49 ... UU
TRU ... UU

<i>E_w</i>	Basic dynamic load rating <i>C</i> N	Basic static load rating <i>C₀</i> N	Allowable rotational speed ⁽²⁾ min ⁻¹
19.5	9 650	10 800	10 000
21	10 300	12 000	9 000
25	11 800	15 200	7 000
27	10 400	10 400	9 500
26.5	12 300	16 500	6 500
29.5	18 000	21 600	8 500
31.5	15 600	18 900	5 500
31.5	10 700	11 300	8 000
32.5	12 100	13 400	7 500
32.5	18 700	23 600	7 500
37	17 500	23 200	4 500
37	11 900	13 900	6 500
38	21 000	28 900	6 000
39.5	28 700	43 800	6 000
41.5	19 400	27 600	4 000
41.5	13 000	16 200	5 500
42.5	29 400	46 600	5 500
46	29 800	44 200	5 000
49	28 700	43 800	3 500
49	19 500	26 300	4 500
49	32 200	49 800	4 500
56	34 600	49 500	3 000
52.5	34 700	62 500	4 000
56	23 400	29 400	4 000

E
NAG
NAU
TRU
NAS

ROLLER BEARINGS

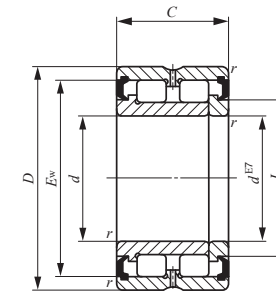
Caged Roller Bearings **With Seal**
 Full Complement Roller Bearings **With Seal**



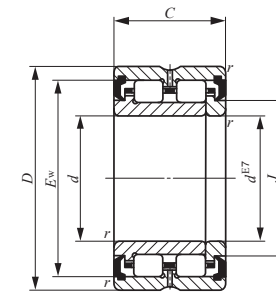
Shaft dia. 42 – 80mm

Shaft dia. mm	Identification number			Mass (Ref.) g	Boundary dimensions mm				
	Full complement type	Caged type			<i>d</i>	<i>D</i>	<i>C</i>	<i>r_s</i> min ⁽¹⁾	<i>J</i>
42	—	—	TRU 426230UU	290	42	62	30	0.6	48
45	NAG 4909UU	—	—	265	45	68	22	0.6	51
	—	—	TRU 456430UU	295	45	64	30	0.6	50.5
	—	NAU 4909UU	—	260	45	68	22	0.6	51
50	NAG 4910UU	—	—	270	50	72	22	0.6	55.5
	—	NAU 4910UU	—	265	50	72	22	0.6	55.5
	—	—	TRU 507745UU	710	50	77	45	1	58
55	NAG 4911UU	—	—	395	55	80	25	1	61.5
	—	NAU 4911UU	—	385	55	80	25	1	61.5
	—	—	TRU 558138UU	615	55	81	38	1	61.5
60	NAG 4912UU	—	—	425	60	85	25	1	67
	—	NAU 4912UU	—	415	60	85	25	1	67
	—	—	TRU 608945UU	880	60	89	45	1	69.5
65	NAG 4913UU	—	—	455	65	90	25	1	72
	—	NAU 4913UU	—	440	65	90	25	1	72
70	NAG 4914UU	—	—	725	70	100	30	1	79
	—	NAU 4914UU	—	705	70	100	30	1	79
75	NAG 4915UU	—	—	775	75	105	30	1	83.5
	—	NAU 4915UU	—	750	75	105	30	1	83.5
	—	—	TRU 7510845UU	1 240	75	108	45	1	85.5
80	NAG 4916UU	—	—	815	80	110	30	1	89.5
	—	NAU 4916UU	—	790	80	110	30	1	89.5

Notes⁽¹⁾ Minimum allowable value of chamfer dimension *r*
⁽²⁾ Allowable rotational speed applies to grease lubrication. Considering that the axial load acts under practical operating conditions, up to 1/10 of this value is recommended for actual use.
 Remarks1. The outer ring has an oil groove and two oil holes.
 2. The bearings with seals are provided with prepacked grease.



NAG49 ... UU



NAU49 ... UU
 TRU ... UU

<i>E_w</i>	Basic dynamic load rating	Basic static load rating	Allowable rotational speed ⁽²⁾
	<i>C</i>	<i>C₀</i>	
	N	N	min ⁻¹
56.5	34 600	57 800	4 000
61	36 400	54 700	2 500
58.5	32 600	59 700	3 500
61	24 800	32 800	3 500
65.5	38 200	59 900	2 500
65.5	26 200	36 200	3 500
69	75 700	134 000	3 500
72.5	48 100	77 700	2 000
72.5	33 000	47 000	3 000
72.5	61 400	104 000	3 000
77.5	50 300	84 300	2 000
77.5	34 700	51 400	3 000
81.5	88 100	152 000	3 000
83	53 200	93 000	1 900
83	36 900	57 100	2 500
91.5	77 700	139 000	1 800
91.5	53 700	84 600	2 500
95.5	80 000	146 000	1 700
95.5	54 800	88 200	2 500
98.5	103 000	190 000	2 000
102	83 000	157 000	1 600
102	57 200	95 500	2 000

E
 NAG
 NAU
 TRU
 NAS

ROLLER BEARINGS

Caged Roller Bearings With Seal

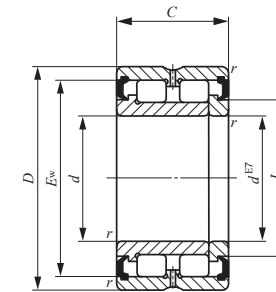
Full Complement Roller Bearings With Seal



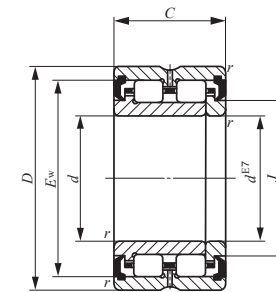
Shaft dia. 85 – 140mm

Shaft dia. mm	Identification number			Mass (Ref.) g	Boundary dimensions mm				
	Full complement type	Caged type			<i>d</i>	<i>D</i>	<i>C</i>	<i>r_s</i> min ⁽¹⁾	<i>J</i>
85	NAG 4917UU	—	—	1 190	85	120	35	1.5	96
	—	—	TRU 8511850UU	1 530	85	118	50	1	94.5
	—	NAU 4917UU	—	1 150	85	120	35	1.5	96
	—	—	TRU 8512045UU	1 500	85	120	45	1.5	96.5
90	NAG 4918UU	—	—	1 250	90	125	35	1.5	101
	—	NAU 4918UU	—	1 210	90	125	35	1.5	101
	—	—	TRU 9012550UU	1 740	90	125	50	1.5	101
95	NAG 4919UU	—	—	1 300	95	130	35	1.5	106
	—	NAU 4919UU	—	1 270	95	130	35	1.5	106
100	NAG 4920UU	—	—	1 850	100	140	40	1.5	114.5
	—	—	TRU 10013550UU	1 900	100	135	50	1.5	112
	—	NAU 4920UU	—	1 770	100	140	40	1.5	114.5
105	—	—	TRU 10515350UU	2 890	105	153	50	1.5	120
110	NAG 4922UU	—	—	2 010	110	150	40	1.5	123
	—	NAU 4922UU	—	1 930	110	150	40	1.5	123
120	NAG 4924UU	—	—	2 780	120	165	45	1.5	136
	—	NAU 4924UU	—	2 680	120	165	45	1.5	136
125	—	—	TRU 12517860UU	4 490	125	178	60	1.5	143.5
130	NAG 4926UU	—	—	3 750	130	180	50	2	147
	—	NAU 4926UU	—	3 610	130	180	50	2	147
135	—	—	TRU 13518860UU	4 790	135	188	60	1.5	154
140	NAG 4928UU	—	—	3 990	140	190	50	2	157.5
	—	NAU 4928UU	—	3 840	140	190	50	2	157.5

Notes⁽¹⁾ Minimum allowable value of chamfer dimension *r*
⁽²⁾ Allowable rotational speed applies to grease lubrication. Considering that the axial load acts under practical operating conditions, up to 1/10 of this value is recommended for actual use.
 Remarks1. The outer ring has an oil groove and two oil holes.
 2. The bearings with seals are provided with prepacked grease.



NAG49...UU



NAU49...UU
TRU...UU

<i>E_w</i>	Basic dynamic load rating <i>C</i> N	Basic static load rating <i>C₀</i> N	Allowable rotational speed ⁽²⁾ min ⁻¹
110	111 000	200 000	1 500
107.5	114 000	222 000	2 000
110	75 400	120 000	2 000
110	110 000	215 000	2 000
115.5	114 000	211 000	1 400
115.5	79 500	130 000	1 900
114	119 000	240 000	1 900
120.5	117 000	222 000	1 300
120.5	81 000	136 000	1 800
129.5	152 000	292 000	1 200
125.5	124 000	264 000	1 700
129.5	106 000	181 000	1 700
138	159 000	286 000	1 600
138.5	161 000	322 000	1 100
138.5	113 000	200 000	1 600
153.5	208 000	431 000	1 000
153.5	146 000	268 000	1 400
162	211 000	408 000	1 400
165.5	240 000	495 000	950
165.5	166 000	304 000	1 300
172.5	220 000	442 000	1 300
176	249 000	531 000	900
176	174 000	327 000	1 200

E
NAG
NAU
TRU
NAS

ROLLER BEARINGS

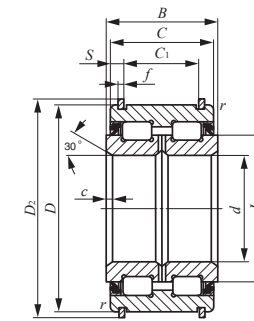
Roller Bearings for Sheaves



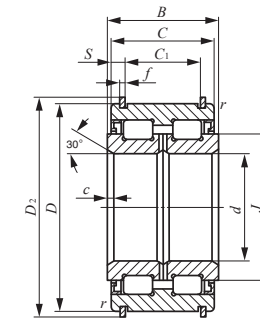
Shaft dia. 40 – 170mm

Shaft dia. mm	Identification number		Mass (Ref.) kg	Boundary dimensions mm						
	Sealed type	Shield type		<i>d</i>	<i>D</i>	<i>D</i> ₂	<i>B</i>	<i>C</i>	<i>C</i> ₁	<i>S</i>
40	NAS 5008UUNR	NAS 5008ZZNR	0.55	40	68	71.8	38	37	28	4.5
45	NAS 5009UUNR	NAS 5009ZZNR	0.70	45	75	78.8	40	39	30	4.5
50	NAS 5010UUNR	NAS 5010ZZNR	0.75	50	80	83.8	40	39	30	4.5
55	NAS 5011UUNR	NAS 5011ZZNR	1.15	55	90	94.8	46	45	34	5.5
60	NAS 5012UUNR	NAS 5012ZZNR	1.20	60	95	99.8	46	45	34	5.5
65	NAS 5013UUNR	NAS 5013ZZNR	1.30	65	100	104.8	46	45	34	5.5
70	NAS 5014UUNR	NAS 5014ZZNR	1.90	70	110	114.5	54	53	42	5.5
75	NAS 5015UUNR	NAS 5015ZZNR	2.00	75	115	119.5	54	53	42	5.5
80	NAS 5016UUNR	NAS 5016ZZNR	2.65	80	125	129.5	60	59	48	5.5
85	NAS 5017UUNR	NAS 5017ZZNR	2.80	85	130	134.5	60	59	48	5.5
90	NAS 5018UUNR	NAS 5018ZZNR	3.70	90	140	145.4	67	66	54	6
95	NAS 5019UUNR	NAS 5019ZZNR	3.90	95	145	150.4	67	66	54	6
100	NAS 5020UUNR	NAS 5020ZZNR	4.05	100	150	155.4	67	66	54	6
110	NAS 5022UUNR	NAS 5022ZZNR	6.50	110	170	175.4	80	79	65	7
120	NAS 5024UUNR	NAS 5024ZZNR	6.95	120	180	188.4	80	79	65	7
130	NAS 5026UUNR	NAS 5026ZZNR	10.5	130	200	208.4	95	94	77	8.5
140	NAS 5028UUNR	NAS 5028ZZNR	11.0	140	210	218.4	95	94	77	8.5
150	NAS 5030UUNR	NAS 5030ZZNR	13.5	150	225	233.4	100	99	81	9
160	NAS 5032UUNR	NAS 5032ZZNR	16.5	160	240	248.4	109	108	89	9.5
170	NAS 5034UUNR	NAS 5034ZZNR	22.5	170	260	270	122	121	99	11

Notes⁽¹⁾ Minimum allowable value of chamfer dimension *r*
⁽²⁾ Allowable rotational speed applies to grease lubrication. Considering that the axial load acts under practical operating conditions, up to 1/10 of this value is recommended for actual use.
 Remarks1. The inner ring has an oil groove and two oil holes.
 2. Roller Bearings for Sheaves are provided with prepacked grease.



NAS50...UUNR



NAS50...ZZNR

<i>f</i>	<i>c</i>	<i>r</i> _{s min} ⁽¹⁾	<i>J</i>	Basic dynamic load rating	Basic static load rating	Allowable rotational speed ⁽²⁾
				<i>C</i> N	<i>C</i> ₀ N	
2	1.5	0.6	50	79 500	116 000	2 500
2	1.5	0.6	56	95 500	144 000	2 000
2	1.5	0.6	61	100 000	158 000	2 000
2.5	2	0.6	68	118 000	193 000	1 800
2.5	2	0.6	73	123 000	208 000	1 700
2.5	2	0.6	78	128 000	224 000	1 600
2.5	2	0.6	84	171 000	284 000	1 400
2.5	2	0.6	91	179 000	308 000	1 300
2.5	2	0.6	97	251 000	428 000	1 300
2.5	2	0.6	101	257 000	446 000	1 200
2.5	2.5	0.6	110	305 000	540 000	1 100
2.5	2.5	0.6	114	312 000	562 000	1 100
2.5	2.5	0.6	118	318 000	584 000	1 000
2.5	3	1	130	384 000	697 000	900
3	3	1	139.5	400 000	750 000	850
3	3	1	156	537 000	1 000 000	750
3	3	1	167	543 000	1 070 000	700
3	3.5	1	176.5	623 000	1 210 000	650
3	3.5	1.5	188.5	720 000	1 390 000	650
4	3.5	1.5	204.5	857 000	1 730 000	600

E
NAG
NAU
TRU
NAS

ROLLER BEARINGS

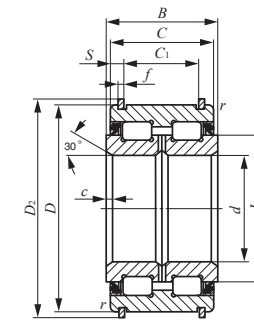
Roller Bearings for Sheaves



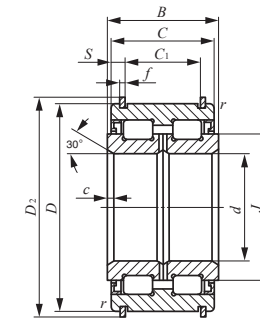
Shaft dia. 180 – 280mm

Shaft dia. mm	Identification number		Mass (Ref.) kg	Boundary dimensions mm						
	Sealed type	Shield type		<i>d</i>	<i>D</i>	<i>D</i> ₂	<i>B</i>	<i>C</i>	<i>C</i> ₁	<i>S</i>
180	NAS 5036UUNR	NAS 5036ZZNR	30.0	180	280	294	136	135	110	12.5
190	NAS 5038UUNR	NAS 5038ZZNR	31.5	190	290	306	136	135	110	12.5
200	NAS 5040UUNR	NAS 5040ZZNR	40.5	200	310	326	150	149	120	14.5
220	NAS 5044UUNR	NAS 5044ZZNR	52.0	220	340	356	160	159	130	14.5
240	NAS 5048UUNR	NAS 5048ZZNR	55.5	240	360	376	160	159	130	14.5
260	NAS 5052UUNR	NAS 5052ZZNR	85.0	260	400	416	190	189	154	17.5
280	NAS 5056UUNR	NAS 5056ZZNR	90.9	280	420	440	190	189	154	17.5

Notes⁽¹⁾ Minimum allowable value of chamfer dimension *r*
⁽²⁾ Allowable rotational speed applies to grease lubrication. Considering that the axial load acts under practical operating conditions, up to 1/10 of this value is recommended for actual use.
 Remarks1. The inner ring has an oil groove and two oil holes.
 2. Roller Bearings for Sheaves are provided with prepacked grease.



NAS50...UUNR



NAS50...ZZNR

<i>f</i>	<i>c</i>	<i>r</i> _{s min} ⁽¹⁾	<i>J</i>	Basic dynamic load rating	Basic static load rating	Allowable rotational speed ⁽²⁾ min ⁻¹
				<i>C</i> N	<i>C</i> ₀ N	
5	3.5	1.5	217	1 070 000	2 140 000	550
5	3.5	1.5	225	1 120 000	2 230 000	500
5	3.5	1.5	242	1 310 000	2 650 000	500
6	4	1.5	260	1 510 000	3 110 000	450
6	4	1.5	278.5	1 570 000	3 350 000	400
7	5	2	312	2 130 000	4 510 000	350
7	5	2	335	2 210 000	4 860 000	350

E
 NAG
 NAU
 TRU
 NAS

THRUST BEARINGS

- Thrust Needle Roller Bearings
- Thrust Roller Bearings



Structure and Features

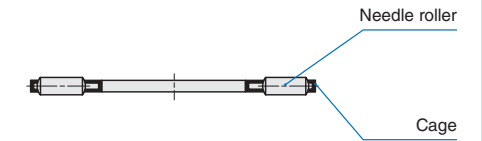
IKO Thrust Bearings consist of a precisely made cage and rollers. They have high rigidity and high load capacities and can be used in small spaces.

Thrust Needle Roller Bearings incorporate needle rollers, while Thrust Roller Bearings incorporate cylindrical rollers. Various types of raceway rings are available, and suitable bearings can be selected according to the operating conditions.

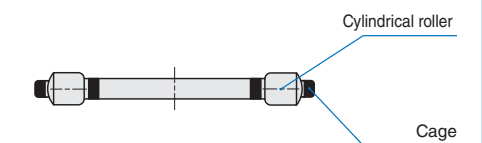
When the bearing mounting surfaces of a machine are heat-treated and finished by grinding as raceways, Thrust Bearings can be used without raceway rings allowing the machine to be made more compact. They are most suited to applications where high accuracy is required at high speeds and under fluctuating heavy loads, such as driving mechanisms for automobiles, machine tools, and high-pressure pumps.

Structures of Thrust Bearings

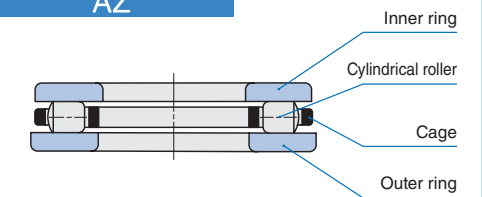
NTB



AZK



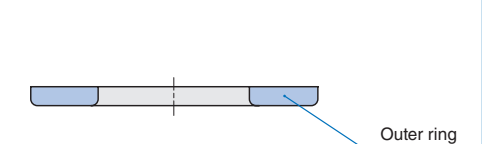
AZ



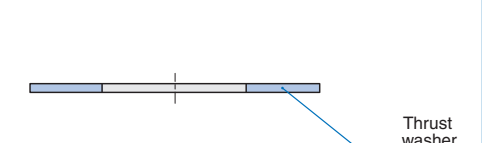
WS



GS



AS



F

NTB
AS
AZK
WS·GS

Types

In IKO Thrust Bearings, the types shown in Table 1 are available.

Table 1.1 Type of bearing

Type	Thrust needle roller bearings	Thrust roller bearings	
		Without inner and outer rings	With inner and outer rings
Model code	NTB	AZK	AZ

Table 1.2 Type of bearing ring

Type	Inner ring	Outer ring	Thrust washer
Model code	WS	GS	AS

Thrust Needle Roller Bearings

These bearings consist of a cage made from a steel plate, which is precisely press formed and surface-hardened, and needle rollers with a diameter variation within $2 \mu\text{m}$. They have a rigid structure and a high lubricant-retaining capacity.

As they have the lowest sectional height compared with other thrust bearings, they can be used instead of conventional thrust washers and can withstand high-speed rotations with a low coefficient of friction. Specially designed thin inner rings (WS) and outer rings (GS), and especially thin (1 mm thick) thrust washers (AS), are available for use in various applications.

These bearings are generally used by utilizing their inner surface as the guide surface.

Thrust Roller Bearings

In this series, the caged cylindrical rollers AZK and the complete bearings AZ in which AZK are combined with an inner ring (WS) and an outer ring (GS) are available.

The cage has a special precise structure which is highly rigid, and cylindrical rollers are outwardly arranged and guided by the cage with exact precision to enable them to withstand heavy loads even at high rotational speeds.

Owing to the high accuracy of the bearing height T , they are suitable for use in machine tools, ultra-high pressure pumps, etc.

These bearings are generally used by utilizing their inner surface as the guide surface.

Identification Number

The identification number of Thrust Bearings consists of a model code, dimensions and a classification symbol. Some examples are shown below.

Examples of identification number

Example 1 (In case of NTB or AS)

Model code	Dimensions
NTB	25 42

Type of bearing: NTB
 Bore diameter (25mm)
 Outside diameter (42mm)

Example 2 (In case of AZ or AZK)

Model code	Dimensions	Classification symbol
AZ	25 42 11	P5

Type of bearing: AZ
 Bore diameter (25mm)
 Outside diameter (42mm)
 Bearing height (11mm)
 Accuracy class⁽¹⁾ (Class 5)

Example 3 (In case of WS or GS)

Model code	Dimensions	Classification symbol
WS	25 42	P5

Type of bearing ring: WS
 Bore diameter (25mm)
 Outside diameter (42mm)
 Accuracy class (Class 5)

Note⁽¹⁾ Not applicable to the model AZK.

Accuracy

The accuracy of Thrust Bearings is based on JIS B 1514-2, -3 as shown in Table 2.

Table 2.1 Tolerances

unit: μm

Type of bearing	Item	Dimension	Dimension symbol	Tolerance	
Thrust needle roller bearings	NTB	Bore diameter	d	E11	
		Outside diameter	D	c12	
		Width	D_w	Equivalent to JIS B 1506 Class 2	
Thrust roller bearings	AZK	Bore diameter	d_c	As per Table 2.2	
		Outside diameter	D_c		
	AZ	Width	D_w	$1 \leq D_w \leq 10$	Equivalent to JIS B 1506 Class 2
				$10 < D_w \leq 30$	Equivalent to JIS B 1506 Class 3
Inner rings	WS	Bore diameter	d	As per Table 2.4	
		Outside diameter	D	b12	
		Width	B	h11	
Outer rings	GS	Bore diameter	d	B12	
		Outside diameter	D	As per Table 2.4	
		Width	B	h11	
Thrust washers	AS	Bore diameter	d	E12	
		Outside diameter	D	e12	
		Width	s	± 50	

Table 2.2 Tolerances of bore and outside diameters for AZK series

unit: μm

Nominal dimension mm	Δ_{dc} Cage bore diameter deviation		Δ_{Dc} Cage outside diameter deviation	
	Over	Incl.	High	Low
—	50	—	+ 100	0
50	100	—	+ 200	0
100	200	—	+ 300	0
200	300	—	+ 500	0
300	400	—	+ 700	0
400	500	—	—	0

Table 2.3 Tolerances of height for AZ series

unit: μm

Nominal bearing bore dia. mm	Δ_{Ts} Deviation of an actual bearing height	
	Over	Incl.
—	18	0
18	30	0
30	50	0
50	80	0
80	120	0
120	180	0
180	250	0
250	315	0
315	400	0
400	500	0

Table 2.4 Tolerances and allowable values for WS and GS

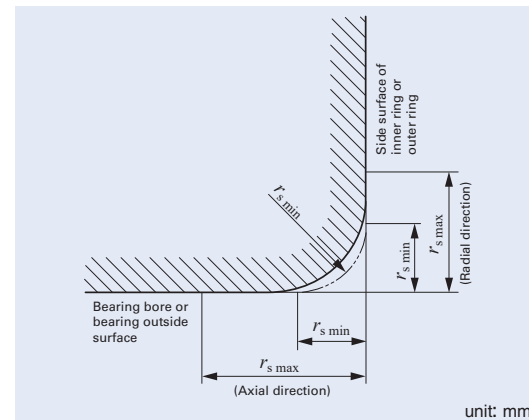
unit: μm

d or D (1) Nominal bearing bore dia. or outside dia. mm		Inner ring			Outer ring			Inner ring or outer ring		
		Δ_{dmp} Single plane mean bore diameter deviation		V_{dsp} Bore diameter variation in a sin- gle radial plane	Δ_{Dmp} Single plane mean outside diameter deviation		V_{Dsp} Outside diameter variation in a sin- gle radial plane	S_i or S_e (2) Bearing ring thickness variation		
		High	Low	Max.	High	Low	Max.	Class 0	Class 6	Class 5
Over	Incl.									
—	18	0	- 8	6	0	- 11	8	10	5	3
18	30	0	- 10	8	0	- 13	10	10	5	3
30	50	0	- 12	9	0	- 16	12	10	6	3
50	80	0	- 15	11	0	- 19	14	10	7	4
80	120	0	- 20	15	0	- 22	17	15	8	4
120	180	0	- 25	19	0	- 25	19	15	9	5
180	250	0	- 30	23	0	- 30	23	20	10	5
250	315	0	- 35	26	0	- 35	26	25	13	7
315	400	0	- 40	30	0	- 40	30	30	15	7
400	500	0	- 45	34	0	- 45	34	30	18	9

Notes(1) d for Δ_{dmp} and V_{dsp} , and D for Δ_{Dmp} and V_{Dsp} , respectively.
d for thickness variations of inner and outer rings .

(2) d_i for thickness variations of rings for NAX(I) and NBX(I) .

Table 2.5 Permissible limit values for chamfer dimension



unit: mm

r_s min	Radial and axial directions	
	r_s max	
0.3	0.8	
0.6	1.5	
1	2.2	
1.1	2.7	
1.5	3.5	
2	4	
2.1	4.5	
3	5.5	
4	6.5	
5	8	

Fit

The recommended fits for Thrust Bearings are shown in Table 3.

Table 3 Recommended fits

Type of bearing		Tolerance class	
		Shaft	Housing bore
Thrust needle roller bearings	NTB	h8	—
	AZK	h6	—
Thrust roller bearings	AZ	h6	H7
	WS	h6	—
Outer rings	GS	—	H7
Thrust washers	AS	h8	—

Mounting

When mounting Thrust Bearings, the following items should be considered.

① When inner and outer rings are not used, the hardness of the raceway surfaces should be 58 ~ 64HRC, the effective hardening depth should be adequate, and the surface roughness should be less than $0.2 \mu m R_a$.

② When mounting inner and outer rings to shaft and housing bore, dimensions related to mounting should be based on the dimension tables.

Also, the mounting surfaces should be finished at right angles to the center axis and they should be sufficiently rigid.

③ To avoid elastic deformation, the thrust washer AS must be seated uniformly on its mating surface.

A small warp in an AS washer will be corrected automatically when an axial load is applied.

④ Thrust Roller Bearings are combinations of a copper alloy component and cylindrical rollers. When handling the AZK itself, care should be taken to prevent deformations, blemishes, etc.

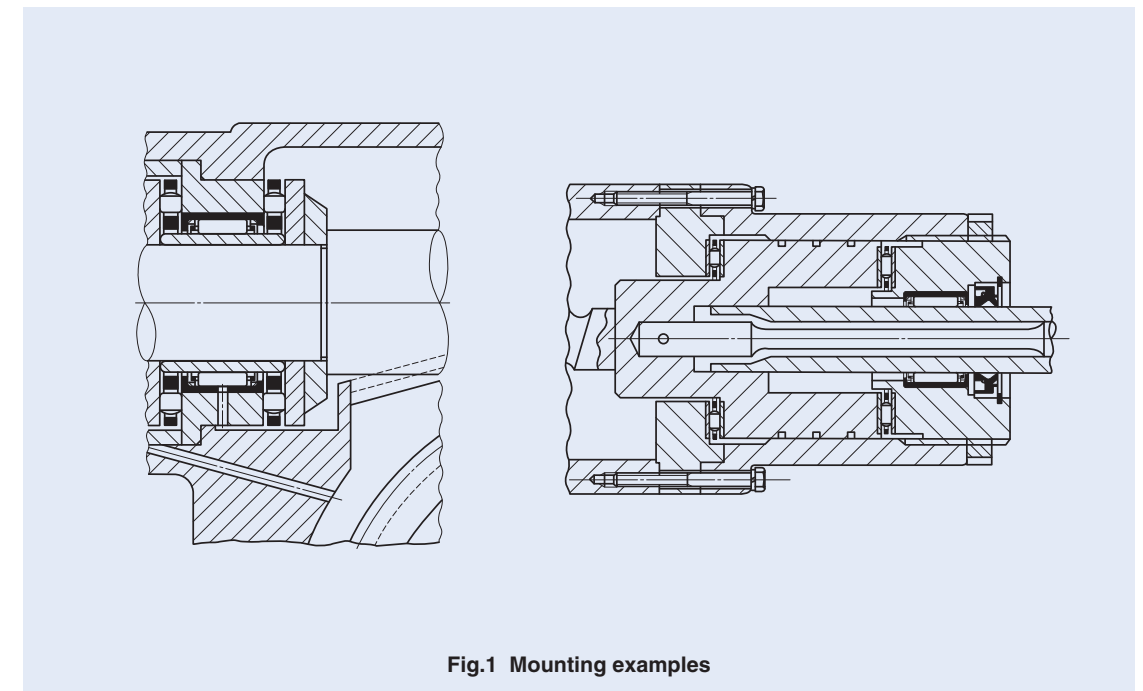


Fig.1 Mounting examples

THRUST BEARINGS

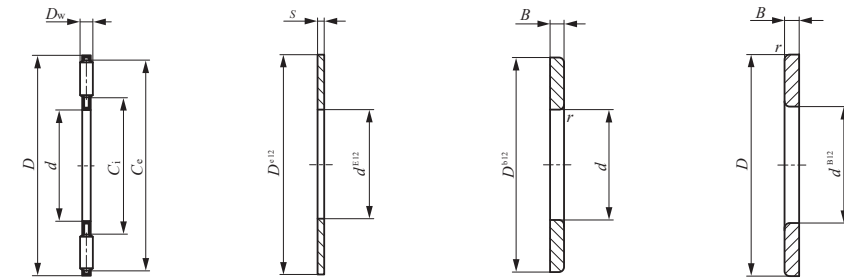
Thrust Needle Roller Bearings



Shaft dia. 10 – 85mm

Shaft dia. mm	Identification number						
	Thrust needle roller bearing	Mass (Ref.) g	Thrust washer	Mass (Ref.) g	Inner ring	Outer ring	Mass (Ref.) g
10	NTB 1024	3.3	AS 1024	2.9	WS 1024	GS 1024	8
12	NTB 1226	3.8	AS 1226	3.2	WS 1226	GS 1226	8.9
15	NTB 1528	4.1	AS 1528	3.4	WS 1528	GS 1528	9.3
16	NTB 1629	4.3	AS 1629	3.6	WS 1629	GS 1629	9.8
17	NTB 1730	4.5	AS 1730	3.7	WS 1730	GS 1730	10.2
18	NTB 1831	4.7	AS 1831	3.9	WS 1831	GS 1831	10.7
20	NTB 2035	6.1	AS 2035	5	WS 2035	GS 2035	13.8
25	NTB 2542	8.2	AS 2542	6.9	WS 2542	GS 2542	21
30	NTB 3047	9.4	AS 3047	7.9	WS 3047	GS 3047	24
35	NTB 3552	10.6	AS 3552	8.9	WS 3552	GS 3552	31.5
40	NTB 40603	22	AS 4060	12.1	WS 4060	GS 4060	42.5
45	NTB 4565	24.5	AS 4565	13.3	WS 4565	GS 4565	53.5
50	NTB 5070	26.5	AS 5070	14.5	WS 5070	GS 5070	58.5
55	NTB 5578	33.5	AS 5578	18.5	WS 5578	GS 5578	93
60	NTB 6085	38.5	AS 6085	22	WS 6085	GS 6085	105
65	NTB 6590	41.5	AS 6590	23.5	WS 6590	GS 6590	124
70	NTB 7095	61	AS 7095	25	WS 7095	GS 7095	132
75	NTB 75100	65	AS 75100	26.5	WS 75100	GS 75100	153
80	NTB 80105	68.5	AS 80105	28	WS 80105	GS 80105	162
85	NTB 85110	72	AS 85110	29.5	WS 85110	GS 85110	170

Notes⁽¹⁾ Minimum allowable value of chamfer dimension *r*
⁽²⁾ Allowable rotational speed applies to oil lubrication. For grease lubrication, a maximum of 25% of this value is allowable.



NTB

AS

WS

GS

d	Boundary dimensions mm							Basic dynamic load rating C N	Basic static load rating C ₀ N	Allowable rotational speed ⁽²⁾ min ⁻¹
	D	D _w	s	B	r _{s min} ⁽¹⁾	C _i	C _e			
10	24	2	1	2.75	0.3	14	22	7 820	23 900	15 000
12	26	2	1	2.75	0.3	16	24	8 340	26 900	13 000
15	28	2	1	2.75	0.3	18	26	8 830	29 900	12 000
16	29	2	1	2.75	0.3	19	27	9 070	31 400	11 000
17	30	2	1	2.75	0.3	20	28	9 320	32 900	11 000
18	31	2	1	2.75	0.3	21	29	9 550	34 400	10 000
20	35	2	1	2.75	0.3	23	33	11 700	46 500	9 000
25	42	2	1	3	0.6	29	40	14 400	64 700	7 500
30	47	2	1	3	0.6	34	45	15 400	73 300	6 500
35	52	2	1	3.5	0.6	39	50	16 300	81 900	5 500
40	60	3	1	3.5	0.6	45	57	24 200	108 000	5 000
45	65	3	1	4	0.6	50	62	25 900	121 000	4 500
50	70	3	1	4	0.6	55	67	27 600	135 000	4 000
55	78	3	1	5	0.6	61	75	32 400	171 000	4 000
60	85	3	1	4.75	1	66	82	38 200	219 000	3 500
65	90	3	1	5.25	1	71	87	40 100	237 000	3 000
70	95	4	1	5.25	1	75	91	47 400	244 000	3 000
75	100	4	1	5.75	1	80	96	48 400	256 000	3 000
80	105	4	1	5.75	1	85	101	49 500	267 000	2 500
85	110	4	1	5.75	1	90	106	50 300	279 000	2 500

F

NTB
AS
AZK
WS-GS

THRUST BEARINGS

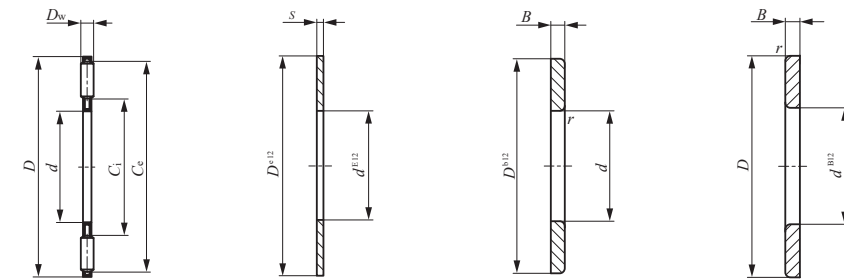
Thrust Needle Roller Bearings



Shaft dia. 90 – 130mm

Shaft dia. mm	Identification number						
	Thrust needle roller bearing	Mass (Ref.) g	Thrust washer	Mass (Ref.) g	Inner ring	Outer ring	Mass (Ref.) g
90	NTB 90120	92	AS 90120	38	WS 90120	GS 90120	250
100	NTB 100135	119	AS 100135	50	WS 100135	GS 100135	350
110	NTB 110145	129	—	—	WS 110145	GS 110145	380
120	NTB 120155	139	—	—	WS 120155	GS 120155	410
130	NTB 130170	225	—	—	WS 130170	GS 130170	660

Notes⁽¹⁾ Minimum allowable value of chamfer dimension r
⁽²⁾ Allowable rotational speed applies to oil lubrication. For grease lubrication, a maximum of 25% of this value is allowable.



NTB AS WS GS

d	D	Boundary dimensions mm							Basic dynamic load rating C N	Basic static load rating C_0 N	Allowable rotational speed ⁽²⁾ min ⁻¹
		D_w	s	B	$r_{s \min}^{(1)}$	C_i	C_e				
90	120	4	1	6.5	1	96	116	64 500	394 000	2 500	
100	135	4	1	7	1	107	131	80 300	541 000	2 000	
110	145	4	—	7	1	117	141	83 200	578 000	2 000	
120	155	4	—	7	1	127	151	87 900	634 000	1 800	
130	170	5	—	9	1	137	165	120 000	839 000	1 700	

F
 NTB
 AS
 AZK
 WS-GS

THRUST BEARINGS

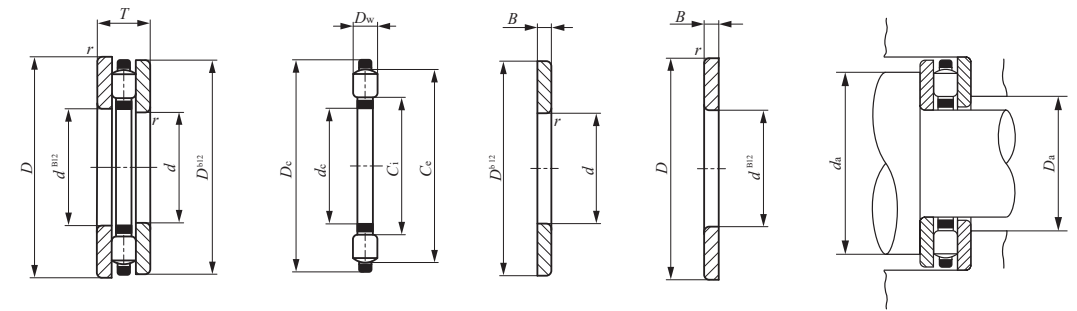
Thrust Roller Bearings



Shaft dia. 10 – 65mm

Shaft dia. mm	Identification number							
	Thrust roller bearing	Mass (Ref.) g	Thrust roller bearing	Mass (Ref.) g	Inner ring	Outer ring	Mass (Ref.) g	
10	AZ 10249	24.6	AZK 10243.5	8.6	WS 1024	GS 1024	8	
12	AZ 12269	26.5	AZK 12263.5	8.7	WS 1226	GS 1226	8.9	
15	AZ 15289	28	AZK 15283.5	9.4	WS 1528	GS 1528	9.3	
17	AZ 17309	30.5	AZK 17303.5	10.1	WS 1730	GS 1730	10.2	
20	AZ 203510	45.5	AZK 20354.5	17.9	WS 2035	GS 2035	13.8	
25	AZ 254211	70	AZK 25425	28	WS 2542	GS 2542	21	
30	AZ 304711	79	AZK 30475	31	WS 3047	GS 3047	24	
	AZ 305216	160	AZK 30527.5	70	WS 3052	GS 3052	45	
35	AZ 355212	99	AZK 35525	36	WS 3552	GS 3552	31.5	
	AZ 356218	260	AZK 35627.5	98	WS 3562	GS 3562	81	
40	AZ 406013	139	AZK 40606	54	WS 4060	GS 4060	42.5	
	AZ 406819	310	AZK 40689	132	WS 4068	GS 4068	89	
45	AZ 456514	169	AZK 45656	62	WS 4565	GS 4565	53.5	
	AZ 457320	360	AZK 45739	144	WS 4573	GS 4573	108	
50	AZ 507014	185	AZK 50706	68	WS 5070	GS 5070	58.5	
	AZ 507822	430	AZK 507811	194	WS 5078	GS 5078	118	
55	AZ 557816	275	AZK 55786	89	WS 5578	GS 5578	93	
	AZ 559025	725	AZK 559011	275	WS 5590	GS 5590	225	
60	AZ 608517	345	AZK 60857.5	135	WS 6085	GS 6085	105	
	AZ 609526	770	AZK 609511	290	WS 6095	GS 6095	240	
	AZ 6013026	2 090	AZK 6013010	790	WS 60130	GS 60130	650	
65	AZ 659018	380	AZK 65907.5	132	WS 6590	GS 6590	124	
	AZ 6510027	860	AZK 6510011	310	WS 65100	GS 65100	275	

Notes⁽¹⁾ Minimum allowable value of chamfer dimension *r*
⁽²⁾ Allowable rotational speed applies to oil lubrication. For grease lubrication, a maximum of 25% of this value is allowable.



AZ AZK WS GS

Boundary dimensions mm											Standard mounting dimensions mm		Basic dynamic load rating C N	Basic static load rating C ₀ N	Allowable rotational speed ⁽²⁾ min ⁻¹
<i>d</i>	<i>D</i>	<i>T</i>	<i>d_c</i>	<i>D_c</i>	<i>D_w</i>	<i>B</i>	<i>r_{s min}</i> ⁽¹⁾	<i>C_i</i>	<i>C_e</i>	<i>d_{a Min.}</i>	<i>D_{a Max.}</i>				
10	24	9	10.04	23.6	3.5	2.75	0.3	13	21	21	13	8 990	19 100	18 000	
12	26	9	12.04	25.6	3.5	2.75	0.3	15	23	23	16	10 400	23 900	16 000	
15	28	9	15.04	27.6	3.5	2.75	0.3	17	25	25	18	10 200	23 900	14 000	
17	30	9	17.04	29.6	3.5	2.75	0.3	19	27	27	20	11 400	28 600	13 000	
20	35	10	20.04	34.6	4.5	2.75	0.3	22	33	33	23	19 000	48 700	11 000	
25	42	11	25.05	41.6	5	3	0.6	28	39	39	28	22 700	60 700	9 000	
30	47	11	30.05	46.5	5	3	0.6	33	44	44	33	27 400	81 000	8 000	
	52	16	30.05	51.5	7.5	4.25	0.6	35	49	48	36	38 400	95 700	7 500	
35	52	12	35.05	51.5	5	3.5	0.6	38	49	49	39	29 100	91 100	7 000	
	62	18	35.05	61.5	7.5	5.25	1	42	58	57	43	47 900	135 000	6 500	
40	60	13	40.05	59.5	6	3.5	0.6	44	57	57	44	41 700	133 000	6 000	
	68	19	40.05	67.5	9	5	1	45	64	64	46	68 700	195 000	5 500	
45	65	14	45.05	64.5	6	4	0.6	49	62	62	49	40 800	133 000	5 500	
	73	20	45.05	72.5	9	5.5	1	50	69	69	51	75 700	227 000	5 000	
50	70	14	50.05	69.5	6	4	0.6	54	67	67	54	43 300	148 000	5 000	
	78	22	50.05	77.5	11	5.5	1	55	74	73	56	84 300	232 000	4 500	
55	78	16	55.05	77.5	6	5	0.6	59	75	75	60	51 700	192 000	4 500	
	90	25	55.05	89.5	11	7	1	63	85	84	63	108 000	332 000	4 000	
60	85	17	60.05	84.5	7.5	4.75	1	65	81	81	66	64 600	224 000	4 000	
	95	26	60.05	94.5	11	7.5	1	68	90	89	68	106 000	332 000	4 000	
	130	26	60.05	129.5	10	8	1.5	79	119	119	80	158 000	634 000	3 000	
65	90	18	65.05	89.5	7.5	5.25	1	70	86	86	71	68 300	247 000	4 000	
	100	27	65.05	99.5	11	8	1	73	95	94	73	116 000	379 000	3 500	

F
 NTB
 AS
 AZK
 WS-GS

THRUST BEARINGS

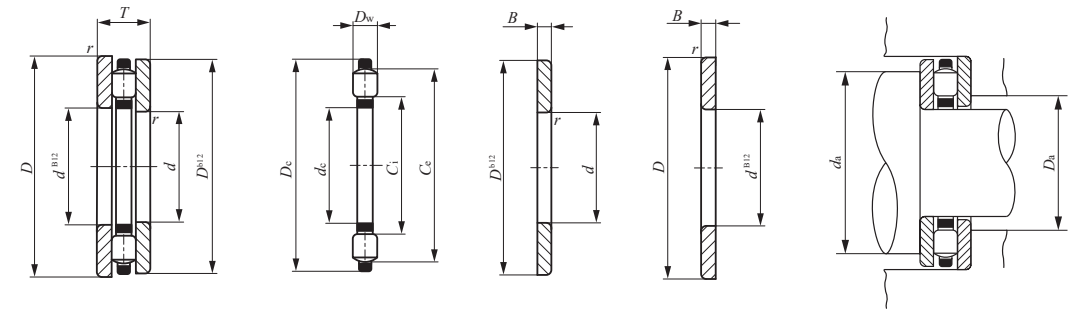
Thrust Roller Bearings



Shaft dia. 70 – 130mm

Shaft dia. mm	Identification number						
	Thrust roller bearing	Mass (Ref.) g	Thrust roller bearing	Mass (Ref.) g	Inner ring	Outer ring	Mass (Ref.) g
70	AZ 709518	420	AZK 70957.5	156	WS 7095	GS 7095	132
	AZ 7010527	905	AZK 7010511	325	WS 70105	GS 70105	290
	AZ 7014026	2 250	AZK 7014010	890	WS 70140	GS 70140	680
75	AZ 7510019	465	AZK 751007.5	159	WS 75100	GS 75100	153
	AZ 7511027	960	AZK 7511011	340	WS 75110	GS 75110	310
80	AZ 8010519	495	AZK 801057.5	171	WS 80105	GS 80105	162
	AZ 8011528	1 060	AZK 8011511	370	WS 80115	GS 80115	345
	AZ 8015026	2 500	AZK 8015010	920	WS 80150	GS 80150	790
85	AZ 8511019	530	AZK 851107.5	190	WS 85110	GS 85110	170
	AZ 8512531	1 460	AZK 8512512	510	WS 85125	GS 85125	475
90	AZ 9012022	790	AZK 901209	290	WS 90120	GS 90120	250
	AZ 9013535	2 040	AZK 9013514	750	WS 90135	GS 90135	645
	AZ 9016026	2 710	AZK 9016010	1 000	WS 90160	GS 90160	855
100	AZ 10013525	1 190	AZK 10013511	490	WS 100135	GS 100135	350
	AZ 10015038	2 720	AZK 10015015	980	WS 100150	GS 100150	870
	AZ 10019039	5 960	AZK 10019015	2 120	WS 100190	GS 100190	1 920
110	AZ 11014525	1 350	AZK 11014511	590	WS 110145	GS 110145	380
	AZ 11016040	3 220	AZK 11016017	1 320	WS 110160	GS 110160	950
	AZ 11020039	6 400	AZK 11020015	2 280	WS 110200	GS 110200	2 060
120	AZ 12015525	1 450	AZK 12015511	630	WS 120155	GS 120155	410
	AZ 12017542	4 020	AZK 12017518	1 640	WS 120175	GS 120175	1 190
	AZ 12022039	7 730	AZK 12022015	2 730	WS 120220	GS 120220	2 500
130	AZ 13017030	2 180	AZK 13017012	860	WS 130170	GS 130170	660
	AZ 13018542	4 300	AZK 13018518	1 760	WS 130185	GS 130185	1 270
	AZ 13023039	8 240	AZK 13023015	2 940	WS 130230	GS 130230	2 650

Notes⁽¹⁾ Minimum allowable value of chamfer dimension *r*
⁽²⁾ Allowable rotational speed applies to oil lubrication. For grease lubrication, a maximum of 25% of this value is allowable.



AZ AZK WS GS

Boundary dimensions mm											Standard mounting dimensions mm		Basic dynamic load rating	Basic static load rating	Allowable rotational speed ⁽²⁾
<i>d</i>	<i>D</i>	<i>T</i>	<i>d_c</i>	<i>D_c</i>	<i>D_w</i>	<i>B</i>	<i>r_{s min}</i> ⁽¹⁾	<i>C_i</i>	<i>C_e</i>	<i>d_a</i> Min.	<i>D_a</i> Max.	<i>C</i> N	<i>C₀</i> N	min ⁻¹	
70	95	18	70.05	94.5	7.5	5.25	1	75	91	91	76	72 000	269 000	3 500	
70	105	27	70.05	104.5	11	8	1	78	100	99	78	114 000	379 000	3 500	
70	140	26	70.05	139.5	10	8	1.1	89	129	129	90	169 000	713 000	3 000	
75	100	19	75.05	99.5	7.5	5.75	1	80	96	96	81	71 100	269 000	3 500	
75	110	27	75.05	109.5	11	8	1	83	105	104	83	123 000	427 000	3 000	
80	105	19	80.05	104.5	7.5	5.75	1	85	101	101	86	74 500	292 000	3 000	
80	115	28	80.05	114.5	11	8.5	1	88	110	109	88	122 000	427 000	3 000	
80	150	26	80.05	149.5	10	8	1.5	99	139	139	100	180 000	792 000	2 500	
85	110	19	85.05	109.5	7.5	5.75	1	90	106	106	91	77 800	314 000	3 000	
85	125	31	85.05	124.5	12	9.5	1	95	119	118	95	145 000	513 000	3 000	
90	120	22	90.05	119.5	9	6.5	1	97	116	115	97	99 700	390 000	3 000	
90	135	35	90.05	134.5	14	10.5	1.1	100	129	128	101	181 000	626 000	2 500	
90	160	26	90.05	159.5	10	8	1.5	109	149	149	110	189 000	871 000	2 500	
100	135	25	100.05	134.5	11	7	1	108	130	129	108	136 000	522 000	2 500	
100	150	38	100.05	149.5	15	11.5	1.1	112	143	142	113	219 000	796 000	2 500	
100	190	39	100.1	189.3	15	12	1.5	119	179	177	120	333 000	1 420 000	2 000	
110	145	25	110.1	144.5	11	7	1	118	140	139	118	142 000	569 000	2 500	
110	160	40	110.1	159.5	17	11.5	1.1	120	154	153	121	282 000	1 030 000	2 000	
110	200	39	110.1	199.3	15	12	2	129	188	187	130	388 000	1 770 000	2 000	
120	155	25	120.1	154.5	11	7	1	128	150	149	128	149 000	617 000	2 000	
120	175	42	120.1	174.5	18	12	1.1	132	168	167	133	313 000	1 160 000	2 000	
120	220	39	120.1	219	15	12	2.1	141	207	206	142	415 000	1 980 000	1 800	
130	170	30	130.1	169.5	12	9	1	140	164	163	140	176 000	741 000	2 000	
130	185	42	130.1	184.5	18	12	1.5	142	178	177	143	333 000	1 290 000	1 900	
130	230	39	130.1	229	15	12	2.1	151	217	216	152	440 000	2 180 000	1 700	

F
 NTB
 AS
 AZK
 WS·GS

THRUST BEARINGS

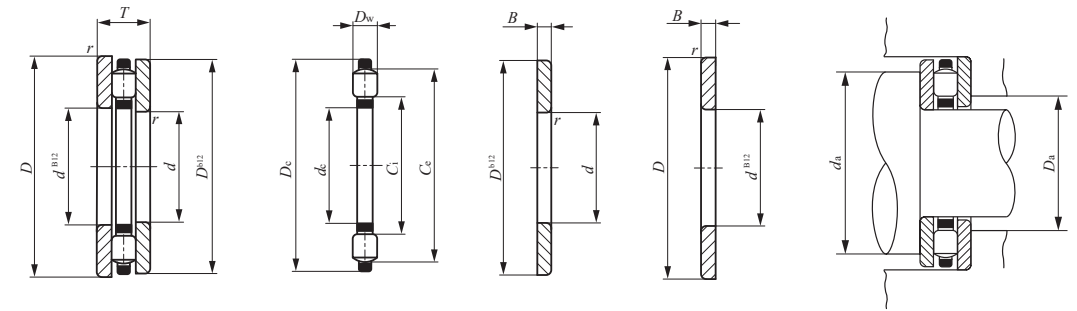
Thrust Roller Bearings



Shaft dia. 140 – 280mm

Shaft dia. mm	Identification number						
	Thrust roller bearing	Mass (Ref.) g	Thrust roller bearing	Mass (Ref.) g	Inner ring	Outer ring	Mass (Ref.) g
140	AZ 14018031	2 410	AZK 14018012	920	WS 140180	GS 140180	745
	AZ 14019542	4 560	AZK 14019518	1 860	WS 140195	GS 140195	1 350
	AZ 14024039	8 680	AZK 14024015	3 100	WS 140240	GS 140240	2 790
150	AZ 15019031	2 560	AZK 15019012	980	WS 150190	GS 150190	790
	AZ 15020542	4 840	AZK 15020518	1 980	WS 150205	GS 150205	1 430
	AZ 15025039	9 140	AZK 15025015	3 260	WS 150250	GS 150250	2 940
160	AZ 16020031	2 710	AZK 16020012	1 030	WS 160200	GS 160200	840
	AZ 16027039	10 800	AZK 16027015	3 840	WS 160270	GS 160270	3 480
170	AZ 17023045	6 220	AZK 17023019	2 420	WS 170230	GS 170230	1 900
	AZ 17028039	11 300	AZK 17028015	4 020	WS 170280	GS 170280	3 640
180	AZ 18024045	6 540	AZK 18024019	2 540	WS 180240	GS 180240	2 000
	AZ 18031039	14 600	AZK 18031015	5 200	WS 180310	GS 180310	4 700
190	AZ 19025548	8 060	AZK 19025520	3 100	WS 190255	GS 190255	2 480
	AZ 19032039	15 000	AZK 19032015	5 280	WS 190320	GS 190320	4 860
200	AZ 20026548	8 430	AZK 20026520	3 250	WS 200265	GS 200265	2 590
	AZ 20034039	17 200	AZK 20034015	6 120	WS 200340	GS 200340	5 540
220	AZ 22029050	10 400	AZK 22029022	4 280	WS 220290	GS 220290	3 060
	AZ 22036052	24 000	AZK 22036020	8 000	WS 220360	GS 220360	8 000
240	AZ 24031554	13 200	AZK 24031524	5 520	WS 240315	GS 240315	3 840
	AZ 24038052	26 500	AZK 24038020	9 440	WS 240380	GS 240380	8 530
260	AZ 26034055	15 400	AZK 26034025	6 600	WS 260340	GS 260340	4 400
	AZ 26042080	51 600	AZK 26042030	18 200	WS 260420	GS 260420	16 700
280	AZ 28044080	54 600	AZK 28044030	19 200	WS 280440	GS 280440	17 700

Notes⁽¹⁾ Minimum allowable value of chamfer dimension r
⁽²⁾ Allowable rotational speed applies to oil lubrication. For grease lubrication, a maximum of 25% of this value is allowable.



AZ AZK WS GS

Boundary dimensions mm											Standard mounting dimensions mm		Basic dynamic load rating C N	Basic static load rating C ₀ N	Allowable rotational speed ⁽²⁾ min ⁻¹
d	D	T	d _c	D _c	D _w	B	r _{s min} ⁽¹⁾	C _i	C _c	d _a Min.	D _a Max.				
140	180	31	140.1	179.5	12	9.5	1	150	174	173	150	184 000	798 000	1 900	
140	195	42	140.1	194.5	18	12	1.5	152	188	187	153	353 000	1 420 000	1 800	
140	240	39	140.1	239	15	12	2.1	161	227	226	162	435 000	2 180 000	1 600	
150	190	31	150.1	189.5	12	9.5	1	160	184	183	160	181 000	798 000	1 800	
150	205	42	150.1	204.5	18	12	1.5	162	198	197	163	349 000	1 420 000	1 700	
150	250	39	150.1	249	15	12	2.1	171	237	236	172	459 000	2 380 000	1 500	
160	200	31	160.1	199.5	12	9.5	1	170	194	193	170	189 000	855 000	1 700	
160	270	39	160.1	269	15	12	3	183	256	255	184	519 000	2 850 000	1 400	
170	230	45	170.1	229	19	13	1.5	183	221	220	184	406 000	1 730 000	1 500	
170	280	39	170.1	279	15	12	3	193	266	265	194	543 000	3 070 000	1 300	
180	240	45	180.1	239	19	13	1.5	193	231	230	194	426 000	1 870 000	1 400	
180	310	39	180.1	308	15	12	3	204	294	293	205	619 000	3 710 000	1 200	
190	255	48	190.1	254	20	14	2	205	245	244	206	470 000	2 080 000	1 300	
190	320	39	190.1	318	15	12	4	214	304	303	215	647 000	3 980 000	1 200	
200	265	48	200.15	264	20	14	2	215	255	254	216	465 000	2 080 000	1 300	
200	340	39	200.15	338	15	12	4	227	323	322	228	710 000	4 580 000	1 100	
220	290	50	220.15	289	22	14	2	236	280	278	237	557 000	2 530 000	1 300	
220	360	52	220.15	358	20	16	4	246	343	342	247	943 000	5 520 000	1 000	
240	315	54	240.15	314	24	15	2	256	304	302	257	695 000	3 250 000	1 100	
240	380	52	240.15	378	20	16	4	266	363	362	267	977 000	5 910 000	1 000	
260	340	55	260.15	339	25	15	2.1	278	328	326	279	739 000	3 510 000	1 000	
260	420	80	260.15	418	30	25	5	289	402	400	291	1 430 000	7 490 000	900	
280	440	80	280.15	438	30	25	5	309	422	420	311	1 420 000	7 490 000	800	

F
 NTB
 AS
 AZK
 WS-GS

COMBINED TYPE NEEDLE ROLLER BEARINGS

- Needle Roller Bearings with Thrust Ball Bearing
- Needle Roller Bearings with Thrust Roller Bearing
- Needle Roller Bearings with Angular Contact Ball Bearing
- Needle Roller Bearings with Three-point Contact Ball Bearing



Structure and Features

IKO Combined Type Needle Roller Bearings are combinations of a radial bearing and a thrust bearing. Caged needle roller bearings are used as radial bearings and thrust ball bearings or thrust roller bearings are used as thrust bearings. They are compact and very economical, and can be subjected to radial loads and axial loads simultaneously. They are widely used for machine tools, textile machinery, and industrial machinery.

Types

The types of Combined Type Needle Roller Bearings shown in Table 1 are available.

Table 1.1 Type of bearing

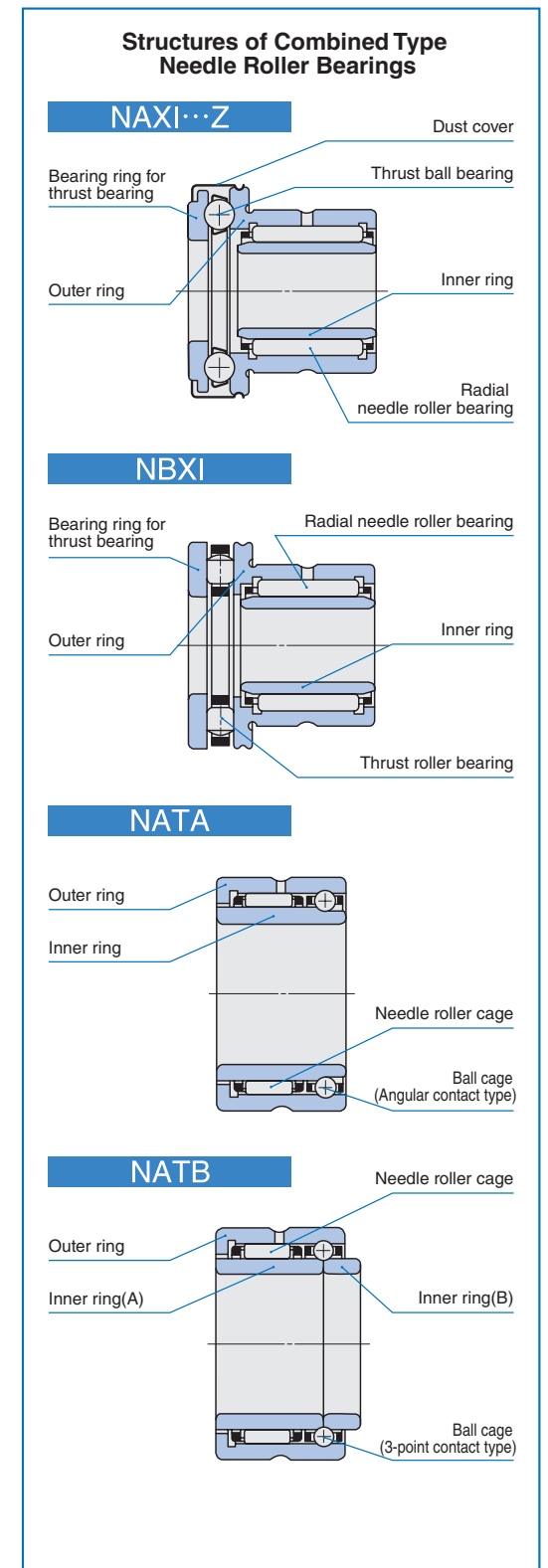
Type	Combined with thrust ball bearing		Combined with thrust roller bearing	
	Without inner ring	With inner ring	Without inner ring	With inner ring
—	NAX	NAXI	NBX	NBXI
With dust cover	NAX ... Z	NAXI ... Z	NBX ... Z	NBXI ... Z

Table 1.2 Type of bearing

Type	Combined with angular contact ball bearing	Combined with three-point contact ball bearing
Model code	NATA	NATB

Needle Roller Bearings with Thrust Ball Bearing

In this series, needle roller bearings are combined with thrust ball bearings to receive thrust loads. In bearings with a dust cover, the dust cover is formed from a thin steel plate and fixed to a groove cut on the outer cylindrical surface of the outer ring collar. The cover forms a labyrinth with the thrust raceway ring, and is therefore effective in preventing leakage of grease and penetration of dust and dirt. In the case of bearings without an inner ring, the tolerances of roller set bore diameter F_w are shown in Table 14 on page A33. Therefore, the required radial internal clearances can be selected by combining the bearings with shafts that have been heat-treated and finished by grinding as shown in Table 23 on page A42 and Table 26 on page A44.



G

NAX
NBX
NATA
NATB

Needle Roller Bearings with Thrust Roller Bearing

In this series, needle roller bearings are combined with thrust roller bearings to receive thrust loads. Their axial load ratings are greater than those of bearings that are combined with thrust ball bearings. Also, elastic deformation of the rolling contact surfaces under load is minimal. Furthermore, the thrust bearing section is finished to high accuracy, and therefore high rotational accuracy is obtained in the case of both vertical and horizontal shafts. Like the needle roller bearings with thrust ball bearing, this series also includes bearings with a dust cover and bearings with an inner ring.

Needle Roller Bearings with Angular Contact Ball Bearing

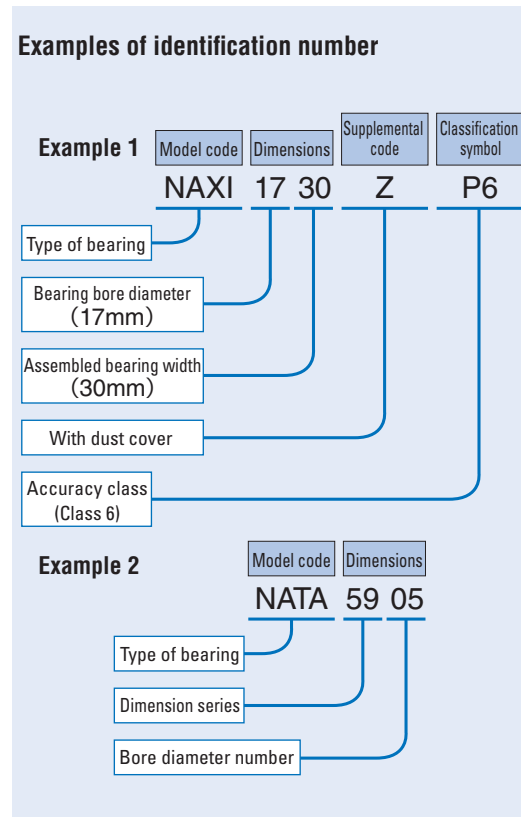
In this series, caged needle roller bearings are combined with angular contact ball bearings to receive thrust loads. These bearings conform to the international dimension series #59, which is based on the ISO Standard. They can withstand heavy radial loads and unidirectional axial loads simultaneously. When the axial load exceeds 25% of the radial load, the radial load will be induced in the angular contact ball bearing, and bearing life will be affected. The relationship between the two loads must therefore be taken into careful consideration.

Needle Roller Bearings with Three-point Contact Ball Bearing

These bearings can withstand heavy radial loads and bi-directional axial loads at the same time during high-speed rotation. Since the non-interchangeable inner rings are separated at the center of the ball raceway surface, they must be firmly tightened against the shaft in the axial direction. The axial clearance of this bearing is 0.1 ~ 0.3 mm, and like NATA59, the axial load should not exceed 25% of the radial load.

Identification Number

The identification number of Combined Type Needle Roller Bearings consists of a model code, dimensions, any supplemental codes and a classification symbol. Some examples are shown below.



Accuracy

Dimensional accuracy and rotational accuracy of Combined Type Needle Roller Bearings are based on Table 2 below and Tables 12 and 13 on page A31. The tolerances for the smallest single roller set bore diameter of bearings without inner ring are based on Table 14 on page A33. Thickness variations of thrust rings of NAX(I) and NBX(I) are based on Table 2.4 on page F5. Bore diameter of the small width inner ring of NATB59 is made for a transition fit with k5 tolerance shaft.

Table 2 Tolerances

Type of bearing	Item	Dimension	Dimension symbol	Tolerance
NAX(I) ⁽¹⁾ NBX(I) ⁽¹⁾	Bore dia. of bearing ring for thrust bearing		d_i	E7
	Assembled bearing width		L	0 - 0.25
	Bearing height of thrust bearing		H	0 - 0.20
NATB59	Width of inner ring		B	0 - 0.3

Note⁽¹⁾ Also applicable to bearings with dust cover

Clearance

Combined Type Needle Roller Bearings are manufactured to have the radial internal clearance CN shown in Table 18 on page A37.

Fit

The recommended fits for Combined Type Needle Roller Bearings are shown in Table 3.

Table 3 Recommended fits

Type of bearing	Item	Tolerance class		
		Shaft		Housing bore
		Without inner ring	With inner ring	
NAX(I) ⁽¹⁾ NBX(I) ⁽¹⁾		h5, k5	k5	K6, M6
NATA59 NATB59		—	k5 ⁽²⁾	M6 ⁽²⁾

Notes⁽¹⁾ The housing bore for the thrust bearing must be machined to be more than 0.5 mm larger than the outside diameters D_1 and D_2 to ensure that it does not incur radial loads.
⁽²⁾ If the fit is made tighter than specified in this table, radial loads will act upon the thrust bearing, limiting its function.

Lubrication

Grease is not prepacked in Combined Type Needle Roller Bearings, so perform proper lubrication for use. Operating without lubrication will increase the wear of the rolling contact surfaces and shorten the bearing life.

Oil Hole

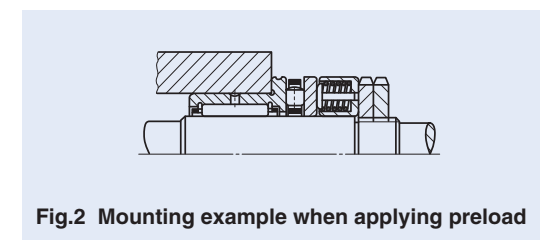
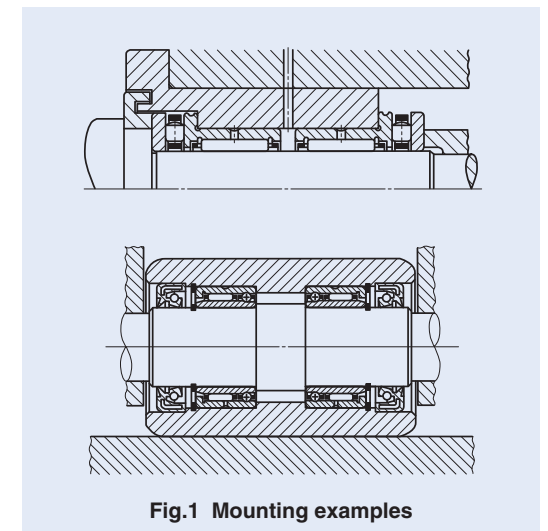
The outer ring of Combined Type Needle Roller Bearings has an oil groove and an oil hole. When outer rings with multiple oil holes or inner rings with oil hole(s) are required, please contact IKO.

Rating Life

In Combined Type Needle Roller Bearings, caged needle roller bearings are subjected to radial loads while thrust bearings receive axial loads. Therefore, it is necessary to calculate their lives respectively (page A17).

Mounting

Fig.1 shows mounting examples of Combined Type Needle Roller Bearings. When applying preload to the NAX and NBX models, it is recommended that thrust raceway rings are not tightened directly with nuts, but are tightened using springs as shown in Fig. 2. Mounting two NATA models symmetrically allows them to be subjected to two-way axial loads. When mounting these models, an axial clearance of 0.2 ~ 0.3 mm should be provided in the angular contact ball bearings so that radial loads are not applied to the angular contact ball bearings. Dimensions related to mounting should be based on the table of dimensions.

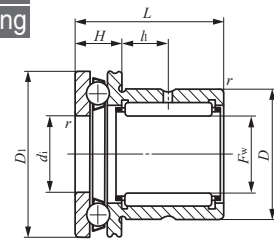


G
NAX
NBX
NATA
NATB

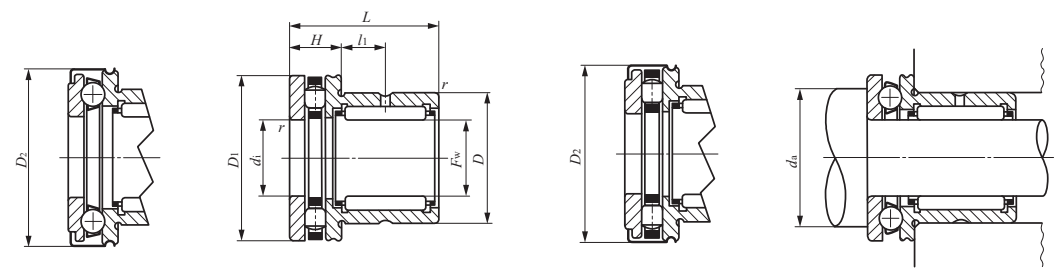
COMBINED TYPE NEEDLE ROLLER BEARINGS

Needle Roller Bearings with Thrust Ball Bearing
Needle Roller Bearings with Thrust Roller Bearing

Without Inner Ring
Without Inner Ring



NAX



NAX...Z

NBX

NBX...Z

Shaft dia. 10 – 70mm

Shaft dia. mm	Identification number							
		Mass (Ref.) g	With dust cover	Mass (Ref.) g		Mass (Ref.) g	With dust cover	Mass (Ref.) g
10	NAX 1023	38.5	NAX 1023Z	40	—	—	—	—
12	NAX 1223	43.5	NAX 1223Z	45.5	—	—	—	—
15	NAX 1523	47.5	NAX 1523Z	48.5	NBX 1523	54	NBX 1523Z	55
17	NAX 1725	54	NAX 1725Z	56	—	—	—	—
20	NAX 2030	85.5	NAX 2030Z	89	—	—	—	—
25	NAX 2530	131	NAX 2530Z	135	—	—	—	—
30	NAX 3030	145	NAX 3030Z	151	—	—	—	—
35	NAX 3530	169	NAX 3530Z	176	—	—	—	—
40	NAX 4032	219	NAX 4032Z	227	—	—	—	—
45	NAX 4532	264	NAX 4532Z	273	—	—	—	—
50	NAX 5035	287	NAX 5035Z	297	—	—	—	—
60	NAX 6040	417	NAX 6040Z	454	—	—	—	—
70	NAX 7040	555	NAX 7040Z	606	—	—	—	—

Notes⁽¹⁾ Minimum allowable value of chamfer dimension *r*
⁽²⁾ Allowable rotational speed applies to oil lubrication. For grease lubrication, a maximum of 70% of this value is allowable in the NAX series, and a maximum of 25% of this value is allowable in the NBX series.
 Remarks1. The outer ring has an oil groove and an oil hole.
 2. No grease is prepacked. Perform proper lubrication.

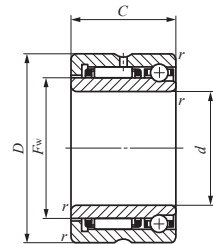
F _w	Boundary dimensions mm									Standard mounting dimension d _a Min. mm	Basic dynamic load rating C		Basic static load rating C ₀		Allowable rotational speed ⁽²⁾ min ⁻¹
	D	D ₁	D ₂	L	H	l ₁	r _{s min} ⁽¹⁾	d _i	Radial N		Axial N	Radial N	Axial N		
10	19	24	25	23	9	6.5	0.3	10	18	8 230	10 000	9 190	11 100	9 500	
12	21	26	27	23	9	6.5	0.3	12	20	9 250	9 670	11 200	11 100	9 000	
15	24	28	29	23	9	6.5	0.3	15	23	12 300	9 930	14 900	12 200	8 500	
15	24	28	29	23	9	6.5	0.3	15	26	12 300	10 200	14 900	23 900	14 000	
17	26	30	31	25	9	8	0.3	17	25	12 900	10 800	16 300	14 500	8 500	
17	26	30	31	25	9	8	0.3	17	28	12 900	11 400	16 300	28 600	13 000	
20	30	35	36	30	10	10.5	0.3	20	29	17 600	14 200	25 400	19 700	7 500	
20	30	35	36	30	10	10.5	0.3	20	33	17 600	19 000	25 400	48 700	11 000	
25	37	42	43	30	11	9.5	0.6	25	35	20 000	19 600	32 100	29 700	7 000	
25	37	42	43	30	11	9.5	0.6	25	40	20 000	22 700	32 100	60 700	9 000	
30	42	47	48	30	11	9.5	0.6	30	40	25 100	20 400	40 100	33 600	6 500	
30	42	47	48	30	11	9.5	0.6	30	45	25 100	27 400	40 100	81 000	8 000	
35	47	52	53	30	12	9	0.6	35	45	26 900	21 200	46 200	37 600	6 000	
35	47	52	53	30	12	9	0.6	35	50	26 900	29 100	46 200	91 100	7 000	
40	52	60	61	32	13	10	0.6	40	52	29 400	26 900	54 100	50 000	5 500	
40	52	60	61	32	13	10	0.6	40	57	29 400	41 700	54 100	133 000	6 000	
45	58	65	66.5	32	14	9	0.6	45	57	31 000	27 900	60 200	55 100	5 000	
45	58	65	66.5	32	14	9	0.6	45	62	31 000	40 800	60 200	133 000	5 500	
50	62	70	71.5	35	14	10	0.6	50	62	42 200	28 800	83 400	60 100	4 500	
50	62	70	71.5	35	14	10	0.6	50	67	42 200	43 300	83 400	148 000	5 000	
60	72	85	86.5	40	17	12	1	60	75	47 500	41 400	103 000	89 700	4 000	
60	72	85	86.5	40	17	12	1	60	82	47 500	64 600	103 000	224 000	4 000	
70	85	95	96.5	40	18	11	1	70	85	55 500	43 100	120 000	101 000	3 500	

G

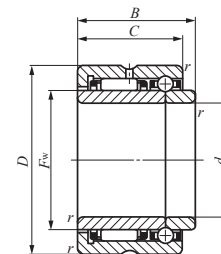
NAX
NBX
NATA
NATB

COMBINED TYPE NEEDLE ROLLER BEARINGS

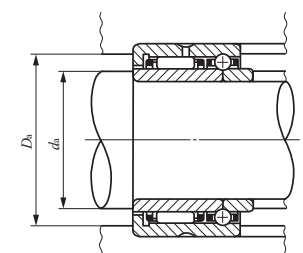
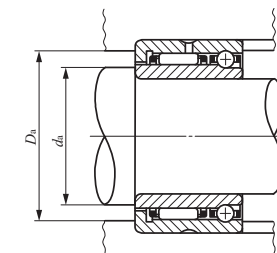
Needle Roller Bearings with Angular Contact Ball Bearing
 Needle Roller Bearings with Three-point Contact Ball Bearing



NATA59



NATB59



Shaft dia. 15 – 70mm

Shaft dia. mm	Identification number				Boundary dimensions mm					
	Angular contact type	Mass (Ref.) g	Three-point contact type	Mass (Ref.) g	<i>d</i>	<i>D</i>	<i>C</i>	<i>B</i>	<i>r_{s min}</i> ⁽¹⁾	<i>F_w</i>
15	NATA 5902	50.5	NATB 5902	53	15	28	18	20	0.3	20
17	NATA 5903	55.5	NATB 5903	58.5	17	30	18	20	0.3	22
20	NATA 5904	111	NATB 5904	115	20	37	23	25	0.3	25
25	NATA 5905	131	NATB 5905	136	25	42	23	25	0.3	30
30	NATA 5906	151	NATB 5906	157	30	47	23	25	0.3	35
35	NATA 5907	250	NATB 5907	260	35	55	27	30	0.6	42
40	NATA 5908	355	NATB 5908	375	40	62	30	34	0.6	48
45	NATA 5909	410	NATB 5909	435	45	68	30	34	0.6	55
50	NATA 5910	420	NATB 5910	445	50	72	30	34	0.6	58
55	NATA 5911	585	NATB 5911	615	55	80	34	38	1	63
60	NATA 5912	625	NATB 5912	660	60	85	34	38	1	68
65	NATA 5913	665	NATB 5913	710	65	90	34	38	1	75
70	NATA 5914	1 070	NATB 5914	1 130	70	100	40	45	1	80

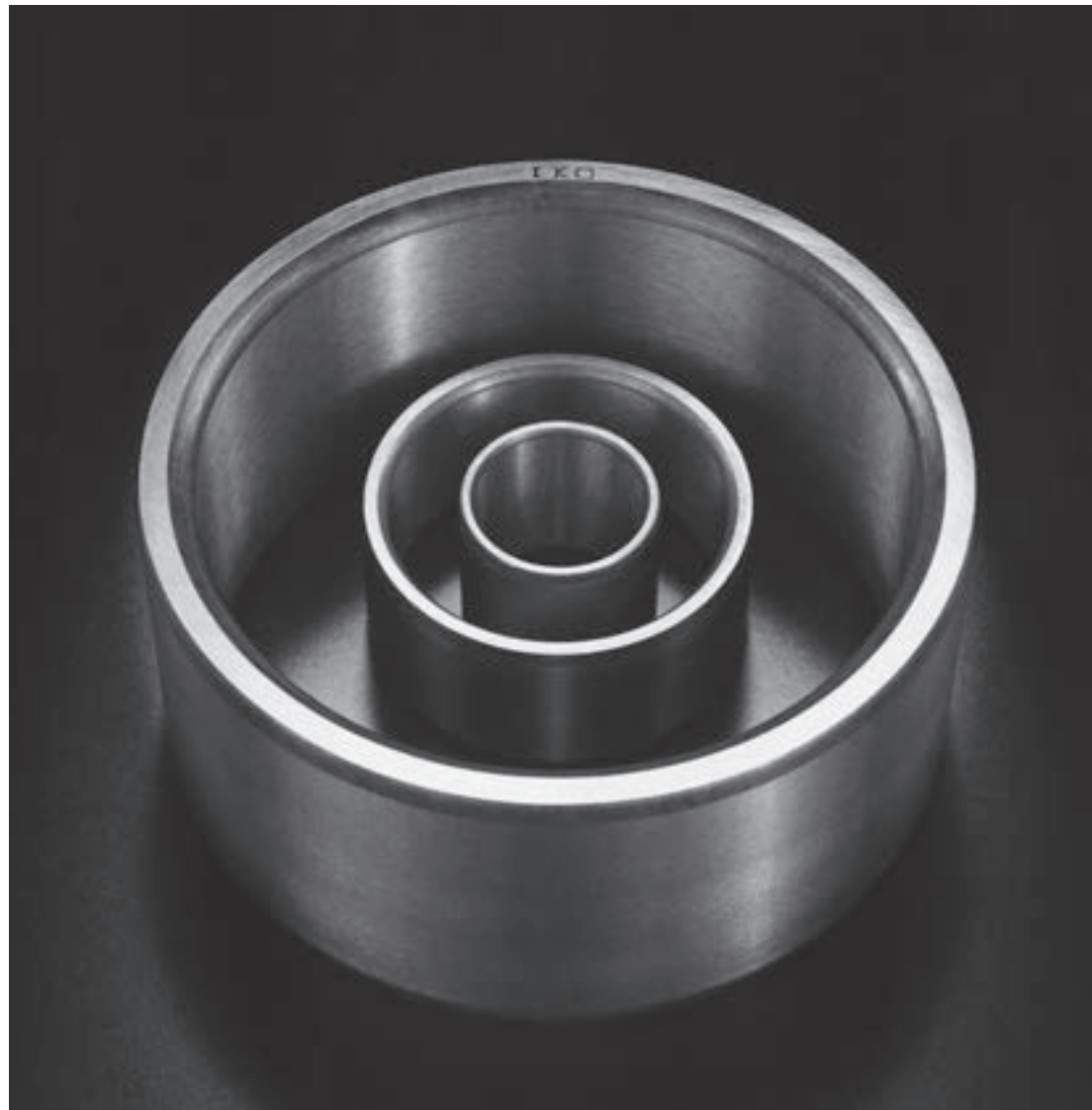
Notes⁽¹⁾ Minimum allowable value of chamfer dimension *r*
⁽²⁾ Allowable rotational speed applies to oil lubrication. For grease lubrication, a maximum of 60% of this value is allowable.
 Remarks1. The outer ring has an oil groove and an oil hole.
 2. No grease is prepacked. Perform proper lubrication.

Standard mounting dimensions mm		Basic dynamic load rating <i>C</i>		Basic static load rating <i>C₀</i>		Allowable rotational speed ⁽²⁾ min ⁻¹
<i>d_a</i> Min.	<i>D_a</i> Max.	Radial N	Axial N	Radial N	Axial N	
17	26	7 710	1 900	10 200	2 920	20 000
19	28	8 220	2 050	11 500	3 340	18 000
22	35	14 300	3 810	18 400	6 110	16 000
27	40	15 800	4 300	22 100	7 520	13 000
32	45	17 700	4 550	26 800	8 460	11 000
39	51	24 000	4 890	42 100	9 870	9 500
44	58	30 600	5 350	60 400	11 800	8 500
49	64	32 600	5 450	68 500	12 700	7 000
54	68	33 600	5 660	72 500	13 600	7 000
60	75	39 500	10 400	74 400	24 700	6 500
65	80	41 800	10 700	82 200	26 700	6 000
70	85	43 800	11 000	90 200	28 700	5 500
75	95	56 400	13 500	127 000	35 000	5 000

G
 NAX
 NBX
 NATA
 NATB

INNER RINGS

- Inner Rings for Shell Type Needle Roller Bearings
- Inner Rings for General Usage



Structure and Features

IKO Inner Rings are heat-treated and finished by grinding to a high degree of accuracy. In the case of needle roller bearings, normally, the shafts are heat-treated and finished by grinding, and used as the raceway surfaces. However, when it is impossible to make shaft surfaces according to the specified surface hardness or surface roughness, inner rings are used.

Inner rings include those for Shell Type Needle Roller Bearings and those for general use and are available in a variety of dimensions. When shafts move axially or seals are used adjacent to bearings, wide inner rings can be selected.

Inner rings can also be used economically as bushings without requiring any additional machining.

Types

For Inner Rings, the types shown in Table 1 are available.

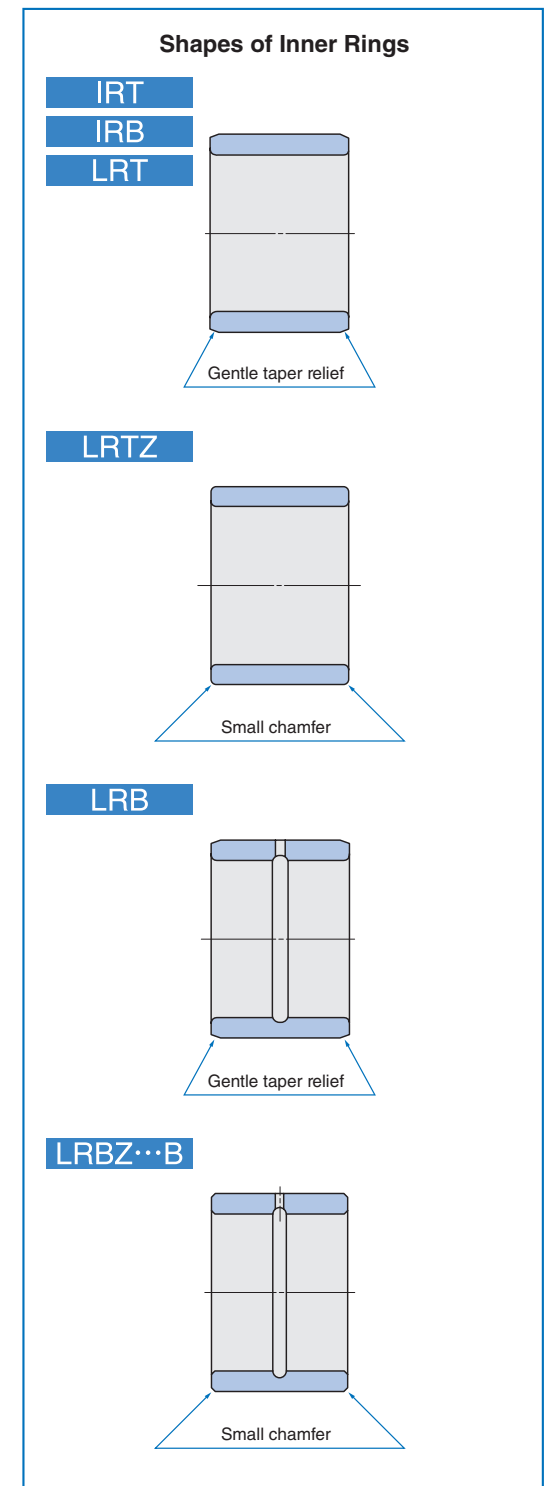
Table 1.1 Inner Rings for Shell Type Needle Roller Bearings

Series		Model codes of assembled bearings
Metric series	IRT	TA...Z, TLA...Z TAM, TLAM, YT, YTL
Inch series	IRB	BA...Z, BHA...Z BAM, BHAM, YB, YBH

Remark For Inner Rings for Shell Type Needle Roller Bearings with Seal, please consult IKO.

Table 1.2 Inner Rings for General Usage

Series		Model codes of assembled bearings
Metric series	LRT	RNA 49, RNA 69 RNA 48, TAF, TR RNAF, NAX, NBX
	LRTZ	RNA 49...UU, RNA 69...UU GTR
Inch series	LRB	BR
	LRBZ...B	BR...UU

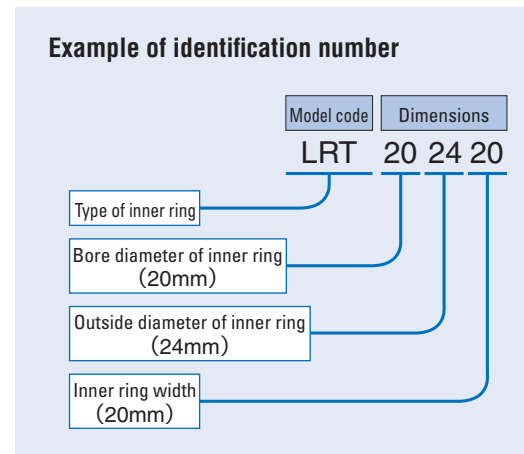


H

IRT
IRB
LRT
LRB

Identification number

The identification number of Inner Rings consists of a model code and dimensions. An example is shown below.



Accuracy

Dimensional accuracy of Inner Rings is based on Table 2. Inner Rings for Shell Type Needle Roller Bearings are manufactured so that exact radial internal clearances can be obtained when assembled with Shell Type Needle Roller Bearings. Inner Rings for General Usage produce CN clearance when used in the assembled bearings shown in Table 1.2. LRB and LRBZ ... B models produce the radial internal clearances shown in Table 4 on page D5.

When clearances other than CN clearance or accuracy other than Class 0 are required, please consult IKO.

Table 2 Tolerances for inner ring

Model code	Tolerance
IRT LRT, LRTZ	JIS Class 0 (See the table 12, page A31)
IRB	Based on Table 3
LRB LRBZ ... B	Based on Table 4

Remark Tolerances of outside diameter of inner ring are based on Table 5.

Table 3 Tolerances of IRB

unit: μm

Nominal inside diameter of inner ring mm	Δ _{dmp} Single plane mean bore diameter deviation		Δ _{BS} Deviation of a single inner ring width		K _{ia} Radial runout of assembled bearing inner ring	
	High	Low	High	Low		
						Over
2.5	10	0	-13	0	-250	10
10	18	0	-13	0	-250	10
18	30	0	-13	0	-250	13
30	50	0	-13	0	-250	15
50	80	0	-13	0	-250	20

Table 4 Tolerances of LRB,LRBZ...B

unit: μm

Nominal inside diameter of inner ring mm	Δ _{dmp} Single plane mean bore diameter deviation		Δ _{BS} Deviation of a single inner ring width		K _{ia} Radial runout of assembled bearing inner ring	
	High	Low	High	Low		
						Over
-	19.050	0	-10	0	-130	10
19.050	30.162	0	-13	0	-130	13
30.162	50.800	0	-13	0	-130	15
50.800	82.550	0	-15	0	-130	20
82.550	120.650	0	-20	0	-130	25

Table 6 Tolerances of outside diameters for LRT and LRTZ (When the clearance is CN clearance)

unit: μm

d Bore diameter of inner ring mm	F Outside diameter of inner ring mm	F Outside diameter of inner ring mm																								d Bore diameter of inner ring mm		
		3 < F ≤ 6		6 < F ≤ 10		10 < F ≤ 18		18 < F ≤ 30		30 < F ≤ 50		50 < F ≤ 80		80 < F ≤ 120		120 < F ≤ 180		180 < F ≤ 250		250 < F ≤ 315		315 < F ≤ 400		400 < F ≤ 500		Over	Incl.	
		High	Low	High	Low	High	Low	High	Low	High	Low	High	Low	High	Low	High	Low	High	Low	High	Low	High	Low	High	Low			
-	24	-10	-27	-7	-23	-4	-18	0	-12																		-	24
24	30							0	-12	+5	-4																24	30
30	40							0	-12	0	-9																30	40
40	50									-5	-19																40	50
50	65											0	-11														50	65
65	80																										65	80
80	100																										80	100
100	120																										100	120
120	140																										120	140
140	160																										140	160
160	180																										160	180
180	200																										180	200
200	225																										200	225
225	250																										225	250
250	280																										250	280
280	315																										280	315
315	355																										315	355
355	400																										355	400
400	450																										400	450
450	500																										450	500

Table 5 Tolerances of outside diameter of inner ring unit: μm

Model code	Tolerance
IRT	g5
IRB	0 ~ -13
LRT, LRTZ	Based on Table 6
LRB, LRBZ ... B	Based on Table 7

Table 7 Tolerances of outside diameters of LRB and LRBZ ... B unit: μm

Nominal outside diameter of inner ring mm	Tolerance			
	Over	Incl.	High	Low
-	18.034	25.908	-13	-23
18.034	25.908	30.226	-18	-30
25.908	30.226	35.052	-23	-36
30.226	35.052	50.038	-23	-38
35.052	50.038	80.010	-25	-41
50.038	80.010	100.076	-28	-46
80.010	100.076	102.108	-32	-56
100.076	102.108		-37	-66

Fit

The recommended fits between Inner Rings and shafts are shown in Table 22 on page A42.

Oil Hole

The number of oil holes is shown in Table 8. When Inner Rings with an oil hole are especially required for a model without an oil hole, attach an "OH" to the end of the identification number when ordering.

Example: LRT 202420 OH

For Inner Rings with multiple oil holes, please consult IKO.

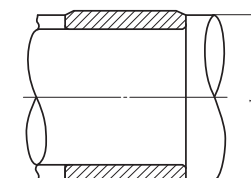
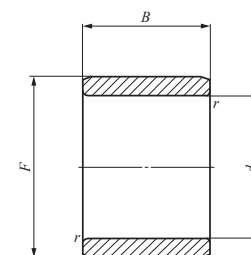
Table 8 Number of oil holes

Bearing type	Bore diameter of inner ring d mm	Number of oil holes	
		For Shell Type Needle Roller Bearings	For General Usage
Metric series IRT		0	
Inch series IRB		0	
Metric series LRT		0	
Metric series LRTZ		0	
Inch series	LRB	1	$d \leq 76.200$
		2	$76.200 < d$
	LRBZ ... B	1	

Remark Inner rings with an oil hole are provided with an oil groove.

INNER RINGS

Inner Rings for Shell Type Needle Roller Bearings



IRT

Shaft dia. 7 – 17mm

Shaft dia. mm	Identification number	Mass (Ref.) g	Boundary dimensions mm				Standard mounting dimension mm		Assembled bearings		
			<i>d</i>	<i>F</i>	<i>B</i>	$r_{s\ min}^{(1)}$	Min.	Max.	TA...Z (TAM)	TLA...Z (TLAM)	YT YTL
7	IRT 710	3.2	7	10	10.5	0.3	9	9.7	TA 1010Z	TLA 1010Z	—
	IRT 712	3.9	7	10	12.5	0.3	9	9.7	TA 1012Z	TLA 1012Z	—
	IRT 715	4.8	7	10	15.5	0.3	9	9.7	TA 1015Z	TLA 1015Z	—
8	IRT 810	5.1	8	12	10.5	0.3	10	11	—	TLA 1210Z	YTL 1210
	IRT 812	6	8	12	12.5	0.3	10	11	TA 1212Z	TLA 1212Z	YT 1212
	IRT 815	7.5	8	12	15.5	0.3	10	11	TA 1215Z	—	—
10	IRT 1012	5.2	10	13	12.5	0.3	12	12.7	—	TLA 1312Z	—
	IRT 1012-2	7.2	10	14	12.5	0.3	12	13	—	TLA 1412Z	—
	IRT 1016-2	9.6	10	14	16.5	0.3	12	13	TA 1416Z	TLA 1416Z	—
	IRT 1020-2	11.9	10	14	20.5	0.3	12	13	TA 1420Z	—	—
	IRT 1010-1	7.9	10	15	10.5	0.3	12	14	TA 1510Z	—	—
	IRT 1012-1	9.4	10	15	12.5	0.3	12	14	TA 1512Z	TLA 1512Z	—
	IRT 1015-1	11.7	10	15	15.5	0.3	12	14	TA 1515Z	—	—
	IRT 1020-1	15.5	10	15	20.5	0.3	12	14	TA 1520Z	—	—
	IRT 1025-1	19.3	10	15	25.5	0.3	12	14	TA 1525Z	—	—
12	IRT 1212	6.1	12	15	12.5	0.3	14	14.5	TA 1512Z	TLA 1512Z	—
	IRT 1216	8.1	12	15	16.5	0.3	14	14.5	—	TLA 1516Z	—
	IRT 1222	11	12	15	22.5	0.3	14	14.5	—	TLA 1522Z	—
	IRT 1212-1	8.5	12	16	12.5	0.3	14	15	—	TLA 1612Z	—
	IRT 1216-1	11.2	12	16	16.5	0.3	14	15	TA 1616Z	TLA 1616Z	—
	IRT 1220-1	13.9	12	16	20.5	0.3	14	15	TA 1620Z	—	—
	IRT 1222-1	15.2	12	16	22.5	0.3	14	15	—	TLA 1622Z	—
	IRT 1215-2	13.6	12	17	15.5	0.3	14	16	TA 1715Z	—	YT 1715
	IRT 1220-2	18	12	17	20.5	0.3	14	16	TA 1720Z	—	—
	IRT 1225-2	22.5	12	17	25.5	0.3	14	16	TA 1725Z	—	YT 1725
15	IRT 1512	7.5	15	18	12.5	0.3	17	17.5	—	TLA 1812Z	—
	IRT 1513	8.1	15	18	13.5	0.3	17	17.5	TA 1813Z	—	—

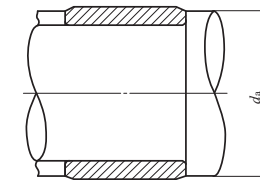
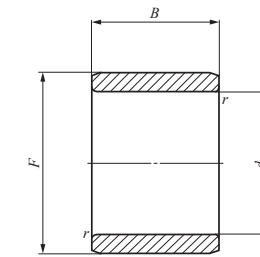
Note⁽¹⁾ Minimum allowable value of chamfer dimension *r*
Remark No oil hole is provided.

Shaft dia. mm	Identification number	Mass (Ref.) g	Boundary dimensions mm				Standard mounting dimension mm		Assembled bearings		
			<i>d</i>	<i>F</i>	<i>B</i>	$r_{s\ min}^{(1)}$	Min.	Max.	TA...Z (TAM)	TLA...Z (TLAM)	YT YTL
15	IRT 1515	9.3	15	18	15.5	0.3	17	17.5	TA 1815Z	—	—
	IRT 1516	9.9	15	18	16.5	0.3	17	17.5	—	TLA 1816Z	—
	IRT 1517	10.5	15	18	17.5	0.3	17	17.5	TA 1817Z	—	—
	IRT 1519	11.7	15	18	19.5	0.3	17	17.5	TA 1819Z	—	—
	IRT 1520	12.3	15	18	20.5	0.3	17	17.5	TA 1820Z	—	—
	IRT 1525	15.2	15	18	25.5	0.3	17	17.5	TA 1825Z	—	—
	IRT 1516-1	13.6	15	19	16.5	0.3	17	18	TA 1916Z	—	—
	IRT 1520-1	16.8	15	19	20.5	0.3	17	18	TA 1920Z	—	—
	IRT 1515-2	16.4	15	20	15.5	0.3	17	19	TA 2015Z	—	YT 2015
	IRT 1520-2	21.5	15	20	20.5	0.3	17	19	TA 2020Z	TLA 2020Z	YT 202820
	IRT 1525-2	27	15	20	25.5	0.3	17	19	TA 2025Z	—	YT 2025
	IRT 1530-2	32	15	20	30.5	0.3	17	19	TA 2030Z	TLA 2030Z	—
	17	IRT 1716	11.1	17	20	16.5	0.3	19	19.5	—	TLA 2016Z
IRT 1720		13.7	17	20	20.5	0.3	19	19.5	TA 2020Z	TLA 2020Z	YT 202820
IRT 1730		20.5	17	20	30.5	0.3	19	19.5	TA 2030Z	TLA 2030Z	—
IRT 1716-1		15.1	17	21	16.5	0.3	19	20	TA 2116Z	—	YT 2116
IRT 1720-1		18.8	17	21	20.5	0.3	19	20	TA 2120Z	—	YT 2120
IRT 1710-2		12.4	17	22	10.5	0.3	19	21	TA 2210Z	—	—
IRT 1715-2		18.3	17	22	15.5	0.3	19	21	TA 2215Z	—	—
IRT 1716-2		19.4	17	22	16.5	0.3	19	21	TA 223016Z	TLA 2216Z	YT 223016
IRT 1720-2		24	17	22	20.5	0.3	19	21	TA 2220Z	TLA 2220Z	YT 223020
IRT 1725-2		30	17	22	25.5	0.3	19	21	TA 223020Z	—	—
IRT 1730-2		36	17	22	30.5	0.3	19	21	TA 2225Z	—	—
									TA 2230Z	—	—

Note⁽¹⁾ Minimum allowable value of chamfer dimension *r*
Remark No oil hole is provided.

INNER RINGS

Inner Rings for Shell Type Needle Roller Bearings



IRT

Shaft dia. 20 – 45mm

Shaft dia. mm	Identification number	Mass (Ref.) g	Boundary dimensions mm				Standard mounting dimension mm		Assembled bearings		
			d	F	B	⁽¹⁾ r _{s min}	Min. d _a	Max. d _a	TA ... Z (TAM)	TLA ... Z (TLAM)	YT YTL
20	IRT 2016	17.5	20	24	16.5	0.3	22	23	TA 243216Z	—	YT 243216
	IRT 2020	22	20	24	20.5	0.3	22	23	TA 2420Z	—	YT 243220
									TA 243220Z	—	
	IRT 2028	30.5	20	24	28.5	0.3	22	23	TA 2428Z	—	YT 2428
	IRT 2010-1	14.3	20	25	10.5	0.3	22	24	TA 2510Z	—	YT 2510
	IRT 2015-1	21	20	25	15.5	0.3	22	24	TA 2515Z	—	YT 2515
	IRT 2020-1	28	20	25	20.5	0.3	22	24	TA 2520Z	TLA 2520Z	YT 2520
	IRT 2025-1	34.5	20	25	25.5	0.3	22	24	TA 2525Z	—	YT 2525
	IRT 2026-1	36	20	25	26.5	0.3	22	24	—	TLA 2526Z	YTL 2526
22	IRT 2030-1	41.5	20	25	30.5	0.3	22	24	TA 2530Z	—	—
	IRT 2038-1	52.5	20	25	38.5	0.3	22	24	—	TLAW 2538Z	—
	IRT 2216	19.1	22	26	16.5	0.3	24	25	TA 2616Z	—	YT 2616
	IRT 2220	24	22	26	20.5	0.3	24	25	TA 2620Z	—	YT 2620
25	IRT 2220-1	37	22	28	20.5	0.3	24	27	TA 2820Z	TLA 2820Z	YT 2820
	IRT 2230-1	55.5	22	28	30.5	0.3	24	27	TA 2830Z	—	—
	IRT 2520	26.5	25	29	20.5	0.3	27	28	TA 2920Z	—	YT 2920
	IRT 2530	40	25	29	30.5	0.3	27	28	TA 2930Z	—	—
	IRT 2515-1	25.5	25	30	15.5	0.3	27	29	TA 3015Z	—	—
	IRT 2520-1	34	25	30	20.5	0.3	27	29	TA 3020Z	TLA 3020Z	—
	IRT 2525-1	42.5	25	30	25.5	0.3	27	29	TA 3025Z	—	—
	IRT 2526-1	44	25	30	26.5	0.3	27	29	—	TLA 3026Z	—
	IRT 2530-1	50.5	25	30	30.5	0.3	27	29	TA 3030Z	—	—
28	IRT 2538-1	64	25	30	38.5	0.3	27	29	—	TLAW 3038Z	—
	IRT 2820	29.5	28	32	20.5	0.3	30	31	TA 3220Z	—	YT 3220
30	IRT 2830	44	28	32	30.5	0.3	30	31	TA 3230Z	—	—
	IRT 3012	24.5	30	35	12.5	0.6	34	34.5	TA 3512Z	TLA 3512Z	—
	IRT 3015	30.5	30	35	15.5	0.6	34	34.5	TA 3515Z	—	—

Note⁽¹⁾ Minimum allowable value of chamfer dimension r
Remark No oil hole is provided.

Shaft dia. mm	Identification number	Mass (Ref.) g	Boundary dimensions mm				Standard mounting dimension mm		Assembled bearings		
			d	F	B	⁽¹⁾ r _{s min}	Min. d _a	Max. d _a	TA ... Z (TAM)	TLA ... Z (TLAM)	YT YTL
30	IRT 3020	40	30	35	20.5	0.6	34	34.5	TA 3520Z	TLA 3520Z	—
	IRT 3025	50	30	35	25.5	0.6	34	34.5	TA 3525Z	—	—
	IRT 3030	60	30	35	30.5	0.6	34	34.5	TA 3530Z	—	—
32	IRT 3220	42.5	32	37	20.5	0.6	36	36.5	TA 3720Z	—	YT 3720
	IRT 3230	63.5	32	37	30.5	0.6	36	36.5	TA 3730Z	—	—
	IRT 3215-1	39.5	32	38	15.5	0.6	36	37	TA 3815Z	—	—
	IRT 3220-1	52	32	38	20.5	0.6	36	37	TA 3820Z	—	—
	IRT 3225-1	64.5	32	38	25.5	0.6	36	37	TA 3825Z	—	—
	IRT 3230-1	77.5	32	38	30.5	0.6	36	37	TA 3830Z	—	—
	IRT 3245-1	115	32	38	45.5	0.6	36	37	TAW 3845Z	—	—
35	IRT 3515	35	35	40	15.5	0.6	39	39.5	TA 4015Z	—	YT 4015
	IRT 3520	46.5	35	40	20.5	0.6	39	39.5	TA 4020Z	TLA 4020Z	—
	IRT 3525	58	35	40	25.5	0.6	39	39.5	TA 4025Z	—	YT 4025
	IRT 3530	69	35	40	30.5	0.6	39	39.5	TA 4030Z	—	—
	IRT 3540	91.5	35	40	40.5	0.6	39	39.5	TA 4040Z	—	—
40	IRT 4020	52.5	40	45	20.5	0.6	44	45.5	TA 4520Z	TLA 4520Z	YT 4520
	IRT 4025	65.5	40	45	25.5	0.6	44	45.5	TA 4525Z	—	YT 4525
	IRT 4030	78.5	40	45	30.5	0.6	44	45.5	TA 4530Z	—	—
	IRT 4040	104	40	45	40.5	0.6	44	45.5	TA 4540Z	—	—
45	IRT 4512	36	45	50	12.5	0.6	49	49.5	TA 5012Z	—	—
	IRT 4515	44.5	45	50	15.5	0.6	49	49.5	TA 5015Z	—	—
	IRT 4520	59	45	50	20.5	0.6	49	49.5	TA 5020Z	TLA 5020Z	—
	IRT 4525	73	45	50	25.5	0.6	49	49.5	TA 5025Z	TLA 5025Z	—
	IRT 4530	87.5	45	50	30.5	0.6	49	49.5	TA 5030Z	—	—
	IRT 4540	116	45	50	40.5	0.6	49	49.5	TA 5040Z	—	—
	IRT 4545	131	45	50	45.5	0.6	49	49.5	TAW 5045Z	—	—

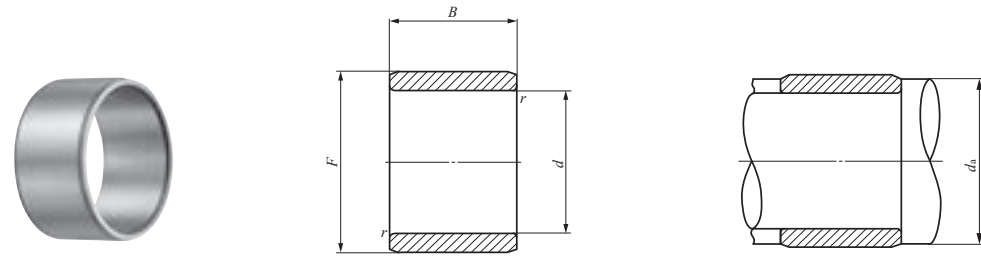
Note⁽¹⁾ Minimum allowable value of chamfer dimension r
Remark No oil hole is provided.

H

IRT
IRB
LRT
LRB

INNER RINGS

Inner Rings for Shell Type Needle Roller Bearings



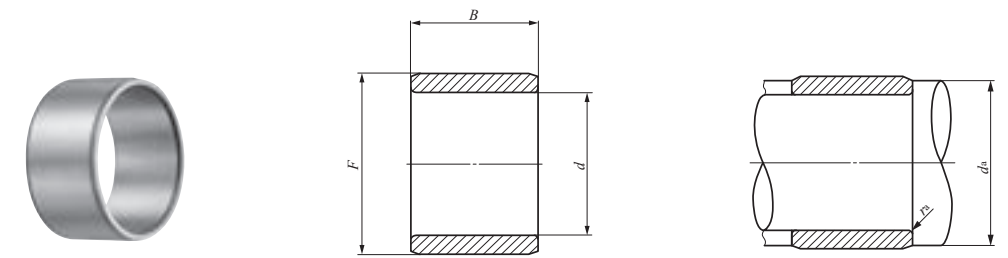
IRT

Shaft dia. 50 – 60mm

Shaft dia. mm	Identification number	Mass (Ref.) g	Boundary dimensions mm				Standard mounting dimension mm		Assembled bearings		
			d	F	B	$r_{s \text{ min}}^{(1)}$	Min. d_a	Max. d_a	TA ... Z (TAM)	TLA ... Z (TLAM)	YT YTL
50	IRT 5020-1	65	50	55	20.5	0.6	54	54.5	TA 5520Z	TLA 5520Z	—
	IRT 5025-1	81	50	55	25.5	0.6	54	54.5	TA 5525Z	TLA 5525Z	—
	IRT 5030-1	96.5	50	55	30.5	0.6	54	54.5	TA 5530Z	—	—
	IRT 5040-1	128	50	55	40.5	0.6	54	54.5	TA 5540Z	—	—
	IRT 5045-1	144	50	55	45.5	0.6	54	54.5	TAW 5545Z	—	—
	IRT 5050-1	160	50	55	50.5	0.6	54	54.5	TAW 5550Z	—	—
	IRT 5025	169	50	60	25.5	1.5	58	59	TA 6025Z	—	—
	IRT 5030	205	50	60	30.5	1.5	58	59	TA 6030Z	—	—
	IRT 5040	270	50	60	40.5	1.5	58	59	TA 6040Z	—	—
	IRT 5045	300	50	60	45.5	1.5	58	59	TAW 6045Z	—	—
IRT 5050	335	50	60	50.5	1.5	58	59	TAW 6050Z	—	—	
52	IRT 5212	86	52	62	12.5	1.5	60	60.5	TA 6212Z	—	—
55	IRT 5525	185	55	65	25.5	1.5	63	63.5	TA 6525Z	—	—
	IRT 5530	220	55	65	30.5	1.5	63	63.5	TA 6530Z	—	—
	IRT 5545	330	55	65	45.5	1.5	63	63.5	TAW 6545Z	—	—
	IRT 5550	365	55	65	50.5	1.5	63	63.5	TAW 6550Z	—	—
60	IRT 6025	200	60	70	25.5	1.5	68	68.5	TA 7025Z	—	—
	IRT 6030	240	60	70	30.5	1.5	68	68.5	TA 7030Z	—	—
	IRT 6040	320	60	70	40.5	1.5	68	68.5	TA 7040Z	—	—
	IRT 6050	395	60	70	50.5	1.5	68	68.5	TAW 7050Z	—	—

Note⁽¹⁾ Minimum allowable value of chamfer dimension r
 Remark No oil hole is provided.

Inner Rings for Shell Type Needle Roller Bearings Inch Series



IRB

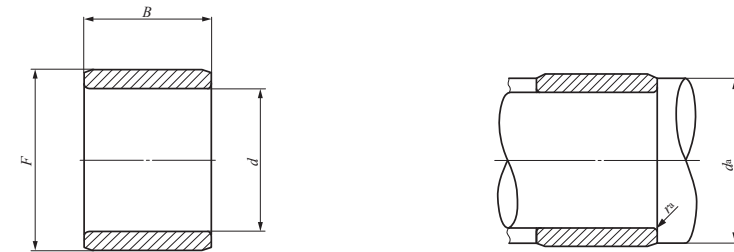
Shaft dia. 7.938 – 15.875mm

Shaft dia. mm (inch)	Identification number	Mass (Ref.) g	Boundary dimensions mm(inch)			Standard mounting dimensions mm			Assembled bearings		
			d	F	B	Min. d_a	Max. d_a	$r_{as \text{ max}}^{(1)}$	BA ... Z (BAM)	BHA ... Z (BHAM)	YB YBH
7.938 (5/16)	IRB 58	8	7.938 (5/16)	12.700 (1/2)	13.08	11.3	11.7	0.3	BA 88Z	BHA 88Z	YB 88
	IRB 68 IRB 68-1	8.9 12.6	9.525 (3/8)	14.288 (9/16)	13.08	12.8	13.2	0.3	BA 98Z	BHA 98Z	YB 98
9.525 (3/8)	IRB 612 IRB 612-1	13.2 18.8	9.525 (3/8)	14.288 (9/16)	19.43	12.8	13.2	0.3	BA 912Z	—	YB 912
	IRB 78	10.1	11.112 (7/16)	15.875 (5/8)	13.08	14.4	14.8	0.3	BA 108Z	BHA 108Z	YB 108
11.112 (7/16)	IRB 712	15	11.112 (7/16)	15.875 (5/8)	19.43	14.4	14.8	0.3	BA 1012Z	BHA 1012Z	YB 1012
	IRB 714	17.4	11.112 (7/16)	15.875 (5/8)	22.60	14.4	14.8	0.3	BA 1014Z	—	—
	IRB 716	19.9	11.112 (7/16)	15.875 (5/8)	25.78	14.4	14.8	0.3	BA 1016Z	BHA 1016Z	—
12.700 (1/2)	IRB 86	8.5	12.700 (1/2)	17.462 (11/16)	9.90	16.9	16.9	0.3	BA 116Z	—	—
	IRB 88	11.2	12.700 (1/2)	17.462 (11/16)	13.08	16.9	16.9	0.3	BA 118Z	BHA 118Z	—
	IRB 812	16.7	12.700 (1/2)	17.462 (11/16)	19.43	16.9	16.9	0.3	BA 1112Z	BHA 1112Z	YB 1112
	IRB 88-1	15.8	12.700 (1/2)	19.050 (3/4)	13.08	16.9	17.5	0.6	BA 128Z	—	YB 128
	IRB 810-1	19.6	12.700 (1/2)	19.050 (3/4)	16.25	16.9	17.5	0.6	BA 1210Z	—	YB 1210
	IRB 812-1	23.5	12.700 (1/2)	19.050 (3/4)	19.43	16.9	17.5	0.6	BA 1212Z	BHA 1212Z	YB 1212
	IRB 814-1 IRB 816-1	27.5 31	12.700 (1/2) 12.700 (1/2)	19.050 (3/4) 19.050 (3/4)	22.60 25.78	16.9 16.9	17.5 17.5	0.6 0.6	BA 1214Z BA 1216Z	— —	— —
14.288 (9/16)	IRB 98	17.3	14.288 (9/16)	20.638 (13/16)	13.08	19	19.6	0.6	BA 138Z	BHA 138Z	YB 138
	IRB 910	21.5	14.288 (9/16)	20.638 (13/16)	16.25	19	19.6	0.6	BA 1310Z	BHA 1310Z	YBH 1310
	IRB 912	26	14.288 (9/16)	20.638 (13/16)	19.43	19	19.6	0.6	BA 1312Z	BHA 1312Z	YBH 1312
	IRB 914	30	14.288 (9/16)	20.638 (13/16)	22.60	19	19.6	0.6	BA 1314Z	—	—
	IRB 916	34.5	14.288 (9/16)	20.638 (13/16)	25.78	19	19.6	0.6	BA 1316Z	—	—
	IRB 920	43	14.288 (9/16)	20.638 (13/16)	32.13	19	19.6	0.6	BA 1320Z	—	—
15.875 (5/8)	IRB 106	14.5	15.875 (5/8)	22.225 (7/8)	9.90	20.7	21.2	0.6	BA 146Z	—	—
	IRB 108	18.9	15.875 (5/8)	22.225 (7/8)	13.08	20.7	21.2	0.6	BA 148Z	—	YB 148
	IRB 1012	28	15.875 (5/8)	22.225 (7/8)	19.43	20.7	21.2	0.6	BA 1412Z	BHA 1412Z	YB 1412

Note⁽¹⁾ Maximum allowable fillet corner radius of shaft
 Remark No oil hole is provided.

INNER RINGS

Inner Rings for Shell Type Needle Roller Bearings Inch Series



IRB

Shaft dia. 15.875 – 63.500mm

Shaft dia. mm (inch)	Identification number	Mass (Ref.) g	Boundary dimensions mm(inch)			Standard mounting dimensions mm ⁽¹⁾			Assembled bearings		
			d	F	B	d _a Min.	r _{as max} Max.	BA···Z (BAM)	BHA···Z (BHAM)	YB YBH	
											Max.
15.875 (5/8)	IRB 1014	33	15.875 (5/8)	22.225 (7/8)	22.60	20.7	21.2	0.6	BA 1414Z	—	—
	IRB 1016	37.5	15.875 (5/8)	22.225 (7/8)	25.78	20.7	21.2	0.6	BA 1416Z	BHA 1416Z	YB 1416
	IRB 1022	51.5	15.875 (5/8)	22.225 (7/8)	35.30	20.7	21.2	0.6	BA 1422Z	—	—
17.462 (11/16)	IRB 1110	25.5	17.462 (11/16)	23.812 (15/16)	16.25	22.3	22.8	0.6	BA 1510Z	—	—
	IRB 1116	40.5	17.462 (11/16)	23.812 (15/16)	25.78	22.3	22.8	0.6	BA 1516Z	—	—
19.050 (3/4)	IRB 128	22	19.050 (3/4)	25.400 (1)	13.08	23.9	24.4	0.6	BA 168Z	BHA 168Z	YB 168 YBH 168
	IRB 1212	33	19.050 (3/4)	25.400 (1)	19.43	23.9	24.4	0.6	BA 1612Z	BHA 1612Z	YB 1612 YBH 1612
	IRB 1214	38.5	19.050 (3/4)	25.400 (1)	22.60	23.9	24.4	0.6	BA 1614Z	BHA 1614Z	—
	IRB 1216	43.5	19.050 (3/4)	25.400 (1)	25.78	23.9	24.4	0.6	BA 1616Z	BHA 1616Z	YB 1616 YBH 1616
	IRB 1220	54.5	19.050 (3/4)	25.400 (1)	32.13	23.9	24.4	0.6	BA 1620Z	BHA 1620Z	—
20.638 (13/16)	IRB 1316	34	20.638 (13/16)	25.400 (1)	25.78	24.9	24.9	0.6	BA 1616Z	BHA 1616Z	YB 1616 YBH 1616
22.225 (7/8)	IRB 148	25	22.225 (7/8)	28.575 (1 1/8)	13.08	27	27.5	0.6	BA 188Z	—	YB 188
	IRB 1412	37.5	22.225 (7/8)	28.575 (1 1/8)	19.43	27	27.5	0.6	BA 1812Z	BHA 1812Z	YB 1812
	IRB 1416	50	22.225 (7/8)	28.575 (1 1/8)	25.78	27	27.5	0.6	BA 1816Z	BHA 1816Z	YB 1816
	IRB 1420	62.5	22.225 (7/8)	28.575 (1 1/8)	32.13	27	27.5	0.6	BA 1820Z	BHA 1820Z	—
25.400 (1)	IRB 168	28.5	25.400 (1)	31.750 (1 1/4)	13.08	30	30.7	0.6	BA 208Z	BHA 208Z	—
	IRB 1610	35.5	25.400 (1)	31.750 (1 1/4)	16.25	30	30.7	0.6	BA 2010Z	—	YB 2010
	IRB 1612	42.5	25.400 (1)	31.750 (1 1/4)	19.43	30	30.7	0.6	BA 2012Z	BHA 2012Z	YB 2012
	IRB 1616	56	25.400 (1)	31.750 (1 1/4)	25.78	30	30.7	0.6	BA 2016Z	BHA 2016Z	YB 2016
	IRB 1620	70	25.400 (1)	31.750 (1 1/4)	32.13	30	30.7	0.6	BA 2020Z	BHA 2020Z	—
	IRB 168-1	36.5	25.400 (1)	33.338 (1 5/16)	13.08	30	32.1	0.6	BA 218Z	—	—
	IRB 1610-1	45.5	25.400 (1)	33.338 (1 5/16)	16.25	30	32.1	0.6	BA 2110Z	—	—
	IRB 1612-1	54.5	25.400 (1)	33.338 (1 5/16)	19.43	30	32.1	0.6	BA 2112Z	—	—

Note(1) Maximum allowable fillet corner radius of shaft
Remark No oil hole is provided.

Shaft dia. mm (inch)	Identification number	Mass (Ref.) g	Boundary dimensions mm(inch)			Standard mounting dimensions mm ⁽¹⁾			Assembled bearings		
			d	F	B	d _a Min.	r _{as max} Max.	BA···Z (BAM)	BHA···Z (BHAM)	YB YBH	
											Max.
28.575 (1 1/8)	IRB 188	31.5	28.575 (1 1/8)	34.925 (1 3/8)	13.08	33.2	33.9	0.6	BA 228Z	BHA 228Z	YB 228
	IRB 1812	47	28.575 (1 1/8)	34.925 (1 3/8)	19.43	33.2	33.9	0.6	BA 2212Z	BHA 2212Z	YB 2212
	IRB 1816	62.5	28.575 (1 1/8)	34.925 (1 3/8)	25.78	33.2	33.9	0.6	BA 2216Z	BHA 2216Z	—
	IRB 1820	78	28.575 (1 1/8)	34.925 (1 3/8)	32.13	33.2	33.9	0.6	BA 2220Z	BHA 2220Z	YB 2220
31.750 (1 1/4)	IRB 2010	43	31.750 (1 1/4)	38.100 (1 1/2)	16.25	37	37.1	0.6	BA 2410Z	—	—
	IRB 2014	60	31.750 (1 1/4)	38.100 (1 1/2)	22.60	37	37.1	0.6	BA 2414Z	—	YB 2414
	IRB 2016	68.5	31.750 (1 1/4)	38.100 (1 1/2)	25.78	37	37.1	0.6	BA 2416Z	—	YB 2416
	IRB 2020	85.5	31.750 (1 1/4)	38.100 (1 1/2)	32.13	37	37.1	0.6	BA 2420Z	—	YB 2420
34.925 (1 3/8)	IRB 2210	47	34.925 (1 3/8)	41.275 (1 5/8)	16.25	40.2	40.2	0.6	BA 2610Z	—	YB 2610
	IRB 2220	93.5	34.925 (1 3/8)	41.275 (1 5/8)	32.13	40.2	40.2	0.6	BA 2620Z	—	—
36.512 (1 7/16)	IRB 2316	99	36.512 (1 7/16)	44.450 (1 3/4)	25.78	42.5	43.2	0.6	BA 2816Z	—	—
38.100 (1 1/2)	IRB 2412	62	38.100 (1 1/2)	44.450 (1 3/4)	19.43	43.3	43.4	0.6	BA 2812Z	—	—
	IRB 2416	81	38.100 (1 1/2)	44.450 (1 3/4)	25.78	43.3	43.4	0.6	BA 2816Z	—	YB 2816
	IRB 2424	121	38.100 (1 1/2)	44.450 (1 3/4)	38.48	43.3	43.4	0.6	BA 2824Z	BHA 2824Z	—
	IRB 248-1 IRB 2410-1	64 79.5	38.100 (1 1/2) 38.100 (1 1/2)	47.625 (1 7/8) 47.625 (1 7/8)	13.08 16.25	44.5 44.5	45.5 45.5	1 1	BA 308Z BA 3010Z	— —	— —
41.275 (1 5/8)	IRB 2616	136	41.275 (1 5/8)	50.800 (2)	25.78	47.5	48.5	1	BA 3216Z	—	—
	IRB 2628	235	41.275 (1 5/8)	50.800 (2)	44.83	47.5	48.5	1	BAW 3228Z	—	—
42.862 (1 11/16)	IRB 2720	146	42.862 (1 11/16)	50.800 (2)	32.13	48.5	49.5	0.6	BA 3220Z	—	—
47.625 (1 7/8)	IRB 3016	100	47.625 (1 7/8)	53.975 (2 1/8)	25.78	52.9	52.9	0.6	BA 3416Z	—	—
	IRB 3024	149	47.625 (1 7/8)	53.975 (2 1/8)	38.48	52.9	52.9	0.6	BA 3424Z	—	—
57.150 (2 1/4)	IRB 3616	183	57.150 (2 1/4)	66.675 (2 5/8)	25.78	63.5	64.5	1	BA 4216Z	—	—
63.500 (2 1/2)	IRB 4016	131	63.500 (2 1/2)	69.850 (2 3/4)	25.78	68.7	68.8	0.6	BA 4416Z	—	—
	IRB 4020	164	63.500 (2 1/2)	69.850 (2 3/4)	32.13	68.7	68.8	0.6	BA 4420Z	—	—

Note(1) Maximum allowable fillet corner radius of shaft
Remark No oil hole is provided.

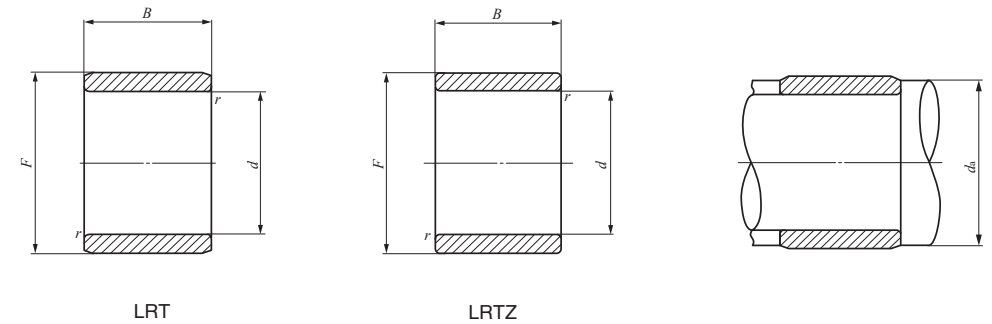
Inner Rings for General Usage



Shaft dia. 5 – 20mm

Shaft dia. mm	Identification number	Mass (Ref.) g	Boundary dimensions mm				Standard mounting dimension mm		Assembled bearings	
			<i>d</i>	<i>F</i>	<i>B</i>	<i>r_{s min}</i> ⁽¹⁾	Min.	Max.	<i>d_a</i>	
5	LRT 5710	1.4	5	7	10	0.15	6.2	6.7	RNA 495	
	LRT 5812	2.8	5	8	12	0.2	6.6	7.7	TAF 81512	
	LRT 5816	3.8	5	8	16	0.2	6.6	7.7	TAF 81516	
6	LRT 6810	1.7	6	8	10	0.15	7.2	7.7	RNA 496	
	LRT 6912	3.2	6	9	12	0.2	7.6	8.7	TAF 91612	
	LRT 6916	4.3	6	9	16	0.2	7.6	8.7	TAF 91616	
	LRT 61010	3.9	6	10	10	0.3	8	9.7	RNAF 101710	
7	LRT 7910	1.9	7	9	10	0.15	8.2	8.7	RNA 497	
	LRT 71012	3.6	7	10	12	0.2	8.6	9.7	TAF 101712	
	LRT 71012-1	3.6	7	10	12	0.3	9	9.7	RNAF 102012	
	LRT 71016	4.9	7	10	16	0.2	8.6	9.7	TAF 101716 NAX 1023	
8	LRT 81011	2.4	8	10	11	0.2	9.6	9.9	RNA 498	
9	LRT 91211	3.1	9	12	11	0.3	11	11.5	RNA 499	
	LRT 91212	4.5	9	12	12	0.3	11	11.5	TAF 121912 RNAF 122212	
	LRT 91216	6	9	12	16	0.3	11	11.5	TAF 121916 NAX 1223	
10	LRT 101412	7	10	14	12	0.3	12	13	RNAF 142612	
	LRT 101413	7.5	10	14	13	0.3	12	13	RNA 4900 RNAF 142213	
	—	LRTZ 101414	8.2	10	14	14	0.3	12	13	RNA 4900 UU
	LRT 101416	9	10	14	16	0.3	12	13	TAF 142216	
	LRT 101420	11.5	10	14	20	0.3	12	13	TAF 142220 RNAFW142220	
12	LRT 121516	8	12	15	16.5	0.3	14	14.5	NAX 1523 NBX 1523	
	LRT 121612	8.5	12	16	12	0.3	14	15	RNAF 162812	
	LRT 121613	8.5	12	16	13	0.3	14	15	RNA 4901 RNAF 162413	
	—	LRTZ 121614	9.6	12	16	14	0.3	14	15	RNA 4901 UU
	LRT 121616	10.5	12	16	16	0.3	14	15	TAF 162416	
	LRT 121620	13.5	12	16	20	0.3	14	15	TAF 162420 RNAFW162420	

Note⁽¹⁾ Minimum allowable value of chamfer dimension *r*
 Remark No oil hole is provided.



Shaft dia. mm	Identification number	Mass (Ref.) g	Boundary dimensions mm				Standard mounting dimension mm		Assembled bearings	
			<i>d</i>	<i>F</i>	<i>B</i>	<i>r_{s min}</i> ⁽¹⁾	Min.	Max.	<i>d_a</i>	
12	LRT 121622	14.5	12	16	22	0.3	14	15	RNA 6901	
	—	LRTZ 121623	15.5	12	16	23	0.3	14	15	RNA 6901 UU
14	LRT 141717	9.5	14	17	17	0.3	16	16.5	NAX 1725 NBX 1725	
15	LRT 151916	12.5	15	19	16	0.3	17	18	TAF 192716	
	LRT 151920	16	15	19	20	0.3	17	18	TAF 192720	
	LRT 152012	12	15	20	12	0.3	17	19	RNAF 203212	
	LRT 152013	13.5	15	20	13	0.3	17	19	RNA 4902 RNAF 202813	
	—	LRTZ 152014	14.5	15	20	14	0.3	17	19	RNA 4902 UU
	LRT 152020	21.5	15	20	20.5	0.3	17	19	TR 203320	
	—	LRTZ 152020	21.5	15	20	20.5	0.3	17	19	GTR 203320
	LRT 152023	24	15	20	23	0.3	17	19	RNA 6902	
	—	LRTZ 152024	25	15	20	24	0.3	17	19	RNA 6902 UU
	LRT 152026	28	15	20	26	0.3	17	19	RNAFW 202826	
17	LRT 172020	13.5	17	20	20.5	0.3	19	19.5	NAX 2030 NBX 2030	
	LRT 172116	14.5	17	21	16	0.3	19	20	TAF 212916	
	LRT 172120	18	17	21	20	0.3	19	20	TAF 212920	
	LRT 172213	15.5	17	22	13	0.3	19	21	RNA 4903 RNAF 223013	
	—	LRTZ 172214	16.5	17	22	14	0.3	19	21	RNA 4903 UU
	LRT 172216	19	17	22	16	0.3	19	21	RNAF 223516	
	LRT 172223	26.5	17	22	23	0.3	19	21	RNA 6903	
	—	LRTZ 172224	28	17	22	24	0.3	19	21	RNA 6903 UU
	LRT 172225	30	17	22	25.5	0.3	19	21	TR 223425	
	—	LRTZ 172225	30	17	22	25.5	0.3	19	21	GTR 223425
20	LRT 202416	16.5	20	24	16	0.3	22	23	TAF 243216	
	LRT 202420	20.5	20	24	20	0.3	22	23	TAF 243220	

Note⁽¹⁾ Minimum allowable value of chamfer dimension *r*
 Remark No oil hole is provided.

H
 IRT
 IRB
 LRT
 LRB

INNER RINGS

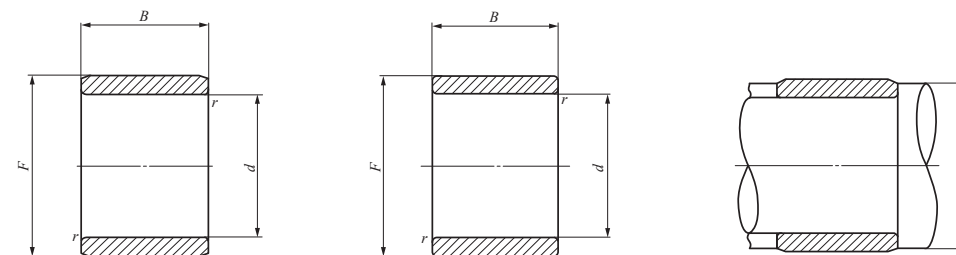
Inner Rings for General Usage



Shaft dia. 20 – 32mm

Shaft dia. mm	Identification number		Mass (Ref.) g	Boundary dimensions mm				Standard mounting dimension mm		Assembled bearings
				d	F	B	⁽¹⁾ r _{s min}	d _a Min. Max.		
20	LRT 202516	—	22	20	25	16	0.3	22	24	RNAF 253716
	LRT 202517	—	23	20	25	17	0.3	22	24	RNA 4904 RNAF 253517
	—	LRTZ 202518	24	20	25	18	0.3	22	24	RNA 4904 UU
	LRT 202520	—	28	20	25	20.5	0.3	22	24	TR 253820 NAX 2530 NBX 2530
	—	LRTZ 202520	28	20	25	20.5	0.3	22	24	GTR 253820
	LRT 202525	—	35	20	25	25.5	0.3	22	24	TR 253825
	—	LRTZ 202525	35	20	25	25.5	0.3	22	24	GTR 253825
	LRT 202526	—	36	20	25	26	0.3	22	24	RNAFW 253526
	LRT 202530	—	40.5	20	25	30	0.3	22	24	RNA 6904
—	LRTZ 202531	41.5	20	25	31	0.3	22	24	RNA 6904 UU	
LRT 202532	—	44	20	25	32	0.3	22	24	RNAFW 253732	
22	LRT 222616	—	17.5	22	26	16	0.3	24	25	TAF 263416
	LRT 222620	—	24	22	26	20	0.3	24	25	TAF 263420
	LRT 222817	—	30.5	22	28	17	0.3	24	27	RNA 49/22
	—	LRTZ 222818	32	22	28	18	0.3	24	27	RNA 49/22 UU
	LRT 222830	—	55	22	28	30	0.3	24	27	RNA 69/22
—	LRTZ 222831	55	22	28	31	0.3	24	27	RNA 69/22 UU	
25	LRT 252920	—	25	25	29	20	0.3	27	28	TAF 293820
	LRT 252930	—	38	25	29	30	0.3	27	28	TAF 293830
	LRT 253016	—	28	25	30	16	0.3	27	29	RNAF 304216
	LRT 253017	—	28.5	25	30	17	0.3	27	29	RNA 4905 RNAF 304017
	—	LRTZ 253018	29.5	25	30	18	0.3	27	29	RNA 4905 UU
	LRT 253020	—	34	25	30	20.5	0.3	27	29	NAX 3030 NBX 3030
	LRT 253025	—	42	25	30	25.5	0.3	27	29	TR 304425
	—	LRTZ 253025	42	25	30	25.5	0.3	27	29	GTR 304425
	LRT 253026	—	44.5	25	30	26	0.3	27	29	RNAFW 304026
LRT 253030	—	49	25	30	30	0.3	27	29	RNA 6905	

Note⁽¹⁾ Minimum allowable value of chamfer dimension r
 Remark No oil hole is provided.



LRT

LRTZ

Shaft dia. mm	Identification number		Mass (Ref.) g	Boundary dimensions mm				Standard mounting dimension mm		Assembled bearings
				d	F	B	⁽¹⁾ r _{s min}	d _a Min. Max.		
25	—	LRTZ 253031	51	25	30	31	0.3	27	29	RNA 6905 UU
	LRT 253032	—	54	25	30	32	0.3	27	29	RNAFW 304232
28	LRT 283217	—	24.5	28	32	17	0.3	30	31	RNA 49/28
	—	LRTZ 283218	25.5	28	32	18	0.3	30	31	RNA 49/28 UU
	LRT 283220	—	28.5	28	32	20	0.3	30	31	TAF 324220
	LRT 283230	—	43	28	32	30	0.3	30	31	RNA 69/28 TAF 324230
	—	LRTZ 283230	43	28	32	30.5	0.3	30	31	GTR 324530
—	LRTZ 283231	44	28	32	31	0.3	30	31	RNA 69/28 UU	
30	LRT 303516	—	31.5	30	35	16	0.3	32	34	RNAF 354716
	LRT 303517	—	33.5	30	35	17	0.3	32	34	RNA 4906 RNAF 354517
	—	LRTZ 303518	35	30	35	18	0.3	32	34	RNA 4906 UU
	LRT 303520	—	38.5	30	35	20	0.3	32	34	TAF 354520 NAX 3530 NBX 3530
	LRT 303526	—	52	30	35	26	0.3	32	34	RNAFW 354526
	LRT 303530	—	59	30	35	30	0.3	32	34	RNA 6906 TAF 354530
	LRT 303530-1	—	59	30	35	30.5	0.3	32	34	TR 354830
	—	LRTZ 303530	59	30	35	30.5	0.3	32	34	GTR 354830
	—	LRTZ 303531	61	30	35	31	0.3	32	34	RNA 6906 UU
LRT 303532	—	64	30	35	32	0.3	32	34	RNAFW 354732	
32	LRT 323720	—	43.5	32	37	20	0.3	34	36	TAF 374720
	LRT 323730	—	63	32	37	30	0.3	34	36	TAF 374730
	LRT 323830	—	77	32	38	30.5	0.6	36	37	TR 385230
	—	LRTZ 323830	77	32	38	30.5	0.6	36	37	GTR 385230
	LRT 324020	—	69	32	40	20	0.6	36	39	RNA 49/32
	—	LRTZ 324021	72.5	32	40	21	0.6	36	39	RNA 49/32 UU
	LRT 324036	—	123	32	40	36	0.6	36	39	RNA 69/32
	—	LRTZ 324037	130	32	40	37	0.6	36	39	RNA 69/32 UU

Note⁽¹⁾ Minimum allowable value of chamfer dimension r
 Remark No oil hole is provided.

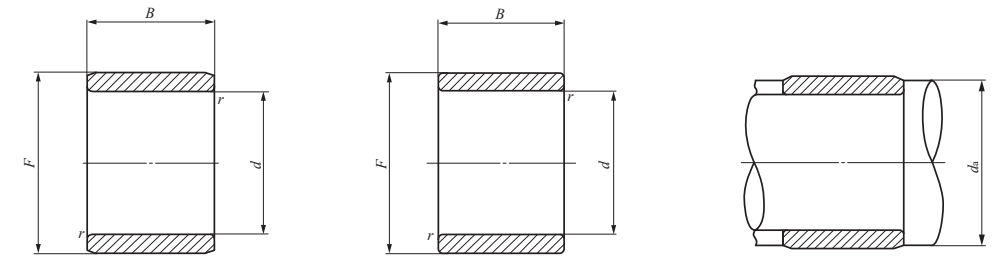
Inner Rings for General Usage



Shaft dia. 35 – 50mm

Shaft dia. mm	Identification number		Mass (Ref.) g	Boundary dimensions mm				Standard mounting dimension mm		Assembled bearings	
				d	F	B	r _{s min} ⁽¹⁾	Min.	Max.		
35	LRT 354017	—	39	35	40	17	0.3	37	39	RNAF 405017	
	LRT 354020	—	46	35	40	20	0.3	37	39	TAF 405020 RNAF 405520 NAX 4032 NBX 4032	
	—	LRTZ 354020	46	35	40	20.5	0.6	39	39.5	GTR 405520	
	LRT 354030	—	67	35	40	30	0.3	37	39	TAF 405030	
	LRT 354034	—	78	35	40	34	0.3	37	39	RNAFW 405034	
	LRT 354040	—	95	35	40	40	0.3	37	39	RNAFW 405540	
	LRT 354220	—	65	35	42	20	0.6	39	41	RNA 4907	
	—	LRTZ 354221	67	35	42	21	0.6	39	41	RNA 4907 UU	
	LRT 354230	—	97	35	42	30.5	0.6	39	41	TR 425630	
	—	LRTZ 354230	100	35	42	30.5	0.6	39	41	GTR 425630	
	LRT 354236	—	120	35	42	36	0.6	39	41	RNA 6907	
—	LRTZ 354237	120	35	42	37	0.6	39	41	RNA 6907 UU		
38	LRT 384320	—	47.5	38	43	20	0.3	40	42	TAF 435320	
	LRT 384330	—	72	38	43	30	0.3	40	42	TAF 435330	
40	LRT 404517	—	44.5	40	45	17	0.3	42	44	RNAF 455517	
	LRT 404520	—	51	40	45	20	0.3	42	44	TAF 455520 RNAF 456220 NAX 4532 NBX 4532	
	LRT 404530	—	77	40	45	30	0.3	42	44	TAF 455530	
	LRT 404530-1	—	77	40	45	30.5	0.6	44	44.5	TR 455930	
	—	LRTZ 404530	77	40	45	30.5	0.6	44	44.5	GTR 455930	
	LRT 404534	—	88	40	45	34	0.3	42	44	RNAFW 455534	
	LRT 404540	—	105	40	45	40	0.3	42	44	RNAFW 456240	
	LRT 404822	—	93	40	48	22	0.6	44	47	RNA 4908	
	—	LRTZ 404823	95	40	48	23	0.6	44	47	RNA 4908 UU	
	LRT 404840	—	165	40	48	40	0.6	44	47	RNA 6908	
—	LRTZ 404841	170	40	48	41	0.6	44	47	RNA 6908 UU		

Note⁽¹⁾ Minimum allowable value of chamfer dimension *r*
Remark No oil hole is provided.



LRT

LRTZ

Shaft dia. mm	Identification number		Mass (Ref.) g	Boundary dimensions mm				Standard mounting dimension mm		Assembled bearings	
				d	F	B	r _{s min} ⁽¹⁾	Min.	Max.		
42	LRT 424720	—	54	42	47	20	0.3	44	46	TAF 475720	
	LRT 424730	—	81	42	47	30	0.3	44	46	TAF 475730	
	LRT 424830	—	100	42	48	30.5	0.6	46	47	TR 486230	
	—	LRTZ 424830	100	42	48	30.5	0.6	46	47	GTR 486230	
45	LRT 455020	—	58	45	50	20	0.3	47	49	RNAF 506220	
	LRT 455025	—	71	45	50	25	0.3	47	49	TAF 506225 NAX 5035 NBX 5035	
	LRT 455030	—	90	45	50	30.5	0.6	49	49.5	TR 506430	
	—	LRTZ 455030	90	45	50	30.5	0.6	49	49.5	GTR 506430	
	LRT 455035	—	95	45	50	35	0.3	47	49	TAF 506235	
	LRT 455040	—	115	45	50	40	0.3	47	49	RNAFW 506240	
	LRT 455222	—	88	45	52	22	0.6	49	51	RNA 4909	
	—	LRTZ 455223	93	45	52	23	0.6	49	51	RNA 4909 UU	
	LRT 455240	—	165	45	52	40	0.6	49	51	RNA 6909	
	—	LRTZ 455241	170	45	52	41	0.6	49	51	RNA 6909 UU	
	LRT 455520	—	120	45	55	20	1	50	54	RNAF 557220	
LRT 455540	—	245	45	55	40	1	50	54	RNAFW 557240		
50	LRT 505520	—	63	50	55	20	0.3	52	54	RNAF 556820	
	LRT 505525	—	77	50	55	25	0.3	52	54	TAF 556825	
	LRT 505535	—	110	50	55	35	0.3	52	54	TAF 556835	
	LRT 505540	—	130	50	55	40	0.3	52	54	RNAFW 556840	
	LRT 505822	—	116	50	58	22	0.6	54	57	RNA 4910	
	—	LRTZ 505823	118	50	58	23	0.6	54	57	RNA 4910 UU	
	LRT 505840	—	210	50	58	40	0.6	54	57	RNA 6910	
	—	LRTZ 505841	215	50	58	41	0.6	54	57	RNA 6910 UU	
	LRT 505845	—	235	50	58	45.5	1	55	57	TR 587745	
	—	LRTZ 505845	235	50	58	45.5	1	55	57	GTR 587745	
LRT 506020	—	135	50	60	20	1	55	59	RNAF 607820		

Note⁽¹⁾ Minimum allowable value of chamfer dimension *r*
Remark No oil hole is provided.

INNER RINGS

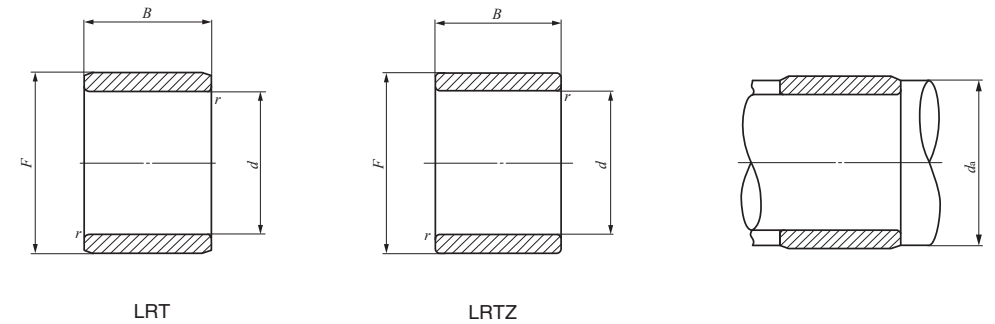
Inner Rings for General Usage



Shaft dia. 50 – 80mm

Shaft dia. mm	Identification number	Mass (Ref.) g	Boundary dimensions mm					Standard mounting dimension mm		Assembled bearings
			<i>d</i>	<i>F</i>	<i>B</i>	<i>r_{s min}</i> ⁽¹⁾	<i>d_a</i> Min. Max.			
50	LRT 506025	165	50	60	25.5	1	55	59	NAX 6040 NBX 6040 RNAFW 607840	
	LRT 506040	265	50	60	40	1	55	59		
55	LRT 556025	88	55	60	25	0.3	57	59	TAF 607225	
	LRT 556035	120	55	60	35	0.3	57	59	TAF 607235	
	LRT 556238	190	55	62	38.5	1	60	60.5	TR 628138	
	—	LRTZ 556238	190	55	62	38.5	1	60	60.5	GTR 628138
	LRT 556325	145	55	63	25	1	60	61	RNA 4911	
	—	LRTZ 556326	150	55	63	26	1	60	61	RNA 4911 UU
	LRT 556345	255	55	63	45	1	60	61	RNA 6911	
	—	LRTZ 556346	260	55	63	46	1	60	61	RNA 6911 UU
60	LRT 556530	220	55	65	30	1.5	63	63.5	RNAF 658530	
	LRT 556560	435	55	65	60	1.5	63	63.5	RNAFW 658560	
60	LRT 606825	150	60	68	25	0.6	64	66	TAF 688225	
	LRT 606825-1	150	60	68	25	1	65	66	RNA 4912	
	—	LRTZ 606826	160	60	68	26	1	65	66	RNA 4912 UU
	LRT 606835	210	60	68	35	0.6	64	66	TAF 688235	
	LRT 606845	275	60	68	45	1	65	66	RNA 6912	
	—	LRTZ 606846	280	60	68	46	1	65	66	RNA 6912 UU
	LRT 607025	195	60	70	25.5	1	65	68	NAX 7040	
	LRT 607030	240	60	70	30	1.5	68	68.5	RNAF 709030	
	LRT 607045	355	60	70	45.5	1	65	68	TR 708945	
	—	LRTZ 607045	360	60	70	45.5	1	65	68	GTR 708945
LRT 607060	480	60	70	60	1.5	68	68.5	RNAFW 709060		
65	LRT 657225	145	65	72	25	1	70	70.5	RNA 4913	
	—	LRTZ 657226	150	65	72	26	1	70	70.5	RNA 4913 UU
	LRT 657245	255	65	72	45	1	70	70.5	RNA 6913	
	—	LRTZ 657246	265	65	72	46	1	70	70.5	RNA 6913 UU
	LRT 657335	235	65	73	35	1	70	71	TAF 739035	

Note⁽¹⁾ Minimum allowable value of chamfer dimension *r*
Remark No oil hole is provided.



Shaft dia. mm	Identification number	Mass (Ref.) g	Boundary dimensions mm					Standard mounting dimension mm		Assembled bearings
			<i>d</i>	<i>F</i>	<i>B</i>	<i>r_{s min}</i> ⁽¹⁾	<i>d_a</i> Min. Max.			
65	LRT 657530	260	65	75	30	1.5	73	73.5	RNAF 759530 RNAFW 759560	
	LRT 657560	520	65	75	60	1.5	73	73.5		
70	LRT 708025	225	70	80	25	1	75	78	TAF 809525	
	LRT 708030	275	70	80	30	1	75	78	RNA 4914	
	LRT 708030-1	275	70	80	30	1.5	78	78.5	RNAF 8010030	
	—	LRTZ 708031	275	70	80	31	1	75	78	RNA 4914 UU
	LRT 708035	310	70	80	35	1	75	78	TAF 809535	
	LRT 708054	490	70	80	54	1	75	78	RNA 6914	
	—	LRTZ 708055	500	70	80	55	1	75	78	RNA 6914 UU
75	LRT 708060	560	70	80	60	1.5	78	78.5	RNAFW 8010060	
	LRT 758345	350	75	83	45.5	1	80	81	TR 8310845	
75	—	LRTZ 758345	350	75	83	45.5	1	80	81	GTR 8310845
	LRT 758525	240	75	85	25	1	80	83	TAF 8510525	
	LRT 758530	290	75	85	30	1	80	83	RNA 4915	
	LRT 758530-1	290	75	85	30	1.5	83	83.5	RNAF 8510530	
	—	LRTZ 758531	300	75	85	31	1	80	83	RNA 4915 UU
	LRT 758535	335	75	85	35	1	80	83	TAF 8510535	
	LRT 758554	520	75	85	54	1	80	83	RNA 6915	
—	LRTZ 758555	530	75	85	55	1	80	83	RNA 6915 UU	
80	LRT 809025	255	80	90	25	1	85	88	TAF 9011025	
	LRT 809030	310	80	90	30	1	85	88	RNA 4916	
	LRT 809030-1	310	80	90	30	1.5	88	88.5	RNAF 9011030	
	—	LRTZ 809031	315	80	90	31	1	85	88	RNA 4916 UU
	LRT 809035	355	80	90	35	1	85	88	TAF 9011035	
	LRT 809054	550	80	90	54	1	85	88	RNA 6916	
—	LRTZ 809055	560	80	90	55	1	85	88	RNA 6916 UU	

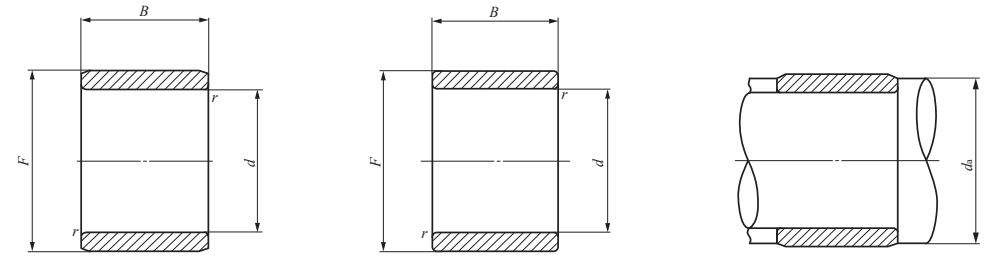
Note⁽¹⁾ Minimum allowable value of chamfer dimension *r*
Remark No oil hole is provided.

H

IRT
IRB
LRT
LRB

INNER RINGS

Inner Rings for General Usage



LRT

LRTZ

Shaft dia. 85 – 140mm

Shaft dia. mm	Identification number		Mass (Ref.) g	Boundary dimensions mm				Standard mounting dimension mm		Assembled bearings
				<i>d</i>	<i>F</i>	<i>B</i>	<i>r_{s min}</i> ⁽¹⁾	Min.	Max.	
85	LRT 859350	—	440	85	93	50.5	1	90	91	TR 9311850
	—	LRTZ 859350	440	85	93	50.5	1	90	91	GTR 9311850
	LRT 859526	—	280	85	95	26	1	90	93	TAF 9511526
	LRT 859530	—	330	85	95	30	1.5	93	93.5	RNAF 9511530
	LRT 859536	—	390	85	95	36	1	90	93	TAF 9511536
	LRT 859545	—	490	85	95	45.5	1.5	93	93.5	TR 9512045
	—	LRTZ 859545	490	85	95	45.5	1.5	93	93.5	GTR 9512045
	LRT 8510035	—	575	85	100	35	1.1	91.5	98	RNA 4917
	—	LRTZ 8510036	605	85	100	36	1.1	91.5	98	RNA 4917 UU
	LRT 8510063	—	1 040	85	100	63	1.1	91.5	98	RNA 6917
—	LRTZ 8510064	1 060	85	100	64	1.1	91.5	98	RNA 6917 UU	
90	LRT 9010026	—	295	90	100	26	1	95	98	TAF 10012026
	LRT 9010030	—	355	90	100	30	1.5	98	98.5	RNAF 10012030
	LRT 9010036	—	415	90	100	36	1	95	98	TAF 10012036
	LRT 9010050	—	580	90	100	50.5	1.5	98	98.5	TR 10012550
	—	LRTZ 9010050	580	90	100	50.5	1.5	98	98.5	GTR 10012550
	LRT 9010535	—	610	90	105	35	1.1	96.5	103	RNA 4918
	—	LRTZ 9010536	630	90	105	36	1.1	96.5	103	RNA 4918 UU
	LRT 9010563	—	1 100	90	105	63	1.1	96.5	103	RNA 6918
—	LRTZ 9010564	1 120	90	105	64	1.1	96.5	103	RNA 6918 UU	
95	LRT 9510526	—	315	95	105	26	1	100	103	TAF 10512526
	LRT 9510536	—	430	95	105	36	1	100	103	TAF 10512536
	LRT 9511035	—	650	95	110	35	1.1	101.5	108	RNA 4919
	—	LRTZ 9511036	660	95	110	36	1.1	101.5	108	RNA 4919 UU
	LRT 9511063	—	1 160	95	110	63	1.1	101.5	108	RNA 6919
	—	LRTZ 9511064	1 180	95	110	64	1.1	101.5	108	RNA 6919 UU

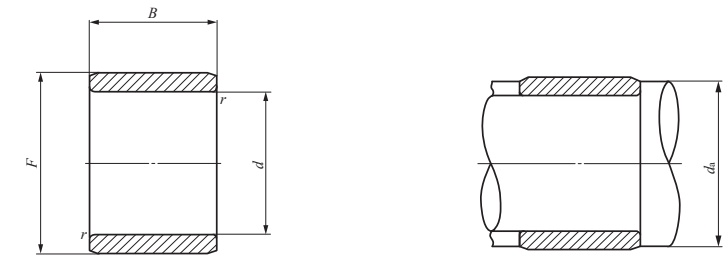
Note⁽¹⁾ Minimum allowable value of chamfer dimension *r*
 Remark No oil hole is provided.

Shaft dia. mm	Identification number		Mass (Ref.) g	Boundary dimensions mm				Standard mounting dimension mm		Assembled bearings
				<i>d</i>	<i>F</i>	<i>B</i>	<i>r_{s min}</i> ⁽¹⁾	Min.	Max.	
100	LRT 10011030	—	380	100	110	30	1	105	108	TAF 11013030
	LRT 10011040	—	500	100	110	40	1	105	108	TAF 11013040
	LRT 10011050	—	640	100	110	50.5	1.5	108	108.5	TR 11013550
	—	LRTZ 10011050	640	100	110	50.5	1.5	108	108.5	GTR 11013550
	LRT 10011540	—	770	100	115	40	1.1	106.5	113	RNA 4920
	—	LRTZ 10011541	780	100	115	41	1.1	106.5	113	RNA 4920 UU
105	LRT 10511550	—	670	105	115	50.5	1.5	113	113.5	TR 11515350
	—	LRTZ 10511550	670	105	115	50.5	1.5	113	113.5	GTR 11515350
110	LRT 11012030	—	410	110	120	30	1	115	118	RNA 4822
	LRT 11012540	—	840	110	125	40	1.1	116.5	123	RNA 4922
	—	LRTZ 11012541	870	110	125	41	1.1	116.5	123	RNA 4922 UU
120	LRT 12013030	—	450	120	130	30	1	125	128	RNA 4824
	LRT 12013545	—	1 030	120	135	45	1.1	126.5	133	RNA 4924
	—	LRTZ 12013546	1 050	120	135	46	1.1	126.5	133	RNA 4924 UU
125	LRT 12514060	—	1 460	125	140	60.5	1.5	133	138	TR 14017860
	—	LRTZ 12514060	1 460	125	140	60.5	1.5	133	138	GTR 14017860
130	LRT 13014535	—	860	130	145	35	1.1	136.5	143	RNA 4826
	LRT 13015050	—	1 670	130	150	50	1.5	138	148	RNA 4926
	—	LRTZ 13015051	1 720	130	150	51	1.5	138	148	RNA 4926 UU
135	LRT 13515060	—	1 560	135	150	60.5	1.5	143	148	TR 15018860
	—	LRTZ 13515060	1 560	135	150	60.5	1.5	143	148	GTR 15018860
140	LRT 14015535	—	930	140	155	35	1.1	146.5	153	RNA 4828
	LRT 14016050	—	1 790	140	160	50	1.5	148	158	RNA 4928
	—	LRTZ 14016051	1 830	140	160	51	1.5	148	158	RNA 4928 UU

Note⁽¹⁾ Minimum allowable value of chamfer dimension *r*
 Remark No oil hole is provided.

INNER RINGS

Inner Rings for General Usage



LRT

Shaft dia. 150 – 440mm

Shaft dia. mm	Identification number	Mass (Ref.) g	Boundary dimensions mm				Standard mounting dimension mm		Assembled bearings
			d	F	B	⁽¹⁾ r _{s min}	Min.	Max.	
150	LRT 15016540	1 130	150	165	40	1.1	156.5	163	RNA 4830
	LRT 15017060	2 290	150	170	60	2	159	168	RNA 4930
160	LRT 16017540	1 200	160	175	40	1.1	166.5	173	RNA 4832
	LRT 16018060	2 440	160	180	60	2	169	178	RNA 4932
170	LRT 17018545	1 420	170	185	45	1.1	176.5	183	RNA 4834
	LRT 17019060	2 580	170	190	60	2	179	188	RNA 4934
180	LRT 18019545	1 500	180	195	45	1.1	186.5	193	RNA 4836
	LRT 18020569	3 950	180	205	69	2	189	203	RNA 4936
190	LRT 19021050	2 380	190	210	50	1.5	198	208	RNA 4838
	LRT 19021569	4 200	190	215	69	2	199	213	RNA 4938
200	LRT 20022050	2 520	200	220	50	1.5	208	218	RNA 4840
	LRT 20022580	5 000	200	225	80	2.1	211	223	RNA 4940
220	LRT 22024050	2 750	220	240	50	1.5	228	238	RNA 4844
	LRT 22024580	5 500	220	245	80	2.1	231	243	RNA 4944
240	LRT 24026560	4 530	240	265	60	2	249	262	RNA 4848
	LRT 24026580	6 000	240	265	80	2.1	251	262	RNA 4948
260	LRT 26028560	4 930	260	285	60	2	269	282	RNA 4852
	LRT 260290100	9 900	260	290	100	2.1	271	287	RNA 4952
280	LRT 28030569	6 050	280	305	69	2	289	302	RNA 4856
	LRT 280310100	10 600	280	310	100	2.1	291	307	RNA 4956
300	LRT 30033080	9 100	300	330	80	2.1	311	327	RNA 4860
	LRT 300340118	18 000	300	340	118	3	313	337	RNA 4960
320	LRT 32035080	9 600	320	350	80	2.1	331	347	RNA 4864
	LRT 320360118	19 200	320	360	118	3	333	357	RNA 4964

Note⁽¹⁾ Minimum allowable value of chamfer dimension r
Remark No oil hole is provided.

Shaft dia. mm	Identification number	Mass (Ref.) g	Boundary dimensions mm				Standard mounting dimension mm		Assembled bearings
			d	F	B	⁽¹⁾ r _{s min}	Min.	Max.	
340	LRT 34037080	10 200	340	370	80	2.1	351	367	RNA 4868
	LRT 340380118	20 300	340	380	118	3	353	377	RNA 4968
360	LRT 36039080	10 800	360	390	80	2.1	371	387	RNA 4872
	LRT 360400118	21 500	360	400	118	3	373	397	RNA 4972
380	LRT 380415100	16 700	380	415	100	2.1	391	412	RNA 4876
	LRT 380430140	33 900	380	430	140	4	396	427	RNA 4976
400	LRT 400450140	35 600	400	450	140	4	416	447	RNA 4980
420	LRT 420470140	37 300	420	470	140	4	436	467	RNA 4984
440	LRT 440490160	44 100	440	490	160	4	456	487	RNA 4988

Note⁽¹⁾ Minimum allowable value of chamfer dimension r
Remark No oil hole is provided.

H

IRT
IRB
LRT
LRB

INNER RINGS

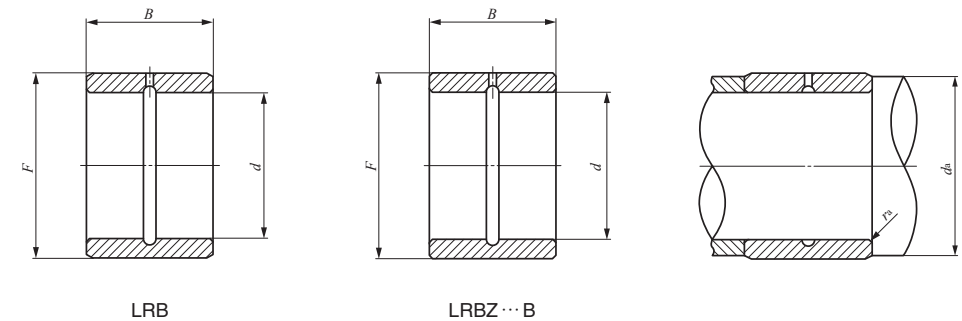
Inner Rings for General Usage **Inch Series**



Shaft dia. 9.525 – 22.225mm

Shaft dia. mm (inch)	Identification number		Mass (Ref.) g	Boundary dimensions mm(inch)			Standard mounting dimensions mm ⁽¹⁾		
				<i>d</i>	<i>F</i>	<i>B</i>	<i>d_a</i>		<i>r_{as max}</i>
							Min.	Max.	Max.
9.525 (³ / ₈)	LRB 61012	—	18.5	9.525 (³ / ₈)	15.875 (⁵ / ₈)	19.300	14	14.5	0.6
	—	LRBZ 61016 B	25	9.525 (³ / ₈)	15.875 (⁵ / ₈)	25.650	14	14.5	0.6
12.700 (¹ / ₂)	LRB 81212	—	23.5	12.700 (¹ / ₂)	19.050 (³ / ₄)	19.300	17.5	18	1
	LRB 81216	—	31	12.700 (¹ / ₂)	19.050 (³ / ₄)	25.650	17.5	18	1
	—	LRBZ 81216 B	31	12.700 (¹ / ₂)	19.050 (³ / ₄)	25.650	17.5	18	0.6
15.875 (⁵ / ₈)	LRB 101412	—	28	15.875 (⁵ / ₈)	22.225 (⁷ / ₈)	19.300	21	21.2	1
	LRB 101416	—	37.5	15.875 (⁵ / ₈)	22.225 (⁷ / ₈)	25.650	21	21.2	1
	—	LRBZ 101416 B	37.5	15.875 (⁵ / ₈)	22.225 (⁷ / ₈)	25.650	21	21.2	0.6
19.050 (³ / ₄)	LRB 121612	—	33	19.050 (³ / ₄)	25.400 (1)	19.300	24	24.4	1
	LRB 121616	—	44	19.050 (³ / ₄)	25.400 (1)	25.650	24	24.4	1
	—	LRBZ 121616 B	44	19.050 (³ / ₄)	25.400 (1)	25.650	24	24.4	0.6
22.225 (⁷ / ₈)	LRB 141816	—	50	22.225 (⁷ / ₈)	28.575 (1 ¹ / ₈)	25.650	27	27.5	1
	LRB 141820	—	62	22.225 (⁷ / ₈)	28.575 (1 ¹ / ₈)	32.000	27	27.5	1
	—	LRBZ 141820 B	62	22.225 (⁷ / ₈)	28.575 (1 ¹ / ₈)	32.000	27	27.5	0.6

Note(1) Maximum allowable fillet corner radius of shaft
 Remark LRB and LRBZ...B are provided with an oil groove and an oil hole.



Assembled bearings
BR 101812 BR 101816UU
BR 122012 BR 122016 BR 122016UU
BR 142212 BR 142216 BR 142216UU
BR 162412 BR 162416 BR 162416UU

- BR 182616**
- BR 182620**
- BR 182620UU**

H
 IRT
 IRB
 LRT
 LRB

INNER RINGS

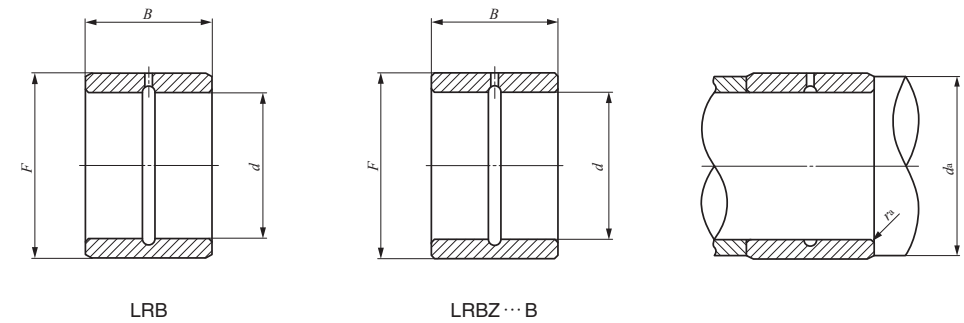
Inner Rings for General Usage **Inch Series**



Shaft dia. 25.400 — 38.100mm

Shaft dia. mm (inch)	Identification number		Mass (Ref.) g	Boundary dimensions mm(inch)			Standard mounting dimensions mm ⁽¹⁾		
				<i>d</i>	<i>F</i>	<i>B</i>	<i>d_a</i>		<i>r_{as}</i> max
						Min.	Max.	Max.	
25.400 (1)	LRB 162016	—	56	25.400 (1)	31.750 (1 1/4)	25.650	30.5	30.7	1
	LRB 162020	—	72	25.400 (1)	31.750 (1 1/4)	32.000	30.5	30.7	1
	—	LRBZ 162020 B	72	25.400 (1)	31.750 (1 1/4)	32.000	30.5	30.7	0.6
28.575 (1 1/8)	LRB 182216	—	63	28.575 (1 1/8)	34.925 (1 3/8)	25.650	33.5	33.9	1
	LRB 182220	—	77	28.575 (1 1/8)	34.925 (1 3/8)	32.000	33.5	33.9	1
	—	LRBZ 182220 B	77	28.575 (1 1/8)	34.925 (1 3/8)	32.000	33.5	33.9	0.6
31.750 (1 1/4)	LRB 202416	—	71	31.750 (1 1/4)	38.100 (1 1/2)	25.650	37	37.1	1.5
	LRB 202420	—	86	31.750 (1 1/4)	38.100 (1 1/2)	32.000	37	37.1	1.5
	—	LRBZ 202420 B	86	31.750 (1 1/4)	38.100 (1 1/2)	32.000	37	37.1	0.6
34.925 (1 3/8)	LRB 222616	—	77	34.925 (1 3/8)	41.275 (1 5/8)	25.650	40.2	40.2	1.5
	LRB 222620	—	96	34.925 (1 3/8)	41.275 (1 5/8)	32.000	40.2	40.2	1.5
	—	LRBZ 222620 B	96	34.925 (1 3/8)	41.275 (1 5/8)	32.000	40.2	40.2	0.6
38.100 (1 1/2)	LRB 242816	—	80	38.100 (1 1/2)	44.450 (1 3/4)	25.650	43.3	43.4	1.5
	LRB 242820	—	100	38.100 (1 1/2)	44.450 (1 3/4)	32.000	43.3	43.4	1.5
	LRB 243020	—	155	38.100 (1 1/2)	47.625 (1 7/8)	32.000	43.3	45	1.5
	—	LRBZ 242820 B	100	38.100 (1 1/2)	44.450 (1 3/4)	32.000	43.3	43.4	0.6
	—	LRBZ 243020 B	160	38.100 (1 1/2)	47.625 (1 7/8)	32.000	43.3	45	1

Note⁽¹⁾ Maximum allowable fillet corner radius of shaft
 Remark LRB and LRBZ...B are provided with an oil groove and an oil hole.



Assembled bearings	
BR 202816	
BR 202820	
BR 202820UU	
BR 223016	
BR 223020	
BR 223020UU	
BR 243316	
BR 243320	
BR 243320UU	
BR 263516	
BR 263520	
BR 263520UU	
BR 283716	
BR 283720	BR 283820
BR 303920	
BR 283720UU	
BR 303920UU	

H

IRT
IRB
LRT
LRB

INNER RINGS

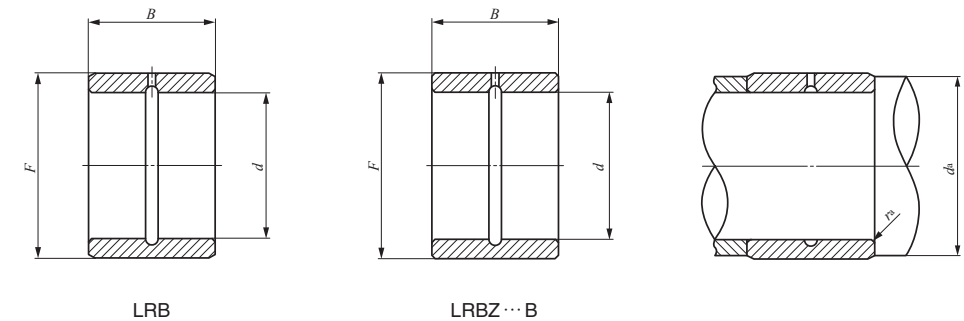
Inner Rings for General Usage Inch Series



Shaft dia. 41.275 – 63.500mm

Shaft dia. mm (inch)	Identification number		Mass (Ref.) g	Boundary dimensions mm(inch)			Standard mounting dimensions mm ⁽¹⁾		
				<i>d</i>	<i>F</i>	<i>B</i>	<i>d_a</i>		<i>r_{as max}</i>
						Min.	Max.	Max.	
41.275 (1 5/8)	LRB 263216	—	135	41.275 (1 5/8)	50.800 (2)	25.650	48	49	1.5
	LRB 263220	—	170	41.275 (1 5/8)	50.800 (2)	32.000	48	49	1.5
	—	LRBZ 263220 B	170	41.275 (1 5/8)	50.800 (2)	32.000	48	49	1
44.450 (1 3/4)	LRB 283624	—	300	44.450 (1 3/4)	57.150 (2 1/4)	38.350	52.5	55	1.5
	LRB 283628	—	345	44.450 (1 3/4)	57.150 (2 1/4)	44.700	52.5	55	1.5
	—	LRBZ 283628 B	345	44.450 (1 3/4)	57.150 (2 1/4)	44.700	52.5	55	1.5
50.800 (2)	LRB 324024	—	335	50.800 (2)	63.500 (2 1/2)	38.350	58	61	2
	LRB 324028	—	390	50.800 (2)	63.500 (2 1/2)	44.700	58	61	2
	—	LRBZ 324028 B	390	50.800 (2)	63.500 (2 1/2)	44.700	58	61	1.5
57.150 (2 1/4)	LRB 364424	—	375	57.150 (2 1/4)	69.850 (2 3/4)	38.350	65	67	2
	LRB 364428	—	440	57.150 (2 1/4)	69.850 (2 3/4)	44.700	65	67	2
	—	LRBZ 364428 B	440	57.150 (2 1/4)	69.850 (2 3/4)	44.700	65	67	1.5
63.500 (2 1/2)	LRB 404824	—	410	63.500 (2 1/2)	76.200 (3)	38.350	71	73	2
	LRB 404828	—	480	63.500 (2 1/2)	76.200 (3)	44.700	71	73	2
	—	LRBZ 404828 B	480	63.500 (2 1/2)	76.200 (3)	44.700	71	73	1.5

Note(1) Maximum allowable fillet corner radius of shaft
 Remark LRB and LRBZ...B are provided with an oil groove and an oil hole.



Assembled bearings	
BR 324116	
BR 324120	
BR 324120UU	
BR 364824	
BR 364828	
BR 364828UU	
BR 405224	
BR 405228	
BR 405228UU	
BR 445624	
BR 445628	
BR 445628UU	

BR 486024	
BR 486028	
BR 486028UU	

H
 IRT
 IRB
 LRT
 LRB

INNER RINGS

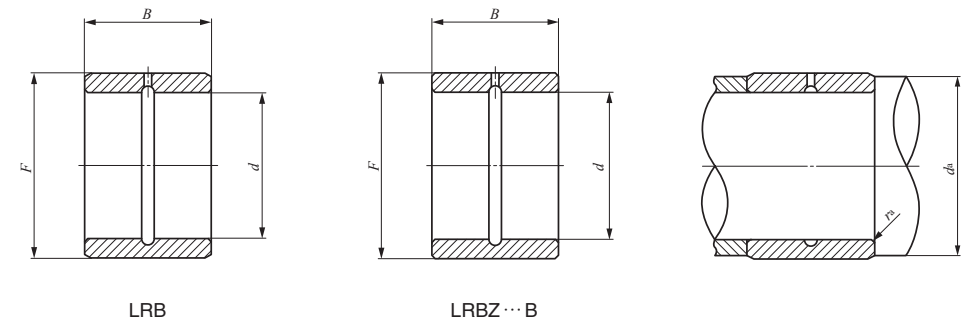
Inner Rings for General Usage **Inch Series**



Shaft dia. 69.850 – 88.900mm

Shaft dia. mm (inch)	Identification number		Mass (Ref.) g	Boundary dimensions mm(inch)			Standard mounting dimensions mm ⁽¹⁾		
				<i>d</i>	<i>F</i>	<i>B</i>	<i>d_a</i>		<i>r_{as max}</i>
						Min.	Max.	Max.	
69.850 (2 3/4)	LRB 445228	—	530	69.850 (2 3/4)	82.550 (3 1/4)	44.700	77	79	2
	LRB 445232	—	600	69.850 (2 3/4)	82.550 (3 1/4)	51.050	77	79	2
	—	LRBZ 445228 B	530	69.850 (2 3/4)	82.550 (3 1/4)	44.700	77	79	1.5
76.200 (3)	LRB 485632	—	640	76.200 (3)	88.900 (3 1/2)	51.050	83.5	86	2
	—	LRBZ 485632 B	640	76.200 (3)	88.900 (3 1/2)	51.050	83.5	86	1.5
82.550 (3 1/4)	LRB 526032	—	690	82.550 (3 1/4)	95.250 (3 3/4)	51.050	91	93	2.5
	—	LRBZ 526032 B	690	82.550 (3 1/4)	95.250 (3 3/4)	51.050	91	93	1.5
88.900 (3 1/2)	LRB 566432	—	750	88.900 (3 1/2)	101.600 (4)	51.050	97	99	2.5

Note(1) Maximum allowable fillet corner radius of shaft
 Remark LRB with inner ring bore diameter *d* of 76.200 mm or less and LRBZ...B are provided with an oil groove and an oil hole.
 Other models are provided with an oil groove and two oil holes.



Assembled bearings	
BR 526828	
BR 526832	
BR 526828UU	
BR 567232	
BR 567232UU	
BR 607632	
BR 607632UU	
BR 648032	

H
 IRT
 IRB
 LRT
 LRB

CAM FOLLOWERS

- Standard Type Cam Followers
- Stainless Steel Made Cam Followers
- Eccentric Type Cam Followers
- Solid Eccentric Stud Type Cam Followers
- Thrust Disk Type Cam Followers
- Centralized Lubrication Type Cam Followers
- Easy Mounting Type Cam Followers
- Cam Follower G
- C-Lube Cam Followers
- Short Stud Type Cam Followers
- Miniature Type Cam Followers
- Stainless Steel Made Miniature Cam Followers
- Thrust Disk Type Miniature Cam Followers
- Cylindrical Roller Cam Followers
- Inch series Cam Followers



Structure and Features

IKO Cam Followers are bearings with a stud incorporating needle rollers in a thick walled outer ring. These bearings are designed for outer ring rotation, and have superior rotational performance with a small coefficient of friction and high load capacity.

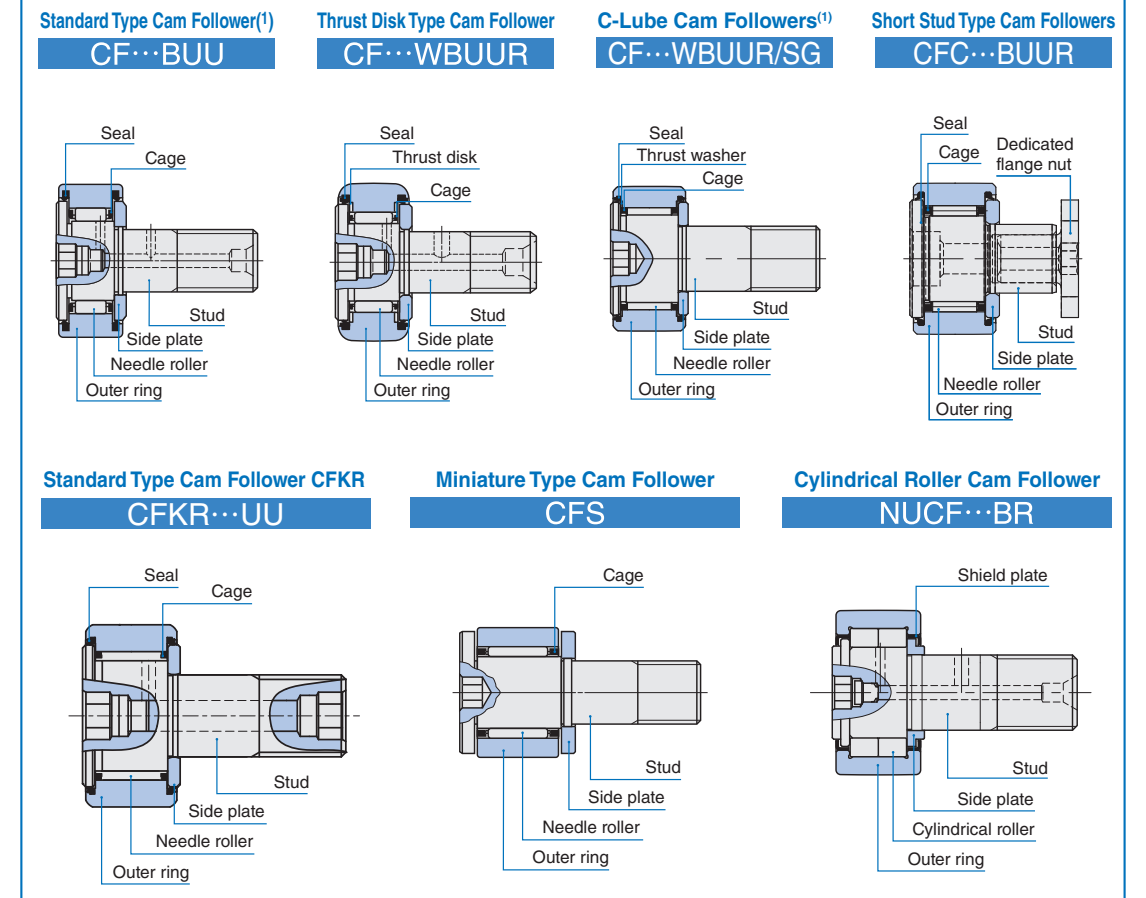
As studs already have threads or steps, they are easy to mount.

Cam Followers are follower bearings for cam mechanisms and linear motions and have high rigidity and

high accuracy. They are, therefore, used widely for machine tools, industrial robots, electronic devices, and OA equipment.

Stainless steel made Cam Followers are superior in corrosion resistance and suitable for applications in environments where oil cannot be used or water splashed, and in clean rooms.

Structure of Cam Followers



Note⁽¹⁾ Thermosetting solid-type lubricant C-Lube fills inner space of the bearing.

I
CF
CFKR
CFS
NUCF
CR

For Cam Followers, the types shown in Table 1 are available.

Table 1 Type of Cam Followers

Bearing Model		Item	Shield type	With cage		Full complement	
				Crowned outer ring	Cylindrical outer ring	Crowned outer ring	Cylindrical outer ring
Standard Type Cam Follower CF...B CFKR	High carbon steel made	Stud Head Hex Hole	Shield type	CF ... B R	CF ... B	CF ...V B R	CF ... V B
			Sealed type	CF ... B UUR	CF ... B UU	CF ...V B UUR	CF ... V B UU
	Stainless steel made	Stud Head Hex Hole	Shield type	CF ...F B R	CF ...F B	—	—
			Sealed type	CF ...F B UUR	CF ...F B UU	—	—
	High carbon steel made	Double Hex Hole	Shield type	CFKR... R	CFKR	CFKR...V R	CFKR... V
			Sealed type	CFKR... UUR	CFKR ... UU	CFKR...V UUR	CFKR... V UU
Eccentric Type Cam Followers CFE...B CFKRE	High carbon steel made	Stud Head Hex Hole	Shield type	CFE ... B R	CFE ... B	CFE ...V B R	CFE ... V B
			Sealed type	CFE ... B UUR	CFE ... B UU	CFE ...V B UUR	CFE ... V B UU
		Double Hex Hole	Shield type	CFKRE ... R	CFKRE	CFKRE...V R	CFKRE... V
			Sealed type	CFKRE ... UUR	CFKRE ... UU	CFKRE...V UUR	CFKRE... V UU
Solid Eccentric Stud Type Cam Followers CFES...B	High carbon steel made	With hexagon hole	Shield type	CFES... B R	CFES... B	—	—
			Sealed type	CFES... B UUR	CFES... B UU	—	—
Thrust Disk Type Cam Followers CF...WB	High carbon steel made	With hexagon hole	Shield type	CF ... WB R	—	—	—
			Sealed type	CF ... WB UUR	—	—	—
	Stainless steel made		Shield type	CF ...F WB R	—	—	—
			Sealed type	CF ...F WB UUR	—	—	—
Centralized Lubrication Type Cam Followers CF-RU1, CF-FU1	High carbon steel made	With screwdriver slot	Sealed type	CF-RU1	CF-FU1	—	—
Easy Mounting Type Cam Followers CF-SFU...B	High carbon steel made	With hexagon hole	Sealed type	—	CF-SFU... B	—	—
Cam Follower G CF...G	High carbon steel made	With hexagon hole	Shield type	—	CF ...G	—	—
C-Lube Cam Followers CF...WB.../SG	High carbon steel made	With hexagon hole	Sealed type	CF ...WB.../SG	—	—	—
Short Stud Type Cam Followers CFC...B	High carbon steel made	Hexagon socket head bolt included	Sealed type	CF ... B UUR	—	CFC ...V B UUR	—
		Hexagon socket head flange nut included	Sealed type	CF ... B UUR	—	CFC ...V B UUR	—
Miniature Type Cam Followers CFS	High carbon steel made	With hexagon hole	Shield type	—	CFS	—	CFS ... V
	Stainless steel made		Shield type	—	CFS ...F	—	CFS ...F V
Thrust Disk Type Miniature Cam Followers CFS...W	High carbon steel made	With hexagon hole	Shield type	—	CFS ... W	—	CFS ...WV
	Stainless steel made		Shield type	—	CFS ...F W	—	—
Cylindrical Roller Cam Followers NUCF...B	High carbon steel made	With hexagon hole	Shield type	—	—	NUCF... B R	—
Inch series Cam Followers CR	High carbon steel made	With hexagon hole	Shield type	CR ... B R	CR ...B	CR ...V B R	CR ... V B
			Sealed type	CR ... B UUR	CR ...B UU	CR ...V B UUR	CR ... V B UU
		With screwdriver slot	Sealed type with ThrustDisk Seals™	—	—	CR ...V B S R	CR ... V B S
			Shield type	CR ... R	CR	CR ...V R	CR ... V
Inch series Cam Followers CRH...B	High carbon steel made	With hexagon hole	Sealed type	CR ... UUR	CR ... UU	CR ...V UUR	CR ... V UU
			Shield type	—	—	CRH...V B R	CRH... V B
			Sealed type	—	—	CRH...V B UUR	CRH... V B UU

Standard Type Cam Followers

These are the basic type bearings in IKO Cam Follower series. Standard Type Cam Followers CF...B with stud diameters ranging from 3 mm to 30 mm are available, and are suitable for a wide range of applications. Standard Type Cam Followers CFKR have sockets with hexagon holes on both stud ends, which allow mounting with a hexagon wrench from either side.

Eccentric Type Cam Followers

The eccentric stud can be rotated to create a uniform line, enabling easy adjustment for even load distribution across the outer ring outer surface. Eccentricity is 0.4 (CFE) ~ 1.5 mm.

Solid Eccentric Stud Type Cam Followers

The eccentric stud can be rotated to create a uniform line, enabling easy adjustment for even load distribution across the outer ring outer surface. These are eccentric cam followers with an integrated stud that can be mounted in the same mounting holes as those for Standard Type Cam Followers. Eccentricity is from 0.25 mm to 0.6 mm.

Thrust Disk Type Cam Followers

The thrust disk seal, made of special synthetic resin with excellent abrasion and heat resistance, is incorporated in the sliding contact area between the shoulders of the outer ring and the stud head and side plate. This prevents friction and abrasion inside the bearing due to axial loads caused by mounting errors.

Centralized Lubrication Type Cam Followers

These bearings have one or two pipe-threaded holes in the stud. Thus, this series is suitable when centralized lubrication is required.

Easy Mounting Type Cam Followers

These bearings have a stepped tapered portion on the stud. When mounting the Cam Follower, it is easy to fix its location by tightening a set screw to the stepped portion. Thus, this type is suitable when a large number of Cam Followers are used in a machine such as a pallet changer.

C-Lube Cam Followers

These bearings are lubricated with a newly developed thermosetting solid-type lubricant which fills the inner space of the bearing. This lubricant provides long-term maintenance free.

Short Stud Type Cam Followers

These Cam Followers feature a more compact size and easier mounting structure than standard-type Cam Followers and require significantly less mounting space while maintaining the same level of performance. This allows for greater design freedom, which contributes to reducing machine size and improving production efficiency.

Miniature Type Cam Followers

These are compactly designed bearings, incorporating very thin needle rollers in an outer ring with a small outside diameter. They are used in electronic devices, OA equipment, small index devices, etc.

Cylindrical Roller Cam Followers

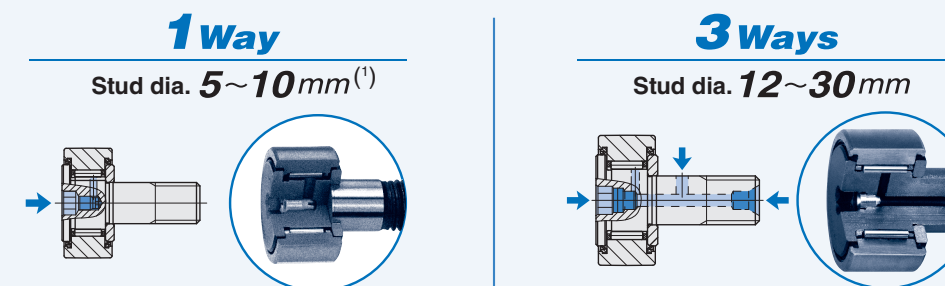
These bearings are full complement type bearings incorporating double rows of full complement cylindrical rollers in the outer ring, and can withstand large radial loads. Additionally, the outer ring is guided by the outer ring shoulder and the end face of cylindrical rollers to the axial direction.

Inch series Cam Followers

Two types, CR and CRH, are available in the Inch series Cam Followers. Black oxide film treatment is made on CRH models. CR with ThrustDisk Seals™ prevents the ingress of foreign substances as well as friction and abrasion on the interior of the bearing caused by axial load generated due to mounting errors.

Lubrication method of Hex Head Cam Followers

(Types) Standard Type, Eccentric Type, Solid Eccentric Stud Type, Thrust Disk Type, Easy Mounting Type, Cylindrical Roller Type.



Remark : All Easy Mounting Type have a 1way port.
Note (1) CFKR and CFKRE can be lubricated from both head part and thread side.
Also, a grease nipple is built into the stud head.

1N=0.102kgf=0.2248lbs.
1mm=0.03937inch

I
CF
CFKR
CFS
NUCF
CR

Internal Structures and Shapes

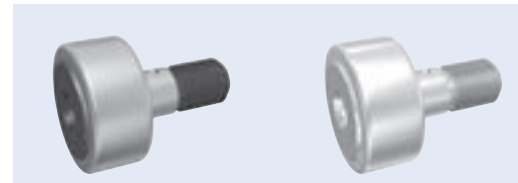
The Cam Follower series has various types, such as high carbon steel type, stainless steel type, caged type, full complement type, shield type, sealed type,

type with crowned outer ring, type with cylindrical outer ring, etc.

Type of material

In addition to high carbon steel products, stainless steel products are also available. Stainless steel products are suited for applications where oil cannot be used or where water splashes, and in cleanrooms.

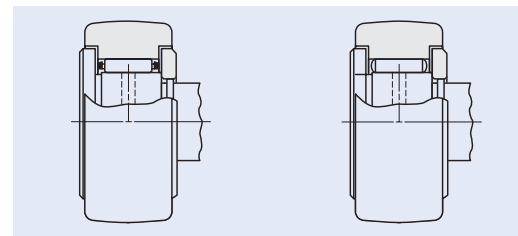
«High carbon steel made» «Stainless steel made»



Roller guide method

Cam Followers include the caged type and the full complement type. The caged type has a small coefficient of friction and is suitable for high speed rotations, while the full complement type is suitable for heavy loads at low speed rotations.

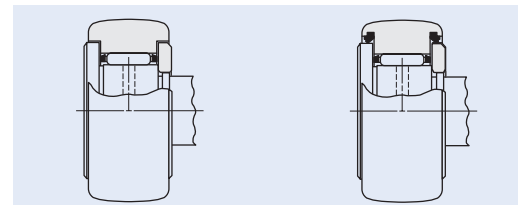
«With cage» «Full complement»



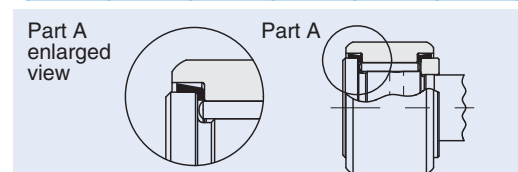
Seal structure

Available Cam Followers include the shield type, the sealed type, and type with ThrustDisk Seals™. In the shield type, labyrinths are formed by the narrow clearances between the outer ring and the stud flange, and between the outer ring and the side plate. The sealed type incorporates seals in the narrow clearances (the shield type labyrinths) to prevent the ingress of foreign substances. The sealed type with ThrustDisk Seals™ prevents grease leakage and the ingress of foreign substances into the bearing interior. It also prevents friction and abrasion on the interior of the bearing caused by axial load generated due to mounting errors.

«Shield type» «Sealed type»



«Sealed type with ThrustDisk Seals™» (1)

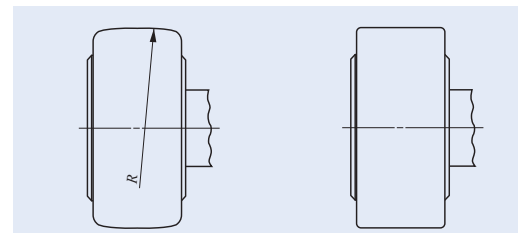


Notes(1) Applicable only to Inch Series Cam Followers CR (Stud Head Hex Hole)

Shape of outer ring outside surface

The outside surface of the outer ring of Cam Followers, which makes direct contact with the mating cam guide surface, is either crowned or cylindrical. The crowned outer rings are effective in moderating the edge load due to mounting errors. The cylindrical outer rings have a large contact area with the mating cam guide surface, and are suitable for applications in which the applied load is large or the cam guide surface hardness is low.

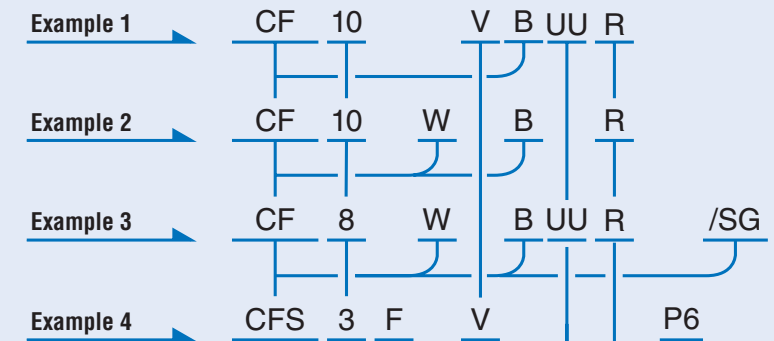
«Crowned outer ring» «Cylindrical outer ring»



Identification number

Some examples of the identification number of Cam Followers are shown below. For applicable material symbol, roller guide method, seal structure and shape of outer ring outside surface, refer dimension table of each series.

Examples of identification number



Model code	
CF...B	Standard Type Cam Follower(Stud Head Hex Hole)
CFKR	Standard Type Cam Follower(Double Hex Hole)
CFE...B	Eccentric Type Cam Followers(Stud Head Hex Hole)
CFKRE	Eccentric Type Cam Followers(Double Hex Hole)
CFES...B	Solid Eccentric Stud Type Cam Followers
CF...WB	Thrust Disk Type Cam Followers
CF-RU1	Centralized Lubrication Type Cam Followers(Crowned outer ring)
CF-FU1	Centralized Lubrication Type Cam Followers(Cylindrical outer ring)
CF-SFU...B	Easy Mounting Type Cam Followers
CF...G	Cam Follower G
CF...WB.../SG	C-Lube Cam Followers
CFC...B	Short Stud Type Cam Followers
CFS	Miniature Type Cam Followers
CFS...W	Thrust Disk Type Miniature Cam Followers
NUCF...B	Cylindrical Roller Cam Followers
CR	Inch series Cam Followers(With screwdriver slot)
CR...B	Inch series Cam Followers(Stud Head Hex Hole)
CRH...B	Inch series Cam Followers(Stud Head Hex Hole)

Size
The value indicates a stud diameter. (unit: mm)
For Double Hex Hole Cam Followers, the outside diameter of the outer ring is indicated.
In the inch series, the outside diameter of the outring in units of 1/16 inch is indicated.

Material	
No symbol	High carbon steel made
F	Stainless steel made

Roller guide method	
No symbol	With cage type
V	Full complement type

Seal structure	
No symbol	Shield type
UU	Sealed type
S(1)	Sealed type with ThrustDisk Seals™

Notes(1) Applicable only to Inch Series Cam Followers CR (Stud Head Hex Hole)

Shape of outer ring outside surface	
R	With crowned outer ring
No symbol	With cylindrical outer ring

Classification symbol		
No symbol	Class 0	
P6	Class 6	Applicable to Miniature CFS series
P5	Class 5	
P4	Class 4	

I
CF
CFKR
CFS
NUCF
CR

Accuracy

The accuracy of Cam Followers is shown in Table 2, Table 3.1, Table 3.2 and Table 3.3. Cam Followers with special accuracy are also available. When they are required, please contact IKO.

Table 2 Tolerances

unit: μm

Series	Metric CF (1)		Miniature series CF	Inch series CF	
	Crowned outer ring	Cylindrical outer ring		Crowned outer ring	Cylindrical outer ring
Dimensions and symbols					
Outside dia. of outer ring D	0 -50	See Table 3.1	See Table 3.2	0 -50	See Table 3.3
Stud dia. d_1	h7		h6	+25 0	
Width of outer ring C	0 -120		0 -120	0 -130	

Note(1) Applicable to Cam Followers other than Miniature Type Cam Followers and Inch Series Cam Followers.

Table 3.1 Tolerances and allowable values of outer rings (Metric CF cylindrical outer rings(1))

unit: μm

D Nominal outside dia. of outer ring mm		Δ_{Dmp} Single plane mean outside dia. deviation		V_{Dsp} Outside dia. variation in a single radial plane (Max.)	V_{Dmp} Mean outside dia. variation (Max.)	K_{ca} Radial runout of assembled bearing outer ring (Max.)
Over	Incl.	High	Low			
6	18	0	- 8	10	6	15
18	30	0	- 9	12	7	15
30	50	0	-11	14	8	20
50	80	0	-13	16	10	25
80	120	0	-15	19	11	35

Note(1) Applicable to Cam Followers other than Miniature Type Cam Followers and Inch Series Cam Followers.

Table 3.2 Tolerances and allowable values of outer rings (Miniature series CF)

unit: μm

Δ_{Dmp} Single plane mean outside dia. deviation								K_{ca} Radial runout of assembled bearing outer ring (Max.)			
Class 0		Class 6		Class 5		Class 4		Class 0	Class 6	Class 5	Class 4
High	Low	High	Low	High	Low	High	Low				
0	-8	0	-7	0	-5	0	-4	15	8	5	4

Table 3.3 Tolerances and allowable values of outer rings (Inch series CF cylindrical outer ring)

unit: μm

D Nominal outside dia. of outer ring mm		Δ_{Dmp} Single plane mean outside dia. deviation		V_{Dsp} Outside dia. variation in a single radial plane (Max.)	V_{Dmp} Mean outside dia. variation (Max.)	K_{ca} Radial runout of assembled bearing outer ring (Max.)
Over	Incl.	High	Low			
6	18	0	-25	10	6	15
18	30			12	7	15
30	50			14	8	20
50	80			16	10	25
80	120			19	11	35

Clearance

The radial internal clearances of Cam Followers are shown in Table 4.

Table 4 Radial internal clearance

unit: μm

Metric CF series (2)	Miniature CFS series CF (3)	Identification number (1)		Radial internal clearance	
		Cylindrical Roller Cam Followers NUCF...B	Inch series CF	Min.	Max.
CF 3~CF 5	CFS1.4 ~CFS5	—	CR 8, CR 8-1, CRH 8-1, CRH 9	3	17
CF 6	CFS6	—	CR10, CR10-1, CRH10-1, CRH11	5	20
CF 8~CF12-1 CFKR22~CFKR32	—	—	CR12~CR22, CRH12~CRH22	5	25
CF16~CF20-1 CFKR35~CFKR52	—	—	CR24~CR36, CRH24~CRH36	10	30
CF24~CF30-2 CFKR62~CFKR90	—	—	CR48, CRH40~CRH56	10	40
—	—	—	CRH64	15	50
—	—	NUCF10 R~NUCF24 R	—	20	45
—	—	NUCF24-1R~NUCF30-2R	—	25	50

Note(1) Also applicable to full complement type, type with crowned outer ring, sealed type, and type with hexagon hole.

(2) Applicable to all Cam Followers other than Miniature Type Cam Followers, Cylindrical Roller Cam Followers and Inch Series Cam Followers.

(3) Applicable to all Miniature Type Cam Followers.

Fit

Tables 5 and 6 show recommended tolerances of mounting holes for Cam Follower studs. Since the Cam Follower is supported in a cantilever position, the mounting hole diameter should be prepared without play between the stud and the hole especially when heavy shock loads are applied.

Table 5 Recommended fit

Type	Tolerance class of mounting hole for stud
Metric CF	H7
Miniature series CF	H6
Cylindrical Roller Cam Followers	H7
Inch series CF	F7

Table 6 Dimensional tolerances of mounting hole

unit: μm

Nominal outside dia. of stud mm		F7		H6		H7	
Over	Incl.	Over	Incl.	Over	Incl.	Over	Incl.
—	3	+16	+ 6	+ 6	0	+10	0
3	6	+22	+10	+ 8	0	+12	0
6	10	+28	+13	+ 9	0	+15	0
10	18	+34	+16	+11	0	+18	0
18	30	+41	+20	+13	0	+21	0
30	50	+50	+25	+16	0	+25	0

Maximum Allowable Static Load

The applicable load on Cam Followers is, in some cases, limited by the bending strength and shear strength of the stud and the strength of the outer ring instead of the load rating of the needle roller bearing. Therefore, the maximum allowable static load that is limited by these strengths is specified.

Track Capacity

Track capacity is defined as the load which can be continuously applied on a Cam Follower placed on a steel cam guide surface without causing deformation or indentation on the cam guide surface when the outer ring of the Cam Follower makes contact with the mating cam guide surface (plane). The track capacities shown in Tables 7.1 and 7.2 are applicable when the hardness of the mating cam guide surface is 40HRC (Tensile strength 1250N/mm²). When the hardness of the mating cam guide surface differs from 40HRC, the track capacity is obtained by multiplying the value by the track capacity factor shown in Table 8.

If lubrication between the outer ring and the mating cam guide surface is insufficient, seizure and/or wear may occur depending on the application. Therefore, attention must be paid to lubrication and surface roughness of the mating cam guide especially for high-speed rotations such as cam mechanisms.

For lubrication between the outer ring and the mating cam guide surface, C-Lube Unit for Cam Followers is recommended. (See page I20.)

Table 7.1 Track load capacity

unit: N

Type of bearing	Identification number with crowned outer ring	Track capacity	Identification number with cylindrical outer ring	Track capacity
Metric CF ⁽¹⁾	CF 3 R	542	CF 3	1 360
	CF 4 R	712	CF 4	1 790
	CF 5 R	794	CF 5	2 210
	CF 6 R	1 040	CF 6	3 400
	CF 8 R	1 330	CF 8	4 040
	CF10 R · CFKR22R	1 610	CF10 · CFKR22	4 680
	CF10-1R · CFKR26R	2 030	CF10-1 · CFKR26	5 530
	CF12 R · CFKR30R	2 470	CF12 · CFKR30	7 010
	CF12-1R · CFKR32R	2 710	CF12-1 · CFKR32	7 480
	CF16 R · CFKR35R	3 060	CF16 · CFKR35	11 200
	CF18 R · CFKR40R	3 660	CF18 · CFKR40	14 500
	CF20 R · CFKR52R	5 190	CF20 · CFKR52	23 200
	CF20-1R · CFKR47R	4 530	CF20-1 · CFKR47	21 000
	CF24 R · CFKR62R	6 580	CF24 · CFKR62	34 300
	CF24-1R · CFKR72R	8 020	CF24-1 · CFKR72	39 800
	CF30 R · CFKR80R	9 220	CF30 · CFKR80	52 700
	CF30-1R · CFKR85R	9 990	CF30-1 · CFKR85	56 000
	CF30-2R · CFKR90R	10 800	CF30-2 · CFKR90	59 300
Miniature series CF ⁽²⁾	—	—	CFS1.4	128
	—	—	CFS2	220
	—	—	CFS2.5	298
	—	—	CFS3	485
	—	—	CFS4	799
	—	—	CFS5	1 210
—	—	CFS6	1 680	

Notes⁽¹⁾ Applicable to Cam Followers other than Miniature Type Cam Followers and Inch Series Cam Followers.

⁽²⁾ This table is applicable to all Miniature Type Cam Followers.

Table 7.2 Track capacity

unit: N

Type of bearing	Identification number with crowned outer ring	Track capacity	Identification number with cylindrical outer ring	Track capacity	Identification number with crowned outer ring	Track capacity	Identification number with cylindrical outer ring	Track capacity
Inch series CF ⁽¹⁾	CR 8 R	770	CR 8	2 140	—	—	—	—
	CR 8-1R	770	CR 8-1	2 360	CRH 8-1R	401	CRH 8-1	2 360
	—	—	—	—	CRH 9 R	469	CRH 9	2 650
	CR10 R	1 030	CR10	3 210	—	—	—	—
	CR10-1R	1 030	CR10-1	3 480	CRH10-1R	579	CRH10-1	3 480
	—	—	—	—	CRH11 R	658	CRH11	3 830
	CR12 R	1 340	CR12	4 500	CRH12 R	853	CRH12	4 500
	CR14 R	1 630	CR14	5 250	CRH14 R	1 050	CRH14	5 250
	CR16 R	1 970	CR16	7 280	CRH16 R	1 420	CRH16	7 280
	CR18 R	2 300	CR18	7 710	CRH18 R	1 660	CRH18	7 710
	CR20 R	2 680	CR20	10 700	CRH20 R	2 160	CRH20	10 700
	CR22 R	3 050	CR22	11 800	CRH22 R	2 450	CRH22	11 800
	CR24 R	3 410	CR24	15 400	CRH24 R	3 410	CRH24	15 400
	CR26 R	3 820	CR26	16 700	CRH26 R	3 820	CRH26	16 700
	CR28 R	4 210	CR28	21 000	CRH28 R	4 210	CRH28	21 000
	CR30 R	4 610	CR30	22 500	CRH30 R	4 610	CRH30	22 500
	CR32 R	5 050	CR32	30 900	CRH32 R	5 690	CRH32	30 900
	CR36 R	5 900	CR36	34 700	CRH36 R	6 640	CRH36	34 700
	—	—	—	—	CRH40 R	8 970	CRH40	45 000
	—	—	—	—	CRH44 R	10 200	CRH44	49 500
—	—	CR48	64 300	CRH48 R	11 400	CRH48	64 300	
—	—	—	—	CRH52 R	12 700	CRH52	69 600	
—	—	—	—	CRH56 R	14 100	CRH56	87 000	
—	—	—	—	CRH64 R	16 800	CRH64	113 000	

Notes⁽¹⁾ This table is applicable to all Inch series CF.

Table 8 Track capacity factor

Hardness HRC	Tensile strength N/mm ²	Track capacity factor	
		With crowned outer ring	With cylindrical outer ring
20	760	0.22	0.37
25	840	0.31	0.46
30	950	0.45	0.58
35	1 080	0.65	0.75
38	1 180	0.85	0.89
40	1 250	1.00	1.00
42	1 340	1.23	1.15
44	1 435	1.52	1.32
46	1 530	1.85	1.51
48	1 635	2.27	1.73
50	1 760	2.80	1.99
52	1 880	3.46	2.29
54	2 015	4.21	2.61
56	2 150	5.13	2.97
58	2 290	6.26	3.39



Allowable Rotational Speed

The allowable rotational speed of Cam Followers is affected by mounting and operating conditions. For d_1n values with only pure radial load applied, use the maximum values in Table 9 or lower as a guideline. Under actual operating conditions, use the recommended d_1n values in Table 9 as a guideline in consideration of the effect of axial loads. For C-Lube Cam Followers, use a d_1n value of 10,000 or less as a guideline.

Table 9 d_1n values of Cam Followers⁽¹⁾

Type	Grease		Oil	
	Maximum	Recommended	Maximum	Recommended
Caged type	84 000	8 400	140 000	14 000
Full complement type	42 000	4 200	70 000	7 000
Cylindrical Roller Cam Follower	66 000	6 600	110 000	11 000
C-Lube Cam Followers	10 000		10 000	

Note⁽¹⁾ d_1n value = $d_1 \times n$
 where, d_1 ⁽²⁾: Stud diameter mm
 n : Rotational speed min⁻¹

⁽²⁾ For Eccentric Type Cam Followers, thread diameter G as shown in the dimension table is applicable.

Lubrication

Grease-prepacked Cam Followers are shown in Table 10. The lubricating grease prepacked in these bearings is ALVANIA GREASE S2 (Shell Lubricants Japan K.K.).

For Cam Followers without prepacked grease, grease should be packed through the oil hole in the stud for use. If they are used without grease, wear of rolling contact surfaces may take place, leading to a short bearing life.

Table 10 Bearings with prepacked grease

○ : Prepacked × : Not prepacked

Series Size of stud diameter d_1 ⁽¹⁾ mm	Item	With cage				Full complement
		Shield type		Sealed type		
		With hexagon hole	With screwdriver slot	With hexagon hole	With screwdriver slot	
Standard Type Cam Follower CF...B CFKR	3~ 5	○	-	○	-	-
Solid Eccentric Stud Type Cam Followers CFES...B Thrust Disk Type Cam Followers CF...WB	12~ 30	×	-	-	-	○
Easy Mounting Type Cam Followers CF-SFU...B	-	-	○	-	-	-
Cam Follower G CF...G	-	○	-	-	-	-
C-Lube Cam Followers CF...WB.../SG ⁽²⁾	-	-	-	×	-	-
Short Stud Type Cam Followers CFC...B	-	-	-	○ ⁽³⁾	-	○
Miniature Type Cam Followers CFS CFS...W	-	○	-	-	-	○
Cylindrical Roller Cam Followers NUCF...B	-	-	-	-	-	○
Inch series Cam Followers CR, CR...B CRH...B	-	○	○	○	○	○
	-	-	-	-	-	○

Notes⁽¹⁾ For Eccentric Type Cam Followers, thread diameter G as shown in the dimension table is applicable.

⁽²⁾ C-Lube, a thermosetting solid-type lubricant, fills the inner space of the bearing.

⁽³⁾ Short Stud Cam Followers are supplied with a hexagon socket head bolt and a dedicated flange nut (hexagon socket on head).

Oil Hole

The position of oil hole is shown in Table 11.

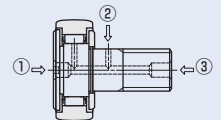
Perform greasing quietly by fitting a lubrication nozzle indicated in Table 12 to a straight type grease gun in JIS B 9808 and pressing the nozzle against the grease nipple or re-greasing fitting.

Due to their structures, lubrication is not possible for sizes 3 and 4 Standard Type Cam Followers CF...B, C-Lube Cam Followers, Cam Followers G, Short Stud Cam Followers CFC, and Miniature CFS series.

Table 11 Position of oil hole

○ : Oil hole is prepared.

Series		Oil hole position	① Head	② Stud outside surface	③ Stud end
Size of stud diameter d_1 ⁽¹⁾ mm					
Standard Type Cam Follower	CF...B	$d_1 < 5$	-	-	-
Eccentric Type Cam Followers	CFE...B	$5 \leq d_1 \leq 10$	○ ⁽³⁾	-	-
Solid Eccentric Stud Type Cam Followers	CFES...B				
Thrust Disk Type Cam Followers	CF...WB	$10 < d_1$	○ ⁽²⁾	○	○
Standard Type Cam Follower	CFKR	$d_1 \leq 10$	○ ⁽²⁾	-	○
Eccentric Type Cam Followers	CFKRE	$10 < d_1$	○ ⁽²⁾	○	○
Centralized Lubrication Type Cam Followers	CF-RU1, CF-FU1 ⁽⁴⁾	$d_1 \leq 12$	○	-	-
		$12 < d_1$	○	○	○
Easy Mounting Type Cam Followers	CF-SFU...B	$d_1 \leq 10$	○ ⁽³⁾	-	-
		$10 < d_1$	○ ⁽⁵⁾	-	-
Cam Follower G	CF...G		-	-	-
C-Lube Cam Followers	CF...WB.../SG		-	-	-
Short Stud Type Cam Followers	CFC...B		-	-	-
Miniature Type Cam Followers	CFS CFS...W		-	-	-
Cylindrical Roller Cam Followers	NUCF...B	$d_1 \leq 10$	○ ⁽³⁾	-	-
		$10 < d_1$	○ ⁽²⁾	○	○
Inch series Cam Followers	CR...B	With hexagon hole $d_1 \leq 6.35$	-	-	-
		With screwdriver slot $6.35 < d_1$	-	○	○
	CRH...B	With hexagon hole $d_1 \leq 6.35$	○	-	-
		With screwdriver slot $6.35 < d_1$	○	○	○
	With hexagon hole $d_1 \leq 7.938$	-	-	-	
	With screwdriver slot $7.938 < d_1$	-	○	○	



Notes⁽¹⁾ In case of Eccentric Type Cam Followers, thread diameter G shown in the table of dimensions is applicable in place of stud dia. and the oil hole on the outer surface of the stud cannot be used.

⁽²⁾ Grease nipple is incorporated in the hexagon hole. Re-greasing can be made from the stud head and the stud end by press fitting a supplied grease nipple into the stud end. See page 14.

⁽³⁾ Re-lubrication can be made from the re-greasing fitting that is inserted into the hexagon hole. See page 14.

⁽⁴⁾ Tapped holes for oil connectors are provided at the stud end and hole of the head.

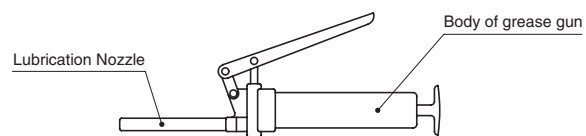
⁽⁵⁾ Re-greasing can be made from the grease nipple in the hexagon hole.

Table 12 Type and Dimension of Lubrication Nozzles

Type	Dimension	Applicable grease nipple and re-grease fitting
A-5126T		NPF3 ⁽¹⁾ NPF6-1 ⁽¹⁾ Re-grease fitting ⁽¹⁾
A-5120R		NPF4-1 ⁽¹⁾ NPF6-1 ⁽¹⁾
B-5120R		
A-5120V		NPT4-1 NPT6-1 NPB2 NPB3 NPB3-1 NPB4
A-5240V		
B-5120V		
B-5240V		

Note⁽¹⁾ HSP-3(Yamada Corporation)can be used for them.

Remark The above nozzles can be attached on the standard grease gun shown below.
If required, please consult to IKO with type of lubrication nozzle.



Accessories

Cam Follower accessories are shown in Table 13. Grease nipple dimensions are shown in Table 14 and Table 15. Dimensions of plug for unused oil hole and dimensions of plug inserter are shown in Table 16. Nut dimensions are shown in Table 17 and Table 18.

Table 13 Accessories

Series ⁽¹⁾ Size of stud dia. d_1 mm		Accessories	Grease nipple	Plug	Nut	Spring washer	Hexagon socket head bolt
Standard Type Cam Follower	CF...B	$d_1 \leq 10$	—	—	○	— ⁽²⁾	—
Eccentric Type Cam Followers	CFE...B		○	—	○	— ⁽²⁾	—
Solid Eccentric Stud Type Cam Followers	CFES...B			○	—	○	— ⁽²⁾
Thrust Disk Type Cam Followers	CF...WB		—		—	○	— ⁽²⁾
Standard Type Cam Follower	CFKR	○	○	—	○	— ⁽²⁾	—
Eccentric Type Cam Followers	CFKRE						
Centralized Lubrication Type Cam Followers	CF-RU1, CF-FU1	—	—	○	—	—	
Easy Mounting Type Cam Followers	CF-SFU...B	—	—	—	—	—	
Cam Follower G	CF...G	—	—	○	—	—	
C-Lube Cam Followers	CF...WB.../SG	—	—	○	—	—	
Short Stud Type Cam Followers	CFC...B	—	—	○ ⁽³⁾	—	○	
Miniature Type Cam Followers	CFS, CFS...W	—	—	○	—	—	
Cylindrical Roller Cam Followers	NUCF...B	$d_1 \leq 10$	—	—	○	—	—
		$10 < d_1$	○	—	○	—	—
Inch series Cam Followers	CR...B With hexagon hole	$d_1 \leq 6.35$	—	—	○	—	—
	CR With screwdriver slot	$6.35 < d_1$	○	○	○	—	—
	CRH...B With hexagon hole	$d_1 \leq 7.938$	—	—	○	—	—
		$7.938 < d_1$	○	○	○	—	—

Notes ⁽¹⁾ For Eccentric Type Cam Follower, thread diameter G is applied.

⁽²⁾ Eccentric Type Cam Followers are supplied with spring washers.

⁽³⁾ Short Stud Cam Followers come with a dedicated flange nut.

Remark: The standard grease nipple (brass) is included in the Stainless Steel Made Cam Follower.
When a stainless steel grease nipple is required, please contact IKO.

Table 14 Dimensions of grease nipple for Standard Type Cam Followers ⁽¹⁾

Identification number	Dimensions of grease nipple mm				Stud diameter d_1 ⁽²⁾ mm	Dimension of inserter mm d_0 ^{+0.05} _{-0.05}
	d	D	L	W		
NPF3 ⁽³⁾	3	4	4.5	1.3	10	4.1
NPF4-1	4	5	5	1.5	12~16	5.3
NPF6-1	6	7	8	2	18~30	7.3

Notes ⁽¹⁾ Applicable to Cam Followers other than Inch series Cam Followers.

⁽²⁾ For Eccentric Type Cam Followers, thread diameter G as shown in the dimension table is applicable.

⁽³⁾ Only applicable to Standard Type Cam Follower CFKR, and Eccentric Type Cam Follower CFKRE sizes 22 and 26.

Remark: The same grease nipple as the accessory is integrated in the hexagon hole on the head.

Table 15 Dimensions of grease nipple for Inch series Cam Followers

Identification number	Dimensions mm						Applicable Cam Followers
	d	D	D ₁	L	L ₁	W	
NPB2	3.18	7.5	6	9	5.5	1.5	CR8 ~ CR10-1, CRH8-1 ~ CRH11
NPB3	4.76	7.5	6	10	5.5	1.5	CR12 ~ CR22, CRH12 ~ CRH22
NPB3-1	4.76	7.5	6	12.5	5.5	1.55	CR24 ~ CR36, CRH24 ~ CRH44
NPB4	6.35	8	6	13	6	2	CR48, CRH48 ~ CRH64

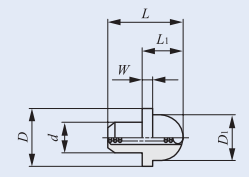
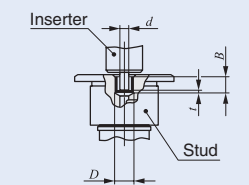


Table 16 Dimensions of plug for Inch series Cam Followers

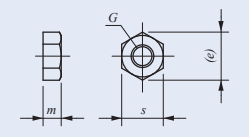
Identification number	Dimensions of plug mm			Dimension of inserter mm	Applicable bearings (1)
	D	t	B		
USB2F	3.18	0.3	3.3	2.3	CR 8 ~ CR10-1
USB3F	4.76	0.4	4.3	3.7	CR12~CR36, CRH12 ~ CRH44
USB4F	6.35	0.5	4.8	5.2	CR48, CRH48~CRH64



Note(1) Shows representative types.

Table 17 Metric series nut dimensions(1)

Model of bearing	Stud diameter d ₁ (2) mm	Nut dimensions mm			
		G	m	s	e
CF CFKR CFES CFE CFKRE CF...W CF-RU1 CF-FU1 CF...G CF...WB.../SG CFS CFS...W NUCF...B	1.4	M 1.4x0.3	1.1	3	3.25
	2	M 2 x0.4	1.6	4	4.6
	2.5	M 2.5x0.45	2	5	5.8
	3	M 3 x0.5	2.4	5.5	6.4
	4	M 4 x0.7	3.2	7	8.1
	5	M 5 x0.8	4	8	9.2
	6	M 6 x1	5	10	11.5
	8	M 8 x1.25	6.5	13	15
	10	M10 x1.0(3) M10 x1.25	8	17	19.6
	12	M12 x1.5	10	19	21.9
	16	M16 x1.5	13	24	27.7
	18	M18 x1.5	15	27	31.2
20	M20 x1.5	16	30	34.6	
24	M24 x1.5	19	36	41.6	
30	M30 x1.5	24	46	53.1	



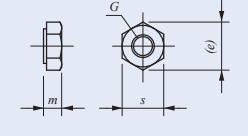
Note(1) See pages I57~I58 for dimensions of the dedicated flange nut included with the Short Stud Cam Follower CFC...B.

(2) For Eccentric Type Cam Followers, thread diameter G as shown in the dimension table is applicable.

(3) Applicable to Standard Type Cam Follower CFKR, and Eccentric Type Cam Follower CFKRE.

Table 18 Inch series nut dimensions

Model of bearing	Stud diameter d ₁ (inch)	Nut dimensions mm			
		G UNF	m	s	e
CR CRH	4.826	No.10-32	4	8	9.2
	6.35 (1/4)	1/4-28	5.5	10	11.5
	7.938 (5/16)	5/16-24	6.5	12	13.8
	9.525 (3/8)	3/8-24	8	14	16.2
	11.112 (7/16)	7/16-20	10	17	19.5
	12.7 (1/2)	1/2-20	11	19	21.9
	15.875 (5/8)	5/8-18	14	23	26.5
	19.05 (3/4)	3/4-16	16	26	30
	22.225 (7/8)	7/8-14	19	32	37
	25.4 (1)	1 -14UNS	22	36	41.4
	28.575 (1 1/8)	1 1/8-12	24	41	47.1
	31.75 (1 1/4)	1 1/4-12	27	46	53.5
	38.1 (1 1/2)	1 1/2-12	33	55	63.5
	44.45 (1 3/4)	1 3/4-12UN	38	65	75.1
	50.8 (2)	2 -12UN	44	75	86.6

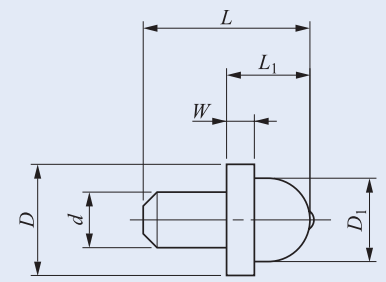


Special Specification

The grease nipple supplied with Metric series Cam Follower with hexagon socket as an accessory may be replaced with the NPT type grease nipple indicated in Table 19 upon your request. If required, please order with supplemental code, "/NP" at the end of identification number.

Example of Identification Number
CF 12 BUU / NP

Table 19 Dimension of NPT type grease nipple

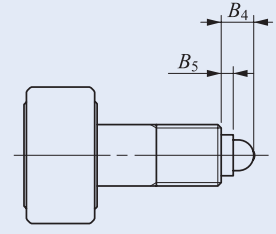


Code number	Dimension of grease nipple mm						Size of stud dia. d ₁ (1) mm
	d	D	D ₁	L	L ₁	W	
NPT4-1	4	8	6	12	6	2	12 ~ 16
NPT6-1	6	8	6	14	8	4	18 ~ 30

Note(1) For Eccentric Type Cam Follower CFE, thread diameter G is applied.

Remark Not applicable to Standard Type Cam Follower CFKR, and Eccentric Type Cam Follower CFKRE.

Table 20 Dimension of assembled NPT type grease nipple



Code number	Dimension mm		Size of stud dia. d ₁ (1) mm
	B ₄	B ₅	
NPT4-1	6	2	12 ~ 16
NPT6-1	8	4	18 ~ 30

Note(1) For Eccentric Type Cam Follower CFE, thread diameter G is applied.

Mounting

① Make the center axis of the mounting hole perpendicular to the moving direction of the Cam Follower and match the side shoulder accurately with the seating surface indicated by dimension *f* in the table of dimensions. (See Fig. 1)

The chamfered mounting hole should be as small as possible (C0.5 or so).

When mounting Cam Followers, do not hit the flange head of the Cam Follower directly with a hammer, etc. This may lead to a bearing failure such as irregular rotation or cracking.

If the Cam Follower outer ring is not in good contact with the mating running surface then we recommend use of a crowned outer ring type.

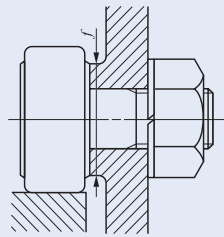


Fig. 1 Seating surface

② The **IKO** mark on the flange head of the stud indicates the position of the oil hole on the raceway. Avoid locating the oil hole within the loading zone. This may lead to a short bearing life. (See Fig. 2.) The hole located in the middle part of the stud perpendicular to the stud center axis is used for greasing or locking.

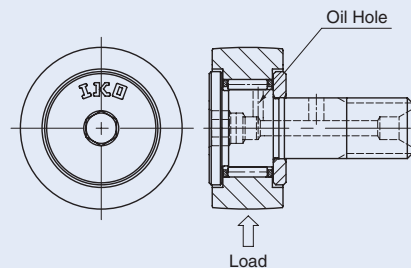


Fig. 2 Oil hole position and loading direction

③ When mounting Cam Followers, fix in place by holding the hexagon hole or screwdriver slot with a hex wrench or slotted screwdriver and use a wrench to tighten on a nut. (See Fig. 3.1)

If mounting by turning the hexagon hole or screwdriver slot itself, the hexagon hole or screwdriver slot of the Cam Follower may become damaged.

When mounting Short Stud Cam Followers, fix the dedicated flange nut as a rotation stopper with a wrench or hex wrench, and then tighten the hexagon socket head bolt by rotating with a hex wrench. (See Fig. 3.2 and Fig. 3.3)

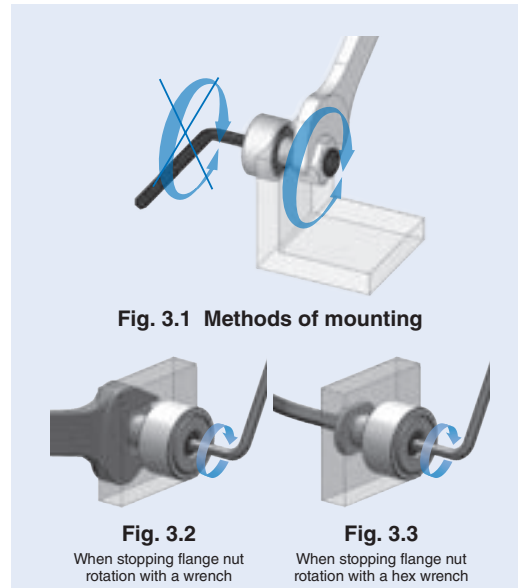


Fig. 3.1 Methods of mounting

Fig. 3.2
When stopping flange nut rotation with a wrench

Fig. 3.3
When stopping flange nut rotation with a hex wrench

④ When tightening the nut, the tightening torque should not exceed the values shown in the table of dimensions. If the tightening torque is too large, it is possible that the threaded portion of the stud will be broken. When there is a possibility of loosening, a special nut such as a lock nut, spring washer, or self-locking nut should be used.

⑤ When direct-fixing the Cam Follower without nuts for mounting as shown in Fig. 4, it may be difficult to achieve sufficient tightening torque. If the screw then loosens, stress may concentrate on the thread, causing the stud to break. Such a method is not recommended.

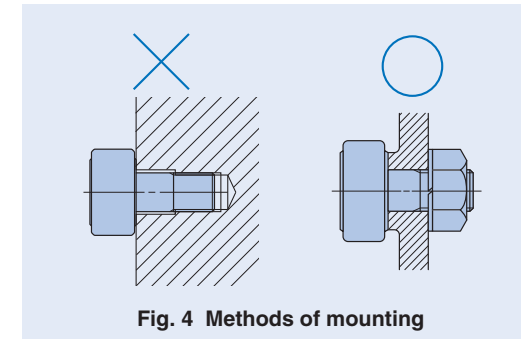


Fig. 4 Methods of mounting

⑥ Solid Eccentric Stud Type Cam Followers and Eccentric Type Cam Followers, are mounted in reference position where **IKO** mark on the head of stud is located as Fig.5. The outer ring position can be adjusted appropriately by turning the stud with a screwdriver or hexagon bar wrench using the screwdriver slot or hexagon hole of the stud head. The stud is fixed with a nut and a spring washer, etc. The tightening torque should not exceed the values of maximum tightening torque shown in the table of dimensions.

When shock loads are applied and the adjusted eccentricity has to be ensured, it is recommended to make holes in the housing, stud and eccentric collar, and fix the stud with a dowel pin as shown in Fig. 6. However, when the stud diameter is less than 8 mm (Eccentric collar diameter 11 mm), it is difficult to make a hole in the stud because the stud is through-hardened.

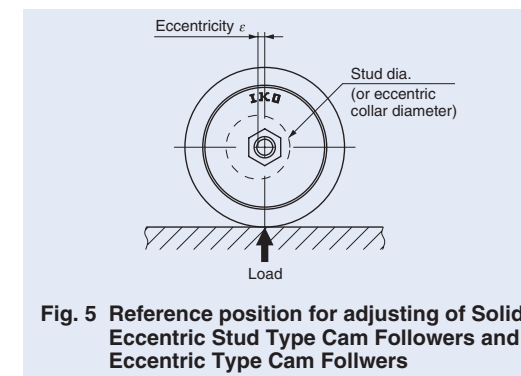


Fig. 5 Reference position for adjusting of Solid Eccentric Stud Type Cam Followers and Eccentric Type Cam Followers

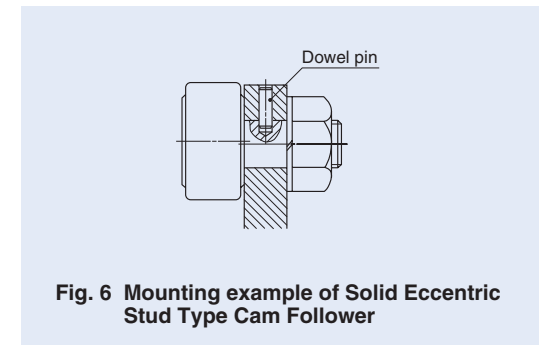


Fig. 6 Mounting example of Solid Eccentric Stud Type Cam Follower

⑦ For Short Stud Cam Followers, the cam follower mounting member material thickness range (T dimension in the dimension table on pages I57 ~ I58) is determined by the hexagon socket head bolt length. When the designed mounting member material exceeds the tolerance range of the bolt supplied, the customer should use a hexagon socket head bolt (strength division 12.9). When considering mounting member material with thickness outside the range in Fig. 7, please contact IKO.

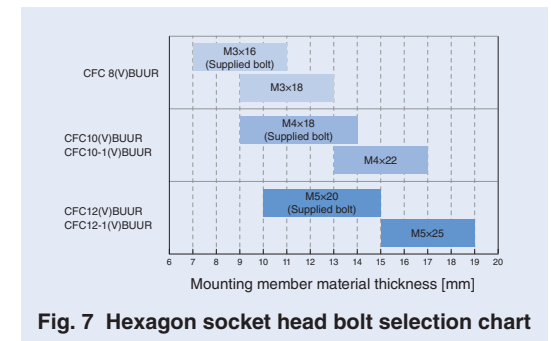


Fig. 7 Hexagon socket head bolt selection chart

CF
CFKR
CFS
NUCF
CR

⑧ The length of a mounting hole for Eccentric Type Cam Followers must be at least that of the S dimension in Fig. 8.

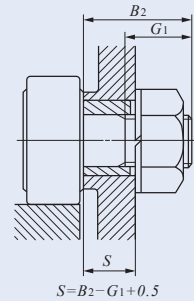


Fig. 8 Length of the mounting hole of Eccentric Type Cam Follower

⑨ Eccentric collar is available for Inch series Cam Followers. Cam Followers with Eccentric collars, CRE are also available. If required, please consult with IKO.

Table 20 Eccentric collars for Inch series Cam Followers

Identical number of collar	Outer diameter of collar d_ϵ	Length of collar B_3	Eccentricity ϵ	Stud dia. d	Applicable Cam Followers
EB 8	6.350 (1/4)	9.525 (3/8)	0.250	4.826	CR 8 CR 8-1 (V)(B)(UU)(R)
EB10	9.525 (3/8)	11.100	0.380	6.350 (1/4)	CR10 CR10-1 (V)(B)(UU)(R)
EB12	12.700 (1/2)	12.700 (1/2)	0.380	9.525 (3/8)	CR12 CR14 (V)(B)(UU)(R)
EB16	15.875 (5/8)	12.700 (1/2)	0.760	11.112 (7/16)	CR16 CR18 (V)(B)(UU)(R)
EB20	17.450	15.875 (5/8)	0.760	12.700 (1/2)	CR20 CR22 (V)(B)(UU)(R)
EB24	22.225 (7/8)	19.050 (3/4)	0.760	15.875 (5/8)	CR24 CR26 (V)(B)(UU)(R)
EB28	25.400 (1)	22.225 (7/8)	0.760	19.050 (3/4)	CR28 CR30 (V)(B)(UU)(R)
EB32	30.150	25.400 (1)	0.760	22.225 (7/8)	CR32 CR36 (V)(B)(UU)(R)
EB48	44.450 (1 3/4)	31.750 (1 1/4)	1.520	31.750 (1 1/4)	CR48 VUU

unit: mm

⑩ For mounting Easy Mounting Type Cam Followers, it is recommended to fix the fixing screw from the upper side to the stepped portion of the stud. (See Fig. 9.) While M5 - M6 screws are generally used as fixing screws, adjust the size used depending on the usage criteria.

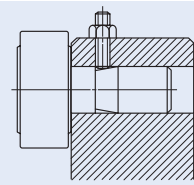


Fig. 9 Mounting example of Easy Mounting Type Cam Follower

Operating Temperature Range

Operating temperature range of Cam Followers is -20°C ~ +120°C. However, note that the maximum allowable temperature varies in models shown in Table 21.

Table 21 Limitation of operating temperature range

Model Stud diameter d_1 mm	Item	With cage		Full complement ThrustDisk Seals™
		Shield type	Sealed type	
Miniature Type Cam Followers CFS Thrust Disk Type Miniature Cam Followers CFS ... W	$d_1 = 2$	-20°C ~ 110°C ⁽¹⁾	-	-
		-20°C ~ 110°C ⁽¹⁾	-	-
Standard Type Cam Followers CF ... B Thrust Disk Type Cam Followers CF ... WB	$d_1 = 3, 4$ $d_1 = 5$	-20°C ~ 110°C ⁽¹⁾	-20°C ~ 80°C	-
		-20°C ~ 120°C	-	-
Standard Type Cam Followers / Stainless Steel Made CF ... FB Thrust Disk Type Cam Followers / Stainless Steel Made CF ... FWB	$3 \leq d_1 \leq 5$	-20°C ~ 110°C ⁽¹⁾	-20°C ~ 80°C	-
		-20°C ~ 110°C ⁽¹⁾	-20°C ~ 80°C	-
C-Lube Cam Followers CF ... WB ... /SG	$5 \leq d_1 \leq 20$	-	-15°C ~ 80°C ⁽²⁾	-
Inch Series Cam Followers ThrustDisk Seals™ CR ... VBS	$4.826 \leq d_1 \leq 22.225$	-	-	-20°C ~ 80°C

Notes⁽¹⁾ 100°C when used continuously.
⁽²⁾ Below 60°C is recommended for long use.

Precaution For Use

① Do not wash C-Lube Cam Followers with organic solvent and/or white kerosene or leave them in contact with these agents because they have the ability to remove grease.

② To ensure normal rotation of the C-Lube Cam Follower, apply a load of 1% or more of the dynamic load rating at use.

Option Parts

C-Lube Unit for Cam Followers

Structure and features

IKO C-Lube unit for Cam Follower is a lubrication part to be mounted on the Cam Follower and its integral capillary lubricating element has a lot of lubrication oil impregnated in it.

The capillary lubricating element is consecutive porous resin formed by sinter molding of fine resin powder and a lot of lubrication oil is impregnated in it by using the capillary action that occurs within the internal space.

Regular lubrication is not needed as lubrication oil is supplied onto the outside diameter surface of the outer ring and mating guide surface (cam guide surface). The grease is not scattered and contamination of the surrounding environment is prevented.

The combination with IKO C-Lube cam follower (See Page I55) realizes maintenance-free cam follower inside and cam guide surface.

Structure of C-Lube Unit for Cam Followers

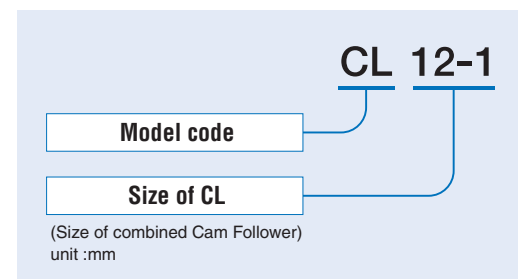
Magnified photos of C-Lube

Before impregnating oil: Resin particles are strongly fusion bonded.

After impregnating oil: Lubricant is retained in cavities amongst resin particles.

Identification number

The identification number example of IKO C-Lube Unit is shown below.



Allowable Rotational speed

The Rotational speed of IKO Cam Follower with C-Lube Unit should not exceeded $d_1 n = 10,000$ for reference.

$$d_1 n = d_1 \times n$$

d_1 : Stud diameter of Cam Follower, mm
 n : Rotational speed, min⁻¹

Minimum rotational angle

Lubricating oil is supplied to the whole external diameter surface of the outer ring. Accordingly, use the product in a condition in which the outer ring makes one or more turns.

Operating temperature

Allowable operating temperature range of IKO Cam Follower with C-Lube Unit is -15 to 80°C.

Mounting

- 1 Set the C-Lube Unit perpendicularly to the center axis of Cam Follower and fix together with Cam Follower by tightening nut. (See Fig. 10.)

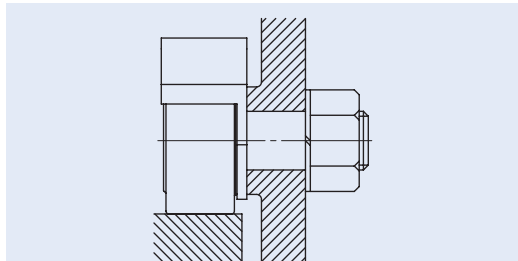


Fig. 10 Mounting of C-Lube Unit

- 2 Position of C-Lube Unit is adjustable. C-Lube Unit must be positioned avoiding loading direction. (See Fig. 11.)

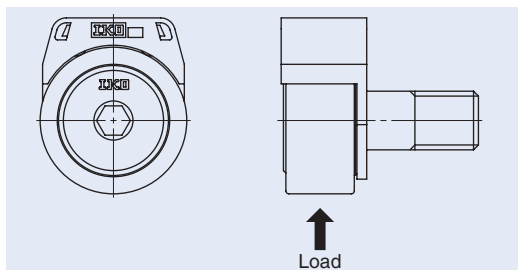


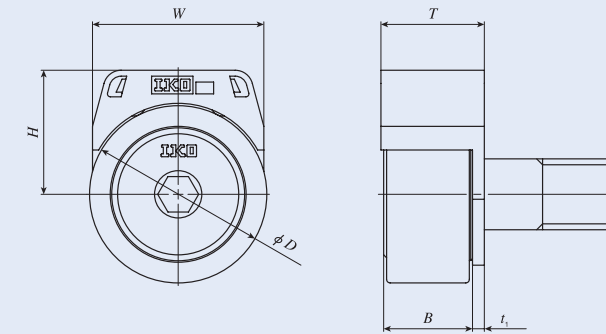
Fig. 11 Load direction of Cam Follower

- 3 When tightening the nut, the tightening torque should not be exceeded the value maximum tightening torque on dimension table. In case loosening of the nut is predicted due to vibration, using lock nut, spring washer and other special washer are recommended.

Precaution for use

- 1 Do not wash with organic solvent and/or white kerosene, which have the ability of removing fat nor leave them in contact with the above agents.
- 2 Do not apply a load onto the C-Lube Unit directly.
- 3 To ensure normal rotation of the Cam Follower, apply a load of 1% or over of the dynamic load rating at use. Also, the outer ring needs to be rotate over a revolution to supply lubricant on entire outer diameter surface.
- 4 The maximum allowable load on IKO Cam Follower with C-Lube Unit is, 80% of the maximum allowable load of the needle bearing. C-Lube Unit may be damaged and influenced to the smooth rotation and lubricating performance by excessive load.
- 5 After assembling C-Lube Unit and Cam Followers in the machine, please confirm that C-Lube unit provides oil correctly to the cam guide surface before actual operation.
- 6 Do not use in the environment which contamination of liquid and/or harmful foreign matter are expected.
- 7 Replace with new C-Lube Unit when inside oil finishes completely. Re-lubrication is not possible.

Table 21 Dimensions of C-Lube Unit for Cam Followers



Model number	Boundary Dimensions mm				Applicable Cam Followers		
	W	H	T	t ₁	Model number (1)	Boundary Dimensions mm	
						D	B
CL 5	12.4	10.7	12.1	1.5	CF 5 B	13	10
CL 6	15.4	12.6	14	1.5	CF 6 B	16	12.2 max
CL 8	18.4	14.2	14	1.5	CF 8 B	19	12.2 max
CL 10	21	17	15.5	2	CF 10 B CFKR 22	22	13.2 max
CL 10-1	21	19.2	15.5	2	CF 10-1 B CFKR 26	26	13.2 max
CL 12	29	21	17.5	2	CF 12 B CFKR 30	30	15.2 max
CL 12-1	29	22	17.5	2	CF 12-1 B CFKR 32	32	15.2 max
CL 16	33.8	27.4	23.4	2.5	CF 16 B CFKR 35	35	19.6 max
CL 18	38.8	30.4	25.4	2.5	CF 18 B CFKR 40	40	21.6 max
CL 20	45.8	38.4	29.9	3	CF 20 B CFKR 52	52	25.6 max
CL 20-1	45.8	35.4	29.9	3	CF 20-1 B CFKR 47	47	25.6 max

Note(1) Only representative identification numbers are shown in the table, but applicable to all Cam Followers other than Miniature Type Cam Followers and Inch Series Cam Followers.

It is recommended to use together with C-Lube Cam Followers in order to make maintenance-free more effective.

Remark Load on the Cam Follower with the C-Lube unit equipped must be up to 80% of the maximum allowable static load of the Cam Follower to be combined. For the maximum allowed static load of each Cam Follower, please see the dimension tables of respective models.

I
CF
CFKR
CFS
NUCF
CR

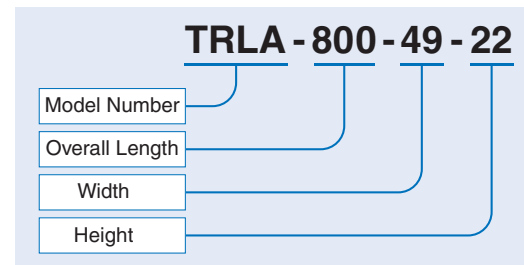
Option Parts

Way for Cam Follower

The accuracy of the mating cam guide that comes in contact with the outer ring of Cam Followers has a large influence on the guide performance of Cam Followers and machinery.

A specially designed high-precision Way for Cam Follower should be used in order to achieve sufficient performance from the Cam Followers. Fixed with bolts for simple assembly and available in 2 models - A type or B type - depending on the mounting direction.

Identification number



Model Types

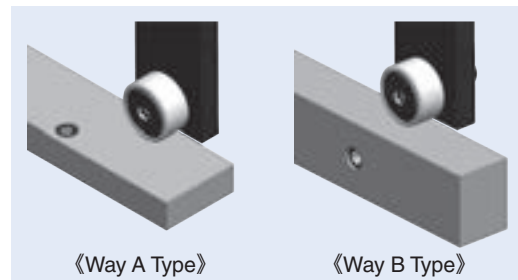
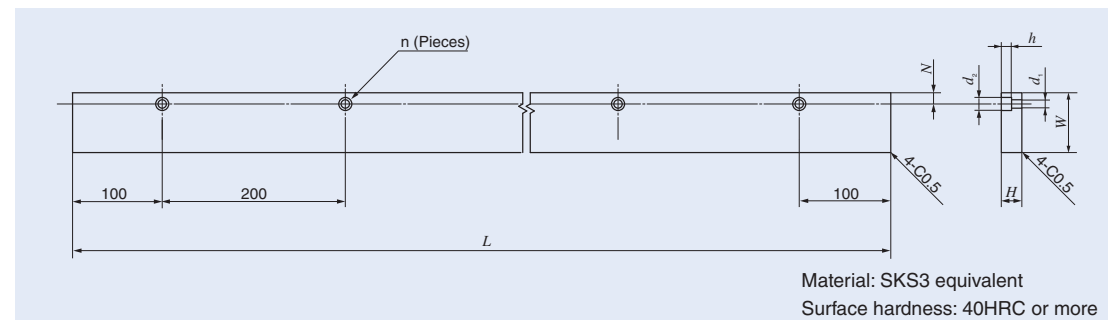


Table of Dimensions

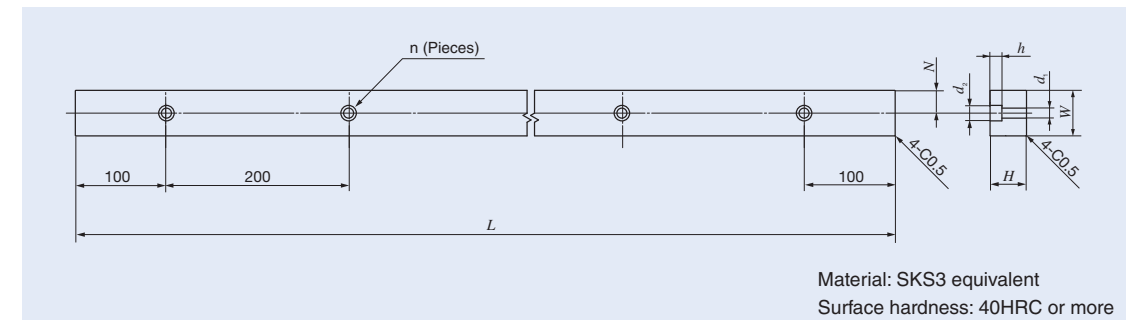
《Way A Type》



Identification number	Boundary Dimensions mm							Applicable Cam Followers
	$L(n)$	W	H	N	d_1	d_2	h	
TRLA- 600-40-22	600(3)	40						Stud dia. 3~ 8mm
TRLA- 800-40-22	800(4)							
TRLA-1000-40-22	1000(5)							
TRLA- 600-49-22	600(3)	49	22	12	9	14	11	Stud dia.10~18mm
TRLA- 800-49-22	800(4)							
TRLA-1000-49-22	1000(5)							
TRLA- 600-64-22	600(3)	64						Stud dia.20~30mm
TRLA- 800-64-22	800(4)							
TRLA-1000-64-22	1000(5)							

Remark For other dimensions, please contact IKO.

《Way B Type》



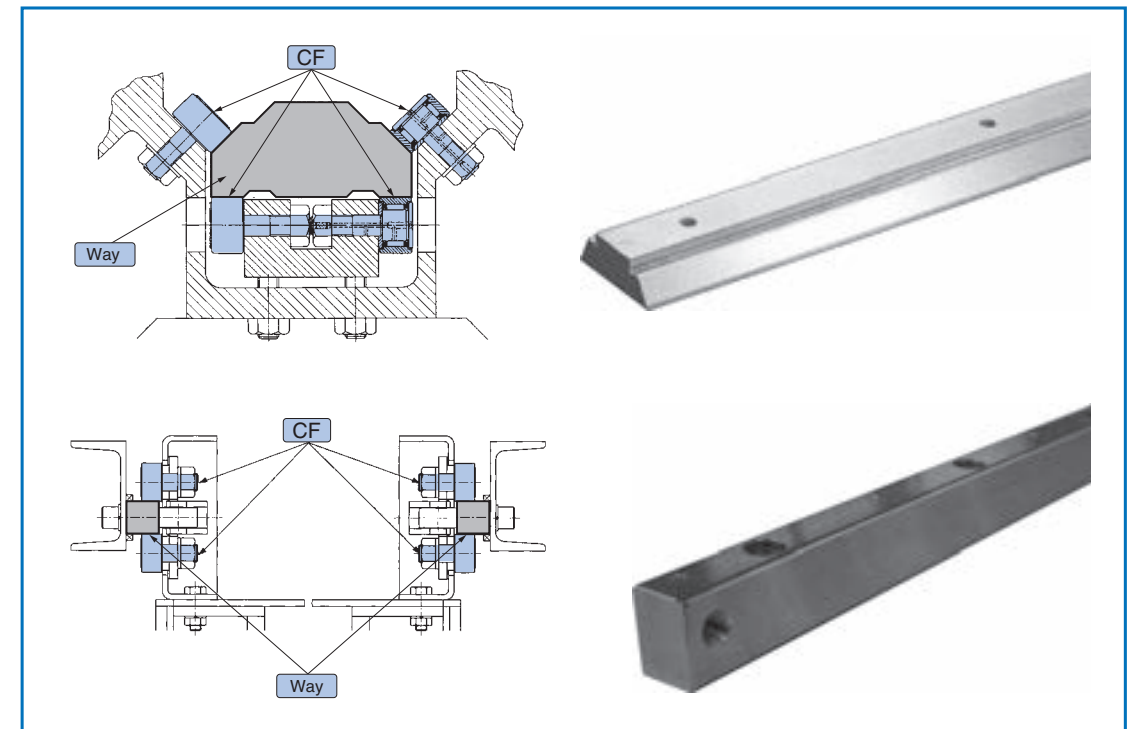
Identification number	Boundary Dimensions mm							Applicable Cam Followers
	$L(n)$	W	H	N	d_1	d_2	h	
TRLB- 600-34-22	600(3)	34	22	17	9	14	11	Stud dia. 3~12mm
TRLB- 800-34-22	800(4)							
TRLB-1000-34-22	1000(5)							
TRLB- 600-50-40	600(3)	50	40	25	11	17	13	Stud dia.16~30mm
TRLB- 800-50-40	800(4)							
TRLB-1000-50-40	1000(5)							

Remark For other dimensions, please contact IKO.

Introduction of Special Support Examples

Introducing special support examples for Ways for Cam Follower.

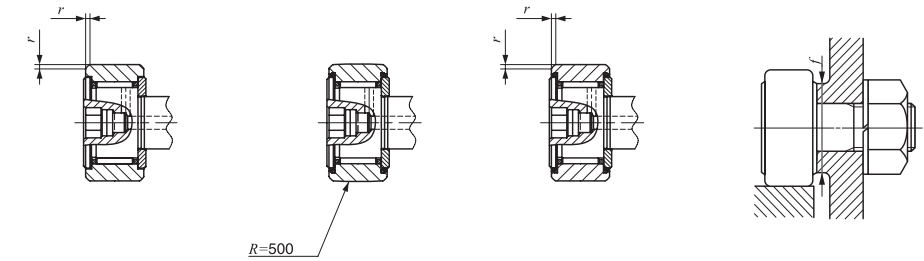
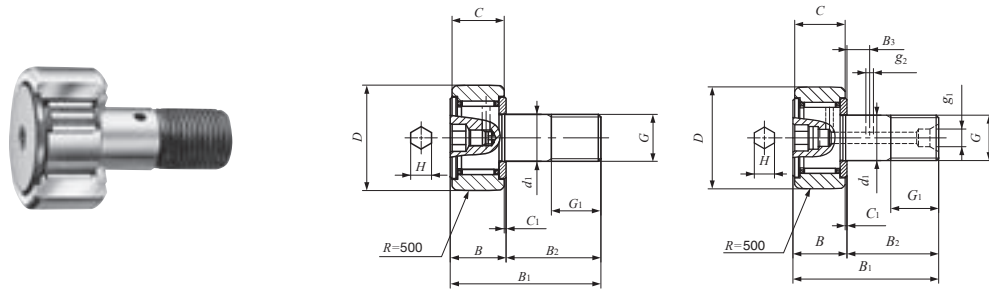
A variety of shapes are supported in addition to the special support examples. For details, please contact IKO.



I
CF
CFKR
CFS
NUCF
CR

CAM FOLLOWERS

Standard Type Cam Followers CF...B With Cage/Stud Head Hex Hole



Stud dia. 3—30mm

CF...BR
Stud dia d_1 3-10mm

CF...BR
Stud dia d_1 12-30mm

Stud dia. mm	Identification number				Mass (Ref.) $g^{(2)}$				
	Shield type		Sealed type			D	C	d_1	G
	With crowned outer ring	With cylindrical outer ring	With crowned outer ring	With cylindrical outer ring					
3	CF 3 BR	CF 3 B	CF 3 BUUR	CF 3 BUU	4.3	10	7	3	M 3×0.5
	CF 3 BR	CF 3 B	CF 3 BUUR	CF 3 BUU					
4	CF 4 BR	CF 4 B	CF 4 BUUR	CF 4 BUU	7.4	12	8	4	M 4×0.7
	CF 4 BR	CF 4 B	CF 4 BUUR	CF 4 BUU					
5	CF 5 BR	CF 5 B	CF 5 BUUR	CF 5 BUU	10.3	13	9	5	M 5×0.8
	CF 5 BR	CF 5 B	CF 5 BUUR	CF 5 BUU					
6	CF 6 BR	CF 6 B	CF 6 BUUR	CF 6 BUU	18.5	16	11	6	M 6×1
	CF 6 BR	CF 6 B	CF 6 BUUR	CF 6 BUU					
8	CF 8 BR	CF 8 B	CF 8 BUUR	CF 8 BUU	28.5	19	11	8	M 8×1.25
	CF 8 BRM	CF 8 BM	CF 8 BUURM	CF 8 BUUM					
	CF 8 BR	CF 8 B	CF 8 BUUR	CF 8 BUU					
10	CF 10 BR	CF 10 B	CF 10 BUUR	CF 10 BUU	45	22	12	10	M10×1.25
	CF 10 BRM	CF 10 BM	CF 10 BUURM	CF 10 BUUM					
	CF 10-1 BR	CF 10-1 B	CF 10-1 BUUR	CF 10-1 BUU					
	CF 10-1 BRM	CF 10-1 BM	CF 10-1 BUURM	CF 10-1 BUUM					
	CF 10-1 BR	CF 10-1 B	CF 10-1 BUUR	CF 10-1 BUU					
12	CF 12 BR	CF 12 B	CF 12 BUUR	CF 12 BUU	95	30	14	12	M12×1.5
	CF 12-1 BR	CF 12-1 B	CF 12-1 BUUR	CF 12-1 BUU					
16	CF 16 BR	CF 16 B	CF 16 BUUR	CF 16 BUU	170	35	18	16	M16×1.5
	CF 16 BR	CF 16 B	CF 16 BUUR	CF 16 BUU					
18	CF 18 BR	CF 18 B	CF 18 BUUR	CF 18 BUU	250	40	20	18	M18×1.5
	CF 18 BR	CF 18 B	CF 18 BUUR	CF 18 BUU					
20	CF 20 BR	CF 20 B	CF 20 BUUR	CF 20 BUU	460	52	24	20	M20×1.5
	CF 20-1 BR	CF 20-1 B	CF 20-1 BUUR	CF 20-1 BUU					
24	CF 24 BR	CF 24 B	CF 24 BUUR	CF 24 BUU	815	62	29	24	M24×1.5
	CF 24-1 BR	CF 24-1 B	CF 24-1 BUUR	CF 24-1 BUU					
30	CF 30 BR	CF 30 B	CF 30 BUUR	CF 30 BUU	1 870	80	35	30	M30×1.5
	CF 30-1 BR	CF 30-1 B	CF 30-1 BUUR	CF 30-1 BUU					
	CF 30-2 BR	CF 30-2 B	CF 30-2 BUUR	CF 30-2 BUU					

Note⁽¹⁾ For dimensions other than the chamfer dimension (r) and the shape of the outside surface of the outer ring outside surface, refer to the CF...BR drawing.

⁽²⁾ This is the value for the product body only. The values for the accessories shown in Table 13 on page I14 are not included.

⁽³⁾ Minimum allowable value of chamfer dimension r

Remarks 1. Models with a stud diameter d_1 of 4 mm or less have no oil hole. For models with a stud dia. 5 to 10mm, oil hole (re-greasing fitting) is provided at the head. Other models are provided with an oil hole (grease nipple) at the head and an oil hole each on the outside surface and end surface of the stud.

2. Shield type models with a stud diameter d_1 of 10mm or less and the sealed type models are provided with prepacked grease. Other models are not provided with prepacked grease. Perform proper lubrication for use.

CF...B(1)

CF...BUUR(1)

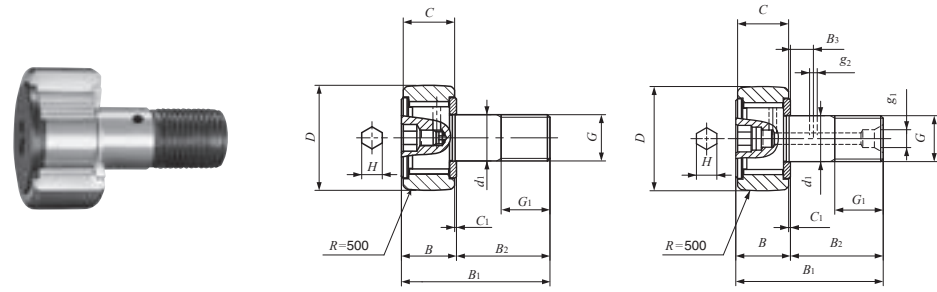
CF...BUU(1)

Boundary dimensions mm										Mounting dimension f Min. mm	Maximum tightening torque N·m	Basic dynamic load rating C N	Basic static load rating C_0 N	Maximum allowable static load N
G_1	B	B_1	B_2	B_3	C_1	g_1	g_2	H	$r_{s \text{ min}}^{(3)}$					
5	8	17	9	—	0.5	—	—	2	0.2	6.8	0.34	1 500	1 020	384
6	9	20	11	—	0.5	—	—	2.5	0.3	8.3	0.78	2 070	1 590	834
7.5	10	23	13	—	0.5	—	—	3	0.3	9.3	1.6	2 520	2 140	1 260
8	12.2max	28.2max	16	—	0.6	—	—	3	0.3	11	2.7	3 660	3 650	1 950
10	12.2max	32.2max	20	—	0.6	—	—	4	0.3	13	6.5	4 250	4 740	4 620
10	12.2max	32.2max	20	—	0.6	—	—	4	0.3	13	7.1	4 250	4 740	4 620
12	13.2max	36.2max	23	—	0.6	—	—	4	0.3	16	13.8	5 430	6 890	6 890
12	13.2max	36.2max	23	—	0.6	—	—	4	0.3	16	14.7	5 430	6 890	6 890
12	13.2max	36.2max	23	—	0.6	—	—	4	0.3	16	13.8	5 430	6 890	6 890
12	13.2max	36.2max	23	—	0.6	—	—	4	0.3	16	14.7	5 430	6 890	6 890
13	15.2max	40.2max	25	6	0.6	4	3	6	0.6	21	21.9	7 910	9 790	9 790
13	15.2max	40.2max	25	6	0.6	4	3	6	0.6	21	21.9	7 910	9 790	9 790
17	19.6max	52.1max	32.5	8	0.8	4	3	6	0.6	26	58.5	12 000	18 300	18 300
19	21.6max	58.1max	36.5	8	0.8	6	3	8	1	29	86.2	14 800	25 200	25 200
21	25.6max	66.1max	40.5	9	0.8	6	4	8	1	34	119	20 700	34 600	34 600
21	25.6max	66.1max	40.5	9	0.8	6	4	8	1	34	119	20 700	34 600	34 600
25	30.6max	80.1max	49.5	11	0.8	6	4	12	1	40	215	30 500	52 600	52 000
25	30.6max	80.1max	49.5	11	0.8	6	4	12	1	40	215	30 500	52 600	52 000
32	37 max	100 max	63	15	1	6	4	17	1	49	438	45 400	85 100	85 100
32	37 max	100 max	63	15	1	6	4	17	1	49	438	45 400	85 100	85 100
32	37 max	100 max	63	15	1	6	4	17	1	49	438	45 400	85 100	85 100

I
CF
CFKR
CFS
NUCF
CR

CAM FOLLOWERS

Standard Type Cam Followers CF...B Full Complement Type/Stud Head Hex Hole



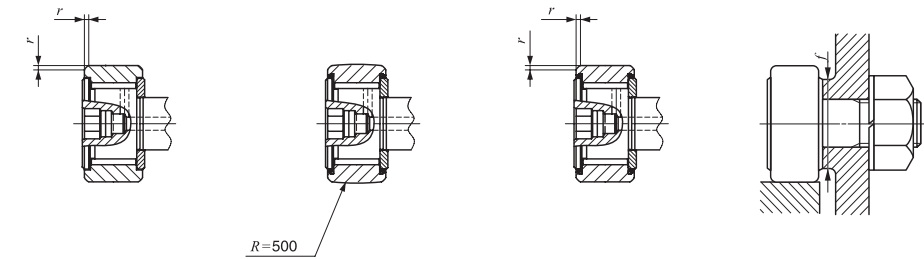
Stud dia. 6–30mm

CF...VBR
Stud dia. d_1 6-10mm

CF...VBR
Stud dia. d_1 12-30mm

Stud dia. mm	Identification number				Mass (Ref.) $g^{(2)}$	D	C	d_1
	Shield type		Sealed type					
	With crowned outer ring	With cylindrical outer ring	With crowned outer ring	With cylindrical outer ring				
6	CF 6 VBR	CF 6 VB	CF 6 VBUUR	CF 6 VBUU	19	16	11	6
	CF 6 VBRM	CF 6 VBM	CF 6 VBUURM	CF 6 VBUUM				
8	CF 8 VBR	CF 8 VB	CF 8 VBUUR	CF 8 VBUU	29	19	11	8
	CF 8 VBRM	CF 8 VBM	CF 8 VBUURM	CF 8 VBUUM	29	19	11	8
10	CF 10 VBR	CF 10 VB	CF 10 VBUUR	CF 10 VBUU	46	22	12	10
	CF 10 VBRM	CF 10 VBM	CF 10 VBUURM	CF 10 VBUUM	46	22	12	10
	CF 10-1 VBR	CF 10-1 VB	CF 10-1 VBUUR	CF 10-1 VBUU	61	26	12	10
	CF 10-1 VBRM	CF 10-1 VBM	CF 10-1 VBUURM	CF 10-1 VBUUM	61	26	12	10
	CF 10-1 VBR	CF 10-1 VB	CF 10-1 VBUUR	CF 10-1 VBUU	61	26	12	10
12	CF 12 VBR	CF 12 VB	CF 12 VBUUR	CF 12 VBUU	97	30	14	12
	CF 12-1 VBR	CF 12-1 VB	CF 12-1 VBUUR	CF 12-1 VBUU	107	32	14	12
16	CF 16 VBR	CF 16 VB	CF 16 VBUUR	CF 16 VBUU	173	35	18	16
18	CF 18 VBR	CF 18 VB	CF 18 VBUUR	CF 18 VBUU	255	40	20	18
20	CF 20 VBR	CF 20 VB	CF 20 VBUUR	CF 20 VBUU	465	52	24	20
	CF 20-1 VBR	CF 20-1 VB	CF 20-1 VBUUR	CF 20-1 VBUU	390	47	24	20
24	CF 24 VBR	CF 24 VB	CF 24 VBUUR	CF 24 VBUU	820	62	29	24
	CF 24-1 VBR	CF 24-1 VB	CF 24-1 VBUUR	CF 24-1 VBUU	1 140	72	29	24
30	CF 30 VBR	CF 30 VB	CF 30 VBUUR	CF 30 VBUU	1 870	80	35	30
	CF 30-1 VBR	CF 30-1 VB	CF 30-1 VBUUR	CF 30-1 VBUU	2 030	85	35	30
	CF 30-2 VBR	CF 30-2 VB	CF 30-2 VBUUR	CF 30-2 VBUU	2 220	90	35	30

Note⁽¹⁾ For dimensions other than the chamfer dimension (r) and the shape of the outside surface of the outer ring outside surface, refer to the CF...VBR drawing.
⁽²⁾ This is the value for the product body only. The values for the accessories shown in Table 13 on page I14 are not included.
⁽³⁾ Minimum allowable value of chamfer dimension r
 Remarks1. Models with a stud diameter d_1 of 10 mm or less have an oil hole (re-greasing fitting) at the head. Other models are provided with an oil hole (grease nipple) at the head and an oil hole each on the outside surface and end surface of the stud.
 2. Provided with prepacked grease.



CF...VB⁽¹⁾

CF...VBUUR⁽¹⁾

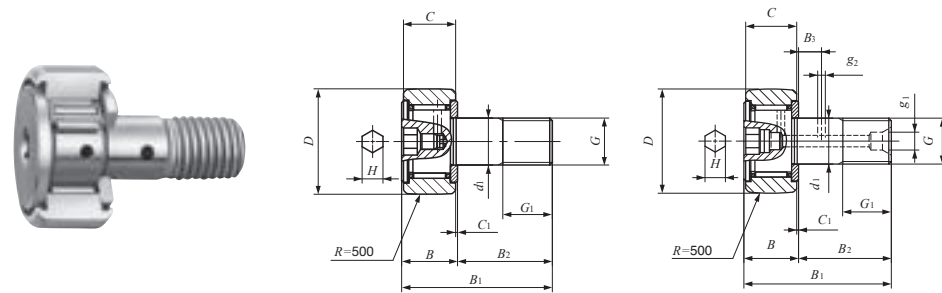
CF...VBUU⁽¹⁾

Boundary dimensions mm	Mounting dimension											Maximum tightening torque N-m	Basic dynamic load rating C N	Basic static load rating C ₀ N	Maximum allowable static load N
	G	G ₁	B _{max}	B _{1max}	B ₂	B ₃	C ₁	g ₁	g ₂	H	$r_{smin}^{(3)}$				
M 6×1	8	12.2	28.2	16	—	0.6	—	—	3	0.3	11	2.7	6 980	8 500	1 950
M 8×1.25	10	12.2	32.2	20	—	0.6	—	—	4	0.3	13	6.5	8 170	11 200	4 620
M 8×1	10	12.2	32.2	20	—	0.6	—	—	4	0.3	13	7.1	8 170	11 200	4 620
M10×1.25	12	13.2	36.2	23	—	0.6	—	—	4	0.3	16	13.8	9 570	14 500	8 650
M10×1	12	13.2	36.2	23	—	0.6	—	—	4	0.3	16	14.7	9 570	14 500	8 650
M10×1.25	12	13.2	36.2	23	—	0.6	—	—	4	0.3	16	13.8	9 570	14 500	8 650
M10×1	12	13.2	36.2	23	—	0.6	—	—	4	0.3	16	14.7	9 570	14 500	8 650
M12×1.5	13	15.2	40.2	25	6	0.6	4	3	6	0.6	21	21.9	13 500	19 700	13 200
M12×1.5	13	15.2	40.2	25	6	0.6	4	3	6	0.6	21	21.9	13 500	19 700	13 200
M16×1.5	17	19.6	52.1	32.5	8	0.8	4	3	6	0.6	26	58.5	20 700	37 600	23 200
M18×1.5	19	21.6	58.1	36.5	8	0.8	6	3	8	1	29	86.2	25 300	51 300	31 100
M20×1.5	21	25.6	66.1	40.5	9	0.8	6	4	8	1	34	119	33 200	64 500	37 500
M20×1.5	21	25.6	66.1	40.5	9	0.8	6	4	8	1	34	119	33 200	64 500	37 500
M24×1.5	25	30.6	80.1	49.5	11	0.8	6	4	12	1	40	215	46 600	92 000	52 000
M24×1.5	25	30.6	80.1	49.5	11	0.8	6	4	12	1	40	215	46 600	92 000	52 000
M30×1.5	32	37	100	63	15	1	6	4	17	1	49	438	67 700	144 000	85 900
M30×1.5	32	37	100	63	15	1	6	4	17	1	49	438	67 700	144 000	85 900
M30×1.5	32	37	100	63	15	1	6	4	17	1	49	438	67 700	144 000	85 900

I
CF
CFKR
CFS
NUCF
CR

CAM FOLLOWERS

Standard Type Cam Followers CF...B / Stainless Steel Made With Cage/Stud Head Hex Hole



Stud dia. 3–20mm

CF...FBR Stud dia. d_1 3-10mm

CF...FBR Stud dia. d_1 12-20mm

Stud dia. mm	Identification number				Mass (Ref.) g ⁽²⁾	D	C	d_1	G	G_1
	Shield type		Sealed type							
	With crowned outer ring	With cylindrical outer ring	With crowned outer ring	With cylindrical outer ring						
3	CF 3 FBR	CF 3 FB	CF 3 FBUUR	CF 3 FBUU	4.3	10	7	3	M 3×0.5	5
4	CF 4 FBR	CF 4 FB	CF 4 FBUUR	CF 4 FBUU	7.4	12	8	4	M 4×0.7	6
5	CF 5 FBR	CF 5 FB	CF 5 FBUUR	CF 5 FBUU	10.3	13	9	5	M 5×0.8	7.5
6	CF 6 FBR	CF 6 FB	CF 6 FBUUR	CF 6 FBUU	18.5	16	11	6	M 6×1	8
8	CF 8 FBR	CF 8 FB	CF 8 FBUUR	CF 8 FBUU	28.5	19	11	8	M 8×1.25	10
10	CF 10 FBR	CF 10 FB	CF 10 FBUUR	CF 10 FBUU	45	22	12	10	M10×1.25	12
	CF 10-1 FBR	CF 10-1 FB	CF 10-1 FBUUR	CF 10-1 FBUU	60	26				
12	CF 12 FBR	CF 12 FB	CF 12 FBUUR	CF 12 FBUU	95	30	14	12	M12×1.5	13
	CF 12-1 FBR	CF 12-1 FB	CF 12-1 FBUUR	CF 12-1 FBUU	105	32				
16	CF 16 FBR	CF 16 FB	CF 16 FBUUR	CF 16 FBUU	170	35	18	16	M16×1.5	17
18	CF 18 FBR	CF 18 FB	CF 18 FBUUR	CF 18 FBUU	250	40	20	18	M18×1.5	19
20	CF 20 FBR	CF 20 FB	CF 20 FBUUR	CF 20 FBUU	460	52	24	20	M20×1.5	21
	CF 20-1 FBR	CF 20-1 FB	CF 20-1 FBUUR	CF 20-1 FBUU	385	47				

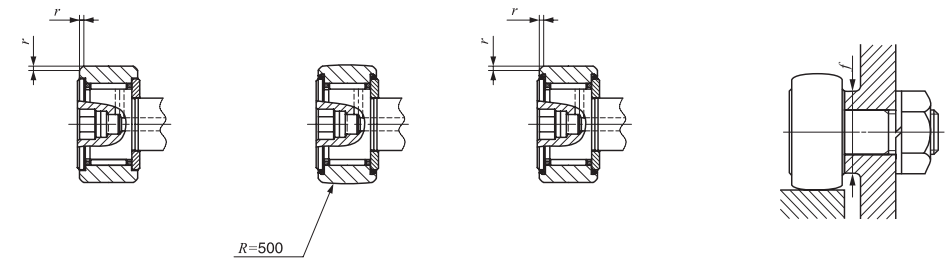
Note⁽¹⁾ For dimensions other than the chamfer dimension (r) and the shape of the outside surface of the outer ring outside surface, refer to the CF...FBR drawing.

⁽²⁾ This is the value for the product body only. The values for the accessories shown in Table 13 on page I14 are not included.

⁽³⁾ Minimum allowable value of chamfer dimension r

Remarks1. Models with a stud diameter d_1 of 4 mm or less have no oil hole. For models with a stud dia. 5 to 10 mm, oil hole (re-greasing fitting) is provided at the head. Other models are provided with an oil hole (grease nipple) at the head and an oil hole each on the outside surface and end surface of the stud.

2. Shield type models with a stud diameter d_1 of 10 mm or less and the sealed type models are provided with prepacked grease. Other models are not provided with prepacked grease. Perform proper lubrication for use.



CF...FB⁽¹⁾

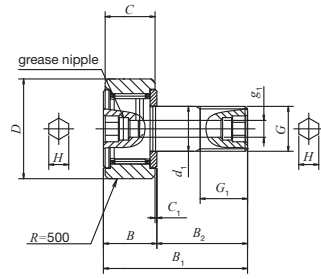
CF...FBUUR⁽¹⁾

CF...FBUU⁽¹⁾

Boundary dimensions mm										Mounting dimension f Min. mm	Maximum tightening torque N-m	Basic dynamic load rating C N	Basic static load rating C_0 N	Maximum allowable static load N
B	B_1	B_2	B_3	C_1	g_1	g_2	H	$r_{s \min}^{(3)}$						
8	17	9	—	0.5	—	—	2	0.2	6.8	0.34	1 200	813	384	
9	20	11	—	0.5	—	—	2.5	0.3	8.3	0.78	1 650	1 270	834	
10	23	13	—	0.5	—	—	3	0.3	9.3	1.6	1 930	1 730	1 260	
12.2 max	28.2 max	16	—	0.6	—	—	3	0.3	11	2.7	2 930	2 920	1 950	
12.2 max	32.2 max	20	—	0.6	—	—	4	0.3	13	6.5	3 400	3 790	3 790	
13.2 max	36.2 max	23	—	0.6	—	—	5	0.3	16	13.8	4 340	5 510	5 510	
15.2 max	40.2 max	25	6	0.6	4	3	6	0.6	21	21.9	6 330	7 830	7 830	
19.6 max	52.1 max	32.5	8	0.8	4	3	6	0.6	26	58.5	9 620	14 700	14 700	
21.6 max	58.1 max	36.5	8	0.8	6	3	8	1	29	86.2	11 800	20 200	20 200	
25.6 max	66.1 max	40.5	9	0.8	8	4	8	1	34	119	16 500	27 700	27 700	

I
CF
CFKR
CFS
NUCF
CR

Standard Type Cam Followers CFKR With Cage/Double Hex Hole

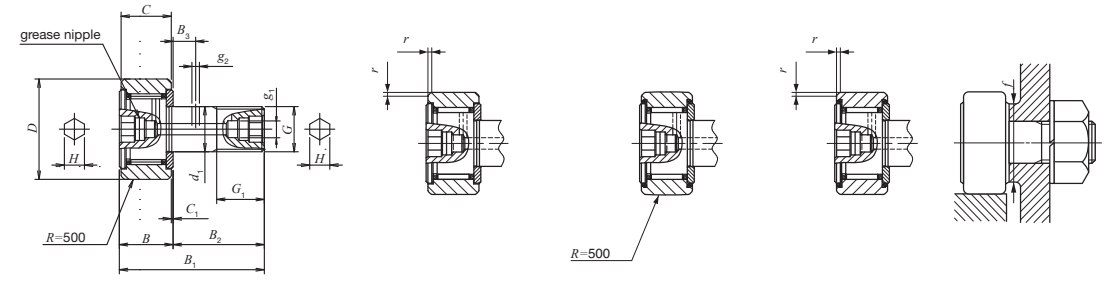


CFKR...R
Outside dia. of outer ring D 22, 26 mm

Stud dia. 10–30mm

Stud diameter mm	Identification number ⁽²⁾				Mass (Ref.) g ⁽³⁾					
	Shield type		Sealed type			D	C	d ₁	G	G ₁
	Crowned outer ring	Cylindrical outer ring	Crowned outer ring	Cylindrical outer ring						
10	CFKR 22 R	CFKR 22	CFKR 22 UUR	CFKR 22 UU	43	22	12	10	M10×1.0	12
	CFKR 26 R	CFKR 26	CFKR 26 UUR	CFKR 26 UU	58	26	12	10	M10×1.0	12
12	CFKR 30 R	CFKR 30	CFKR 30 UUR	CFKR 30 UU	94	30	14	12	M12×1.5	13
	CFKR 32 R	CFKR 32	CFKR 32 UUR	CFKR 32 UU	104	32	14	12	M12×1.5	13
16	CFKR 35 R	CFKR 35	CFKR 35 UUR	CFKR 35 UU	165	35	18	16	M16×1.5	17
18	CFKR 40 R	CFKR 40	CFKR 40 UUR	CFKR 40 UU	248	40	20	18	M18×1.5	19
20	CFKR 47 R	CFKR 47	CFKR 47 UUR	CFKR 47 UU	378	47	24	20	M20×1.5	21
	CFKR 52 R	CFKR 52	CFKR 52 UUR	CFKR 52 UU	453	52	24	20	M20×1.5	21
24	CFKR 62 R	CFKR 62	CFKR 62 UUR	CFKR 62 UU	795	62	29	24	M24×1.5	25
	CFKR 72 R	CFKR 72	CFKR 72 UUR	CFKR 72 UU	1 120	72	29	24	M24×1.5	25
30	CFKR 80 R	CFKR 80	CFKR 80 UUR	CFKR 80 UU	1 860	80	35	30	M30×1.5	32
	CFKR 85 R	CFKR 85	CFKR 85 UUR	CFKR 85 UU	2 020	85	35	30	M30×1.5	32
	CFKR 90 R	CFKR 90	CFKR 90 UUR	CFKR 90 UU	2 210	90	35	30	M30×1.5	32

Note⁽¹⁾ For dimensions other than the chamfer dimension (*r*) and the shape of the outside surface of the outer ring outside surface, refer to the CFKR...R drawing.
⁽²⁾ The identification number indicates the outer ring outside diameter.
⁽³⁾ This is the value for the product body only. The values for the accessories shown in Table 13 on page I14 are not included.
⁽⁴⁾ Minimum allowable value of chamfer dimension *r*.
 Remark Grease is pre-packed if the stud diameter *d*₁ of the shield type is 10 mm or less or if the seal structure is the sealed type. Other models are not provided with pre-packed grease. Perform proper lubrication for use.

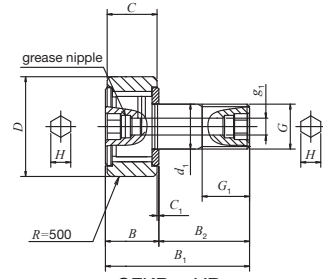


CFKR...R
Outside dia. of outer ring D 30 - 90 mm
 CFKR⁽¹⁾ CFKR...UUR⁽¹⁾ CFKR...UU⁽¹⁾

Boundary dimensions mm										Mounting dimension <i>f</i> Min. mm	Maximum tightening torque N·m	Basic dynamic load rating C N	Basic static load rating C ₀ N	Maximum allowable static load N
<i>B</i> _{max}	<i>B</i> _{1 max}	<i>B</i> ₂	<i>B</i> ₃	<i>C</i> ₁	<i>g</i> ₁	<i>g</i> ₂	<i>H</i>	<i>r</i> _{s min} ⁽⁴⁾						
13.2	36.2	23	—	0.6	3	—	5	0.3	16	13.0	5 430	6 890	6 890	
15.2	40.2	25	6	0.6	4	3	6	0.6	21	21.9	7 910	9 790	9 790	
19.6	52.1	32.5	8	0.8	4	3	8	0.6	26	58.5	12 000	18 300	18 300	
21.6	58.1	36.5	8	0.8	6	3	8	1	29	86.2	14 800	25 200	25 200	
25.6	66.1	40.5	9	0.8	6	4	10	1	34	119	20 700	34 600	34 600	
30.6	80.1	49.5	11	0.8	6	4	14	1	40	215	30 500	52 600	52 000	
37	100	63	15	1	6	4	14	1	49	438	45 400	85 100	85 100	

I
CF
CFKR
CFS
NUCF
CR

Standard Type Cam Followers CFKR Full Complement Type/Stud Head Hex Hole



CFKR...VR
Outside dia. of outer ring D 22, 26 mm

Stud dia. 10 – 30mm

Stud diameter mm	Identification number ⁽²⁾				Mass (Ref.) g ⁽³⁾					
	Shield type		Sealed type			D	C	d ₁	G	G ₁
	Crowned outer ring	Cylindrical outer ring	Crowned outer ring	Cylindrical outer ring						
10	CFKR 22 VR	CFKR 22 V	CFKR 22 VUUR	CFKR 22 VUU	44	22	12	10	M10×1.0	12
	CFKR 26 VR	CFKR 26 V	CFKR 26 VUUR	CFKR 26 VUU	59	26	14	12	M12×1.5	13
12	CFKR 30 VR	CFKR 30 V	CFKR 30 VUUR	CFKR 30 VUU	96	30	14	12	M12×1.5	13
	CFKR 32 VR	CFKR 32 V	CFKR 32 VUUR	CFKR 32 VUU	106	32	14	12	M12×1.5	13
16	CFKR 35 VR	CFKR 35 V	CFKR 35 VUUR	CFKR 35 VUU	168	35	18	16	M16×1.5	17
18	CFKR 40 VR	CFKR 40 V	CFKR 40 VUUR	CFKR 40 VUU	253	40	20	18	M18×1.5	19
20	CFKR 47 VR	CFKR 47 V	CFKR 47 VUUR	CFKR 47 VUU	383	47	24	20	M20×1.5	21
	CFKR 52 VR	CFKR 52 V	CFKR 52 VUUR	CFKR 52 VUU	458	52	24	20	M20×1.5	21
24	CFKR 62 VR	CFKR 62 V	CFKR 62 VUUR	CFKR 62 VUU	800	62	29	24	M24×1.5	25
	CFKR 72 VR	CFKR 72 V	CFKR 72 VUUR	CFKR 72 VUU	1 120	72	29	24	M24×1.5	25
30	CFKR 80 VR	CFKR 80 V	CFKR 80 VUUR	CFKR 80 VUU	1 860	80	35	30	M30×1.5	32
	CFKR 85 VR	CFKR 85 V	CFKR 85 VUUR	CFKR 85 VUU	2 020	85				
	CFKR 90 VR	CFKR 90 V	CFKR 90 VUUR	CFKR 90 VUU	2 210	90				

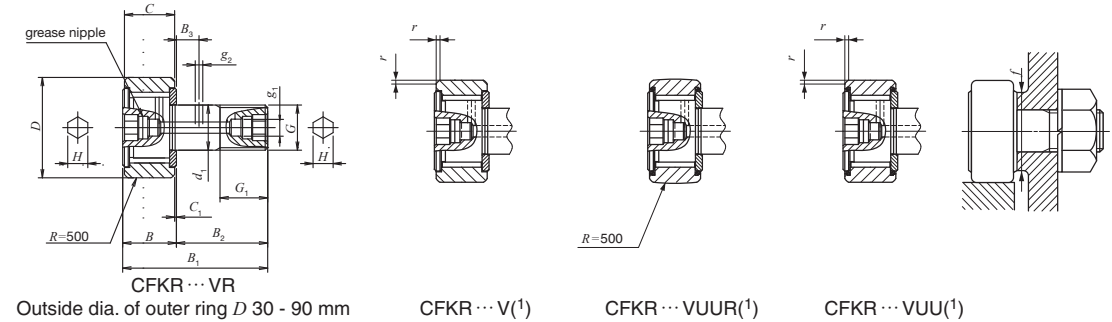
Note⁽¹⁾ For dimensions other than the chamfer dimension (r) and the shape of the outside surface of the outer ring outside surface, refer to the CFKR...VR drawing.

⁽²⁾ The identification number indicates the outer ring outside diameter.

⁽³⁾ This is the value for the product body only. The values for the accessories shown in Table 13 on page I14 are not included.

⁽⁴⁾ Minimum allowable value of chamfer dimension r.

Remark Provided with prepacked grease.



CFKR...VR
Outside dia. of outer ring D 30 - 90 mm

CFKR...V⁽¹⁾

CFKR...VUUR⁽¹⁾

CFKR...VUU⁽¹⁾

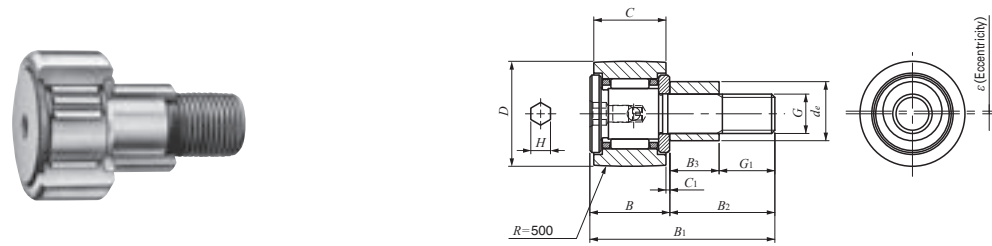
Boundary dimensions mm									Mounting dimension f Min. mm	Maximum tightening torque N·m	Basic dynamic load rating C N	Basic static load rating C ₀ N	Maximum allowable static load N
B _{max}	B _{1max}	B ₂	B ₃	C ₁	g ₁	g ₂	H	r _{s min} ⁽⁴⁾					
13.2	36.2	23	—	0.6	3	—	5	0.3	16	13.0	9 570	14 500	7 920
15.2	40.2	25	6	0.6	4	3	6	0.6	21	21.9	13 500	19 700	13 200
19.6	52.1	32.5	8	0.8	4	3	8	0.6	26	58.5	20 700	37 600	23 200
21.6	58.1	36.5	8	0.8	6	3	8	1	29	86.2	25 300	51 300	31 100
25.6	66.1	40.5	9	0.8	6	4	10	1	34	119	33 200	64 500	37 500
30.6	80.1	49.5	11	0.8	6	4	14	1	40	215	46 600	92 000	52 000
37	100	63	15	1	6	4	14	1	49	438	67 700	144 000	85 900

I

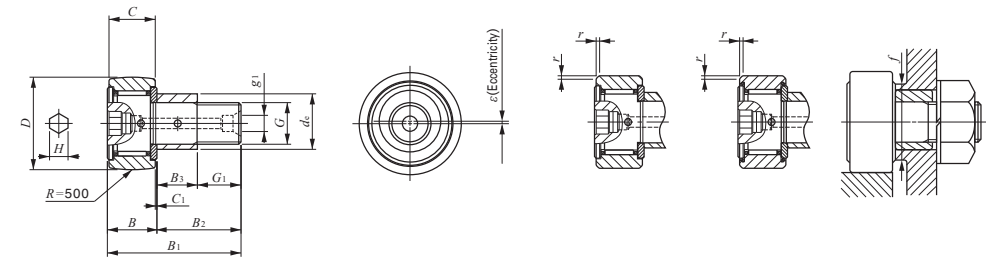
CF
CFKR
CFS
NUCF
CR

CAM FOLLOWERS

Eccentric Type Cam Followers CFE...B With Cage/Stud Head Hex Hole



CFE...BR
Outside diameter of eccentric collar d_e 9-13mm



CFE...BR(1) Outside diameter of eccentric collar d_e 16-41mm
CFE...B(1) CFE...BUU(1)

Outside diameter of eccentric collar 9—41mm

Outside diameter of eccentric collar mm	Identification number				Mass (Ref.) ⁽²⁾ g	D	C	d_e
	Shield type		Sealed type					
	With crowned outer ring	With cylindrical outer ring	With crowned outer ring	With cylindrical outer ring				
9	CFE 6 BR	CFE 6 B	CFE 6 BUUR	CFE 6 BUU	20.5	16	11	9
11	CFE 8 BR	CFE 8 B	CFE 8 BUUR	CFE 8 BUU	32	19	11	11
13	CFE 10 BR	CFE 10 B	CFE 10 BUUR	CFE 10 BUU	49.5	22	12	13
	CFE 10-1 BR	CFE 10-1 B	CFE 10-1 BUUR	CFE 10-1 BUU	65	26	12	13
16	CFE 12 BR	CFE 12 B	CFE 12 BUUR	CFE 12 BUU	105	30	14	16
	CFE 12-1 BR	CFE 12-1 B	CFE 12-1 BUUR	CFE 12-1 BUU	115	32	14	16
22	CFE 16 BR	CFE 16 B	CFE 16 BUUR	CFE 16 BUU	190	35	18	22
24	CFE 18 BR	CFE 18 B	CFE 18 BUUR	CFE 18 BUU	280	40	20	24
27	CFE 20 BR	CFE 20 B	CFE 20 BUUR	CFE 20 BUU	500	52	24	27
	CFE 20-1 BR	CFE 20-1 B	CFE 20-1 BUUR	CFE 20-1 BUU	425	47	24	27
33	CFE 24 BR	CFE 24 B	CFE 24 BUUR	CFE 24 BUU	895	62	29	33
	CFE 24-1 BR	CFE 24-1 B	CFE 24-1 BUUR	CFE 24-1 BUU	1 220	72	29	33
41	CFE 30 BR	CFE 30 B	CFE 30 BUUR	CFE 30 BUU	2 030	80	35	41
	CFE 30-1 BR	CFE 30-1 B	CFE 30-1 BUUR	CFE 30-1 BUU	2 190	85	35	41
	CFE 30-2 BR	CFE 30-2 B	CFE 30-2 BUUR	CFE 30-2 BUU	2 380	90	35	41

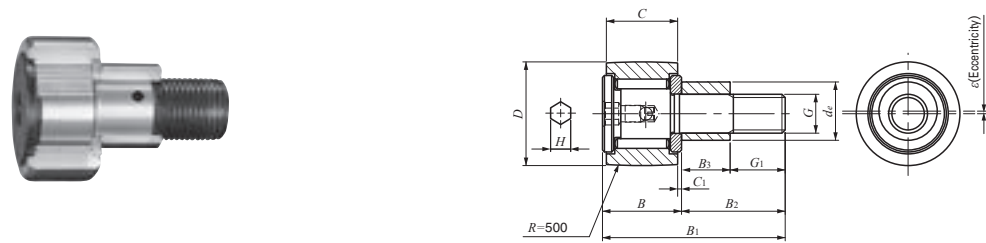
Note⁽¹⁾ For dimensions other than the chamfer dimension (r) and the shape of the outside surface of the outer ring outside surface, refer to the CFE...BR drawing.
⁽²⁾ This is the value for the product body only. The values for the accessories shown in Table 13 on page I14 are not included.
⁽³⁾ Minimum allowable value of chamfer dimension r
 Remarks1. Models with a thread diameter G of 10 mm or less have an oil hole (re-greasing fitting) at the head. Other models are provided with an oil hole (grease nipple) at the head and an oil hole on the end surface of the stud.
 2. Shield type models with a stud thread diameter G of 10 mm or less and the sealed type models are provided with prepacked grease. Other models are not provided with prepacked grease. Perform proper lubrication for use.

Boundary dimensions mm												Mounting dimension f Min. mm	Maximum tightening torque N-m	Basic dynamic load rating C N	Basic static load rating C_0 N	Maximum allowable static load N
G	B_3	B_{max}	B_{1max}	B_2	C_1	g_1	G_1	H	$r_{smin}^{(3)}$	Eccentricity ϵ	Eccentricity ϵ					
M 6×1	7.5	12.2	28.2	16	0.6	—	8.5	3	0.3	0.4	11	2.7	3 660	3 650	1 950	
M 8×1.25	9.5	12.2	32.2	20	0.6	—	10.5	4	0.3	0.4	13	6.5	4 250	4 740	4 620	
M10×1.25	10.5	13.2	36.2	23	0.6	—	12.5	4	0.3	0.4	16	13.8	5 430	6 890	6 890	
M10×1.25	10.5	13.2	36.2	23	0.6	—	12.5	4	0.3	0.4	16	13.8	5 430	6 890	6 890	
M12×1.5	11.5	15.2	40.2	25	0.6	4	13.5	6	0.6	0.8	21	21.9	7 910	9 790	9 790	
M12×1.5	11.5	15.2	40.2	25	0.6	4	13.5	6	0.6	0.8	21	21.9	7 910	9 790	9 790	
M16×1.5	15.5	19.6	52.1	32.5	0.8	4	17	6	0.6	0.8	26	58.5	12 000	18 300	18 300	
M18×1.5	17.5	21.6	58.1	36.5	0.8	6	19	8	1	0.8	29	86.2	14 800	25 200	25 200	
M20×1.5	19.5	25.6	66.1	40.5	0.8	6	21	8	1	0.8	34	119	20 700	34 600	34 600	
M20×1.5	19.5	25.6	66.1	40.5	0.8	6	21	8	1	0.8	34	119	20 700	34 600	34 600	
M24×1.5	25.5	30.6	80.1	49.5	0.8	6	24	12	1	0.8	40	215	30 500	52 600	52 000	
M24×1.5	25.5	30.6	80.1	49.5	0.8	6	24	12	1	0.8	40	215	30 500	52 600	52 000	
M30×1.5	32.5	37	100	63	1	6	30.5	17	1	1.5	49	438	45 400	85 100	85 100	
M30×1.5	32.5	37	100	63	1	6	30.5	17	1	1.5	49	438	45 400	85 100	85 100	
M30×1.5	32.5	37	100	63	1	6	30.5	17	1	1.5	49	438	45 400	85 100	85 100	

I
CF
CFKR
CFS
NUCF
CR

CAM FOLLOWERS

Eccentric Type Cam Followers CFE...B Full Complement Type/Stud Head Hex Hole

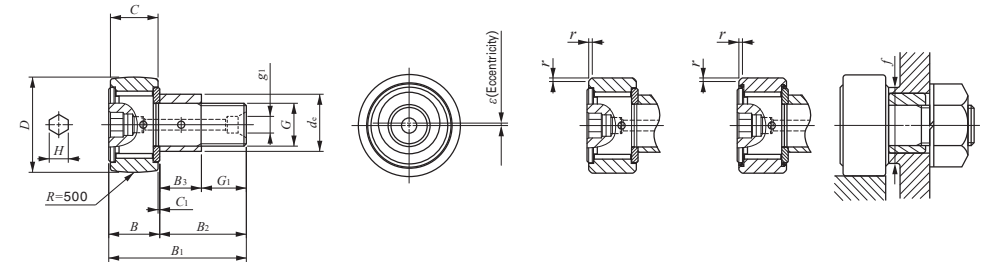


CFE...VBR Outside diameter of eccentric collar d_e 9-13mm

Outside diameter of eccentric collar 9—41mm

Outside diameter of eccentric collar mm	Identification number				Mass (Ref.) ⁽²⁾ g	D	C	d_e
	Shield type		Sealed type					
	With crowned outer ring	With cylindrical outer ring	With crowned outer ring	With cylindrical outer ring				
9	CFE 6 VBR	CFE 6 VB	CFE 6 VBUUR	CFE 6 VBUU	21	16	11	9
11	CFE 8 VBR	CFE 8 VB	CFE 8 VBUUR	CFE 8 VBUU	32.5	19	11	11
13	CFE 10 VBR	CFE 10 VB	CFE 10 VBUUR	CFE 10 VBUU	50.5	22	12	13
	CFE 10-1 VBR	CFE 10-1 VB	CFE 10-1 VBUUR	CFE 10-1 VBUU	66	26	12	13
16	CFE 12 VBR	CFE 12 VB	CFE 12 VBUUR	CFE 12 VBUU	107	30	14	16
	CFE 12-1 VBR	CFE 12-1 VB	CFE 12-1 VBUUR	CFE 12-1 VBUU	117	32	14	16
22	CFE 16 VBR	CFE 16 VB	CFE 16 VBUUR	CFE 16 VBUU	193	35	18	22
24	CFE 18 VBR	CFE 18 VB	CFE 18 VBUUR	CFE 18 VBUU	285	40	20	24
27	CFE 20 VBR	CFE 20 VB	CFE 20 VBUUR	CFE 20 VBUU	505	52	24	27
	CFE 20-1 VBR	CFE 20-1 VB	CFE 20-1 VBUUR	CFE 20-1 VBUU	430	47	24	27
33	CFE 24 VBR	CFE 24 VB	CFE 24 VBUUR	CFE 24 VBUU	900	62	29	33
	CFE 24-1 VBR	CFE 24-1 VB	CFE 24-1 VBUUR	CFE 24-1 VBUU	1 220	72	29	33
41	CFE 30 VBR	CFE 30 VB	CFE 30 VBUUR	CFE 30 VBUU	2 030	80	35	41
	CFE 30-1 VBR	CFE 30-1 VB	CFE 30-1 VBUUR	CFE 30-1 VBUU	2 190	85	35	41
	CFE 30-2 VBR	CFE 30-2 VB	CFE 30-2 VBUUR	CFE 30-2 VBUU	2 380	90	35	41

Note⁽¹⁾ For dimensions other than the chamfer dimension (r) and the shape of the outside surface of the outer ring outside surface, refer to the CFE...VBR drawing.
⁽²⁾ This is the value for the product body only. The values for the accessories shown in Table 13 on page I14 are not included.
⁽³⁾ Minimum allowable value of chamfer dimension r
 Remarks1. Models with a thread diameter G of 10 mm or less have an oil hole (re-greasing fitting) at the head. Other models are provided with an oil hole (grease nipple) at the head and an oil hole on the end surface of the stud.
 2. Provided with prepacked grease.



CFE...VBR⁽¹⁾ CFE...VB⁽¹⁾ CFE...VBUU⁽¹⁾
 Outside diameter of eccentric collar d_e 16-41mm

Boundary dimensions mm											Mounting dimension f Min. mm	Maximum tightening torque N·m	Basic dynamic load rating C N	Basic static load rating C_0 N	Maximum allowable static load N
G	B_3	B_{max}	B_{1max}	B_2	C_1	g_1	G_1	H	$r_{smin}^{(3)}$	Eccentricity ϵ					
M 6×1	7.5	12.2	28.2	16	0.6	—	8.5	3	0.3	0.4	11	2.7	6 980	8 500	1 950
M 8×1.25	9.5	12.2	32.2	20	0.6	—	10.5	4	0.3	0.4	13	6.5	8 170	11 200	4 620
M10×1.25	10.5	13.2	36.2	23	0.6	—	12.5	4	0.3	0.4	16	13.8	9 570	14 500	8 650
M10×1.25	10.5	13.2	36.2	23	0.6	—	12.5	4	0.3	0.4	16	13.8	9 570	14 500	8 650
M12×1.5	11.5	15.2	40.2	25	0.6	4	13.5	6	0.6	0.8	21	21.9	13 500	19 700	13 200
M12×1.5	11.5	15.2	40.2	25	0.6	4	13.5	6	0.6	0.8	21	21.9	13 500	19 700	13 200
M16×1.5	15.5	19.6	52.1	32.5	0.8	4	17	6	0.6	0.8	26	58.5	20 700	37 600	23 200
M18×1.5	17.5	21.6	58.1	36.5	0.8	6	19	8	1	0.8	29	86.2	25 300	51 300	31 100
M20×1.5	19.5	25.6	66.1	40.5	0.8	6	21	8	1	0.8	34	119	33 200	64 500	37 500
M20×1.5	19.5	25.6	66.1	40.5	0.8	6	21	8	1	0.8	34	119	33 200	64 500	37 500
M24×1.5	25.5	30.6	80.1	49.5	0.8	6	24	12	1	0.8	40	215	46 600	92 000	52 000
M24×1.5	25.5	30.6	80.1	49.5	0.8	6	24	12	1	0.8	40	215	46 600	92 000	52 000
M30×1.5	32.5	37	100	63	1	6	30.5	17	1	1.5	49	438	67 700	144 000	85 900
M30×1.5	32.5	37	100	63	1	6	30.5	17	1	1.5	49	438	67 700	144 000	85 900
M30×1.5	32.5	37	100	63	1	6	30.5	17	1	1.5	49	438	67 700	144 000	85 900

I
 CF
 CFKR
 CFS
 NUCF
 CR

CAM FOLLOWERS

Eccentric Type Cam Followers CFKRE With Cage/Double Hex Hole

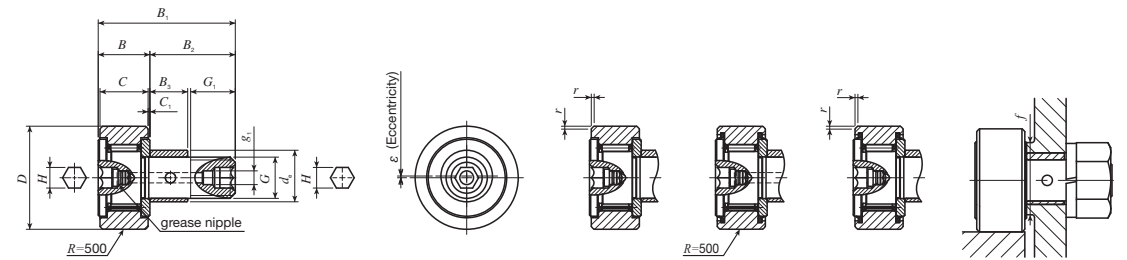


CFKRE...R
Outside diameter of eccentric collar d_e 13mm

Outside diameter of eccentric collar 13–35mm

Outside diameter of eccentric collar mm	Identification number ⁽²⁾				Mass (Ref.) g ⁽³⁾	D	C	d_e
	Shield type		Sealed type					
	Crowned outer ring	Cylindrical outer ring	Crowned outer ring	Cylindrical outer ring				
13	CFKRE 22 R	CFKRE 22	CFKRE 22 UUR	CFKRE 22 UU	47	22	12	13
	CFKRE 26 R	CFKRE 26	CFKRE 26 UUR	CFKRE 26 UU	62	26	12	13
15	CFKRE 30 R	CFKRE 30	CFKRE 30 UUR	CFKRE 30 UU	100	30	14	15
	CFKRE 32 R	CFKRE 32	CFKRE 32 UUR	CFKRE 32 UU	110	32	14	15
20	CFKRE 35 R	CFKRE 35	CFKRE 35 UUR	CFKRE 35 UU	177	35	18	20
22	CFKRE 40 R	CFKRE 40	CFKRE 40 UUR	CFKRE 40 UU	264	40	20	22
24	CFKRE 47 R	CFKRE 47	CFKRE 47 UUR	CFKRE 47 UU	397	47	24	24
	CFKRE 52 R	CFKRE 52	CFKRE 52 UUR	CFKRE 52 UU	472	52	24	24
28	CFKRE 62 R	CFKRE 62	CFKRE 62 UUR	CFKRE 62 UU	823	62	29	28
	CFKRE 72 R	CFKRE 72	CFKRE 72 UUR	CFKRE 72 UU	1 150	72	29	28
35	CFKRE 80 R	CFKRE 80	CFKRE 80 UUR	CFKRE 80 UU	1 920	80		
	CFKRE 85 R	CFKRE 85	CFKRE 85 UUR	CFKRE 85 UU	2 080	85	35	35
	CFKRE 90 R	CFKRE 90	CFKRE 90 UUR	CFKRE 90 UU	2 270	90		

Note⁽¹⁾ For dimensions other than the chamfer dimension (r) and the shape of the outside surface of the outer ring outside surface, refer to the CFKRE...R drawing.
⁽²⁾ The identification number indicates the outer ring outside diameter.
⁽³⁾ This is the value for the product body only. The values for the accessories shown in Table 13 on page 114 are not included.
⁽⁴⁾ Minimum allowable value of chamfer dimension r .
 Remark Grease is pre-packed if the eccentric collar outer diameter d_e of the shield type is 13 mm or less or if the seal structure is the sealed type. Other models are not provided with pre-packed grease. Perform proper lubrication for use.



CFKRE...R
Outside diameter of eccentric collar d_e 15~35mm

CFKRE⁽¹⁾ CFKRE...UUR⁽¹⁾ CFKRE...UU⁽¹⁾

G	Boundary dimensions mm										Eccentricity ϵ	Mounting dimension f Min. mm	Maximum tightening torque N·m	Basic dynamic load rating C N	Basic static load rating C_0 N	Maximum allowable static load N
	G_1	B max	B ₁ max	B ₂	B ₃	C ₁	g_1	H	r_{smin} ⁽⁴⁾	ϵ						
M10×1.0	12	13.2	36.2	23	10	0.6	3	5	0.3	0.5	16	13.0	5 430	6 890	6 890	
M12×1.5	13	15.2	40.2	25	11	0.6	4	6	0.6	0.5	21	21.9	7 910	9 790	9 790	
M16×1.5	17	19.6	52.1	32.5	14	0.8	4	8	0.6	1	26	58.5	12 000	18 300	18 300	
M18×1.5	19	21.6	58.1	36.5	16	0.8	6	8	1	1	29	86.2	14 800	25 200	25 200	
M20×1.5	21	25.6	66.1	40.5	18	0.8	6	10	1	1	34	119	20 700	34 600	34 600	
M24×1.5	25	30.6	80.1	49.5	22	0.8	6	14	1	1	40	215	30 500	52 600	52 000	
M30×1.5	32	37	100	63	29	1	6	14	1	1.5	49	438	45 400	85 100	85 100	

I
CF
CFKR
CFS
NUCF
CR

CAM FOLLOWERS

Eccentric Type Cam Followers CFKRE Full complement/Double Hex Hole

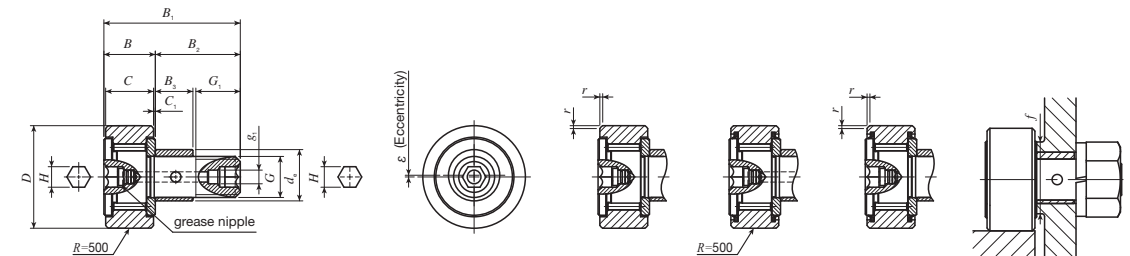


CFKRE...VR
Outside diameter of eccentric collar d_e 13mm

Outside diameter of eccentric collar 13–35mm

Outside diameter of eccentric collar mm	Identification number ⁽²⁾				Mass (Ref.) g ⁽³⁾	D	C	d_e
	Shield type		Sealed type					
	Crowned outer ring	Cylindrical outer ring	Crowned outer ring	Cylindrical outer ring				
13	CFKRE 22 VR	CFKRE 22 V	CFKRE 22 VUUR	CFKRE 22 VUU	48	22	12	13
	CFKRE 26 VR	CFKRE 26 V	CFKRE 26 VUUR	CFKRE 26 VUU	63	26	12	13
15	CFKRE 30 VR	CFKRE 30 V	CFKRE 30 VUUR	CFKRE 30 VUU	101	30	14	15
	CFKRE 32 VR	CFKRE 32 V	CFKRE 32 VUUR	CFKRE 32 VUU	111	32	14	15
20	CFKRE 35 VR	CFKRE 35 V	CFKRE 35 VUUR	CFKRE 35 VUU	180	35	18	20
22	CFKRE 40 VR	CFKRE 40 V	CFKRE 40 VUUR	CFKRE 40 VUU	269	40	20	22
24	CFKRE 47 VR	CFKRE 47 V	CFKRE 47 VUUR	CFKRE 47 VUU	402	47	24	24
	CFKRE 52 VR	CFKRE 52 V	CFKRE 52 VUUR	CFKRE 52 VUU	477	52	24	24
28	CFKRE 62 VR	CFKRE 62 V	CFKRE 62 VUUR	CFKRE 62 VUU	828	62	29	28
	CFKRE 72 VR	CFKRE 72 V	CFKRE 72 VUUR	CFKRE 72 VUU	1 150	72	29	28
35	CFKRE 80 VR	CFKRE 80 V	CFKRE 80 VUUR	CFKRE 80 VUU	1 920	80	35	35
	CFKRE 85 VR	CFKRE 85 V	CFKRE 85 VUUR	CFKRE 85 VUU	2 080	85	35	35
	CFKRE 90 VR	CFKRE 90 V	CFKRE 90 VUUR	CFKRE 90 VUU	2 270	90	35	35

Note⁽¹⁾ For dimensions other than the chamfer dimension (r) and the shape of the outside surface of the outer ring outside surface, refer to the CFKRE...VR drawing.
⁽²⁾ The identification number indicates the outer ring outside diameter.
⁽³⁾ This is the value for the product body only. The values for the accessories shown in Table 13 on page 114 are not included.
⁽⁴⁾ Minimum allowable value of chamfer dimension r .
 Remark Grease is prepacked.



CFKRE...VR
Outside diameter of eccentric collar d_e 15~35mm

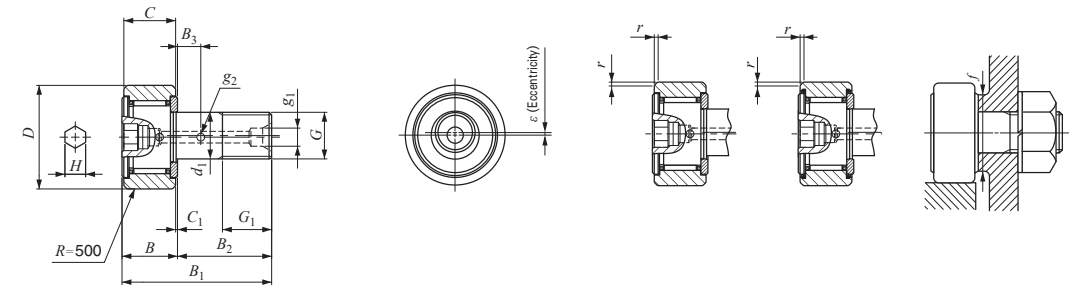
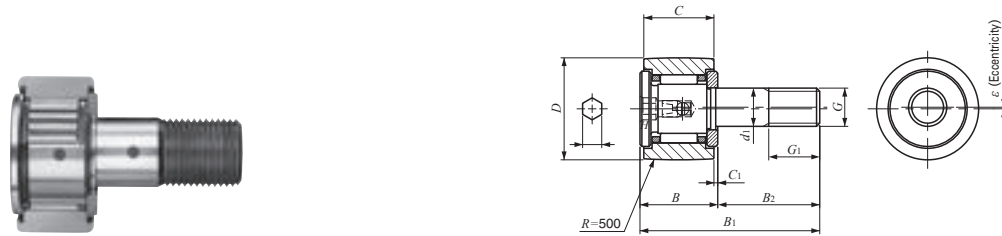
CFKRE...V⁽¹⁾ CFKRE...VUU⁽¹⁾ CFKRE...VUUR⁽¹⁾

G	Boundary dimensions mm									Eccentricity ϵ	Mounting dimension f Min. mm	Maximum tightening torque N-m	Basic dynamic load rating C N	Basic static load rating C_0 N	Maximum allowable static load N
	G_1	B max	B_1 max	B_2	B_3	C_1	g_1	H	r_{smin} ⁽⁴⁾						
M10×1.0	12	13.2	36.2	23	10	0.6	3	5	0.3	0.5	16	13.0	9 570	14 500	7 920
M12×1.5	13	15.2	40.2	25	11	0.6	4	6	0.6	0.5	21	21.9	13 500	19 700	13 200
M16×1.5	17	19.6	52.1	32.5	14	0.8	4	8	0.6	1	26	58.5	20 700	37 600	23 200
M18×1.5	19	21.6	58.1	36.5	16	0.8	6	8	1	1	29	86.2	25 300	51 300	31 100
M20×1.5	21	25.6	66.1	40.5	18	0.8	6	10	1	1	34	119	33 200	64 500	37 500
M24×1.5	25	30.6	80.1	49.5	22	0.8	6	14	1	1	40	215	46 600	92 000	52 000
M30×1.5	32	37	100	63	29	1	6	14	1	1.5	49	438	67 700	144 000	85 900

I
CF
CFKR
CFS
NUCF
CR

CAM FOLLOWERS

Solid Eccentric Stud Type Cam Followers With Cage/Stud Head Hex Hole



Stud dia. 6—18mm

CFES...BR
Stud dia. d_1 6-10mm

CFES...BR
Stud dia. d_1 12-18mm

CFES...B(1) CFES...BUU(1)

Stud dia. mm	Identification number				Mass (Ref.) ⁽²⁾ g	D	C	d_1
	Shield type		Sealed type					
	With crowned outer ring	With cylindrical outer ring	With crowned outer ring	With cylindrical outer ring				
6	CFES 6 BR	CFES 6 B	CFES 6 BUUR	CFES 6 BUU	18.5	16	11	6
8	CFES 8 BR	CFES 8 B	CFES 8 BUUR	CFES 8 BUU	28.5	19	11	8
10	CFES 10 BR	CFES 10 B	CFES 10 BUUR	CFES 10 BUU	45	22	12	10
	CFES 10-1 BR	CFES 10-1 B	CFES 10-1 BUUR	CFES 10-1 BUU	60	26	12	10
12	CFES 12 BR	CFES 12 B	CFES 12 BUUR	CFES 12 BUU	95	30	14	12
	CFES 12-1 BR	CFES 12-1 B	CFES 12-1 BUUR	CFES 12-1 BUU	105	32	14	12
16	CFES 16 BR	CFES 16 B	CFES 16 BUUR	CFES 16 BUU	170	35	18	16
18	CFES 18 BR	CFES 18 B	CFES 18 BUUR	CFES 18 BUU	250	40	20	18

Note⁽¹⁾ For dimensions other than the chamfer dimension (r) and the shape of the outside surface of the outer ring outside surface, refer to the CFES...BR drawing.

⁽²⁾ This is the value for the product body only. The values for the accessories shown in Table 13 on page I14 are not included.

⁽³⁾ Minimum allowable value of chamfer dimension r

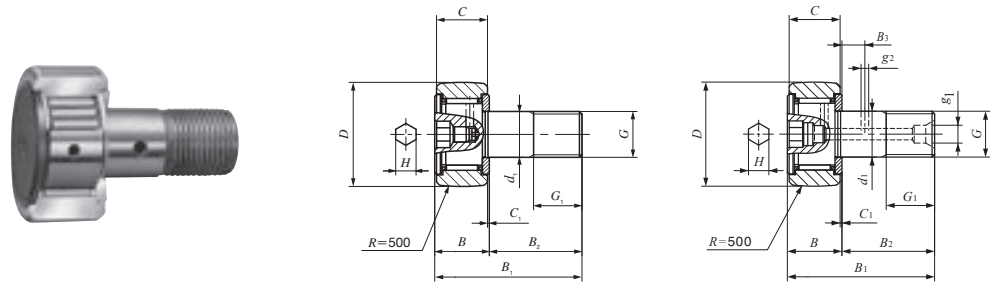
Remarks1. Models with a stud diameter d_1 of 10 mm or less have an oil hole (re-greasing fitting) at the head. Other models are provided with an oil hole (grease nipple) at the head and an oil hole each on the outside surface and end surface of the stud.
2. Shield type models with a stud diameter d_1 of 10 mm or less and the sealed type models are provided with prepacked grease. Other models are not provided with prepacked grease. Perform proper lubrication for use.

Boundary dimensions mm													Eccentricity ϵ	Mounting dimension f Min. mm	Maximum tightening torque N-m	Basic dynamic load rating C N	Basic static load rating C_0 N	Maximum allowable static load N
G	G_1	B_{max}	B_{1max}	B_2	B_3	C_1	g_1	g_2	H	$r_{smin}^{(3)}$	ϵ							
M 6×1	8	12.2	28.2	16	—	0.6	—	—	3	0.3	0.25	11	2.7	3 660	3 650	1 980		
M 8×1.25	10	12.2	32.2	20	—	0.6	—	—	4	0.3	0.25	13	6.5	4 250	4 740	4 670		
M10×1.25	12	13.2	36.2	23	—	0.6	—	—	4	0.3	0.3	16	13.8	5 430	6 890	6 890		
M10×1.25	12	13.2	36.2	23	—	0.6	—	—	4	0.3	0.3	16	13.8	5 430	6 890	6 890		
M12×1.5	13	15.2	40.2	25	6	0.6	4	3	6	0.6	0.4	21	21.9	7 910	9 790	9 790		
M12×1.5	13	15.2	40.2	25	6	0.6	4	3	6	0.6	0.4	21	21.9	7 910	9 790	9 790		
M16×1.5	17	19.6	52.1	32.5	8	0.8	4	3	6	0.6	0.5	26	58.5	12 000	18 300	18 300		
M18×1.5	19	21.6	58.1	36.5	8	0.8	6	3	8	1	0.6	29	86.2	14 800	25 200	25 200		

I
CF
CFKR
CFS
NUCF
CR

CAM FOLLOWERS

Thrust Disk Type Cam Followers With Cage/Stud Head Hex Hole



Stud dia. 3 – 20mm

CF...WBR
Stud dia. d_1 3-10mm

CF...WBR
Stud dia. d_1 12-20mm

Stud dia. mm	Identification number		Mass (Ref.) g ⁽²⁾	Boundary dimensions mm				
	Shield type	Sealed type		D	C	d_1	G	G_1
3	CF 3 WBR	CF 3 WBUUR	4.3	10	7	3	M 3×0.5	5
4	CF 4 WBR	CF 4 WBUUR	7.4	12	8	4	M 4×0.7	6
5	CF 5 WBR	CF 5 WBUUR	10.3	13	9	5	M 5×0.8	7.5
6	CF 6 WBR	CF 6 WBUUR	18.5	16	11	6	M 6×1	8
8	CF 8 WBR	CF 8 WBUUR	28.5	19	11	8	M 8×1.25	10
10	CF 10 WBR	CF 10 WBUUR	45	22	12	10	M10×1.25	12
	CF 10-1 WBR	CF 10-1 WBUUR	60	26	12	10	M10×1.25	12
12	CF 12 WBR	CF 12 WBUUR	95	30	14	12	M12×1.5	13
	CF 12-1 WBR	CF 12-1 WBUUR	105	32	14	12	M12×1.5	13
16	CF 16 WBR	CF 16 WBUUR	170	35	18	16	M16×1.5	17
18	CF 18 WBR	CF 18 WBUUR	250	40	20	18	M18×1.5	19
20	CF 20 WBR	CF 20 WBUUR	460	52	24	20	M20×1.5	21
	CF 20-1 WBR	CF 20-1 WBUUR	385	47	24	20	M20×1.5	21

Note⁽¹⁾ For other dimensions, refer to the CF...WBR drawing.

⁽²⁾ This is the value for the product body only. The values for the accessories shown in Table 13 on page I14 are not included.

Remarks1. Models with a stud diameter d_1 of 4 mm or less have no oil hole. For Models with a stud dia. 5 to 10 mm, oil hole (re-greasing fitting) is provided at the head. Other models are provided with an oil hole (grease nipple) at the head and an oil hole each on the outside surface and end surface of the stud.

2. Shield type models with a stud diameter d_1 of 10 mm or less and the sealed type models are provided with prepacked grease. Other models are not provided with prepacked grease. Perform proper lubrication for use.



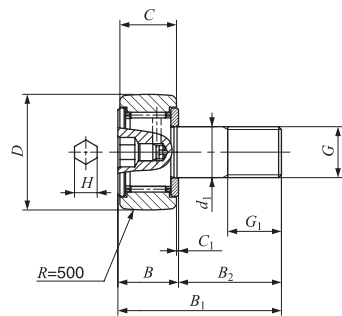
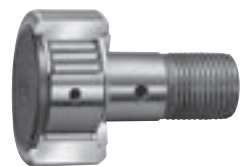
CF...WBUUR⁽¹⁾

B	B_1	B_2	B_3	C_1	g_1	g_2	H	Mounting dimension f Min. mm	Maximum tightening torque N·m	Basic dynamic load rating C N	Basic static load rating C_0 N	Maximum allowable static load N
9	20	11	—	0.5	—	—	2.5	8.3	0.78	2 070	1 590	834
10	23	13	—	0.5	—	—	3	9.3	1.6	2 520	2 140	1 260
12.2 max	28.2 max	16	—	0.6	—	—	3	11	2.7	3 660	3 650	1 950
12.2 max	32.2 max	20	—	0.6	—	—	4	13	6.5	4 250	4 740	4 620
13.2 max	36.2 max	23	—	0.6	—	—	4	16	13.8	5 430	6 890	6 890
13.2 max	36.2 max	23	—	0.6	—	—	4	16	13.8	5 430	6 890	6 890
15.2 max	40.2 max	25	6	0.6	4	3	6	21	21.9	7 910	9 790	9 790
15.2 max	40.2 max	25	6	0.6	4	3	6	21	21.9	7 910	9 790	9 790
19.6 max	52.1 max	32.5	8	0.8	4	3	6	26	58.5	12 000	18 300	18 300
21.6 max	58.1 max	36.5	8	0.8	6	3	8	29	86.2	14 800	25 200	25 200
25.6 max	66.1 max	40.5	9	0.8	6	4	8	34	119	20 700	34 600	34 600
25.6 max	66.1 max	40.5	9	0.8	6	4	8	34	119	20 700	34 600	34 600

I
CF
CFKR
CFS
NUCF
CR

CAM FOLLOWERS

Thrust Disk Type Cam Followers / Stainless Steel Made **With Cage/Stud Head Hex Hole**



Stud dia. 3 – 5mm

CF...FWBR

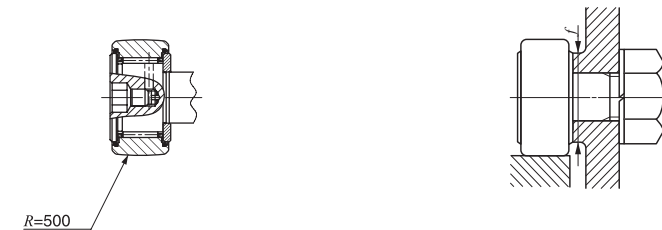
Stud dia. mm	Identification number		Mass (Ref.) g ⁽²⁾	Boundary dimensions mm				
	Shield type	Sealed type		D	C	d ₁	G	G ₁
3	CF 3 FWBR	CF 3 FWBUUR	4.3	10	7	3	M 3 × 0.5	5
4	CF 4 FWBR	CF 4 FWBUUR	7.4	12	8	4	M 4 × 0.7	6
5	CF 5 FWBR	CF 5 FWBUUR	10.3	13	9	5	M 5 × 0.8	7.5

Note⁽¹⁾ For other dimensions, refer to the CF...FWBR drawing.

⁽²⁾ This is the value for the product body only. The values for the accessories shown in Table 13 on page I14 are not included.

Remarks1. Models with a stud diameter d₁ of 4 mm or less have no oil hole. For Models with a stud dia. 5 mm, oil hole (re-greasing fitting) is provided at the head.

2. Provided with prepacked grease.



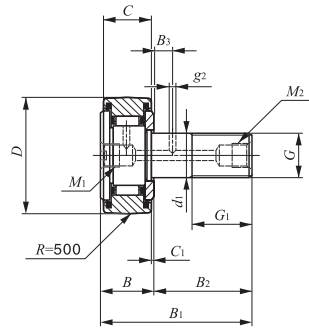
CF...FWBUUR⁽¹⁾

								Mounting dimension f Min. mm	Maximum tightening torque N-m	Basic dynamic load rating C N	Basic static load rating C ₀ N	Maximum allowable static load N
B	B ₁	B ₂	B ₃	C ₁	g ₁	g ₂	H					
8	17	9	—	0.5	—	—	2	6.8	0.34	1 200	813	384
9	20	11	—	0.5	—	—	2.5	8.3	0.78	1 650	1 270	834
10	23	13	—	0.5	—	—	3	9.3	1.6	1 930	1 730	1 260

I
CF
CFKR
CFS
NUCF
CR

CAM FOLLOWERS

Centralized Lubrication Type Cam Followers With Cage/Stud Head Hex Hole



CF-RU1

Stud dia. 6 – 30mm

Stud dia. mm	Identification number		Mass (Ref.) g ⁽²⁾	Boundary dimensions mm				
	With crowned outer ring	With cylindrical outer ring		D	C	d ₁	G	G ₁
6	CF-RU1- 6	CF-FU1- 6	18.5	16	11	6	M 6 × 1	8
8	CF-RU1- 8	CF-FU1- 8	28.5	19	11	8	M 8 × 1.25	10
10	CF-RU1-10	CF-FU1-10	45	22	12	10	M10 × 1.25	12
	CF-RU1-10-1	CF-FU1-10-1	60	26	12	10	M10 × 1.25	12
12	CF-RU1-12	CF-FU1-12	95	30	14	12	M12 × 1.5	13
	CF-RU1-12-1	CF-FU1-12-1	105	32	14	12	M12 × 1.5	13
16	CF-RU1-16	CF-FU1-16	170	35	18	16	M16 × 1.5	17
18	CF-RU1-18	CF-FU1-18	250	40	20	18	M18 × 1.5	19
20	CF-RU1-20	CF-FU1-20	460	52	24	20	M20 × 1.5	21
	CF-RU1-20-1	CF-FU1-20-1	385	47	24	20	M20 × 1.5	21
24	CF-RU1-24	CF-FU1-24	815	62	29	24	M24 × 1.5	25
	CF-RU1-24-1	CF-FU1-24-1	1 140	72	29	24	M24 × 1.5	25
30	CF-RU1-30	CF-FU1-30	1 870	80	35	30	M30 × 1.5	32
	CF-RU1-30-1	CF-FU1-30-1	2 030	85	35	30	M30 × 1.5	32
	CF-RU1-30-2	CF-FU1-30-2	2 220	90	35	30	M30 × 1.5	32

Note⁽¹⁾ For dimensions other than the chamfer dimension (r) and the shape of the outside surface of the outer ring outside surface, refer to the CF-RU1 drawing.

⁽²⁾ This is the value for the product body only. The values for the accessories shown in Table 13 on page I14 are not included.

⁽³⁾ Minimum allowable value of chamfer dimension r

Remarks1. Models with a stud diameter d₁ of 12 mm or less are provided with a lubrication tapped hole on the stud head only. Other models are provided with one lubrication tapped hole each on the head and end surface of the stud.

2. Provided with prepacked grease.



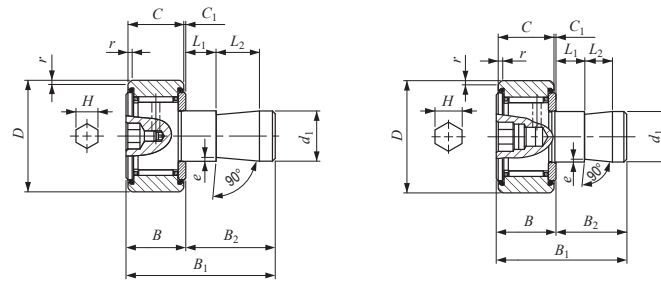
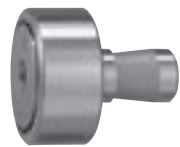
CF-FU1⁽¹⁾

B _{max}	B _{1max}	B ₂	B ₃	C ₁	g ₂	M ₁	M ₂	r _{s min} ⁽³⁾	Mounting dimension f Min. mm	Maximum tightening torque N-m	Basic dynamic load rating C N	Basic static load rating C ₀ N	Maximum allowable static load N
12.2	28.2	16	—	0.6	—	M6 × 0.75	—	0.3	11	2.7	3 660	3 650	1 950
12.2	32.2	20	—	0.6	—			0.3	13	6.5	4 250	4 740	4 620
13.2	36.2	23	—	0.6	—			0.3	16	13.8	5 430	6 890	6 890
13.2	36.2	23	—	0.6	—			0.3	16	13.8	5 430	6 890	6 890
15.2	40.2	25	—	0.6	—	PT 1/8	PT 1/8	0.6	21	23.9	7 910	9 790	9 790
15.2	40.2	25	—	0.6	—			0.6	21	23.9	7 910	9 790	9 790
19.6	52.1	32.5	8	0.8	3			0.6	26	58.5	12 000	18 300	18 300
21.6	58.1	36.5	8	0.8	3			1	29	86.2	14 800	25 200	25 200
25.6	66.1	40.5	9	0.8	4	PT 1/8	PT 1/8	1	34	119	20 700	34 600	34 600
25.6	66.1	40.5	9	0.8	4			1	34	119	20 700	34 600	34 600
30.6	80.1	49.5	11	0.8	4			1	40	215	30 500	52 600	52 000
30.6	80.1	49.5	11	0.8	4			1	40	215	30 500	52 600	52 000
37	100	63	15	1	4	PT 1/8	PT 1/8	1	49	438	45 400	85 100	85 100
37	100	63	15	1	4			1	49	438	45 400	85 100	85 100
37	100	63	15	1	4			1	49	438	45 400	85 100	85 100

I
CF
CFKR
CFS
NUCF
CR

CAM FOLLOWERS

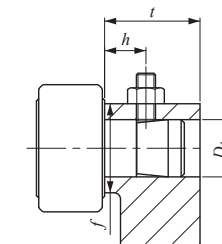
Easy Mounting Type Cam Followers **With Cage/Stud Head Hex Hole**



CF-SFU...B
Stud dia. d_1 6-10mm

CF-SFU...B
Stud dia. d_1 12-20mm

Stud dia. 6 – 20mm



Stud dia. mm	Identification number	Mass (Ref.) g	Boundary dimensions mm							
			D	C	d_1	B_{max}	B_{1max}	B_2	C_1	L_1
6	CF-SFU- 6 B	19.5	16	11	6	12.2	32	19.8	0.6	5
8	CF-SFU- 8 B	29	19	11	8	12.2	32	19.8	0.6	5
10	CF-SFU-10 B	44	22	12	10	13.2	33	19.8	0.6	5
	CF-SFU-10-1 B	59	26	12	10	13.2	33	19.8	0.6	5
12	CF-SFU-12 B	94	30	14	12	15.2	35	19.8	0.6	5
	CF-SFU-12-1 B	104	32	14	12	15.2	35	19.8	0.6	5
16	CF-SFU-16 B	164	35	18	16	19.6	44.5	24.9	0.8	10
18	CF-SFU-18 B	235	40	20	18	21.6	46.5	24.9	0.8	10
20	CF-SFU-20 B	435	52	24	20	25.6	50.5	24.9	0.8	10
	CF-SFU-20-1 B	360	47	24	20	25.6	50.5	24.9	0.8	10

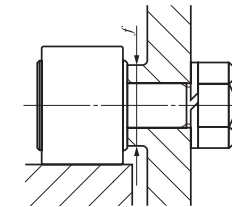
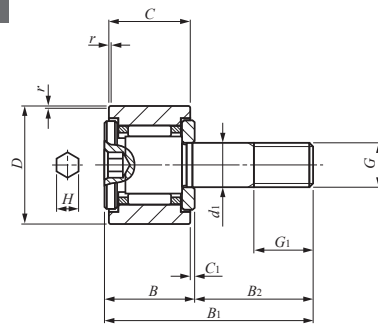
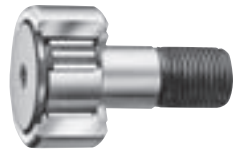
Note(1) Minimum allowable value of chamfer dimension r
 Remarks1. Models with a stud diameter d_1 of 10 mm or less have an oil hole (re-greasing fitting) at the head. Other models are provided with an oil hole (grease nipple) at the head.
 2. Provided with prepacked grease.

				Mounting dimensions mm					Basic dynamic load rating	Basic static load rating	Maximum allowable static load
L_2	H	e	$r_{s min}^{(1)}$	D_1	Tolerance	t Min.	f Min.	h (Ref.)	C N	C_0 N	N
10	3	0.3	0.3	6	+0.012 0	20	11	10	3 660	3 650	1 950
10	4	0.5	0.3	8	+0.015 0	20	13	10	4 250	4 740	4 620
10	4	0.5	0.3	10		20	16	10	5 430	6 890	6 890
10	4	0.5	0.3	10		20	16	10	5 430	6 890	6 890
10	6	1	0.6	12	+0.018 0	20	21	10	7 910	9 790	9 790
10	6	1	0.6	12		20	21	10	7 910	9 790	9 790
10	6	1	0.6	16		25	26	15	12 000	18 300	18 300
10	8	1	1	18	+0.021 0	25	29	15	14 800	25 200	25 200
10	8	1	1	20		25	34	15	20 700	34 600	34 600
10	8	1	1	20		25	34	15	20 700	34 600	34 600

I
CF
CFKR
CFS
NUCF
CR

CAM FOLLOWERS

Cam Follower G With Cage/Stud Head Hex Hole



Stud dia. 6 – 20mm

CF...G

Stud dia. mm	Identification number	Mass (Ref.) (¹) g	Boundary dimensions mm						
			D	C	d ₁	G	G ₁	B _{max}	B _{1max}
6	CF 6 G	19.5	16	11	6	M 6 × 1	8	12.2	28.2
8	CF 8 G	29.5	19	11	8	M 8 × 1.25	10	12.2	32.2
10	CF 10 G	47.5	22	12	10	M10 × 1.25	12	13.2	36.2
	CF 10-1 G	61.5	26	12	10	M10 × 1.25	12	13.2	36.2
12	CF 12 G	95.0	30	14	12	M12 × 1.5	13	15.2	40.2
	CF 12-1 G	105	32	14	12	M12 × 1.5	13	15.2	40.2
16	CF 16 G	175	35	18	16	M16 × 1.5	17	19.6	52.1
18	CF 18 G	255	40	20	18	M18 × 1.5	19	21.6	58.1
20	CF 20 G	470	52	24	20	M20 × 1.5	21	25.6	66.1
	CF 20-1 G	400	47	24	20	M20 × 1.5	21	25.6	66.1

Note⁽¹⁾ This is the value for the product body only. The values for the accessories shown in Table 13 on page I14 are not included.

⁽²⁾ Minimum allowable value of chamfer dimension *r*.

Remarks1. This type of bearings cannot be re-lubricated due to the structure. If the environment requires re-lubrication, please use Standard Type Cam Followers.

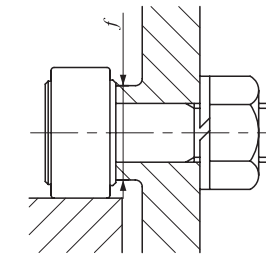
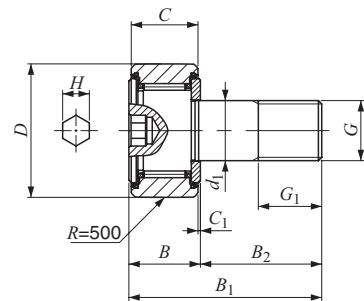
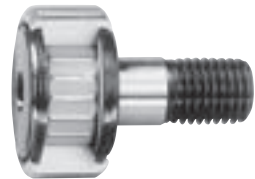
2. Provided with prepacked grease.

B ₂	C ₁	H	r _{s min} ⁽²⁾	Mounting dimension <i>f</i> Min. mm	Maximum tightening torque N-m	Basic dynamic load rating <i>C</i> N	Basic static load rating <i>C</i> ₀ N	Maximum allowable static load N
16	0.6	3	0.3	11	2.7	3 660	3 650	1 950
20	0.6	4	0.3	13	6.5	4 250	4 740	4 620
23	0.6	4	0.3	16	13.8	5 430	6 890	6 890
23	0.6	4	0.3	16	13.8	5 430	6 890	6 890
25	0.6	6	0.6	21	23.9	7 910	9 790	9 790
25	0.6	6	0.6	21	23.9	7 910	9 790	9 790
32.5	0.8	6	0.6	26	61.1	12 000	18 300	18 300
36.5	0.8	8	1	29	89.2	14 800	25 200	25 200
40.5	0.8	8	1	34	125	20 700	34 600	34 600
40.5	0.8	8	1	34	125	20 700	34 600	34 600

I
CF
CFKR
CFS
NUCF
CR

CAM FOLLOWERS

C-Lube Cam Followers **With Cage / Stud Head Hex Hole**



Stud dia. 5 – 20mm

CF...WB.../SG

Stud dia. mm	Identification number	Mass (Ref.) g ⁽¹⁾	Boundary dimensions mm						
			D	C	d ₁	G	G ₁	B	B ₁
5	CF 5 WBUUR/SG	10.3	13	9	5	M 5 × 0.8	7.5	10	23
6	CF 6 WBUUR/SG	18.5	16	11	6	M 6 × 1	8	12.2 max	28.2 max
8	CF 8 WBUUR/SG	28.5	19	11	8	M 8 × 1.25	10	12.2 max	32.2 max
10	CF 10 WBUUR/SG	45	22	12	10	M10 × 1.25	12	13.2 max	36.2 max
	CF 10-1 WBUUR/SG	60	26	12	10	M10 × 1.25	12	13.2 max	36.2 max
12	CF 12 WBUUR/SG	95	30	14	12	M12 × 1.5	13	15.2 max	40.2 max
	CF 12-1 WBUUR/SG	105	32	14	12	M12 × 1.5	13	15.2 max	40.2 max
16	CF 16 WBUUR/SG	170	35	18	16	M16 × 1.5	17	19.6 max	52.1 max
18	CF 18 WBUUR/SG	250	40	20	18	M18 × 1.5	19	21.6 max	58.1 max
20	CF 20 WBUUR/SG	460	52	24	20	M20 × 1.5	21	25.6 max	66.1 max
	CF 20-1 WBUUR/SG	385	47	24	20	M20 × 1.5	21	25.6 max	66.1 max

Note(1) This is the value for the product body only. The values for the accessories shown in Table 13 on page 114 are not included.
 Remark This bearing cannot be re-lubricated as thermosetting solid-type lubricant C-Lube fills its inner space.

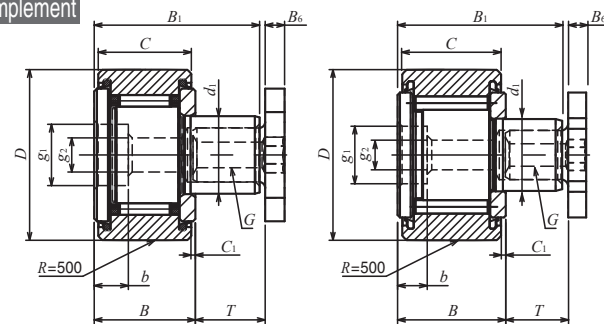
B ₂	C ₁	H	Mounting dimension f Min. mm	Maximum tightening torque N-m	Basic dynamic load rating	Basic static load rating	Maximum allowable static load
					C	C ₀	
13	0.5	3	9.3	1.6	2 520	2 140	1 260
16	0.6	3	11	2.7	3 660	3 650	1 950
20	0.6	4	13	6.5	4 250	4 740	4 620
23	0.6	4	16	13.8	5 430	6 890	6 890
23	0.6	4	16	13.8	5 430	6 890	6 890
25	0.6	6	21	21.9	7 910	9 790	9 790
25	0.6	6	21	21.9	7 910	9 790	9 790
32.5	0.8	6	26	58.5	12 000	18 300	18 300
36.5	0.8	8	29	86.2	14 800	25 200	25 200
40.5	0.8	8	34	119	20 700	34 600	34 600
40.5	0.8	8	34	119	20 700	34 600	34 600

I
CF
CFKR
CFS
NUCF
CR

CAM FOLLOWERS

Short Stud Type Cam Followers CFC...B

With cage
Full complement



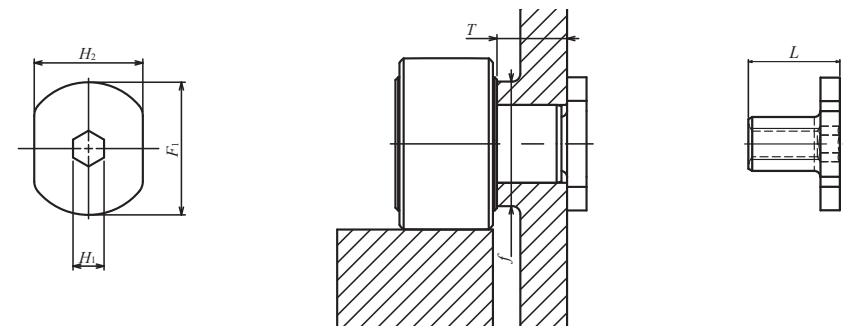
CFC...BUUR

CFC...VBUUR

Stud dia. 8 – 12mm

Stud dia. mm	Identification number		Mass (Ref.) g	Boundary dimensions mm							
	With cage	Full complement		D	C	d ₁	B _{max}	B ₁	C ₁	T ⁽¹⁾	B ₆ max
8	CFC 8 BUUR	—	27	19	11	8	12.2	18.3	0.6	7~11 (13)	2.2
	—	CFC 8 VBUUR	28	19	11	8	12.2	18.3	0.6	7~11 (13)	2.2
10	CFC 10 BUUR	—	42	22	12	10	13.2	21.3	0.6	9~14 (17)	2.7
	—	CFC 10 VBUUR	43	22	12	10	13.2	21.3	0.6	9~14 (17)	2.7
	CFC 10-1 BUUR	—	56	26	12	10	13.2	21.3	0.6	9~14 (17)	2.7
	—	CFC 10-1 VBUUR	57	26	12	10	13.2	21.3	0.6	9~14 (17)	2.7
12	CFC 12 BUUR	—	88	30	14	12	15.2	24.3	0.6	10~15 (19)	3.2
	—	CFC 12 VBUUR	90	30	14	12	15.2	24.3	0.6	10~15 (19)	3.2
	CFC 12-1 BUUR	—	99	32	14	12	15.2	24.3	0.6	10~15 (19)	3.2
	—	CFC 12-1 VBUUR	100	32	14	12	15.2	24.3	0.6	10~15 (19)	3.2

Note⁽¹⁾ This is the mounting range possible with the supplied bolt. Regarding the dimensions in parentheses, the customer should use a separate hexagon socket head bolt (strength division 12.9) referring to Figure 7 on page I18.



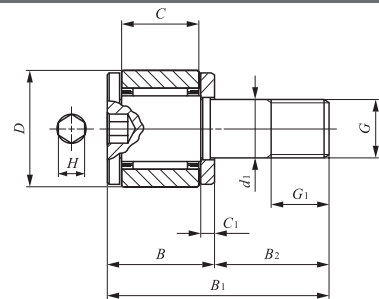
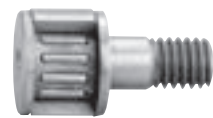
Dedicated flange nut

G	b	g ₁	g ₂	H ₁	H ₂	F ₁	L _{max} mm	Mounting dimension	Maximum tightening torque N·m	Basic dynamic load rating C N	Basic static load rating C ₀ N	Maximum allowable static load N
								f Min. mm				
M3x0.5	3.3	6.4	3.3	3	12	13.9	9.2	13	1.7	4 250	4 740	3 860
M3x0.5	3.3	6.4	3.3	3	12	13.9	9.2	13	1.7	8 170	11 200	3 860
M4x0.7	4.4	7.9	4.4	4	14	17.1	12.0	16	4.0	5 430	6 890	6 890
M4x0.7	4.4	7.9	4.4	4	14	17.1	12.0	16	4.0	9 570	14 500	7 060
M4x0.7	4.4	7.9	4.4	4	14	17.1	12.0	16	4.0	5 430	6 890	6 890
M4x0.7	4.4	7.9	4.4	4	14	17.1	12.0	16	4.0	9 570	14 500	7 060
M5x0.8	5.4	9.4	5.4	5	19	22.4	13.6	21	7.9	7 910	9 790	9 790
M5x0.8	5.4	9.4	5.4	5	19	22.4	13.6	21	7.9	13 500	19 700	11 300
M5x0.8	5.4	9.4	5.4	5	19	22.4	13.6	21	7.9	7 910	9 790	9 790
M5x0.8	5.4	9.4	5.4	5	19	22.4	13.6	21	7.9	13 500	19 700	11 300

I
CF
CFKR
CFS
NUCF
CR

CAM FOLLOWERS

Miniature Type Cam Followers **With Cage/Stud Head Hex Hole**
Full Complement Type/Stud Head Hex Hole

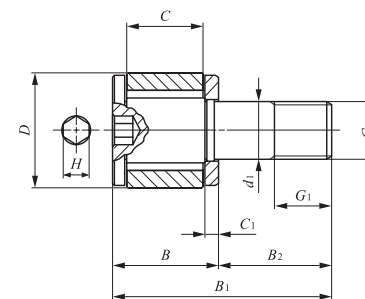


CFS

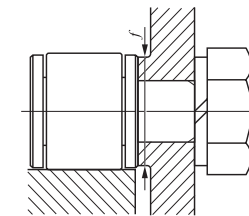
Stud dia. 2 – 6mm

Stud dia. mm	Identification number		Mass (Ref.) g ⁽¹⁾	Boundary dimensions mm					
	With cage	Full complement		D	C	d ₁	G	G ₁	B
2	CFS 2	—	0.6	4.5	2.5	2	M2 × 0.4	2	4
	—	CFS 2 V	0.6	4.5	2.5	2	M2 × 0.4	2	4
2.5	CFS 2.5	—	1	5	3	2.5	M2.5 × 0.45	2.5	4.5
	—	CFS 2.5 V	1	5	3	2.5	M2.5 × 0.45	2.5	4.5
3	CFS 3	—	2	6	4	3	M3 × 0.5	3	5.5
	—	CFS 3 V	2	6	4	3	M3 × 0.5	3	5.5
4	CFS 4	—	4	8	5	4	M4 × 0.7	4	7
	—	CFS 4 V	4	8	5	4	M4 × 0.7	4	7
5	CFS 5	—	7	10	6	5	M5 × 0.8	5	8
	—	CFS 5 V	7	10	6	5	M5 × 0.8	5	8
6	CFS 6	—	13	12	7	6	M6 × 1	6	9.5
	—	CFS 6 V	13	12	7	6	M6 × 1	6	9.5

Note(1) This is the value for the product body only. The values for the accessories shown in Table 13 on page I14 are not included.
 Remarks1. No oil hole is provided.
 2. Provided with prepacked grease.



CFS...V

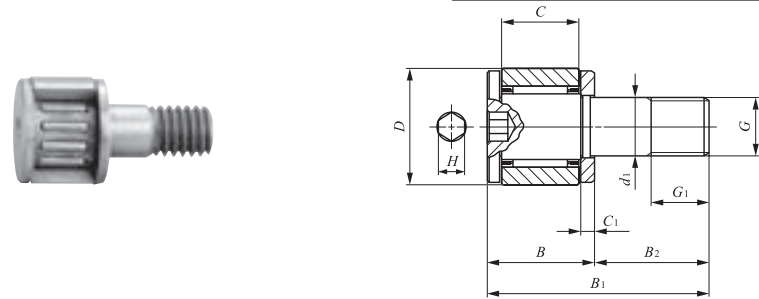


B ₁	B ₂	C ₁	H	Mounting dimension f Min. mm	Maximum tightening torque N-cm	Basic dynamic load rating	Basic static load rating	Maximum allowable static load
						C	C ₀	N
8	4	0.7	0.9	4.3	9.1	288	202	202
8	4	0.7	0.9	4.3	9.1	768	734	229
9.5	5	0.7	0.9	4.8	18.7	428	351	351
9.5	5	0.7	0.9	4.8	18.7	1 000	1 080	360
11.5	6	0.7	1.3	5.8	33.5	629	611	484
11.5	6	0.7	1.3	5.8	33.5	1 420	1 790	484
15	8	1.0	1.5	7.7	77.7	1 120	1 120	919
15	8	1.0	1.5	7.7	77.7	2 370	3 000	919
18	10	1.0	2	9.6	158	1 570	1 850	1 570
18	10	1.0	2	9.6	158	3 180	4 700	1 570
21.5	12	1.2	2.5	11.6	268	2 090	2 200	2 150
21.5	12	1.2	2.5	11.6	268	4 610	6 250	2 150

I
 CF
 CFKR
 CFS
 NUFCF
 CR

CAM FOLLOWERS

Miniature Type Cam Followers / Stainless Steel Made **With Cage/Stud Head Hex Hole**
Full Complement Type/Stud Head Hex Hole

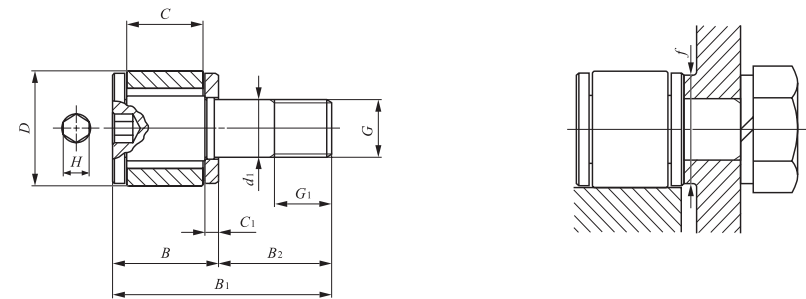


CFS...F

Stud dia. 2 – 6mm

Stud dia. mm	Identification number		Mass (Ref.) g ⁽¹⁾	Boundary dimensions mm					
	With cage	Full complement		D	C	d ₁	G	G ₁	B
2	CFS 2 F	—	0.6	4.5	2.5	2	M2 × 0.4	2	4
	—	CFS 2 FV	0.6	4.5	2.5	2	M2 × 0.4	2	4
2.5	CFS 2.5 F	—	1	5	3	2.5	M2.5 × 0.45	2.5	4.5
	—	CFS 2.5 FV	1	5	3	2.5	M2.5 × 0.45	2.5	4.5
3	CFS 3 F	—	2	6	4	3	M3 × 0.5	3	5.5
	—	CFS 3 FV	2	6	4	3	M3 × 0.5	3	5.5
4	CFS 4 F	—	4	8	5	4	M4 × 0.7	4	7
	—	CFS 4 FV	4	8	5	4	M4 × 0.7	4	7
5	CFS 5 F	—	7	10	6	5	M5 × 0.8	5	8
	—	CFS 5 FV	7	10	6	5	M5 × 0.8	5	8
6	CFS 6 F	—	13	12	7	6	M6 × 1	6	9.5
	—	CFS 6 FV	13	12	7	6	M6 × 1	6	9.5

Note(1) This is the value for the product body only. The values for the accessories shown in Table 13 on page I14 are not included.
 Remarks1. No oil hole is provided.
 2. Provided with prepacked grease.



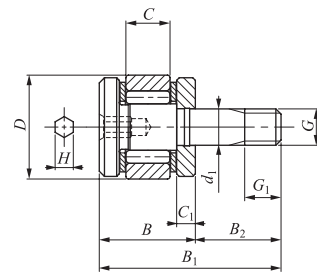
CFS...FV

B ₁	B ₂	C ₁	H	Mounting dimension f Min. mm	Maximum tightening torque N-cm	Basic dynamic load rating	Basic static load rating	Maximum allowable static load
						C	C ₀	N
8	4	0.7	0.9	4.3	9.1	230	161	161
8	4	0.7	0.9	4.3	9.1	614	587	229
9.5	5	0.7	0.9	4.8	18.7	342	281	281
9.5	5	0.7	0.9	4.8	18.7	800	862	360
11.5	6	0.7	1.3	5.8	33.5	504	488	484
11.5	6	0.7	1.3	5.8	33.5	1 140	1 430	484
15	8	1.0	1.5	7.7	77.7	897	894	894
15	8	1.0	1.5	7.7	77.7	1 900	2 400	919
18	10	1.0	2	9.6	158	1 250	1 480	1 480
18	10	1.0	2	9.6	158	2 540	3 760	1 570
21.5	12	1.2	2.5	11.6	268	1 670	1 760	1 760
21.5	12	1.2	2.5	11.6	268	3 690	5 000	2 150

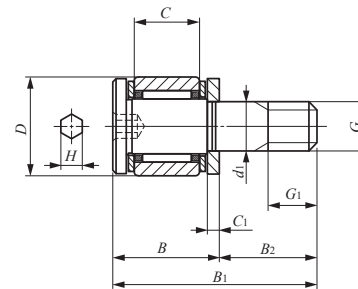
I
 CF
 CFKR
 CFS
 NUFC
 CR

CAM FOLLOWERS

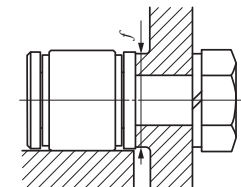
Thrust Disk Type Miniature Cam Followers **With Cage/Stud Head Hex Hole**
Full Complement Type/Stud Head Hex Hole



CFS1.4 WV



CFS... W



Stud dia. 1.4 – 6mm

Stud dia. mm	Identification number		Mass (Ref.) g ⁽¹⁾	Boundary dimensions mm					
	With cage	Full complement		D	C	d ₁	G	G ₁	B
1.4	—	CFS 1.4 WV	0.35	4	1.7	1.4	M1.4 × 0.3	1.4	3.7
2	CFS 2 W	—	0.6	4.5	2.5	2	M2 × 0.4	2	4.5
2.5	CFS 2.5 W	—	1	5	3	2.5	M2.5 × 0.45	2.5	5
3	CFS 3 W	—	2	6	4	3	M3 × 0.5	3	6.5
4	CFS 4 W	—	4	8	5	4	M4 × 0.7	4	8
5	CFS 5 W	—	7	10	6	5	M5 × 0.8	5	9
6	CFS 6 W	—	13	12	7	6	M6 × 1	6	10.5

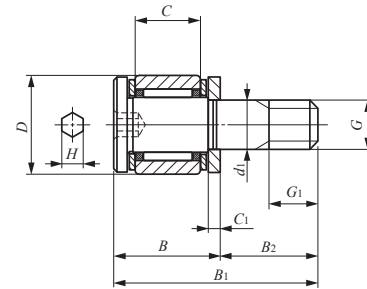
Note⁽¹⁾ This is the value for the product body only. The values for the accessories shown in Table 13 on page I14 are not included.
 Remarks1. No oil hole is provided.
 2. Provided with prepacked grease.

B ₁	B ₂	C ₁	H	Mounting dimension f Min. mm	Maximum tightening torque N-cm	Basic dynamic load rating	Basic static load rating	Maximum allowable static load
						C	C ₀	
7	3.3	0.7	0.9	3.8	3.0	481	385	105
8.5	4	0.7	0.9	4.3	9.1	288	202	194
10	5	0.7	0.9	4.8	18.7	428	351	313
12.5	6	0.7	1.3	5.8	33.5	629	611	399
16	8	1	1.5	7.7	77.7	1120	1120	785
19	10	1	2	9.6	158	1570	1850	1370
22.5	12	1.2	2.5	11.6	268	2090	2200	1920

I
 CF
 CFKR
 CFS
 NUCF
 CR

CAM FOLLOWERS

Thrust Disk Type Miniature Cam Followers · Stainless Steel Made **With Cage/Stud Head Hex Hole**

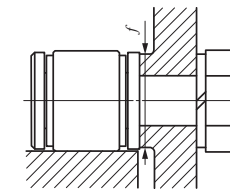


CFS...FW

Stud dia. 2 – 6mm

Stud dia. mm	Identification number	Mass (Ref.) ⁽¹⁾ g	Boundary dimensions mm					
			D	C	d ₁	G	G ₁	B
2	CFS 2 FW	0.6	4.5	2.5	2	M2 × 0.4	2	4.5
2.5	CFS 2.5 FW	1	5	3	2.5	M2.5 × 0.45	2.5	5
3	CFS 3 FW	2	6	4	3	M3 × 0.5	3	6.5
4	CFS 4 FW	4	8	5	4	M4 × 0.7	4	8
5	CFS 5 FW	7	10	6	5	M5 × 0.8	5	9
6	CFS 6 FW	13	12	7	6	M6 × 1	6	10.5

Note(1) This is the value for the product body only. The values for the accessories shown in Table 13 on page I14 are not included.
 Remarks1. No oil hole is provided.
 2. Provided with prepacked grease.

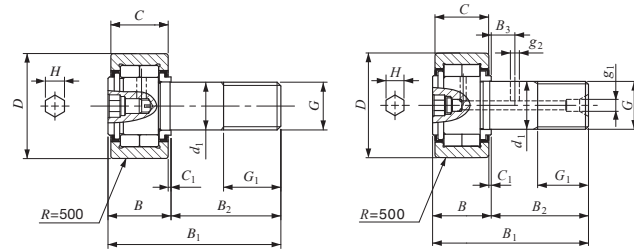
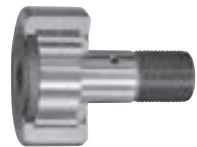


B ₁	B ₂	C ₁	H	Mounting dimension f Min. mm	Maximum tightening torque N-cm	Basic dynamic load rating C N	Basic static load rating C ₀ N	Maximum allowable static load N
8.5	4	0.7	0.9	4.3	9.1	230	161	161
10	5	0.7	0.9	4.8	18.7	342	281	281
12.5	6	0.7	1.3	5.8	33.5	504	488	399
16	8	1.0	1.5	7.7	77.7	897	894	785
19	10	1.0	2	9.6	158	1 250	1 480	1 370
22.5	12	1.2	2.5	11.6	268	1 670	1 760	1 760

I
CF
CFKR
CFS
NUCF
CR

CAM FOLLOWERS

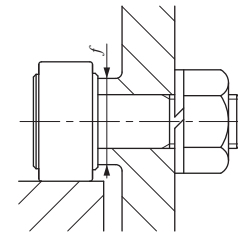
Cylindrical Roller Cam Followers Full Complement Type/Stud Head Hex Hole



NUCF...BR
Stud dia. d_1 10mm

NUCF...BR
Stud dia. d_1 12-30mm

Stud dia. 10—30mm



Stud dia. mm	Identification number	Mass (Ref.) ⁽¹⁾ g	Boundary dimensions mm							
			D	C	d_1	G	G_1	B_{max}	B_{1max}	B_2
10	NUCF 10 BR	44	22	12	10	M10 × 1.25	12	13.2	36.2	23
	NUCF 10-1 BR	58	26	12	10	M10 × 1.25	12	13.2	36.2	23
12	NUCF 12 BR	86	30	14	12	M12 × 1.5	13	15.2	40.2	25
	NUCF 12-1 BR	97	32	14	12	M12 × 1.5	13	15.2	40.2	25
16	NUCF 16 BR	167	35	18	16	M16 × 1.5	17	19.6	52.1	32.5
18	NUCF 18 BR	244	40	20	18	M18 × 1.5	19	21.6	58.1	36.5
20	NUCF 20 BR	457	52	24	20	M20 × 1.5	21	25.6	66.1	40.5
	NUCF 20-1 BR	384	47	24	20	M20 × 1.5	21	25.6	66.1	40.5
24	NUCF 24 BR	789	62	29	24	M24 × 1.5	25	30.6	80.1	49.5
	NUCF 24-1 BR	1 020	72	29	24	M24 × 1.5	25	30.6	80.1	49.5
30	NUCF 30 BR	1 600	80	35	30	M30 × 1.5	32	37	100	63
	NUCF 30-2 BR	1 970	90	35	30	M30 × 1.5	32	37	100	63

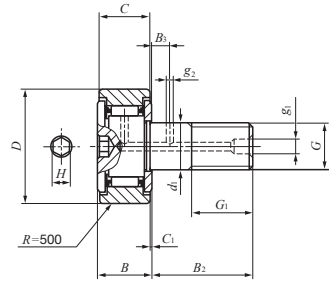
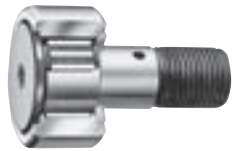
Note⁽¹⁾ This is the value for the product body only. The values for the accessories shown in Table 13 on page I14 are not included.
 Remarks1. For models with a stud diameter d_1 of 10mm, oil hole (re-greasing fitting) is provided at the head. Other models are provided with an oil hole (grease nipple) at the head and an oil hole each on the outside surface and end surface of the stud.
 2. Provided with prepacked grease.

B_3	C_1	g_1	g_2	H	Mounting dimension f Min. mm	Maximum tightening torque N·m	Basic dynamic load rating C N	Basic static load rating C_0 N	Maximum allowable static load N
—	0.6	—	—	4	12	13.8	10 400	11 500	5 300
—	0.6	—	—	4	12	13.8	10 400	11 500	9 210
6	0.6	4	3	6	17	21.9	14 000	13 400	5 650
6	0.6	4	3	6	17	21.9	14 000	13 400	9 040
8	0.8	4	3	6	20	58.5	23 400	27 300	11 800
8	0.8	6	3	8	22	86.2	25 200	30 900	20 300
9	0.8	6	4	8	31	119	43 100	58 100	30 000
9	0.8	6	4	8	27	119	38 900	49 000	27 200
11	0.8	6	4	12	38	215	58 200	75 300	35 200
11	0.8	6	4	12	44	215	63 900	88 800	57 000
15	1	6	4	17	45	438	90 300	121 000	98 300
15	1	6	4	17	45	438	90 300	121 000	98 300

I
CF
CFKR
CFS
NUCF
CR

CAM FOLLOWERS

Inch Series Cam Followers With Cage/Stud Head Hex Hole



Stud dia. 4.826 – 22.225mm

CR...BR

Stud dia. mm (inch)	Identification number				Mass (Ref.) g ⁽²⁾	D	C	d ₁	G UNF	G ₁
	Shield type		Sealed type							
	With crowned outer ring	With cylindrical outer ring	With crowned outer ring	With cylindrical outer ring						
4.826	CR 8 BR	CR 8 B	CR 8 BUUR	CR 8 BUU	9	12.700 (1/2)	8.731 (11/32)	4.826	No.10-32	6.350 (1/4)
	CR 8-1 BR	CR 8-1 B	CR 8-1 BUUR	CR 8-1 BUU	10	12.700 (1/2)	9.525 (3/8)	4.826	No.10-32	6.350 (1/4)
6.350 (1/4)	CR 10 BR	CR 10 B	CR 10 BUUR	CR 10 BUU	19	15.875 (5/8)	10.319 (13/32)	6.350 (1/4)	1/4-28	7.938 (5/16)
	CR 10-1 BR	CR 10-1 B	CR 10-1 BUUR	CR 10-1 BUU	21	15.875 (5/8)	11.112 (7/16)	6.350 (1/4)	1/4-28	7.938 (5/16)
9.525 (3/8)	CR 12 BR	CR 12 B	CR 12 BUUR	CR 12 BUU	35	19.050 (3/4)	12.700 (1/2)	9.525 (3/8)	3/8-24	9.525 (3/8)
	CR 14 BR	CR 14 B	CR 14 BUUR	CR 14 BUU	46	22.225 (7/8)	12.700 (1/2)	9.525 (3/8)	3/8-24	9.525 (3/8)
11.112 (7/16)	CR 16 BR	CR 16 B	CR 16 BUUR	CR 16 BUU	73	25.400 (1)	15.875 (5/8)	11.112 (7/16)	7/16-20	12.700 (1/2)
	CR 18 BR	CR 18 B	CR 18 BUUR	CR 18 BUU	99	28.575 (1 1/8)	15.875 (5/8)	11.112 (7/16)	7/16-20	12.700 (1/2)
12.700 (1/2)	CR 20 BR	CR 20 B	CR 20 BUUR	CR 20 BUU	132	31.750 (1 1/4)	19.050 (3/4)	12.700 (1/2)	1/2-20	15.875 (5/8)
	CR 22 BR	CR 22 B	CR 22 BUUR	CR 22 BUU	157	34.925 (1 3/8)	19.050 (3/4)	12.700 (1/2)	1/2-20	15.875 (5/8)
15.875 (5/8)	CR 24 BR	CR 24 B	CR 24 BUUR	CR 24 BUU	225	38.100 (1 1/2)	22.225 (7/8)	15.875 (5/8)	5/8-18	19.050 (3/4)
	CR 26 BR	CR 26 B	CR 26 BUUR	CR 26 BUU	260	41.275 (1 5/8)	22.225 (7/8)	15.875 (5/8)	5/8-18	19.050 (3/4)
19.050 (3/4)	CR 28 BR	CR 28 B	CR 28 BUUR	CR 28 BUU	365	44.450 (1 3/4)	25.400 (1)	19.050 (3/4)	3/4-16	22.225 (7/8)
	CR 30 BR	CR 30 B	CR 30 BUUR	CR 30 BUU	410	47.625 (1 7/8)	25.400 (1)	19.050 (3/4)	3/4-16	22.225 (7/8)
22.225 (7/8)	CR 32 BR	CR 32 B	CR 32 BUUR	CR 32 BUU	615	50.800 (2)	31.750 (1 1/4)	22.225 (7/8)	7/8-14	25.400 (1)
	CR 36 BR	CR 36 B	CR 36 BUUR	CR 36 BUU	750	57.150 (2 1/4)	31.750 (1 1/4)	22.225 (7/8)	7/8-14	25.400 (1)

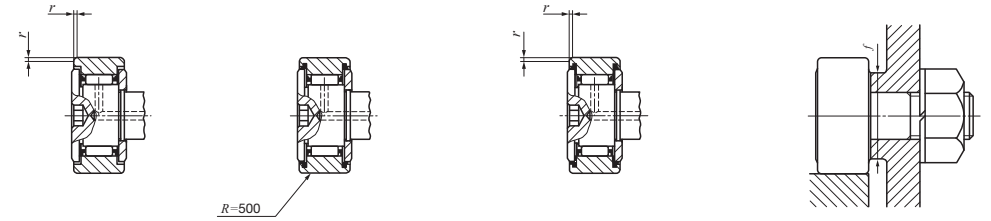
Note(1) For dimensions other than the chamfer dimension (r) and the shape of the outside surface of the outer ring outside surface, refer to the CR...BR drawing.

(2) This is the value for the product body only. The values for the accessories shown in Table 13 on page I14 are not included.

Remarks1. Models with a stud diameter d₁ of 6.35 mm or less have no oil hole. Other models are provided with one oil hole each on the outside surface and end surface of the stud.

2. Provided with prepacked grease.

3. For the maximum allowable static load, please contact IKO.



CR...B(1)

CR...BUUR(1)

CR...BUU(1)

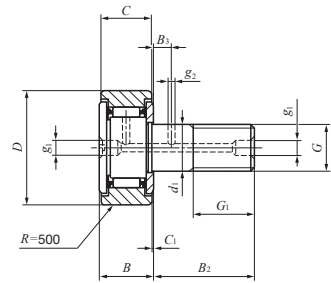
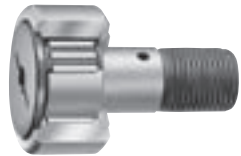
Boundary dimensions mm(inch)								Mounting dimension f Min. mm(inch)	Maximum tightening torque N-m	Basic dynamic load rating C N	Basic static load rating C ₀ N
B max	B ₂	B ₃	C ₁	g ₁	g ₂	H	r				
10.2 (0.40)	12.700 (1/2)	— (—)	0.794 (1/32)	— (—)	— (—)	3.175 (1/8)	0.397 (1/64)	8.334 (21/64)	1.4	2 520	2 140
10.9 (0.43)	15.875 (5/8)	— (—)	0.794 (1/32)	— (—)	— (—)	3.175 (1/8)	0.397 (1/64)	8.334 (21/64)	1.4	2 520	2 140
11.8 (0.46)	15.875 (5/8)	— (—)	0.794 (1/32)	— (—)	— (—)	3.175 (1/8)	0.397 (1/64)	11.509 (29/64)	3.4	3 650	3 670
12.5 (0.49)	19.050 (3/4)	— (—)	0.794 (1/32)	— (—)	— (—)	3.175 (1/8)	0.397 (1/64)	11.509 (29/64)	3.4	3 650	3 670
14.2 (0.56)	22.225 (7/8)	6.350 (1/4)	0.794 (1/32)	4.762 (3/16)	2.381 (3/32)	4.762 (3/16)	0.794 (1/32)	13.494 (17/32)	10.8	4 420	5 110
14.2 (0.56)	22.225 (7/8)	6.350 (1/4)	0.794 (1/32)	4.762 (3/16)	2.381 (3/32)	4.762 (3/16)	0.794 (1/32)	15.081 (19/32)	10.8	4 790	5 810
17.3 (0.68)	25.400 (1)	6.350 (1/4)	0.794 (1/32)	4.762 (3/16)	3.175 (1/8)	6.350 (1/4)	1.191 (3/64)	17.859 (45/64)	17.4	8 810	10 800
17.3 (0.68)	25.400 (1)	6.350 (1/4)	0.794 (1/32)	4.762 (3/16)	3.175 (1/8)	6.350 (1/4)	1.588 (1/16)	19.050 (3/4)	17.4	9 180	11 600
20.4 (0.80)	31.750 (1 1/4)	7.938 (5/16)	0.794 (1/32)	4.762 (3/16)	3.175 (1/8)	6.350 (1/4)	1.588 (1/16)	21.828 (55/64)	27.7	14 200	16 000
20.4 (0.80)	31.750 (1 1/4)	7.938 (5/16)	0.794 (1/32)	4.762 (3/16)	3.175 (1/8)	6.350 (1/4)	1.588 (1/16)	21.828 (55/64)	27.7	14 200	16 000
23.6 (0.93)	38.100 (1 1/2)	9.525 (3/8)	0.794 (1/32)	4.762 (3/16)	3.969 (5/32)	7.938 (5/16)	1.588 (1/16)	26.196 (13/64)	55.7	18 600	24 300
23.6 (0.93)	38.100 (1 1/2)	9.525 (3/8)	0.794 (1/32)	4.762 (3/16)	3.969 (5/32)	7.938 (5/16)	1.588 (1/16)	26.196 (13/64)	55.7	18 600	24 300
26.8 (1.06)	44.450 (1 3/4)	11.112 (7/16)	0.794 (1/32)	4.762 (3/16)	3.969 (5/32)	7.938 (5/16)	1.588 (1/16)	32.543 (19/32)	100	25 100	38 200
26.8 (1.06)	44.450 (1 3/4)	11.112 (7/16)	0.794 (1/32)	4.762 (3/16)	3.969 (5/32)	7.938 (5/16)	1.588 (1/16)	32.543 (19/32)	100	25 100	38 200
33.5 (1.32)	50.800 (2)	12.700 (1/2)	0.794 (1/32)	4.762 (3/16)	4.762 (3/16)	11.112 (7/16)	1.588 (1/16)	37.306 (15/32)	162	32 500	63 900
33.5 (1.32)	50.800 (2)	12.700 (1/2)	0.794 (1/32)	4.762 (3/16)	4.762 (3/16)	11.112 (7/16)	1.588 (1/16)	37.306 (15/32)	162	32 500	63 900

I

CF
CFKR
CFS
NUCF
CR

CAM FOLLOWERS

Inch Series Cam Followers With Cage/With Screwdriver Slot



CR...R

Stud dia. 4.826 – 22.225mm

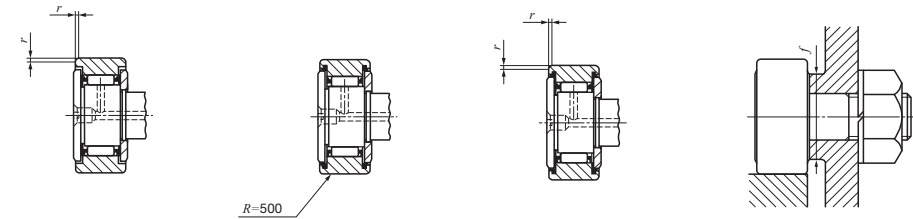
Stud dia. mm (inch)	Identification number				Mass (Ref.) g ⁽²⁾	D	C	d ₁	G UNF	G ₁
	Shield type		Sealed type							
	With crowned outer ring	With cylindrical outer ring	With crowned outer ring	With cylindrical outer ring						
4.826	CR 8 R	CR 8	CR 8 UUR	CR 8 UU	9	12.700 (1/2)	8.731 (11/32)	4.826	No.10-32	6.350 (1/4)
	CR 8-1 R	CR 8-1	CR 8-1 UUR	CR 8-1 UU	10	12.700 (1/2)	9.525 (3/8)	4.826	No.10-32	6.350 (1/4)
6.350 (1/4)	CR 10 R	CR 10	CR 10 UUR	CR 10 UU	19	15.875 (5/8)	10.319 (13/32)	6.350 (1/4)	1/4-28	7.938 (5/16)
	CR 10-1 R	CR 10-1	CR 10-1 UUR	CR 10-1 UU	21	15.875 (5/8)	11.112 (7/16)	6.350 (1/4)	1/4-28	7.938 (5/16)
9.525 (3/8)	CR 12 R	CR 12	CR 12 UUR	CR 12 UU	35	19.050 (3/4)	12.700 (1/2)	9.525 (3/8)	3/8-24	9.525 (3/8)
	CR 14 R	CR 14	CR 14 UUR	CR 14 UU	46	22.225 (7/8)	12.700 (1/2)	9.525 (3/8)	3/8-24	9.525 (3/8)
11.112 (7/16)	CR 16 R	CR 16	CR 16 UUR	CR 16 UU	73	25.400 (1)	15.875 (5/8)	11.112 (7/16)	7/16-20	12.700 (1/2)
	CR 18 R	CR 18	CR 18 UUR	CR 18 UU	99	28.575 (1 1/8)	15.875 (5/8)	11.112 (7/16)	7/16-20	12.700 (1/2)
12.700 (1/2)	CR 20 R	CR 20	CR 20 UUR	CR 20 UU	132	31.750 (1 1/4)	19.050 (3/4)	12.700 (1/2)	1/2-20	15.875 (5/8)
	CR 22 R	CR 22	CR 22 UUR	CR 22 UU	157	34.925 (1 3/8)	19.050 (3/4)	12.700 (1/2)	1/2-20	15.875 (5/8)
15.875 (5/8)	CR 24 R	CR 24	CR 24 UUR	CR 24 UU	225	38.100 (1 1/2)	22.225 (7/8)	15.875 (5/8)	5/8-18	19.050 (3/4)
	CR 26 R	CR 26	CR 26 UUR	CR 26 UU	260	41.275 (1 5/8)	22.225 (7/8)	15.875 (5/8)	5/8-18	19.050 (3/4)
19.050 (3/4)	CR 28 R	CR 28	CR 28 UUR	CR 28 UU	365	44.450 (1 3/4)	25.400 (1)	19.050 (3/4)	3/4-16	22.225 (7/8)
	CR 30 R	CR 30	CR 30 UUR	CR 30 UU	410	47.625 (1 7/8)	25.400 (1)	19.050 (3/4)	3/4-16	22.225 (7/8)
22.225 (7/8)	CR 32 R	CR 32	CR 32 UUR	CR 32 UU	615	50.800 (2)	31.750 (1 1/4)	22.225 (7/8)	7/8-14	25.400 (1)
	CR 36 R	CR 36	CR 36 UUR	CR 36 UU	750	57.150 (2 1/4)	31.750 (1 1/4)	22.225 (7/8)	7/8-14	25.400 (1)

Note⁽¹⁾ For dimensions other than the chamfer dimension (r) and the shape of the outside surface of the outer ring outside surface, refer to the CR...R drawing.

⁽²⁾ This is the value for the product body only. The values for the accessories shown in Table 13 on page I14 are not included.

Remarks1. Models with a stud diameter d₁ of 6.35 mm or less (marked *) are provided with an oil hole on the stud head only. Other models are provided with one oil hole each on the head, outside surface and end surface of the stud.

- 2. Provided with prepacked grease.
- 3. For the maximum allowable static load, please contact IKO.



CR⁽¹⁾

CR...UUR⁽¹⁾

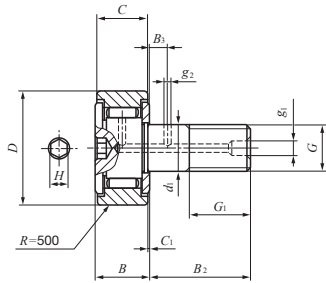
CR...UU⁽¹⁾

Boundary dimensions mm(inch)							Mounting dimension f Min. mm(inch)	Maximum tightening torque N-m	Basic dynamic load rating C N	Basic static load rating C ₀ N
B max	B ₂	B ₃	C ₁	g ₁	g ₂	r				
10.2 (0.40)	12.700 (1/2)	— (—)	0.794 (1/32)	*3.175 (1/8)	— (—)	0.397 (1/64)	8.334 (21/64)	1.4	2 520	2 140
10.9 (0.43)	15.875 (5/8)	— (—)	0.794 (1/32)	*3.175 (1/8)	— (—)	0.397 (1/64)	8.334 (21/64)	1.4	2 520	2 140
11.8 (0.46)	15.875 (5/8)	— (—)	0.794 (1/32)	*3.175 (1/8)	— (—)	0.397 (1/64)	11.509 (29/64)	3.4	3 650	3 670
12.5 (0.49)	19.050 (3/4)	— (—)	0.794 (1/32)	*3.175 (1/8)	— (—)	0.397 (1/64)	11.509 (29/64)	3.4	3 650	3 670
14.2 (0.56)	22.225 (7/8)	6.350 (1/4)	0.794 (1/32)	4.762 (3/16)	2.381 (3/32)	0.794 (1/32)	13.494 (17/32)	10.8	4 420	5 110
14.2 (0.56)	22.225 (7/8)	6.350 (1/4)	0.794 (1/32)	4.762 (3/16)	2.381 (3/32)	0.794 (1/32)	15.081 (19/32)	10.8	4 790	5 810
17.3 (0.68)	25.400 (1)	6.350 (1/4)	0.794 (1/32)	4.762 (3/16)	3.175 (1/8)	1.191 (3/64)	17.859 (45/64)	17.4	8 810	10 800
17.3 (0.68)	25.400 (1)	6.350 (1/4)	0.794 (1/32)	4.762 (3/16)	3.175 (1/8)	1.588 (1/16)	19.050 (3/4)	17.4	9 180	11 600
20.4 (0.80)	31.750 (1 1/4)	7.938 (5/16)	0.794 (1/32)	4.762 (3/16)	3.175 (1/8)	1.588 (1/16)	21.828 (55/64)	27.7	14 200	16 000
20.4 (0.80)	31.750 (1 1/4)	7.938 (5/16)	0.794 (1/32)	4.762 (3/16)	3.175 (1/8)	1.588 (1/16)	21.828 (55/64)	27.7	14 200	16 000
23.6 (0.93)	38.100 (1 1/2)	9.525 (3/8)	0.794 (1/32)	4.762 (3/16)	3.969 (5/32)	1.588 (1/16)	26.196 (1 3/64)	55.7	18 600	24 300
23.6 (0.93)	38.100 (1 1/2)	9.525 (3/8)	0.794 (1/32)	4.762 (3/16)	3.969 (5/32)	1.588 (1/16)	26.196 (1 3/64)	55.7	18 600	24 300
26.8 (1.06)	44.450 (1 3/4)	11.112 (7/16)	0.794 (1/32)	4.762 (3/16)	3.969 (5/32)	1.588 (1/16)	32.543 (1 9/32)	100	25 100	38 200
26.8 (1.06)	44.450 (1 3/4)	11.112 (7/16)	0.794 (1/32)	4.762 (3/16)	3.969 (5/32)	1.588 (1/16)	32.543 (1 9/32)	100	25 100	38 200
33.5 (1.32)	50.800 (2)	12.700 (1/2)	0.794 (1/32)	4.762 (3/16)	4.762 (3/16)	1.588 (1/16)	37.306 (1 15/32)	162	32 500	63 900
33.5 (1.32)	50.800 (2)	12.700 (1/2)	0.794 (1/32)	4.762 (3/16)	4.762 (3/16)	1.588 (1/16)	37.306 (1 15/32)	162	32 500	63 900

I
CF
CFKR
CFS
NUCF
CR

CAM FOLLOWERS

Inch Series Cam Followers Full Complement Type/Stud Head Hex Hole



CR...VBR

Stud dia. 4.826 – 22.225mm

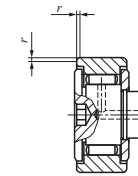
Stud dia. mm (inch)	Identification number				Mass (Ref.) g ⁽²⁾	D	C	d ₁	G UNF	G ₁
	Shield type		Sealed type							
	With crowned outer ring	With cylindrical outer ring	With crowned outer ring	With cylindrical outer ring						
4.826	CR 8 VBR	CR 8 VB	CR 8 VBUUR	CR 8 VBUU	9	12.700 (1/2)	8.731 (11/32)	4.826	No.10-32	6.350 (1/4)
	CR 8-1 VBR	CR 8-1VB	CR 8-1 VBUUR	CR 8-1 VBUU	10	12.700 (1/2)	9.525 (3/8)	4.826	No.10-32	6.350 (1/4)
6.350 (1/4)	CR 10 VBR	CR 10 VB	CR 10 VBUUR	CR 10 VBUU	19	15.875 (5/8)	10.319 (13/32)	6.350 (1/4)	1/4-28	7.938 (5/16)
	CR 10-1 VBR	CR 10-1VB	CR 10-1 VBUUR	CR 10-1 VBUU	21	15.875 (5/8)	11.112 (7/16)	6.350 (1/4)	1/4-28	7.938 (5/16)
9.525 (3/8)	CR 12 VBR	CR 12 VB	CR 12 VBUUR	CR 12 VBUU	36	19.050 (3/4)	12.700 (1/2)	9.525 (3/8)	3/8-24	9.525 (3/8)
	CR 14 VBR	CR 14 VB	CR 14 VBUUR	CR 14 VBUU	47	22.225 (7/8)	12.700 (1/2)	9.525 (3/8)	3/8-24	9.525 (3/8)
11.112 (7/16)	CR 16 VBR	CR 16 VB	CR 16 VBUUR	CR 16 VBUU	74	25.400 (1)	15.875 (5/8)	11.112 (7/16)	7/16-20	12.700 (1/2)
	CR 18 VBR	CR 18 VB	CR 18 VBUUR	CR 18 VBUU	101	28.575 (1 1/8)	15.875 (5/8)	11.112 (7/16)	7/16-20	12.700 (1/2)
12.700 (1/2)	CR 20 VBR	CR 20 VB	CR 20 VBUUR	CR 20 VBUU	137	31.750 (1 1/4)	19.050 (3/4)	12.700 (1/2)	1/2-20	15.875 (5/8)
	CR 22 VBR	CR 22 VB	CR 22 VBUUR	CR 22 VBUU	160	34.925 (1 3/8)	19.050 (3/4)	12.700 (1/2)	1/2-20	15.875 (5/8)
15.875 (5/8)	CR 24 VBR	CR 24 VB	CR 24 VBUUR	CR 24 VBUU	230	38.100 (1 1/2)	22.225 (7/8)	15.875 (5/8)	5/8-18	19.050 (3/4)
	CR 26 VBR	CR 26 VB	CR 26 VBUUR	CR 26 VBUU	265	41.275 (1 5/8)	22.225 (7/8)	15.875 (5/8)	5/8-18	19.050 (3/4)
19.050 (3/4)	CR 28 VBR	CR 28 VB	CR 28 VBUUR	CR 28 VBUU	372	44.450 (1 3/4)	25.400 (1)	19.050 (3/4)	3/4-16	22.225 (7/8)
	CR 30 VBR	CR 30 VB	CR 30 VBUUR	CR 30 VBUU	418	47.625 (1 7/8)	25.400 (1)	19.050 (3/4)	3/4-16	22.225 (7/8)
22.225 (7/8)	CR 32 VBR	CR 32 VB	CR 32 VBUUR	CR 32 VBUU	627	50.800 (2)	31.750 (1 1/4)	22.225 (7/8)	7/8-14	25.400 (1)
	CR 36 VBR	CR 36 VB	CR 36 VBUUR	CR 36 VBUU	759	57.150 (2 1/4)	31.750 (1 1/4)	22.225 (7/8)	7/8-14	25.400 (1)

Note(1) For dimensions other than the chamfer dimension (r) and the shape of the outside surface of the outer ring outside surface, refer to the CR...VBR drawing.

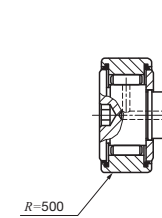
(2) This is the value for the product body only. The values for the accessories shown in Table 13 on page I14 are not included.

Remarks1. Models with a stud diameter d₁ of 6.35 mm or less have no oil hole. Other models are provided with one oil hole each on the outside surface and end surface of the stud.

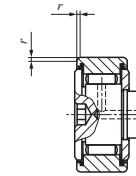
- 2. Provided with prepacked grease.
- 3. For the maximum allowable static load, please contact IKO.



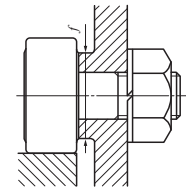
CR...VB⁽¹⁾



CR...VBUUR⁽¹⁾



CR...VBUU⁽¹⁾

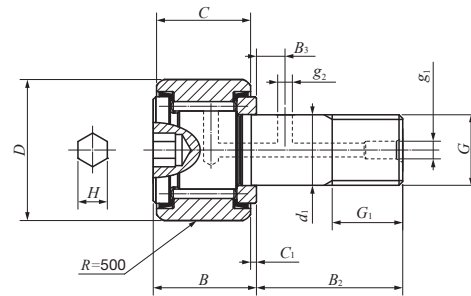


Boundary dimensions mm(inch)								Mounting dimension f Min. mm(inch)	Maximum tightening torque N-m	Basic dynamic load rating C N	Basic static load rating C ₀ N
B max	B ₂	B ₃	C ₁	g ₁	g ₂	H	r				
10.2 (0.40)	12.700 (1/2)	— (—)	0.794 (1/32)	— (—)	— (—)	3.175 (1/8)	0.397 (1/64)	8.334 (21/64)	1.4	4 260	4 750
10.9 (0.43)	15.875 (5/8)	— (—)	0.794 (1/32)	— (—)	— (—)	3.175 (1/8)	0.397 (1/64)	8.334 (21/64)	1.4	4 710	5 410
11.8 (0.46)	15.875 (5/8)	— (—)	0.794 (1/32)	— (—)	— (—)	3.175 (1/8)	0.397 (1/64)	11.509 (29/64)	3.4	5 830	7 660
12.5 (0.49)	19.050 (3/4)	— (—)	0.794 (1/32)	— (—)	— (—)	3.175 (1/8)	0.397 (1/64)	11.509 (29/64)	3.4	6 340	8 530
14.2 (0.56)	22.225 (7/8)	6.350 (1/4)	0.794 (1/32)	4.762 (3/16)	2.381 (3/32)	4.762 (3/16)	0.794 (1/32)	13.494 (17/32)	10.8	8 710	12 300
14.2 (0.56)	22.225 (7/8)	6.350 (1/4)	0.794 (1/32)	4.762 (3/16)	2.381 (3/32)	4.762 (3/16)	0.794 (1/32)	15.081 (19/32)	10.8	8 710	12 300
17.3 (0.68)	25.400 (1)	6.350 (1/4)	0.794 (1/32)	4.762 (3/16)	3.175 (1/8)	6.350 (1/4)	1.191 (3/64)	17.859 (45/64)	17.4	13 100	22 700
17.3 (0.68)	25.400 (1)	6.350 (1/4)	0.794 (1/32)	4.762 (3/16)	3.175 (1/8)	6.350 (1/4)	1.588 (1/16)	19.050 (3/4)	17.4	13 100	22 700
20.4 (0.80)	31.750 (1 1/4)	7.938 (5/16)	0.794 (1/32)	4.762 (3/16)	3.175 (1/8)	6.350 (1/4)	1.588 (1/16)	21.828 (55/64)	27.7	23 600	31 700
20.4 (0.80)	31.750 (1 1/4)	7.938 (5/16)	0.794 (1/32)	4.762 (3/16)	3.175 (1/8)	6.350 (1/4)	1.588 (1/16)	21.828 (55/64)	27.7	23 600	31 700
23.6 (0.93)	38.100 (1 1/2)	9.525 (3/8)	0.794 (1/32)	4.762 (3/16)	3.969 (5/32)	7.938 (5/16)	1.588 (1/16)	26.196 (1 3/64)	55.7	28 200	40 100
23.6 (0.93)	38.100 (1 1/2)	9.525 (3/8)	0.794 (1/32)	4.762 (3/16)	3.969 (5/32)	7.938 (5/16)	1.588 (1/16)	26.196 (1 3/64)	55.7	28 200	40 100
26.8 (1.06)	44.450 (1 3/4)	11.112 (7/16)	0.794 (1/32)	4.762 (3/16)	3.969 (5/32)	7.938 (5/16)	1.588 (1/16)	32.543 (1 9/32)	100	35 300	55 600
26.8 (1.06)	44.450 (1 3/4)	11.112 (7/16)	0.794 (1/32)	4.762 (3/16)	3.969 (5/32)	7.938 (5/16)	1.588 (1/16)	32.543 (1 9/32)	100	35 300	55 600
33.5 (1.32)	50.800 (2)	12.700 (1/2)	0.794 (1/32)	4.762 (3/16)	4.762 (3/16)	11.112 (7/16)	1.588 (1/16)	37.306 (1 15/32)	162	45 700	80 600
33.5 (1.32)	50.800 (2)	12.700 (1/2)	0.794 (1/32)	4.762 (3/16)	4.762 (3/16)	11.112 (7/16)	1.588 (1/16)	37.306 (1 15/32)	162	45 700	80 600

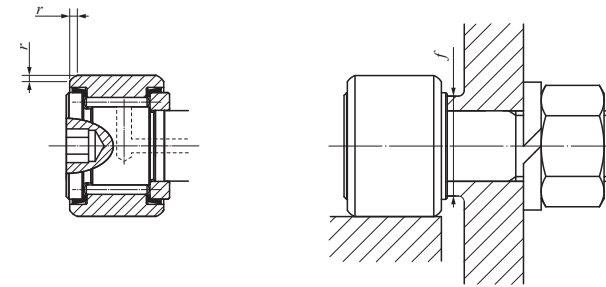
I
CF
CFKR
CFS
NUCF
CR

CAM FOLLOWERS

Inch Series Cam Followers Full Complement Type/Stud Head Hex Hole



CR...VBSR



CR...VBS(1)

Stud dia. 4.826 – 22.225mm

Stud dia. mm (inch)	Identification number		Mass (Ref.) g ⁽²⁾	Boundary dimensions mm (inch)						
	Sealed type with ThrustDisk Seals™			D	C	d ₁	G UNF	G ₁	B max	B ₂
	With crowned outer ring	With cylindrical outer ring								
4.826	CR 8 VBSR	CR 8 VBS	9	12.700 (1/2)	8.731 (11/32)	4.826	No.10-32	6.350 (1/4)	10.2(0.40)	12.700 (1/2)
	CR 8-1 VBSR	CR 8-1 VBS	10	12.700 (1/2)	9.525 (3/8)	4.826	No.10-32	6.350 (1/4)	10.9(0.43)	15.875 (5/8)
6.350 (1/4)	CR 10 VBSR	CR 10 VBS	19	15.875 (5/8)	10.319 (13/32)	6.350 (1/4)	1/4-28	7.938 (5/16)	11.8(0.46)	15.875 (5/8)
	CR 10-1 VBSR	CR 10-1 VBS	21	15.875 (5/8)	11.112 (7/16)	6.350 (1/4)	1/4-28	7.938 (5/16)	12.5(0.49)	19.050 (3/4)
9.525 (3/8)	CR 12 VBSR	CR 12 VBS	34	19.050 (3/4)	12.700 (1/2)	9.525 (3/8)	5/8-24	9.525 (3/8)	14.2(0.56)	22.225 (7/8)
	CR 14 VBSR	CR 14 VBS	45	22.225 (7/8)	12.700 (1/2)	9.525 (3/8)	5/8-24	9.525 (3/8)	14.2(0.56)	22.225 (7/8)
11.112 (7/16)	CR 16 VBSR	CR 16 VBS	73	25.400 (1)	15.875 (5/8)	11.112 (7/16)	7/16-20	12.700 (1/2)	17.3(0.68)	25.400 (1)
	CR 18 VBSR	CR 18 VBS	100	28.575 (1 1/8)	15.875 (5/8)	11.112 (7/16)	7/16-20	12.700 (1/2)	17.3(0.68)	25.400 (1)
12.700 (1/2)	CR 20 VBSR	CR 20 VBS	136	31.750 (1 1/4)	19.050 (3/4)	12.700 (1/2)	1/2-20	15.875 (5/8)	20.4(0.80)	31.750 (1 1/4)
	CR 22 VBSR	CR 22 VBS	159	34.925 (1 3/8)	19.050 (3/4)	12.700 (1/2)	1/2-20	15.875 (5/8)	20.4(0.80)	31.750 (1 1/4)
15.875 (5/8)	CR 24 VBSR	CR 24 VBS	230	38.100 (1 1/2)	22.225 (7/8)	15.875 (5/8)	3/8-18	19.050 (3/4)	23.6(0.93)	38.100 (1 1/2)
	CR 26 VBSR	CR 26 VBS	265	41.275 (1 5/8)	22.225 (7/8)	15.875 (5/8)	3/8-18	19.050 (3/4)	23.6(0.93)	38.100 (1 1/2)
19.050 (3/4)	CR 28 VBSR	CR 28 VBS	368	44.450 (1 3/4)	25.400 (1)	19.050 (3/4)	1/2-16	22.225 (7/8)	26.8(1.06)	44.450 (1 3/4)
	CR 30 VBSR	CR 30 VBS	413	47.625 (1 7/8)	25.400 (1)	19.050 (3/4)	1/2-16	22.225 (7/8)	26.8(1.06)	44.450 (1 3/4)
22.225 (7/8)	CR 32 VBSR	CR 32 VBS	620	50.800 (2)	31.750 (1 1/4)	22.225 (7/8)	5/8-14	25.400 (1)	33.5(1.32)	50.800 (2)
	CR 36 VBSR	CR 36 VBS	753	57.150 (2 1/4)	31.750 (1 1/4)	22.225 (7/8)	5/8-14	25.400 (1)	33.5(1.32)	50.800 (2)

Note(1) For dimensions other than the chamfer dimension (r) and the shape of the outside surface of the outer ring outside surface, refer to the CR...VBSR drawing.

(2) This is the value for the product body only. The values for the accessories shown in Table 13 on page I14 are not included.
Remarks1. Models with a stud diameter d₁ of 6.35 mm or less have no oil hole. Other models are provided with one oil hole each on the outside surface and end surface of the stud.

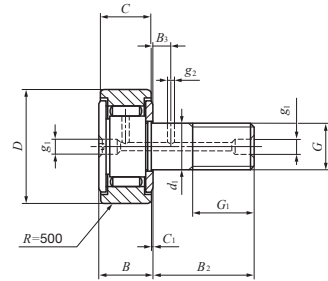
2. Provided with prepacked grease.
3. For the maximum allowable static load, please contact IKO.
4. If you require a specification with cage or with cage + C-Lube, please contact IKO for more information.

Boundary dimensions mm (inch)						Mounting dimension f Min. mm (inch)	Maximum tightening torque N-m	Basic dynamic load rating C N	Basic static load rating C ₀ N
B ₃	C ₁	g ₁	g ₂	H	r				
— (—)	0.794 (1/32)	— (—)	— (—)	3.175 (1/8)	0.397 (1/64)	8.334 (21/64)	1.4	3 790	4 100
— (—)	0.794 (1/32)	— (—)	— (—)	3.175 (1/8)	0.397 (1/64)	8.334 (21/64)	1.4	4 260	4 750
— (—)	0.794 (1/32)	— (—)	— (—)	3.175 (1/8)	0.397 (1/64)	11.509 (29/64)	3.4	5 310	6 780
— (—)	0.794 (1/32)	— (—)	— (—)	3.175 (1/8)	0.397 (1/64)	11.509 (29/64)	3.4	5 830	7 660
6.350 (1/4)	0.794 (1/32)	4.762 (3/16)	2.381 (3/32)	4.762 (3/16)	0.794 (1/32)	13.494 (17/32)	10.8	7 400	11 100
6.350 (1/4)	0.794 (1/32)	4.762 (3/16)	2.381 (3/32)	4.762 (3/16)	0.794 (1/32)	15.081 (19/32)	10.8	7 400	11 100
6.350 (1/4)	0.794 (1/32)	4.762 (3/16)	3.175 (1/8)	6.350 (1/4)	1.191 (3/64)	17.859 (45/64)	17.4	12,000	20,300
6.350 (1/4)	0.794 (1/32)	4.762 (3/16)	3.175 (1/8)	6.350 (1/4)	1.588 (1/16)	19.050 (3/4)	17.4	12,000	20,300
7.938 (5/16)	0.794 (1/32)	4.762 (3/16)	3.175 (1/8)	6.350 (1/4)	1.588 (1/16)	21.828 (55/64)	27.7	22,000	29,000
7.938 (5/16)	0.794 (1/32)	4.762 (3/16)	3.175 (1/8)	6.350 (1/4)	1.588 (1/16)	21.828 (55/64)	27.7	22,000	29,000
9.525 (3/8)	0.794 (1/32)	4.762 (3/16)	3.969 (5/32)	7.938 (5/16)	1.588 (1/16)	26.196 (1 1/64)	55.7	26,400	36,900
9.525 (3/8)	0.794 (1/32)	4.762 (3/16)	3.969 (5/32)	7.938 (5/16)	1.588 (1/16)	26.196 (1 1/64)	55.7	26,400	36,900
11.112 (7/16)	0.794 (1/32)	4.762 (3/16)	3.969 (5/32)	7.938 (5/16)	1.588 (1/16)	32.543 (1 3/32)	100	32,200	49,500
11.112 (7/16)	0.794 (1/32)	4.762 (3/16)	3.969 (5/32)	7.938 (5/16)	1.588 (1/16)	32.543 (1 3/32)	100	32,200	49,500
12.700 (1/2)	0.794 (1/32)	4.762 (3/16)	4.762 (3/16)	11.112 (7/16)	1.588 (1/16)	37.306 (1 15/32)	162	42,600	73,700
12.700 (1/2)	0.794 (1/32)	4.762 (3/16)	4.762 (3/16)	11.112 (7/16)	1.588 (1/16)	37.306 (1 15/32)	162	42,600	73,700

I
CF
CFKR
CFS
NUCF
CR

CAM FOLLOWERS

Inch Series Cam Followers Full Complement Type/With Screwdriver Slot



CR...VR

Stud dia. 4.826 – 31.750mm

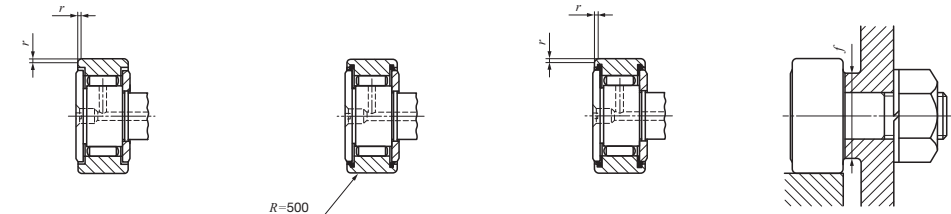
Stud dia. mm (inch)	Identification number				Mass (Ref.) g ⁽²⁾	D	C	d ₁	G UNF	G ₁
	Shield type		Sealed type							
	With crowned outer ring	With cylindrical outer ring	With crowned outer ring	With cylindrical outer ring						
4.826	CR 8 VR	CR 8 V	CR 8 VUUR	CR 8 VUU	9	12.700 (1/2)	8.731 (11/32)	4.826	No.10-32	6.350 (1/4)
	CR 8-1 VR	CR 8-1 V	CR 8-1 VUUR	CR 8-1 VUU	10	12.700 (1/2)	9.525 (3/8)	4.826	No.10-32	6.350 (1/4)
6.350 (1/4)	CR 10 VR	CR 10 V	CR 10 VUUR	CR 10 VUU	19	15.875 (5/8)	10.319 (13/32)	6.350 (1/4)	1/4-28	7.938 (5/16)
	CR 10-1 VR	CR 10-1 V	CR 10-1 VUUR	CR 10-1 VUU	21	15.875 (5/8)	11.112 (7/16)	6.350 (1/4)	1/4-28	7.938 (5/16)
9.525 (3/8)	CR 12 VR	CR 12 V	CR 12 VUUR	CR 12 VUU	36	19.050 (3/4)	12.700 (1/2)	9.525 (3/8)	3/8-24	9.525 (3/8)
	CR 14 VR	CR 14 V	CR 14 VUUR	CR 14 VUU	47	22.225 (7/8)	12.700 (1/2)	9.525 (3/8)	3/8-24	9.525 (3/8)
11.112 (7/16)	CR 16 VR	CR 16 V	CR 16 VUUR	CR 16 VUU	74	25.400 (1)	15.875 (5/8)	11.112 (7/16)	7/16-20	12.700 (1/2)
	CR 18 VR	CR 18 V	CR 18 VUUR	CR 18 VUU	101	28.575 (1 1/8)	15.875 (5/8)	11.112 (7/16)	7/16-20	12.700 (1/2)
12.700 (1/2)	CR 20 VR	CR 20 V	CR 20 VUUR	CR 20 VUU	137	31.750 (1 1/4)	19.050 (3/4)	12.700 (1/2)	1/2-20	15.875 (5/8)
	CR 22 VR	CR 22 V	CR 22 VUUR	CR 22 VUU	160	34.925 (1 3/8)	19.050 (3/4)	12.700 (1/2)	1/2-20	15.875 (5/8)
15.875 (5/8)	CR 24 VR	CR 24 V	CR 24 VUUR	CR 24 VUU	230	38.100 (1 1/2)	22.225 (7/8)	15.875 (5/8)	5/8-18	19.050 (3/4)
	CR 26 VR	CR 26 V	CR 26 VUUR	CR 26 VUU	265	41.275 (1 5/8)	22.225 (7/8)	15.875 (5/8)	5/8-18	19.050 (3/4)
19.050 (3/4)	CR 28 VR	CR 28 V	CR 28 VUUR	CR 28 VUU	372	44.450 (1 3/4)	25.400 (1)	19.050 (3/4)	3/4-16	22.225 (7/8)
	CR 30 VR	CR 30 V	CR 30 VUUR	CR 30 VUU	418	47.625 (1 7/8)	25.400 (1)	19.050 (3/4)	3/4-16	22.225 (7/8)
22.225 (7/8)	CR 32 VR	CR 32 V	CR 32 VUUR	CR 32 VUU	627	50.800 (2)	31.750 (1 1/4)	22.225 (7/8)	7/8-14	25.400 (1)
	CR 36 VR	CR 36 V	CR 36 VUUR	CR 36 VUU	759	57.150 (2 1/4)	31.750 (1 1/4)	22.225 (7/8)	7/8-14	25.400 (1)
31.750 (1 1/4)	—	—	—	CR 48 VUU	1960	76.200 (3)	44.450 (1 3/4)	31.750 (1 1/4)	1 1/4-12	31.750 (1 1/4)

Note⁽¹⁾ For dimensions other than the chamfer dimension (r) and the shape of the outside surface of the outer ring outside surface, refer to the CR...VR drawing.

⁽²⁾ This is the value for the product body only. The values for the accessories shown in Table 13 on page I14 are not included.

Remarks1. Models with a stud diameter d₁ of 6.35 mm or less (marked *) are provided with an oil hole on the stud head only. Other models are provided with one oil hole each on the head, outside surface and end surface of the stud.

- 2. Provided with prepacked grease.
- 3. For the maximum allowable static load, please contact IKO.



CR...V(1)

CR...VUUR(1)

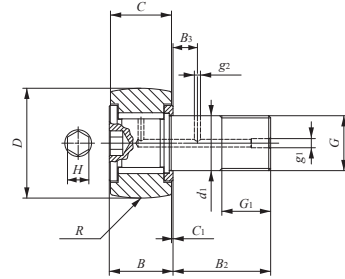
CR...VUU(1)

Boundary dimensions mm(inch)							Mounting dimension f Min. mm(inch)	Maximum tightening torque N-m	Basic dynamic load rating C N	Basic static load rating C ₀ N
B max	B ₂	B ₃	C ₁	g ₁	g ₂	r				
10.2 (0.40)	12.700 (1/2)	— (—)	0.794 (1/32)	*3.175 (1/8)	— (—)	0.397 (1/64)	8.334 (21/64)	1.4	4 260	4 750
10.9 (0.43)	15.875 (5/8)	— (—)	0.794 (1/32)	*3.175 (1/8)	— (—)	0.397 (1/64)	8.334 (21/64)	1.4	4 710	5 410
11.8 (0.46)	15.875 (5/8)	— (—)	0.794 (1/32)	*3.175 (1/8)	— (—)	0.397 (1/64)	11.509 (29/64)	3.4	5 830	7 660
12.5 (0.49)	19.050 (3/4)	— (—)	0.794 (1/32)	*3.175 (1/8)	— (—)	0.397 (1/64)	11.509 (29/64)	3.4	6 340	8 530
14.2 (0.56)	22.225 (7/8)	6.350 (1/4)	0.794 (1/32)	4.762 (3/16)	2.381 (3/32)	0.794 (1/32)	13.494 (17/32)	10.8	8 710	12 300
14.2 (0.56)	22.225 (7/8)	6.350 (1/4)	0.794 (1/32)	4.762 (3/16)	2.381 (3/32)	0.794 (1/32)	15.081 (19/32)	10.8	8 710	12 300
17.3 (0.68)	25.400 (1)	6.350 (1/4)	0.794 (1/32)	4.762 (3/16)	3.175 (1/8)	1.191 (3/64)	17.859 (45/64)	17.4	13 100	22 700
17.3 (0.68)	25.400 (1)	6.350 (1/4)	0.794 (1/32)	4.762 (3/16)	3.175 (1/8)	1.588 (1/16)	19.050 (3/4)	17.4	13 100	22 700
20.4 (0.80)	31.750 (1 1/4)	7.938 (5/16)	0.794 (1/32)	4.762 (3/16)	3.175 (1/8)	1.588 (1/16)	21.828 (55/64)	27.7	23 600	31 700
20.4 (0.80)	31.750 (1 1/4)	7.938 (5/16)	0.794 (1/32)	4.762 (3/16)	3.175 (1/8)	1.588 (1/16)	21.828 (55/64)	27.7	23 600	31 700
23.6 (0.93)	38.100 (1 1/2)	9.525 (3/8)	0.794 (1/32)	4.762 (3/16)	3.969 (5/32)	1.588 (1/16)	26.196 (1 3/64)	55.7	28 200	40 100
23.6 (0.93)	38.100 (1 1/2)	9.525 (3/8)	0.794 (1/32)	4.762 (3/16)	3.969 (5/32)	1.588 (1/16)	26.196 (1 3/64)	55.7	28 200	40 100
26.8 (1.06)	44.450 (1 3/4)	11.112 (7/16)	0.794 (1/32)	4.762 (3/16)	3.969 (5/32)	1.588 (1/16)	32.543 (1 9/32)	100	35 300	55 600
26.8 (1.06)	44.450 (1 3/4)	11.112 (7/16)	0.794 (1/32)	4.762 (3/16)	3.969 (5/32)	1.588 (1/16)	32.543 (1 9/32)	100	35 300	55 600
33.5 (1.32)	50.800 (2)	12.700 (1/2)	0.794 (1/32)	4.762 (3/16)	4.762 (3/16)	1.588 (1/16)	37.306 (1 15/32)	162	45 700	80 600
33.5 (1.32)	50.800 (2)	12.700 (1/2)	0.794 (1/32)	4.762 (3/16)	4.762 (3/16)	1.588 (1/16)	37.306 (1 15/32)	162	45 700	80 600
46.4 (1.83)	63.500 (2 1/2)	15.875 (5/8)	1.588 (1/16)	6.350 (1/4)	4.762 (3/16)	2.381 (3/32)	51.991 (2 3/64)	500	77 600	172 000

I
CF
CFKR
CFS
NUCF
CR

CAM FOLLOWERS

Inch Series Heavy Duty Cam Followers Full Complement Type/Stud Head Hex Hole



CRH...VBR

Stud dia. 6.350 – 50.800mm

Stud dia. mm (inch)	Identification number		Mass (Ref.) g ⁽²⁾	Boundary dimensions mm(inch)					
	Shield type With crowned outer ring	Sealed type With crowned outer ring		D	C	d ₁	G UNF	G ₁	B max
6.350 (1/4)	CRH 8-1 VBR	CRH 8-1 VBUUR	12	12.700 (1/2)	9.525 (3/8)	6.350 (1/4)	1/4 - 28	6.350 (1/4)	11.1 (0.44)
	CRH 9 VBR	CRH 9 VBUUR	15	14.288 (9/16)	9.525 (3/8)	6.350 (1/4)	1/4 - 28	6.350 (1/4)	11.1 (0.44)
7.938 (5/16)	CRH 10-1 VBR	CRH 10-1 VBUUR	23	15.875 (5/8)	11.112 (7/16)	7.938 (5/16)	5/16 - 24	7.938 (5/16)	12.8 (0.50)
	CRH 11 VBR	CRH 11 VBUUR	27	17.462 (11/16)	11.112 (7/16)	7.938 (5/16)	5/16 - 24	7.938 (5/16)	12.8 (0.50)
11.112 (7/16)	CRH 12 VBR	CRH 12 VBUUR	39	19.050 (3/4)	12.700 (1/2)	11.112 (7/16)	7/16 - 20	9.525 (3/8)	14.6 (0.57)
	CRH 14 VBR	CRH 14 VBUUR	49	22.225 (7/8)	12.700 (1/2)	11.112 (7/16)	7/16 - 20	9.525 (3/8)	14.6 (0.57)
15.875 (5/8)	CRH 16 VBR	CRH 16 VBUUR	93	25.400 (1)	15.875 (5/8)	15.875 (5/8)	5/8 - 18	12.700 (1/2)	17.9 (0.70)
	CRH 18 VBR	CRH 18 VBUUR	109	28.575 (1 1/8)	15.875 (5/8)	15.875 (5/8)	5/8 - 18	12.700 (1/2)	17.9 (0.70)
19.050 (3/4)	CRH 20 VBR	CRH 20 VBUUR	176	31.750 (1 1/4)	19.050 (3/4)	19.050 (3/4)	3/4 - 16	15.875 (5/8)	21.0 (0.83)
	CRH 22 VBR	CRH 22 VBUUR	200	34.925 (1 3/8)	19.050 (3/4)	19.050 (3/4)	3/4 - 16	15.875 (5/8)	21.0 (0.83)
22.225 (7/8)	CRH 24 VBR	CRH 24 VBUUR	296	38.100 (1 1/2)	22.225 (7/8)	22.225 (7/8)	7/8 - 14	19.050 (3/4)	24.3 (0.96)
	CRH 26 VBR	CRH 26 VBUUR	329	41.275 (1 5/8)	22.225 (7/8)	22.225 (7/8)	7/8 - 14	19.050 (3/4)	24.3 (0.96)
25.400 (1)	CRH 28 VBR	CRH 28 VBUUR	463	44.450 (1 3/4)	25.400 (1)	25.400 (1)	1-14 UNS	22.225 (7/8)	27.4 (1.08)
	CRH 30 VBR	CRH 30 VBUUR	508	47.625 (1 7/8)	25.400 (1)	25.400 (1)	1-14 UNS	22.225 (7/8)	27.4 (1.08)
28.575 (1 1/8)	CRH 32 VBR	CRH 32 VBUUR	722	50.800 (2)	31.750 (1 1/4)	28.575 (1 1/8)	1 1/8 - 12	25.400 (1)	34.2 (1.35)
	CRH 36 VBR	CRH 36 VBUUR	858	57.150 (2 1/4)	31.750 (1 1/4)	28.575 (1 1/8)	1 1/8 - 12	25.400 (1)	34.2 (1.35)
31.750 (1 1/4)	CRH 40 VBR	CRH 40 VBUUR	1 260	63.500 (2 1/2)	38.100 (1 1/2)	31.750 (1 1/4)	1 1/4 - 12	28.575 (1 1/8)	40.0 (1.57)
	CRH 44 VBR	CRH 44 VBUUR	1 460	69.850 (2 3/4)	38.100 (1 1/2)	31.750 (1 1/4)	1 1/4 - 12	28.575 (1 1/8)	40.0 (1.57)
38.100 (1 1/2)	CRH 48 VBR	CRH 48 VBUUR	2 100	76.200 (3)	44.450 (1 3/4)	38.100 (1 1/2)	1 1/2 - 12	31.750 (1 1/4)	46.4 (1.83)
	CRH 52 VBR	CRH 52 VBUUR	2 380	82.550 (3 1/4)	44.450 (1 3/4)	38.100 (1 1/2)	1 1/2 - 12	31.750 (1 1/4)	46.4 (1.83)
44.450 (1 3/4)	CRH 56 VBR	CRH 56 VBUUR	3 240	88.900 (3 1/2)	50.800 (2)	44.450 (1 3/4)	1 3/4 - 12UN	34.925 (1 3/8)	52.8 (2.08)
50.800 (2)	CRH 64 VBR	CRH 64 VBUUR	4 960	101.600 (4)	57.150 (2 1/4)	50.800 (2)	2-12 UN	38.100 (1 1/2)	59.4 (2.34)



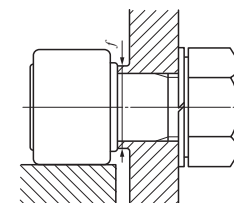
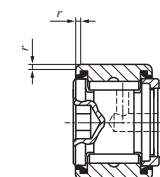
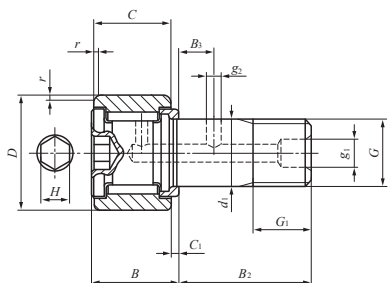
CRH...VBUUR⁽¹⁾

Boundary dimensions mm(inch)	Mounting dimension f Min. mm(inch)	Maximum tightening torque N-m	Basic dynamic load rating C N	Basic static load rating C ₀ N		
					B ₂	B ₃
15.875 (5/8)	8.334 (21/64)	3.4	4 710	5 410		
15.875 (5/8)	8.334 (21/64)	3.4	4 710	5 410		
19.050 (3/4)	11.112 (7/16)	6.8	6 340	8 530		
19.050 (3/4)	11.112 (7/16)	6.8	6 340	8 530		
22.225 (7/8)	13.494 (17/32)	17.6	8 710	12 300		
22.225 (7/8)	13.494 (17/32)	17.6	8 710	12 300		
25.400 (1)	18.256 (23/32)	57.8	13 100	22 700		
25.400 (1)	18.256 (23/32)	57.8	13 100	22 700		
31.750 (1 1/4)	24.209 (61/64)	103	23 600	31 700		
31.750 (1 1/4)	24.209 (61/64)	103	23 600	31 700		
38.100 (1 1/2)	26.988 (1 1/16)	162	28 200	40 100		
38.100 (1 1/2)	26.988 (1 1/16)	162	28 200	40 100		
44.450 (1 3/4)	32.941 (1 19/64)	258	35 300	55 600		
44.450 (1 3/4)	32.941 (1 19/64)	258	35 300	55 600		
50.800 (2)	37.306 (1 15/32)	356	45 700	80 600		
50.800 (2)	37.306 (1 15/32)	356	45 700	80 600		
57.150 (2 1/4)	40.878 (1 39/64)	500	61 400	116 000		
57.150 (2 1/4)	40.878 (1 39/64)	500	61 400	116 000		
63.500 (2 1/2)	51.991 (2 3/64)	892	77 600	172 000		
63.500 (2 1/2)	51.991 (2 3/64)	892	77 600	172 000		
69.850 (2 3/4)	59.928 (2 23/64)	1450	111 000	239 000		
88.900 (3 1/2)	64.691 (2 35/64)	2190	142 000	317 000		

Note⁽¹⁾ For dimensions other than the chamfer dimension (r) and the shape of the outside surface of the outer ring outside surface, refer to the CRH...VBR drawing.
 (2) This is the value for the product body only. The values for the accessories shown in Table 13 on page I14 are not included.
 Remarks 1. Models with a stud diameter d₁ of 7.938 mm or less have no oil hole. Other models are provided with one oil hole each on the outside surface and end surface of the stud.
 2. Provided with prepacked grease.
 3. For the maximum allowable static load, please contact IKO.

CAM FOLLOWERS

Inch Series Heavy Duty Cam Followers Full Complement Type/Stud Head Hex Hole



Stud dia. 6.350 – 50.800mm

CRH...VB

Stud dia. mm (inch)	Identification number		Mass (Ref.) g ⁽²⁾	Boundary dimensions mm (inch)					
	Shield type With cylindrical outer ring	Sealed type With cylindrical outer ring		D	C	d ₁	G UNF	G ₁	B max
6.350 (1/4)	CRH 8-1 VB	CRH 8-1 VBUU	12	12.700 (1/2)	9.525 (3/8)	6.350 (1/4)	1/4 - 28	6.350 (1/4)	11.1 (0.44)
	CRH 9 VB	CRH 9 VBUU	15	14.288 (9/16)	9.525 (3/8)	6.350 (1/4)	1/4 - 28	6.350 (1/4)	11.1 (0.44)
7.938 (5/16)	CRH 10-1 VB	CRH 10-1 VBUU	23	15.875 (5/8)	11.112 (7/16)	7.938 (5/16)	5/16 - 24	7.938 (5/16)	12.8 (0.50)
	CRH 11 VB	CRH 11 VBUU	27	17.462 (11/16)	11.112 (7/16)	7.938 (5/16)	5/16 - 24	7.938 (5/16)	12.8 (0.50)
11.112 (7/16)	CRH 12 VB	CRH 12 VBUU	39	19.050 (3/4)	12.700 (1/2)	11.112 (7/16)	7/16 - 20	9.525 (3/8)	14.6 (0.57)
	CRH 14 VB	CRH 14 VBUU	49	22.225 (7/8)	12.700 (1/2)	11.112 (7/16)	7/16 - 20	9.525 (3/8)	14.6 (0.57)
15.875 (5/8)	CRH 16 VB	CRH 16 VBUU	93	25.400 (1)	15.875 (5/8)	15.875 (5/8)	5/8 - 18	12.700 (1/2)	17.9 (0.70)
	CRH 18 VB	CRH 18 VBUU	109	28.575 (1 1/8)	15.875 (5/8)	15.875 (5/8)	5/8 - 18	12.700 (1/2)	17.9 (0.70)
19.050 (3/4)	CRH 20 VB	CRH 20 VBUU	176	31.750 (1 1/4)	19.050 (3/4)	19.050 (3/4)	3/4 - 16	15.875 (5/8)	21.0 (0.83)
	CRH 22 VB	CRH 22 VBUU	200	34.925 (1 3/8)	19.050 (3/4)	19.050 (3/4)	3/4 - 16	15.875 (5/8)	21.0 (0.83)
22.225 (7/8)	CRH 24 VB	CRH 24 VBUU	296	38.100 (1 1/2)	22.225 (7/8)	22.225 (7/8)	7/8 - 14	19.050 (3/4)	24.3 (0.96)
	CRH 26 VB	CRH 26 VBUU	329	41.275 (1 5/8)	22.225 (7/8)	22.225 (7/8)	7/8 - 14	19.050 (3/4)	24.3 (0.96)
25.400 (1)	CRH 28 VB	CRH 28 VBUU	463	44.450 (1 3/4)	25.400 (1)	25.400 (1)	1 - 14 UNS	22.225 (7/8)	27.4 (1.08)
	CRH 30 VB	CRH 30 VBUU	508	47.625 (1 7/8)	25.400 (1)	25.400 (1)	1 - 14 UNS	22.225 (7/8)	27.4 (1.08)
28.575 (1 1/8)	CRH 32 VB	CRH 32 VBUU	722	50.800 (2)	31.750 (1 1/4)	28.575 (1 1/8)	1 1/8 - 12	25.400 (1)	34.2 (1.35)
	CRH 36 VB	CRH 36 VBUU	858	57.150 (2 1/4)	31.750 (1 1/4)	28.575 (1 1/8)	1 1/8 - 12	25.400 (1)	34.2 (1.35)
31.750 (1 1/4)	CRH 40 VB	CRH 40 VBUU	1 260	63.500 (2 1/2)	38.100 (1 1/2)	31.750 (1 1/4)	1 1/4 - 12	28.575 (1 1/8)	40.0 (1.57)
	CRH 44 VB	CRH 44 VBUU	1 460	69.850 (2 3/4)	38.100 (1 1/2)	31.750 (1 1/4)	1 1/4 - 12	28.575 (1 1/8)	40.0 (1.57)
38.100 (1 1/2)	CRH 48 VB	CRH 48 VBUU	2 100	76.200 (3)	44.450 (1 3/4)	38.100 (1 1/2)	1 1/2 - 12	31.750 (1 1/4)	46.4 (1.83)
	CRH 52 VB	CRH 52 VBUU	2 380	82.550 (3 1/4)	44.450 (1 3/4)	38.100 (1 1/2)	1 1/2 - 12	31.750 (1 1/4)	46.4 (1.83)
44.450 (1 3/4)	CRH 56 VB	CRH 56 VBUU	3 240	88.900 (3 1/2)	50.800 (2)	44.450 (1 3/4)	1 3/4 - 12UN	34.925 (1 3/8)	52.8 (2.08)
50.800 (2)	CRH 64 VB	CRH 64 VBUU	4 960	101.600 (4)	57.150 (2 1/4)	50.800 (2)	2 - 12 UN	38.100 (1 1/2)	59.4 (2.34)

Note⁽¹⁾ For dimensions other than the chamfer dimension (r) and the shape of the outside surface of the outer ring outside surface, refer to the CRH...VB drawing.

⁽²⁾ This is the value for the product body only. The values for the accessories shown in Table 13 on page I14 are not included.

Remarks 1. Models with a stud diameter d₁ of 7.938 mm or less have no oil hole. Other models are provided with one oil hole each on the outside surface and end surface of the stud.

- 2. Provided with prepacked grease.
- 3. For the maximum allowable static load, please contact IKO.

CRH...VBUU⁽¹⁾

Boundary dimensions mm (inch)							Mounting dimension f Min. mm (inch)	Maximum tightening torque N-m	Basic dynamic load rating C N	Basic static load rating C ₀ N
B ₂	B ₃	C ₁	g ₁	g ₂	H	r				
15.875 (5/8)	— (—)	0.794 (1/32)	— (—)	— (—)	3.175 (1/8)	0.397 (1/64)	8.334 (21/64)	3.4	4 710	5 410
15.875 (5/8)	— (—)	0.794 (1/32)	— (—)	— (—)	3.175 (1/8)	0.397 (1/64)	8.334 (21/64)	3.4	4 710	5 410
19.050 (3/4)	— (—)	0.794 (1/32)	— (—)	— (—)	3.175 (1/8)	0.397 (1/64)	11.112 (7/16)	6.8	6 340	8 530
19.050 (3/4)	— (—)	0.794 (1/32)	— (—)	— (—)	3.175 (1/8)	0.397 (1/64)	11.112 (7/16)	6.8	6 340	8 530
22.225 (7/8)	6.350 (1/4)	0.794 (1/32)	4.762 (3/16)	2.381 (3/32)	4.762 (3/16)	0.794 (1/32)	13.494 (17/32)	17.6	8 710	12 300
22.225 (7/8)	6.350 (1/4)	0.794 (1/32)	4.762 (3/16)	2.381 (3/32)	4.762 (3/16)	0.794 (1/32)	13.494 (17/32)	17.6	8 710	12 300
25.400 (1)	6.350 (1/4)	1.588 (1/16)	4.762 (3/16)	2.381 (3/32)	6.350 (1/4)	1.191 (3/64)	18.256 (23/32)	57.8	13 100	22 700
25.400 (1)	6.350 (1/4)	1.588 (1/16)	4.762 (3/16)	2.381 (3/32)	6.350 (1/4)	1.588 (1/16)	18.256 (23/32)	57.8	13 100	22 700
31.750 (1 1/4)	7.938 (5/16)	1.588 (1/16)	4.762 (3/16)	2.381 (3/32)	6.350 (1/4)	1.588 (1/16)	24.209 (61/64)	103	23 600	31 700
31.750 (1 1/4)	7.938 (5/16)	1.588 (1/16)	4.762 (3/16)	2.381 (3/32)	6.350 (1/4)	1.588 (1/16)	24.209 (61/64)	103	23 600	31 700
38.100 (1 1/2)	9.525 (3/8)	1.588 (1/16)	4.762 (3/16)	2.381 (3/32)	7.938 (5/16)	1.588 (1/16)	26.988 (1 1/16)	162	28 200	40 100
38.100 (1 1/2)	9.525 (3/8)	1.588 (1/16)	4.762 (3/16)	2.381 (3/32)	7.938 (5/16)	1.588 (1/16)	26.988 (1 1/16)	162	28 200	40 100
44.450 (1 3/4)	11.112 (7/16)	1.588 (1/16)	4.762 (3/16)	2.381 (3/32)	7.938 (5/16)	1.588 (1/16)	32.941 (1 19/64)	258	35 300	55 600
44.450 (1 3/4)	11.112 (7/16)	1.588 (1/16)	4.762 (3/16)	2.381 (3/32)	7.938 (5/16)	1.588 (1/16)	32.941 (1 19/64)	258	35 300	55 600
50.800 (2)	12.700 (1/2)	1.588 (1/16)	4.762 (3/16)	3.175 (1/8)	11.112 (7/16)	1.588 (1/16)	37.306 (1 15/32)	356	45 700	80 600
50.800 (2)	12.700 (1/2)	1.588 (1/16)	4.762 (3/16)	3.175 (1/8)	11.112 (7/16)	1.588 (1/16)	37.306 (1 15/32)	356	45 700	80 600
57.150 (2 1/4)	14.288 (9/16)	1.588 (1/16)	4.762 (3/16)	3.175 (1/8)	12.700 (1/2)	2.381 (3/32)	40.878 (1 39/64)	500	61 400	116 000
57.150 (2 1/4)	14.288 (9/16)	1.588 (1/16)	4.762 (3/16)	3.175 (1/8)	12.700 (1/2)	2.381 (3/32)	40.878 (1 39/64)	500	61 400	116 000
63.500 (2 1/2)	15.875 (5/8)	1.588 (1/16)	6.350 (1/4)	3.175 (1/8)	19.050 (3/4)	2.381 (3/32)	51.991 (2 3/64)	892	77 600	172 000
63.500 (2 1/2)	15.875 (5/8)	1.588 (1/16)	6.350 (1/4)	3.175 (1/8)	19.050 (3/4)	2.381 (3/32)	51.991 (2 3/64)	892	77 600	172 000
69.850 (2 3/4)	17.462 (11/16)	1.588 (1/16)	6.350 (1/4)	3.175 (1/8)	19.050 (3/4)	2.381 (3/32)	59.928 (2 23/64)	1 450	111 000	239 000
88.900 (3 1/2)	19.050 (3/4)	1.588 (1/16)	6.350 (1/4)	3.175 (1/8)	19.050 (3/4)	2.381 (3/32)	64.691 (2 35/64)	2 190	142 000	317 000

I
CF
CFKR
CFS
NUCF
CR

ROLLER FOLLOWERS

- Separable Roller Followers
- Non-separable Roller Followers
- C-Lube Roller Followers
- Cylindrical Roller Followers

High carbon steel made
Stainless steel made



Structure and Features

IKO Roller Followers are bearings designed for outer ring rotation, in which needle rollers are incorporated in a thick walled outer ring. Both crowned and cylindrical outer rings are available. The outer rings run directly on mating cam guide surfaces, and the crowned outer ring is effective in relieving the edge load caused by mounting errors. The cylindrical outer ring, on the other hand, has a large contact area with the mating cam guide surface and is suitable for applications involving large loads or low cam guide surface hardness.

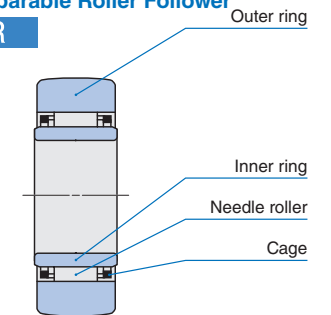
In Roller Followers, there are two types of bearings available, the caged type and the full complement type. The caged type is useful for applications at high-speed rotation. The full complement type, on the other hand, is suitable for heavy-load applications at low-speed rotation or oscillating motions.

Roller Followers include separable and non-separable types. Also, in addition to the open type, shield type and sealed type are available. The clearances between the side plates and outer ring of the shield type are narrow, and form labyrinths. In the sealed type, special synthetic rubber seals are assembled in these clearances, and they are effective in preventing penetration of dust and dirt.

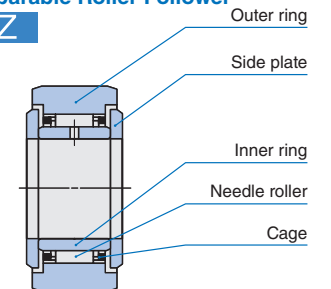
These bearings are available in a variety of types to suit almost any kind of application. They are widely used for cam mechanisms and for linear motions of conveying equipment.

Structures of Roller Followers

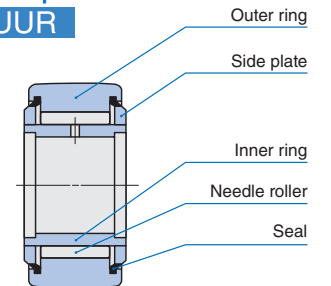
Structure of Separable Roller Follower NAST...R



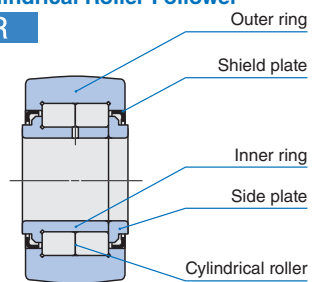
Structure of Separable Roller Follower NAST...ZZ



Structure of Non-separable Roller Follower NART...VUUR



Structure of Cylindrical Roller Follower NURT...R



I
NAST
NART
NURT
CRY

Types

In Roller Followers, types shown in Table 1 are available.

Table 1 Type of Roller Followers

Type			With cage		Full complement type		
			Crowned outer ring	Cylindrical outer ring	Crowned outer ring	Cylindrical outer ring	
Metric series	Separable Roller Followers RNAS ^t , NAST	Without inner ring	Open type	RNAS ^t ... R	RNAS ^t	—	—
		With inner ring	Open type	NAS ^t ... R	NAS ^t	—	—
			Shield type	NAS ^t ... ZZ R	NAS ^t ... ZZ	—	—
			Sealed type	NAS ^t ... ZZUUR	NAS ^t ... ZZUU	—	—
	Non-separable Roller Followers NART	High carbon steel made	Shield type	NART ... R	—	NART ... V R	—
			Sealed type	NART ... UU R	—	NART ... VUUR	—
		Stainless steel made	Shield type	NART ... F R	—	—	—
			Sealed type	NART ... FUU R	—	—	—
	C-Lube Roller Followers NART ... /SG		Sealed type	NART ... UUR/SG	—	—	—
	Cylindrical Roller Followers NURT		Shield type	—	—	NURT ... R	NURT
Inch series	Non-separable Roller Followers CRY		Shield type	—	—	CRY ... V R	CRY ... V
			Sealed type	—	—	CRY ... VUUR	CRY ... VUU

Separable Roller Followers

These bearings are assembled by combining an outer ring, inner ring and Needle Roller Cage, which can be separated from one another. Thus, handling is easy. Oil lubrication is also easy, making them suitable for high-speed rotations.

There are two types: type without inner ring RNAS^t and type with inner ring NAS^t. The type with inner ring includes open type, shield type, and sealed type.

Non-separable Roller Followers

These non-separable type bearings have side plates fixed on both sides of the inner ring, and include the caged type and the full complement type. Both shield type and sealed type are available. As well, these bearings also offer a highly corrosion-resistant stainless steel specification, of which the products are suitable for applications where rust prevention oil is not preferred, such as in cleanroom environments.

Inch series Non-separable Roller Followers are full complement type bearings with black oxide surface treatment.

C-Lube Roller Followers

These Roller Followers are lubricated with C-Lube, an IKO original thermosetting solid-type lubricant which fills the inner space of the bearing. C-Lube is lubricant made of a lot of lubricant and fine particles of super-high molecular polyolefin that are solidified by heat treatment. As the bearing rotates, the lubricant oozes out onto the raceway in proper quantities, maintaining the lubrication performance for a long period of time.

Cylindrical Roller Followers

These bearings are full complement type bearings incorporating double rows of full complement cylindrical rollers in the outer ring, and can withstand large radial loads.

Additionally, the outer ring is guided by the outer ring shoulder and the end face of cylindrical rollers to the axial direction.

Identification Number

Some examples of the identification number of Roller Followers are shown below.

Examples of identification number

Example 1 → NAST 10 ZZUU R

Example 2 → NART 10 V UU R

Example 3 → NART 15 UU R /SG

Example 4 → NART 12 F UU R

Model code		
Metric series	RNAS ^t	Separable Roller Follower Without inner ring
	NAST	Separable Roller Follower With inner ring
	NART	Non-separable Roller Follower
	NART ... /SG	C-Lube Roller Follower
Inch series	NURT	Cylindrical Roller Follower
	CRY	Non-separable Roller Follower

Size	
The size indicates the bore diameter of the inner ring. (unit: mm)	
In the inch series, the outer diameter of the outer ring is indicated in units of 1/16 inch.	

Type of material	
No symbol	High carbon steel made
F(1)	Stainless steel made

Roller guide method	
No symbol	With cage
V	Full complement type

Seal structure (Separable Roller Follower)	
No symbol	Open type
ZZ	Shield type
ZZUU	Sealed type

Seal structure (Other Roller Follower)	
No symbol	Shield type
UU	Sealed type

Shape of outer ring outside surface	
R	With crowned outer ring
No symbol	With cylindrical outer ring

Note(1) Applicable to Non-separable Roller Followers only

I
NAST
NURT
CRY

Accuracy

Dimensional accuracy and rotational accuracy of Roller Followers are based on Tables 2, 3 and 4. Tolerances for the smallest single roller set bore diameter of Separable Roller Followers are shown in Table 5. Roller Followers with special accuracy can also be manufactured. Please contact IKO.

Table 2 Tolerances

unit: μm

Dimensions and symbols	Series	Metric series		Inch series	
		Crowned outer ring	Cylindrical outer ring	Crowned outer ring	Cylindrical outer ring
Bore dia. of inner ring d	$d \leq 19.05$	See Table 3.		+ 5 - 10	+ 5
	$19.05 < d$			+ 2 - 12	- 10
Outside dia. of outer ring D		0 - 50	See Table 4.	0 - 50	0 - 25
Width of outer ring C		0 - 120		0 - 130	
Width of inner ring B	Separable Roller Follower	0 - 120		-	
Width of bearing B	Non-separable Roller Follower	h12	-	+ 130	
	Cylindrical Roller Follower		h12	- 250	
Roller set bore dia. F_w	Separable Roller Follower	See Table 5.		-	

Table 3 Tolerances and allowable values of inner rings (Metric series)

unit: μm

d Nominal bore dia. mm		Δ_{dmp} Single plane mean bore dia. deviation		V_{dp} ⁽¹⁾ Bore dia. variation in a single radial plane	V_{dmp} ⁽¹⁾ Mean bore dia. variation	K_{ia} ⁽¹⁾ Radial runout of assembled bearing inner ring	V_{Bs} Width variation
Over	Incl.	High	Low	(Max.)	(Max.)	(Max.)	(Max.)
2.5	10	0	- 8	10	6	10	15
10	18	0	- 8	10	6	10	20
18	30	0	- 10	13	8	13	20
30	50	0	- 12	15	9	15	20

Table 4 Tolerances and allowable values of outer rings (Metric series)

unit: μm

D Nominal outside dia. of outer ring mm		Δ_{Dmp} Single plane mean outside dia. deviation		V_{Dp} ⁽¹⁾ Outside dia. variation in a single radial plane	V_{Dmp} ⁽¹⁾ Mean outside dia. variation	K_{ea} ⁽¹⁾ Radial runout of assembled bearing outer ring	V_{Cs} Width variation
Over	Incl.	High	Low	(Max.)	(Max.)	(Max.)	(Max.)
6	18	0	- 8	10	6	15	Same as the tolerance values of V_{Bs} for d of the inner of the same bearing
18	30	0	- 9	12	7	15	
30	50	0	- 11	14	8	20	
50	80	0	- 13	16	10	25	
80	120	0	- 15	19	11	35	

Note⁽¹⁾ Also applicable to the inch series.

Table 5 Tolerances of smallest single roller set bore diameter $F_{ws\ min}$

unit: μm

F_w Nominal roller set bore diameter mm		$\Delta_{Fws\ min}$ Deviation of smallest single roller set bore diameter	
Over	Incl.	High	Low
6	10	+ 22	+ 13
10	18	+ 27	+ 16
18	30	+ 33	+ 20
30	50	+ 41	+ 25
50	80	+ 49	+ 30

Clearance

Radial internal clearances of Roller Followers are based on Table 6.

Table 6 Radial internal clearance

unit: μm

Identification number ⁽¹⁾				Radial internal clearance	
Metric series			Inch series	Min.	Max.
Separable Roller Followers	Non-separable Roller Followers ⁽²⁾	Cylindrical Roller Followers	Non-separable Roller Followers		
NAST 6R	NART 5R	-	-	5	20
NAST 8R ~ NAST12R	NART 6R ~ NART12R	-	-	5	25
NAST15R ~ NAST25R	NART15R ~ NART20R	-	-	10	30
NAST30R ~ NAST40R	NART25R ~ NART40R	-	-	10	40
NAST45R, NAST50R	NART45R, NART50R	-	-	15	50
-	-	NURT15R ~ NURT30-1R	-	20	45
-	-	NURT35R ~ NURT40-1R	-	25	50
-	-	NURT45R ~ NURT50-1R	-	30	60
-	-	-	CRY12R ~ CRY56R	35	60
-	-	-	CRY64R	45	70

Note⁽¹⁾ Also applicable to the full complement type, cylindrical outer ring type, shield type and sealed type.

⁽²⁾ Also applicable to C-Lube Roller Followers.

Fit

Roller Followers are generally used under the loading conditions in which the load direction is fixed in relation to the inner ring and rotates in relation to the outer ring. The recommended fits for shafts are shown in Table 7. Those for the inch series are shown in the dimension table.

Table 7 Recommended fit (Metric series)

Type	Tolerance class of shaft
Separable Roller Followers	without inner ring: k5, k6 with inner ring: g6, h6
Non-separable Roller Followers ⁽¹⁾	g6, h6
Cylindrical Roller Followers	

Note⁽¹⁾ Also applicable to C-Lube Roller Followers.

Maximum allowable static load

The load that is applicable to Roller Followers is, in some cases, determined by the strength of the outer ring rather than by the load rating of the needle roller bearing. Therefore, the maximum allowable load that is limited by the strength of outer ring is specified.

Track Capacity

Track capacity is defined as the load that can be continuously applied on a Roller Follower placed on a steel cam guide surface without causing deformation and indentation on the cam guide surface when the outer ring of the Roller Follower makes contact with the mating cam guide surface (plane). The track capacities shown in Tables 8.1 and 8.2 are applicable when the hardness of the mating cam guide surface is 40HRC

(Tensile strength 1250N/mm²). When the hardness of the mating cam guide surface differs from 40HRC, the track capacity is obtained by multiplying the value by the track capacity factor shown in Table 9.

If lubrication between the outer ring and the mating cam guide surface is insufficient, seizure and/or wear may occur depending on the application. Therefore, pay attention to lubrication and surface roughness of the mating cam guide especially in the case of high-speed rotation such as for cam mechanisms.

Table 8.1 Track capacity (Metric series)

unit: N

Roller Followers with crowned outer ring				Roller Followers with cylindrical outer ring					
Identification number ⁽¹⁾			Track capacity	Identification number	Track capacity	Identification number ⁽²⁾	Track capacity	Identification number	Track capacity
Separable Roller Followers	Non-separable ⁽³⁾ Roller Followers	Cylindrical Roller Followers							
RNAST 5R	NART 5R	—	1 040	RNAST 5	2 310	—	—	—	—
(R)NAST 6R	NART 6R	—	1 330	(R)NAST 6	3 550	NAST 6ZZ	3 550	—	—
(R)NAST 8R	NART 8R	—	1 850	(R)NAST 8	3 980	NAST 8ZZ	4 490	—	—
(R)NAST10R	NART10R	—	2 470	(R)NAST10	5 610	NAST10ZZ	6 890	—	—
(R)NAST12R	NART12R	—	2 710	(R)NAST12	5 990	NAST12ZZ	7 350	—	—
(R)NAST15R	NART15R	—	3 060	(R)NAST15	6 550	NAST15ZZ	8 030	NURT15	11 500
—	—	NURT15-1R	3 910	—	—	—	—	NURT15-1	13 700
(R)NAST17R	NART17R	—	3 660	(R)NAST17	10 900	NAST17ZZ	11 700	NURT17	13 600
—	—	NURT17-1R	4 530	—	—	—	—	NURT17-1	16 000
(R)NAST20R	NART20R	—	4 530	(R)NAST20	12 800	NAST20ZZ	13 800	NURT20	20 000
—	—	NURT20-1R	5 190	—	—	—	—	NURT20-1	22 100
(R)NAST25R	NART25R	—	5 190	(R)NAST25	14 100	NAST25ZZ	15 300	NURT25	22 100
—	—	NURT25-1R	6 580	—	—	—	—	NURT25-1	26 400
(R)NAST30R	NART30R	—	6 580	(R)NAST30	22 100	NAST30ZZ	22 100	NURT30	31 600
—	—	NURT30-1R	8 020	—	—	—	—	NURT30-1	36 700
(R)NAST35R	NART35R	—	8 020	(R)NAST35	25 700	NAST35ZZ	25 700	NURT35	36 700
—	—	NURT35-1R	9 220	—	—	—	—	NURT35-1	40 800
(R)NAST40R	NART40R	—	9 220	(R)NAST40	26 900	NAST40ZZ	30 300	NURT40	44 200
—	—	NURT40-1R	10 800	—	—	—	—	NURT40-1	49 700
(R)NAST45R	NART45R	—	9 990	(R)NAST45	28 500	NAST45ZZ	32 200	NURT45	47 000
—	—	NURT45-1R	12 400	—	—	—	—	NURT45-1	55 300
(R)NAST50R	NART50R	—	10 800	(R)NAST50	30 200	NAST50ZZ	34 000	NURT50	49 700
—	—	NURT50-1R	14 000	—	—	—	—	NURT50-1	60 800

Notes⁽¹⁾ Also applicable to the full complement type, shield type, and sealed type. ⁽²⁾ Also applicable to C-Lube Roller Followers. ⁽³⁾ Also applicable to the sealed type.

Table 8.2 Track capacity (Inch series)

unit: N

Crowned outer ring		Cylindrical outer ring	
Identification number ⁽¹⁾	Track capacity	Identification number ⁽¹⁾	Track capacity
CRY12R	853	CRY12	4 490
CRY14R	1 050	CRY14	5 240
CRY16R	1 420	CRY16	7 270
CRY18R	1 660	CRY18	7 700
CRY20R	2 160	CRY20	10 700
CRY22R	2 450	CRY22	11 800
CRY24R	3 410	CRY24	15 400
CRY26R	3 820	CRY26	16 700
CRY28R	4 210	CRY28	21 000
CRY30R	4 610	CRY30	22 500
CRY32R	5 690	CRY32	30 800
CRY36R	6 640	CRY36	34 700
CRY40R	8 970	CRY40	44 900
CRY44R	10 200	CRY44	49 400
CRY48R	11 400	CRY48	64 300
CRY52R	12 700	CRY52	69 600
CRY56R	14 100	CRY56	87 000
CRY64R	16 800	CRY64	113 000

Note⁽¹⁾ Also applicable to the sealed type.

Table 9 Track capacity factor

Hardness HRC	Tensile strength N/mm ²	Track capacity factor	
		Crowned outer ring	Cylindrical outer ring
20	760	0.22	0.37
25	840	0.31	0.46
30	950	0.45	0.58
35	1 080	0.65	0.75
38	1 180	0.85	0.89
40	1 250	1.00	1.00
42	1 340	1.23	1.15
44	1 435	1.52	1.32
46	1 530	1.85	1.51
48	1 635	2.27	1.73
50	1 760	2.80	1.99
52	1 880	3.46	2.29
54	2 015	4.21	2.61
56	2 150	5.13	2.97
58	2 290	6.26	3.39

Allowable Rotational Speed

The allowable rotational speed of Roller Followers is affected by mounting and operating conditions. For *dn* values with only pure radial load applied, use the maximum values in Table 10 or less as a guideline. Under actual operating conditions, use the recommended *dn* values in Table 10 as a guideline in consideration of the effect of axial loads. For use with oscillating rotation, use a C-Lube Roller Follower *dn* value of 8,000 or less as a guideline. For use with one-way or continuous rotation, please contact IKO.

Table 10 *dn* values of Roller Followers⁽¹⁾

Type	Grease		Oil	
	Maximum	Recommended	Maximum	Recommended
Caged type	84 000	8 400	140 000	14 000
Full complement type	42 000	4 200	70 000	7 000
Cylindrical Roller Follower	72 000	7 200	120 000	12 000
C-Lube Roller Followers	8 000		8 000	

Note⁽¹⁾ *dn* value = *d* × *n*
where, *d*: Bore diameter of bearing mm
n: Rotational speed min⁻¹

Lubrication

In Sealed Type Roller Followers, Heavy Duty Type Roller Followers and Inch series Roller Followers, ALVANIA GREASE S2 (Shell Lubricants Japan K.K.) is prepacked as the lubricating grease.

For Roller Followers without prepacked grease, grease or oil should be supplied through the oil hole of the inner ring for use. If they are used without lubrication, wear of rolling contact surfaces may take place, leading to a short bearing life.

Oil Hole

Open Type Separable Roller Followers have no oil hole. Inner rings of other types of Metric series Roller Followers have an oil groove and an oil hole.

Mounting

① In case of shield and sealed types, match the side surface correctly to the mating seating surface indicated by the dimension *a* shown in the dimension table, and fix them. (See Fig. 1.)

In addition, the mounting part should make even contact with the entire side plate surface. Uneven contact may cause increased rotational torque and shorten the service life.

② When mounting Roller Followers, pay special attention to avoid locating the oil hole of the inner ring within the loading zone. This may lead to a short bearing life. (See Fig. 2.)

③ When mounting Sealed Type Separable Roller Followers, do not cause the side plates to come off. If they come off, set them again in place taking care to avoid damaging the seal lips.

④ In case of Roller Followers without an inner ring, the shaft requires heat treatment and grinding finish. The recommended surface hardness of the shaft is 58 ~ 64HRC, and the recommended roughness of the shaft is 0.2 μm *R_a* or less.

Also, the outer ring and cage are guided by side surfaces of the mounting parts. Therefore, it is recommended that the side surfaces of the mounting parts be finished by grinding or at least by machining. (See Fig. 3.)

⑤ In Non-separable Roller Followers, the side plates are press-fitted. Therefore, when mounting the Roller Followers, do not push the side plates/outer rings.

Pushing on the side plates or outer rings may cause unsatisfactory product performance.

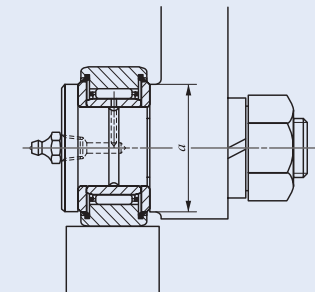


Fig. 1 Mating seating dimension "a"

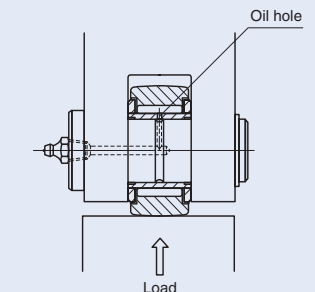


Fig. 2 Position of oil hole and load direction

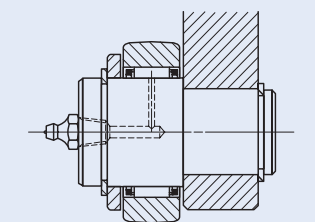
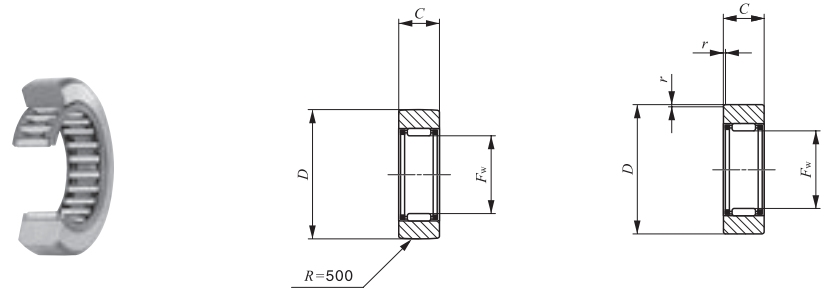


Fig. 3 Mounting example of Roller Follower without inner ring

1N=0.102kgf=0.2248lbs.
1mm=0.03937inch

ROLLER FOLLOWERS

Separable Roller Followers, Open Type **With Cage/Without Inner Ring**



Shaft dia. 7 – 60mm

RNAS...R

RNAST

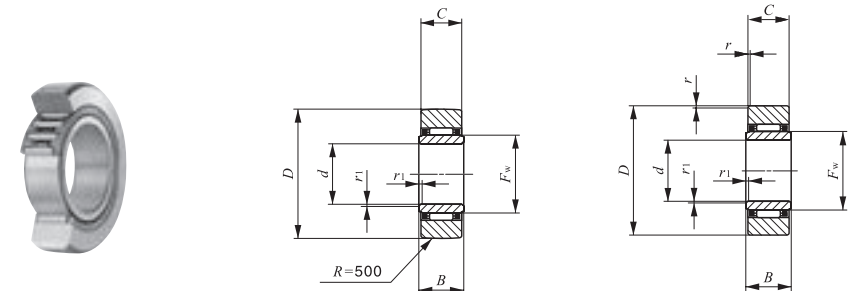
Shaft dia. mm	Identification number		Mass (Ref.) g	Boundary dimensions mm				Basic dynamic load rating C N	Basic static load rating C ₀ N
	Open type			F _w	D	C	r _{s min} ⁽¹⁾		
	Crowned outer ring	Cylindrical outer ring							
7	RNAST 5 R	RNAST 5	8.9	7	16	7.8	0.3	2 710	2 390
10	RNAST 6 R	RNAST 6	13.9	10	19	9.8	0.3	4 160	4 550
12	RNAST 8 R	RNAST 8	23.5	12	24	9.8	0.6	5 650	5 890
14	RNAST 10 R	RNAST 10	42.5	14	30	11.8	1	9 790	9 680
16	RNAST 12 R	RNAST 12	49.5	16	32	11.8	1	10 500	10 900
20	RNAST 15 R	RNAST 15	50	20	35	11.8	1	12 400	14 300
22	RNAST 17 R	RNAST 17	90	22	40	15.8	1	17 600	20 900
25	RNAST 20 R	RNAST 20	135	25	47	15.8	1	19 400	24 500
30	RNAST 25 R	RNAST 25	152	30	52	15.8	1	20 800	28 400
38	RNAST 30 R	RNAST 30	255	38	62	19.8	1	30 500	45 400
42	RNAST 35 R	RNAST 35	375	42	72	19.8	1	32 400	50 600
50	RNAST 40 R	RNAST 40	420	50	80	19.8	1.5	35 900	61 100
55	RNAST 45 R	RNAST 45	460	55	85	19.8	1.5	37 400	66 400
60	RNAST 50 R	RNAST 50	500	60	90	19.8	1.5	38 900	71 700

Note⁽¹⁾ Minimum allowable value of chamfer dimension r

Remarks1. No oil hole is provided.

2. Not provided with prepacked grease. Perform proper lubrication for use.

Separable Roller Followers, Open Type **With Cage/With Inner Ring**



Shaft dia. 6 – 50mm

NAST...R

NAST

Shaft dia. mm	Identification number		Mass (Ref.) g	Boundary dimensions mm						Basic dynamic load rating C N	Basic static load rating C ₀ N	Assembled inner ring	
	Open type			d	D	B	C	r _{s min} ⁽¹⁾	r _{1s min} ⁽¹⁾				F _w
	Crowned outer ring	Cylindrical outer ring											
6	NAST 6 R	NAST 6	17.8	6	19	10	9.8	0.3	0.3	10	4 160	4 550	LRT 61010 S
8	NAST 8 R	NAST 8	28	8	24	10	9.8	0.6	0.3	12	5 650	5 890	LRT 81210 S
10	NAST 10 R	NAST 10	49.5	10	30	12	11.8	1	0.3	14	9 790	9 680	LRT 101412 S
12	NAST 12 R	NAST 12	58	12	32	12	11.8	1	0.3	16	10 500	10 900	LRT 121612 S
15	NAST 15 R	NAST 15	62	15	35	12	11.8	1	0.3	20	12 400	14 300	LRT 152012 S
17	NAST 17 R	NAST 17	109	17	40	16	15.8	1	0.3	22	17 600	20 900	LRT 172216 S
20	NAST 20 R	NAST 20	157	20	47	16	15.8	1	0.3	25	19 400	24 500	LRT 202516 S
25	NAST 25 R	NAST 25	180	25	52	16	15.8	1	0.3	30	20 800	28 400	LRT 253016 S
30	NAST 30 R	NAST 30	320	30	62	20	19.8	1	0.6	38	30 500	45 400	LRT 303820 S
35	NAST 35 R	NAST 35	440	35	72	20	19.8	1	0.6	42	32 400	50 600	LRT 354220 S
40	NAST 40 R	NAST 40	530	40	80	20	19.8	1.5	1	50	35 900	61 100	LRT 405020 S
45	NAST 45 R	NAST 45	580	45	85	20	19.8	1.5	1	55	37 400	66 400	LRT 455520 S
50	NAST 50 R	NAST 50	635	50	90	20	19.8	1.5	1	60	38 900	71 700	LRT 506020 S

Note⁽¹⁾ Minimum allowable value of chamfer dimension r or r₁

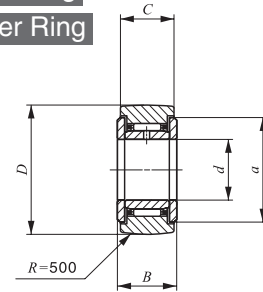
Remarks1. No oil hole is provided.

2. Not provided with prepacked grease. Perform proper lubrication for use.

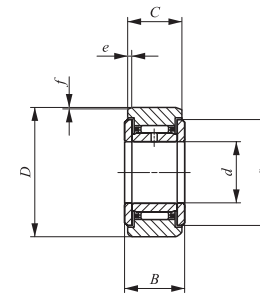
I
NAST
NART
NURT
CRY

ROLLER FOLLOWERS

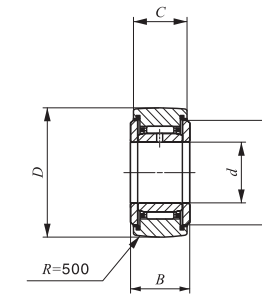
Separable Roller Followers, Shield Type **With Cage/With Inner Ring**
 Separable Roller Followers, Sealed Type **With Cage/With Inner Ring**



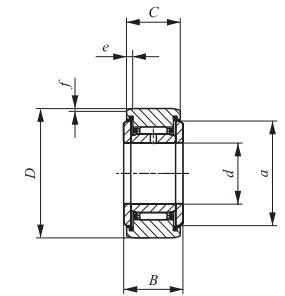
NAST...ZZR



NAST...ZZ



NAST...ZZUUR



NAST...ZZUU

Shaft dia. 6 – 50mm

Shaft dia. mm	Identification number				Mass (Ref.) g
	Shield type		Sealed type		
	Crowned outer ring	Cylindrical outer ring	Crowned outer ring	Cylindrical outer ring	
6	NAST 6 ZZR	NAST 6 ZZ	NAST 6 ZZUUR	NAST 6 ZZUU	24.5
8	NAST 8 ZZR	NAST 8 ZZ	NAST 8 ZZUUR	NAST 8 ZZUU	39
10	NAST 10 ZZR	NAST 10 ZZ	NAST 10 ZZUUR	NAST 10 ZZUU	65
12	NAST 12 ZZR	NAST 12 ZZ	NAST 12 ZZUUR	NAST 12 ZZUU	75
15	NAST 15 ZZR	NAST 15 ZZ	NAST 15 ZZUUR	NAST 15 ZZUU	83
17	NAST 17 ZZR	NAST 17 ZZ	NAST 17 ZZUUR	NAST 17 ZZUU	135
20	NAST 20 ZZR	NAST 20 ZZ	NAST 20 ZZUUR	NAST 20 ZZUU	195
25	NAST 25 ZZR	NAST 25 ZZ	NAST 25 ZZUUR	NAST 25 ZZUU	225
30	NAST 30 ZZR	NAST 30 ZZ	NAST 30 ZZUUR	NAST 30 ZZUU	400
35	NAST 35 ZZR	NAST 35 ZZ	NAST 35 ZZUUR	NAST 35 ZZUU	550
40	NAST 40 ZZR	NAST 40 ZZ	NAST 40 ZZUUR	NAST 40 ZZUU	710
45	NAST 45 ZZR	NAST 45 ZZ	NAST 45 ZZUUR	NAST 45 ZZUU	760
50	NAST 50 ZZR	NAST 50 ZZ	NAST 50 ZZUUR	NAST 50 ZZUU	830

Remarks1. The inner ring has an oil hole.
 2. The sealed type is provided with prepacked grease. The shield type is not provided with prepacked grease. Perform proper lubrication for use.

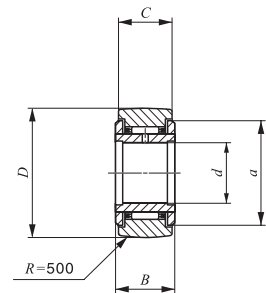
Boundary dimensions mm							Basic dynamic load rating C N	Basic static load rating C ₀ N
d	D	B	C	a	e	f		
6	19	14	13.8	14	2.5	0.8	4 160	4 550
8	24	14	13.8	17.5	2.5	0.8	5 650	5 890
10	30	16	15.8	23.5	2.5	0.8	9 790	9 680
12	32	16	15.8	25.5	2.5	0.8	10 500	10 900
15	35	16	15.8	29	2.5	0.8	12 400	14 300
17	40	20	19.8	32.5	3	1	17 600	20 900
20	47	20	19.8	38	3	1	19 400	24 500
25	52	20	19.8	43	3	1	20 800	28 400
30	62	25	24.8	50.5	4	1.2	30 500	45 400
35	72	25	24.8	53.5	4	1.2	32 400	50 600
40	80	26	25.8	61.5	4	1.2	35 900	61 100
45	85	26	25.8	66.5	4	1.2	37 400	66 400
50	90	26	25.8	76	4	1.2	38 900	71 700

I
 NAST
 NURT
 CRY

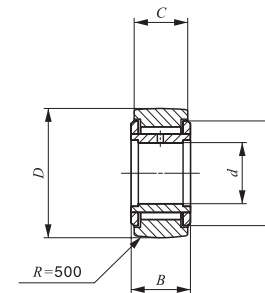
ROLLER FOLLOWERS

Non-separable Roller Followers · With Cage/With Inner Ring

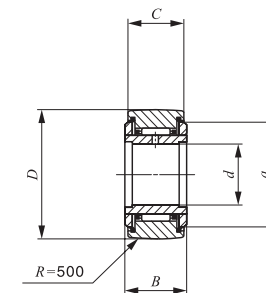
High carbon steel made Full Complement Type/With Inner Ring



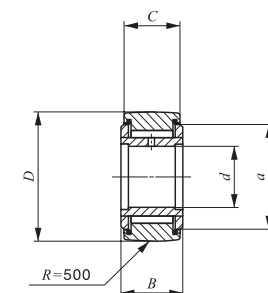
NART...R



NART...VR



NART...UUR



NART...VUUR

Shaft dia. 5 – 40mm

Shaft dia. mm	Identification number				Mass (Ref.) g
	Shield type		Sealed type		
	With cage	Full complement	With cage	Full complement	
5	NART 5 R	—	NART 5 UUR	—	14.5
	—	NART 5 VR	—	NART 5 VUUR	15.1
6	NART 6 R	—	NART 6 UUR	—	20.5
	—	NART 6 VR	—	NART 6 VUUR	21.5
8	NART 8 R	—	NART 8 UUR	—	41.5
	—	NART 8 VR	—	NART 8 VUUR	42.5
10	NART 10 R	—	NART 10 UUR	—	64.5
	—	NART 10 VR	—	NART 10 VUUR	66.5
12	NART 12 R	—	NART 12 UUR	—	71
	—	NART 12 VR	—	NART 12 VUUR	73
15	NART 15 R	—	NART 15 UUR	—	102
	—	NART 15 VR	—	NART 15 VUUR	106
17	NART 17 R	—	NART 17 UUR	—	149
	—	NART 17 VR	—	NART 17 VUUR	155
20	NART 20 R	—	NART 20 UUR	—	250
	—	NART 20 VR	—	NART 20 VUUR	255
25	NART 25 R	—	NART 25 UUR	—	285
	—	NART 25 VR	—	NART 25 VUUR	295
30	NART 30 R	—	NART 30 UUR	—	470
	—	NART 30 VR	—	NART 30 VUUR	485
35	NART 35 R	—	NART 35 UUR	—	640
	—	NART 35 VR	—	NART 35 VUUR	655
40	NART 40 R	—	NART 40 UUR	—	845
	—	NART 40 VR	—	NART 40 VUUR	865

Remarks1. The inner ring has an oil hole.
2. The sealed type is provided with prepacked grease. The shield type is not provided with prepacked grease. Perform proper lubrication for use.

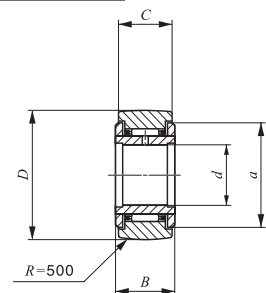
Boundary dimensions mm					Basic dynamic load rating C N	Basic static load rating C ₀ N	Maximum allowable static load N
d	D	B	C	a			
5	16	12	11	12	3 650	3 680	3 680
5	16	12	11	12	6 810	8 370	7 310
6	19	12	11	14	4 250	4 740	4 740
6	19	12	11	14	7 690	10 300	10 300
8	24	15	14	17.5	5 640	5 900	5 900
8	24	15	14	17.5	11 800	15 600	15 600
10	30	15	14	23.5	8 030	7 540	7 540
10	30	15	14	23.5	15 600	18 100	17 500
12	32	15	14	25.5	8 580	8 470	8 470
12	32	15	14	25.5	16 800	20 500	18 600
15	35	19	18	29	13 700	16 400	16 400
15	35	19	18	29	25 200	36 400	24 000
17	40	21	20	32.5	17 600	21 000	21 000
17	40	21	20	32.5	32 000	46 300	33 100
20	47	25	24	38	23 000	30 700	30 700
20	47	25	24	38	41 600	67 300	67 300
25	52	25	24	43	24 700	35 400	35 400
25	52	25	24	43	45 500	79 100	79 100
30	62	29	28	50.5	33 600	51 400	51 400
30	62	29	28	50.5	59 900	110 000	92 500
35	72	29	28	53.5	35 700	57 400	57 400
35	72	29	28	53.5	63 100	121 000	121 000
40	80	32	30	61.5	44 900	81 500	81 500
40	80	32	30	61.5	76 300	164 000	164 000

I
NART
NURT
CRY

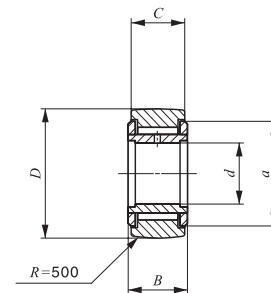
ROLLER FOLLOWERS

Non-separable Roller Followers · With Cage/With Inner Ring

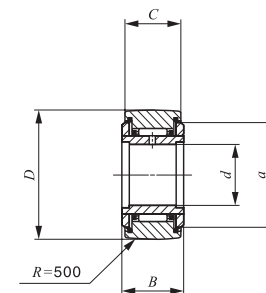
High carbon steel made Full Complement Type/With Inner Ring



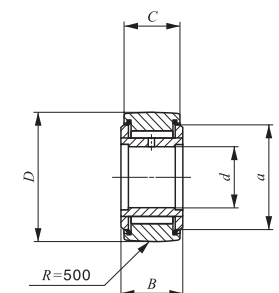
NART...R



NART...VR



NART...UUR



NART...VUUR

Shaft dia. 45 – 50mm

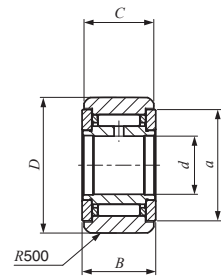
Shaft dia. mm	Identification number				Mass (Ref.) g
	Shield type Crowned outer ring		Sealed type Crowned outer ring		
	With cage	Full complement	With cage	Full complement	
45	NART 45 R	—	NART 45 UUR	—	915
	—	NART 45 VR	—	NART 45 VUUR	935
50	NART 50 R	—	NART 50 UUR	—	980
	—	NART 50 VR	—	NART 50 VUUR	1 010

Remarks1. The inner ring has an oil hole.
2. The sealed type is provided with prepacked grease. The shield type is not provided with prepacked grease. Perform proper lubrication for use.

Boundary dimensions mm					Basic dynamic load rating C N	Basic static load rating C ₀ N	Maximum allowable static load N
d	D	B	C	a			
45	85	32	30	66.5	46 800	88 600	88 600
45	85	32	30	66.5	80 300	181 000	181 000
50	90	32	30	76	48 600	95 600	95 600
50	90	32	30	76	84 300	198 000	198 000

I
NAST
NART
NURT
CRY

Non-separable Roller Followers · Stainless Steel Made **With Cage/With Inner Ring**

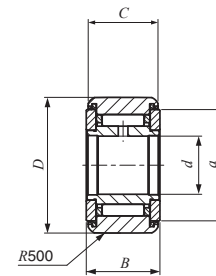


NART ... FR

Shaft dia. 5 – 30mm

Shaft dia. mm	Identification number		Mass (Ref.) g	Boundary dimensions mm				
	Shield type	Sealed type		<i>d</i>	<i>D</i>	<i>B</i>	<i>C</i>	<i>a</i>
5	NART 5 FR	NART 5 FUUR	13	5	16	12	11	12
6	NART 6 FR	NART 6 FUUR	19	6	19	12	11	14
8	NART 8 FR	NART 8 FUUR	39	8	24	15	14	17.5
10	NART 10 FR	NART 10 FUUR	61	10	30	15	14	22.5
12	NART 12 FR	NART 12 FUUR	67	12	32	15	14	25.5
15	NART 15 FR	NART 15 FUUR	99	15	35	19	18	27.5
17	NART 17 FR	NART 17 FUUR	146	17	40	21	20	31
20	NART 20 FR	NART 20 FUUR	241	20	47	25	24	36.5
25	NART 25 FR	NART 25 FUUR	269	25	52	25	24	43
30	NART 30 FR	NART 30 FUUR	447	30	62	29	28	50

Remarks1. The inner ring has an oil hole.
2. The sealed type is provided with prepacked grease. The shield type is not provided with prepacked grease. Perform proper lubrication for use.

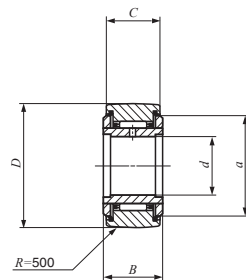


NART ... FUUR

Basic dynamic load rating <i>C</i> N	Basic static load rating <i>C</i> ₀ N	Maximum allowable static load N
2 930	2 920	2 920
3 400	3 790	3 790
4 340	5 510	5 510
6 330	7 830	7 830
6 510	8 400	8 400
9 620	14 700	14 700
11 800	20 200	20 200
16 500	27 700	27 700
19 800	28 300	28 300
26 900	41 200	41 200

I
NAST
NART
NURT
CRY

C-Lube Roller Followers **With Cage/With Inner Ring**



Shaft dia. 5 – 20mm

NART ... UUR/SG

Shaft dia. mm	Identification number Sealed type	Mass (Ref.) g	Boundary dimensions mm				
			<i>d</i>	<i>D</i>	<i>B</i>	<i>C</i>	<i>a</i>
5	NART 5 UUR / SG	14.5	5	16	12	11	12
6	NART 6 UUR / SG	20.5	6	19	12	11	14
8	NART 8 UUR / SG	41.5	8	24	15	14	17.5
10	NART 10 UUR / SG	64.5	10	30	15	14	23.5
12	NART 12 UUR / SG	71	12	32	15	14	25.5
15	NART 15 UUR / SG	102	15	35	19	18	29
17	NART 17 UUR / SG	149	17	40	21	20	32.5
20	NART 20 UUR / SG	250	20	47	25	24	38

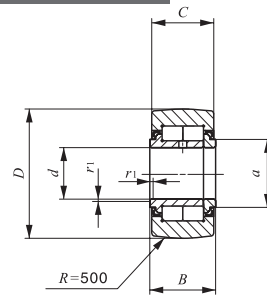
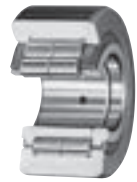
Remark This bearing cannot be re-lubricated as thermosetting solid-type lubricant C-Lube fills its inner space.

Basic dynamic load rating <i>C</i> N	Basic static load rating <i>C</i> ₀ N	Maximum allowable static load N
3 650	3 680	3 680
4 250	4 740	4 740
5 640	5 900	5 900
8 030	7 540	7 540
8 580	8 470	8 470
13 700	16 400	16 400
17 600	21 000	21 000
23 000	30 700	30 700

I
NAST
NART
NURT
CRY

ROLLER FOLLOWERS

Cylindrical Roller Followers Full Complement Type/With Inner Ring

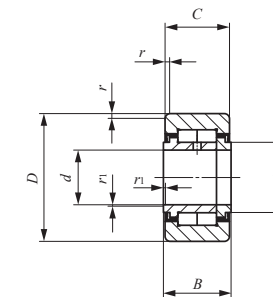


NURT...R

Shaft dia. 15 – 50mm

Shaft dia. mm	Identification number		Mass (Ref.) g	Boundary dimensions mm					
	Crowned outer ring	Cylindrical outer ring		d	D	B	C	a	r _s min ⁽¹⁾
15	NURT 15 R	NURT 15	100	15	35	19	18	20	0.6
	NURT 15-1 R	NURT 15-1	160	15	42	19	18	20	0.6
17	NURT 17 R	NURT 17	147	17	40	21	20	22	1
	NURT 17-1 R	NURT 17-1	222	17	47	21	20	22	1
20	NURT 20 R	NURT 20	245	20	47	25	24	27	1
	NURT 20-1 R	NURT 20-1	321	20	52	25	24	27	1
25	NURT 25 R	NURT 25	281	25	52	25	24	31	1
	NURT 25-1 R	NURT 25-1	450	25	62	25	24	31	1
30	NURT 30 R	NURT 30	466	30	62	29	28	38	1
	NURT 30-1 R	NURT 30-1	697	30	72	29	28	38	1
35	NURT 35 R	NURT 35	630	35	72	29	28	44	1
	NURT 35-1 R	NURT 35-1	840	35	80	29	28	44	1
40	NURT 40 R	NURT 40	817	40	80	32	30	49	1
	NURT 40-1 R	NURT 40-1	1 130	40	90	32	30	49	1
45	NURT 45 R	NURT 45	883	45	85	32	30	53	1
	NURT 45-1 R	NURT 45-1	1 400	45	100	32	30	53	1
50	NURT 50 R	NURT 50	950	50	90	32	30	58	1
	NURT 50-1 R	NURT 50-1	1 690	50	110	32	30	58	1

Note⁽¹⁾ Minimum allowable value of chamfer dimension r or r₁
 Remarks1. The inner ring has an oil hole.
 2. Provided with prepacked grease.



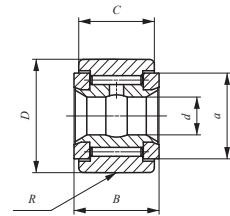
NURT

r _{1s} min ⁽¹⁾	Basic dynamic load rating C N	Basic static load rating C ₀ N	Maximum allowable static load N
0.3	23 400	27 300	11 800
0.3	23 400	27 300	27 300
0.3	25 200	30 900	20 300
0.3	25 200	30 900	30 900
0.3	38 900	49 000	27 200
0.3	38 900	49 000	49 000
0.3	43 100	58 100	30 000
0.3	43 100	58 100	58 100
0.3	58 200	75 300	35 200
0.3	58 200	75 300	75 300
0.6	63 900	88 800	57 000
0.6	63 900	88 800	88 800
0.6	86 500	122 000	75 300
0.6	86 500	122 000	122 000
0.6	91 500	135 000	78 700
0.6	91 500	135 000	135 000
0.6	96 300	148 000	82 100
0.6	96 300	148 000	148 000

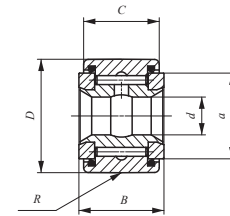
I
 NAST
 NURT
 CRY

ROLLER FOLLOWERS

Non-separable Roller Followers, Inch Series **Full Complement Type / With Inner Ring**



CRY...VR



CRY...VUUR

Shaft dia. 6.350 – 31.750mm

Shaft dia. mm (inch)	Identification number		Mass (Ref.) g	Boundary dimensions mm(inch)			
	Shield type Crown outer ring	Sealed type Crowned outer ring		d	D	B	C
6.350 (1/4)	CRY 12 VR	CRY 12 VUUR	24	6.350 (1/4)	19.050 (3/4)	14.288(0.5625)	12.700 (1/2)
	CRY 14 VR	CRY 14 VUUR	34	6.350 (1/4)	22.225 (7/8)	14.288(0.5625)	12.700 (1/2)
7.938 (5/16)	CRY 16 VR	CRY 16 VUUR	56	7.938 (5/16)	25.400 (1)	17.463(0.6875)	15.875 (5/8)
	CRY 18 VR	CRY 18 VUUR	72	7.938 (5/16)	28.575 (1 1/8)	17.463(0.6875)	15.875 (5/8)
9.525 (3/8)	CRY 20 VR	CRY 20 VUUR	103	9.525 (3/8)	31.750 (1 1/4)	20.638(0.8125)	19.050 (3/4)
	CRY 22 VR	CRY 22 VUUR	128	9.525 (3/8)	34.925 (1 3/8)	20.638(0.8125)	19.050 (3/4)
11.112 (7/16)	CRY 24 VR	CRY 24 VUUR	176	11.112 (7/16)	38.100 (1 1/2)	23.813(0.9375)	22.225 (7/8)
	CRY 26 VR	CRY 26 VUUR	210	11.112 (7/16)	41.275 (1 5/8)	23.813(0.9375)	22.225 (7/8)
12.700 (1/2)	CRY 28 VR	CRY 28 VUUR	276	12.700 (1/2)	44.450 (1 3/4)	26.988(1.0625)	25.400 (1)
	CRY 30 VR	CRY 30 VUUR	321	12.700 (1/2)	47.625 (1 7/8)	26.988(1.0625)	25.400 (1)
15.875 (5/8)	CRY 32 VR	CRY 32 VUUR	442	15.875 (5/8)	50.800 (2)	33.338(1.3125)	31.750 (1 1/4)
	CRY 36 VR	CRY 36 VUUR	575	15.875 (5/8)	57.150 (2 1/4)	33.338(1.3125)	31.750 (1 1/4)
19.050 (3/4)	CRY 40 VR	CRY 40 VUUR	835	19.050 (3/4)	63.500 (2 1/2)	39.688(1.5625)	38.100 (1 1/2)
	CRY 44 VR	CRY 44 VUUR	1 031	19.050 (3/4)	69.850 (2 3/4)	39.688(1.5625)	38.100 (1 1/2)
25.400 (1)	CRY 48 VR	CRY 48 VUUR	1 370	25.400 (1)	76.200 (3)	46.038(1.8125)	44.450 (1 3/4)
	CRY 52 VR	CRY 52 VUUR	1 640	25.400 (1)	82.550 (3 1/4)	46.038(1.8125)	44.450 (1 3/4)
28.575 (1 1/8)	CRY 56 VR	CRY 56 VUUR	2 160	28.575 (1 1/8)	88.900 (3 1/2)	52.388(2.0625)	50.800 (2)
31.750 (1 1/4)	CRY 64 VR	CRY 64 VUUR	3 190	31.750 (1 1/4)	101.600 (4)	58.738(2.3125)	57.150 (2 1/4)

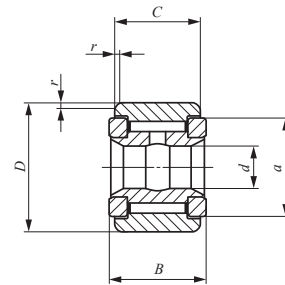
Remarks1. The inner ring has an oil groove and an oil hole.
2. Provided with prepacked grease.

a	R	Shaft dia. mm						Basic dynamic load rating C	Basic static load rating C ₀
		Push fit		Drive fit		Press fit			
		Min.	Max.	Min.	Max.	Min.	Max.	N	N
14.4(0.567)	250 (10)	6.332	6.342	6.348	6.358	6.353	6.363	8 710	12 300
14.4(0.567)	250 (10)	6.332	6.342	6.348	6.358	6.353	6.363	8 710	12 300
19.6(0.772)	300 (12)	7.920	7.930	7.935	7.945	7.940	7.950	13 100	22 700
19.6(0.772)	300 (12)	7.920	7.930	7.935	7.945	7.940	7.950	13 100	22 700
25.0(0.984)	360 (14)	9.507	9.517	9.523	9.533	9.528	9.538	23 600	31 700
25.0(0.984)	360 (14)	9.507	9.517	9.523	9.533	9.528	9.538	23 600	31 700
28.8(1.134)	500 (20)	11.095	11.105	11.110	11.120	11.115	11.125	28 200	40 100
28.8(1.134)	500 (20)	11.095	11.105	11.110	11.120	11.115	11.125	28 200	40 100
32.7(1.287)	500 (20)	12.682	12.692	12.698	12.708	12.708	12.718	35 300	55 600
32.7(1.287)	500 (20)	12.682	12.692	12.698	12.708	12.708	12.718	35 300	55 600
36.0(1.417)	600 (24)	15.857	15.867	15.873	15.883	15.883	15.893	45 700	80 600
36.0(1.417)	600 (24)	15.857	15.867	15.873	15.883	15.883	15.893	45 700	80 600
43.3(1.705)	760 (30)	19.032	19.042	19.048	19.058	19.058	19.068	61 400	116 000
43.3(1.705)	760 (30)	19.032	19.042	19.048	19.058	19.058	19.068	61 400	116 000
54.0(2.125)	760 (30)	25.377	25.390	25.397	25.410	25.408	25.420	77 600	172 000
54.0(2.125)	760 (30)	25.377	25.390	25.397	25.410	25.408	25.420	77 600	172 000
61.9(2.437)	760 (30)	28.522	28.565	28.572	28.585	28.583	28.595	111 000	239 000
71.0(2.797)	760 (30)	31.727	31.740	31.747	31.760	31.758	31.770	142 000	317 000

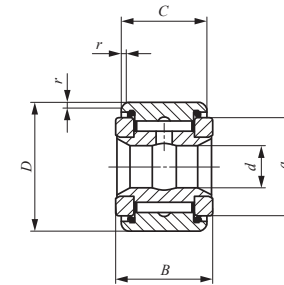
I
NAST
NURT
CRY

ROLLER FOLLOWERS

Non-separable Roller Followers, Inch Series Full Complement Type /With Inner Ring



CRY...V



CRY...VUU

Shaft dia. 6.350 – 31.750mm

Shaft dia. mm (inch)	Identification number		Mass (Ref.) g	Boundary dimensions mm(inch)			
	Shield type Cylindrical outer ring	Sealed type Cylindrical outer ring		d	D	B	C
6.350 (1/4)	CRY 12 V	CRY 12 VUU	24	6.350 (1/4)	19.050 (3/4)	14.288(0.5625)	12.700 (1/2)
	CRY 14 V	CRY 14 VUU	34	6.350 (1/4)	22.225 (7/8)	14.288(0.5625)	12.700 (1/2)
7.938 (5/16)	CRY 16 V	CRY 16 VUU	56	7.938 (5/16)	25.400 (1)	17.463(0.6875)	15.875 (5/8)
	CRY 18 V	CRY 18 VUU	72	7.938 (5/16)	28.575 (1 1/8)	17.463(0.6875)	15.875 (5/8)
9.525 (3/8)	CRY 20 V	CRY 20 VUU	103	9.525 (3/8)	31.750 (1 1/4)	20.638(0.8125)	19.050 (3/4)
	CRY 22 V	CRY 22 VUU	128	9.525 (3/8)	34.925 (1 3/8)	20.638(0.8125)	19.050 (3/4)
11.112 (7/16)	CRY 24 V	CRY 24 VUU	176	11.112 (7/16)	38.100 (1 1/2)	23.813(0.9375)	22.225 (7/8)
	CRY 26 V	CRY 26 VUU	210	11.112 (7/16)	41.275 (1 5/8)	23.813(0.9375)	22.225 (7/8)
12.700 (1/2)	CRY 28 V	CRY 28 VUU	276	12.700 (1/2)	44.450 (1 3/4)	26.988(1.0625)	25.400 (1)
	CRY 30 V	CRY 30 VUU	321	12.700 (1/2)	47.625 (1 7/8)	26.988(1.0625)	25.400 (1)
15.875 (5/8)	CRY 32 V	CRY 32 VUU	442	15.875 (5/8)	50.800 (2)	33.338(1.3125)	31.750 (1 1/4)
	CRY 36 V	CRY 36 VUU	575	15.875 (5/8)	57.150 (2 1/4)	33.338(1.3125)	31.750 (1 1/4)
19.050 (3/4)	CRY 40 V	CRY 40 VUU	835	19.050 (3/4)	63.500 (2 1/2)	39.688(1.5625)	38.100 (1 1/2)
	CRY 44 V	CRY 44 VUU	1 031	19.050 (3/4)	69.850 (2 3/4)	39.688(1.5625)	38.100 (1 1/2)
25.400 (1)	CRY 48 V	CRY 48 VUU	1 370	25.400 (1)	76.200 (3)	46.038(1.8125)	44.450 (1 3/4)
	CRY 52 V	CRY 52 VUU	1 640	25.400 (1)	82.550 (3 1/4)	46.038(1.8125)	44.450 (1 3/4)
28.575 (1 1/8)	CRY 56 V	CRY 56 VUU	2 160	28.575 (1 1/8)	88.900 (3 1/2)	52.388(2.0625)	50.800 (2)
31.750 (1 1/4)	CRY 64 V	CRY 64 VUU	3 190	31.750 (1 1/4)	101.600 (4)	58.738(2.3125)	57.150 (2 1/4)

Remarks1. The inner ring has an oil groove and an oil hole.
2. Provided with prepacked grease.

a	r	Shaft dia. mm						Basic dynamic load rating C	Basic static load rating C ₀
		Push fit		Drive fit		Press fit			
		Min.	Max.	Min.	Max.	Min.	Max.	N	N
14.4(0.567)	0.794 (1/32)	6.332	6.342	6.348	6.358	6.353	6.363	8 710	12 300
		6.332	6.342	6.348	6.358	6.353	6.363		
19.6(0.772)	1.191 (3/64)	7.920	7.930	7.935	7.945	7.940	7.950	13 100	22 700
		7.920	7.930	7.935	7.945	7.940	7.950		
25.0(0.984)	1.588 (1/16)	9.507	9.517	9.523	9.533	9.528	9.538	23 600	31 700
		9.507	9.517	9.523	9.533	9.528	9.538		
28.8(1.134)	1.588 (1/16)	11.095	11.105	11.110	11.120	11.115	11.125	28 200	40 100
		11.095	11.105	11.110	11.120	11.115	11.125		
32.7(1.287)	1.588 (1/16)	12.682	12.692	12.698	12.708	12.708	12.718	35 300	55 600
		12.682	12.692	12.698	12.708	12.708	12.718		
36.0(1.417)	1.588 (1/16)	15.857	15.867	15.873	15.883	15.883	15.893	45 700	80 600
		15.857	15.867	15.873	15.883	15.883	15.893		
43.3(1.705)	2.381 (3/32)	19.032	19.042	19.048	19.058	19.058	19.068	61 400	116 000
		19.032	19.042	19.048	19.058	19.058	19.068		
54.0(2.125)	2.381 (3/32)	25.377	25.390	25.397	25.410	25.408	25.420	77 600	172 000
		25.377	25.390	25.397	25.410	25.408	25.420		
61.9(2.437)	2.381 (3/32)	28.522	28.565	28.572	28.585	28.583	28.595	111 000	239 000
71.0(2.797)	2.381 (3/32)	31.727	31.740	31.747	31.760	31.758	31.770	142 000	317 000

I
NAST
NURT
CRY

CROSSED ROLLER BEARINGS

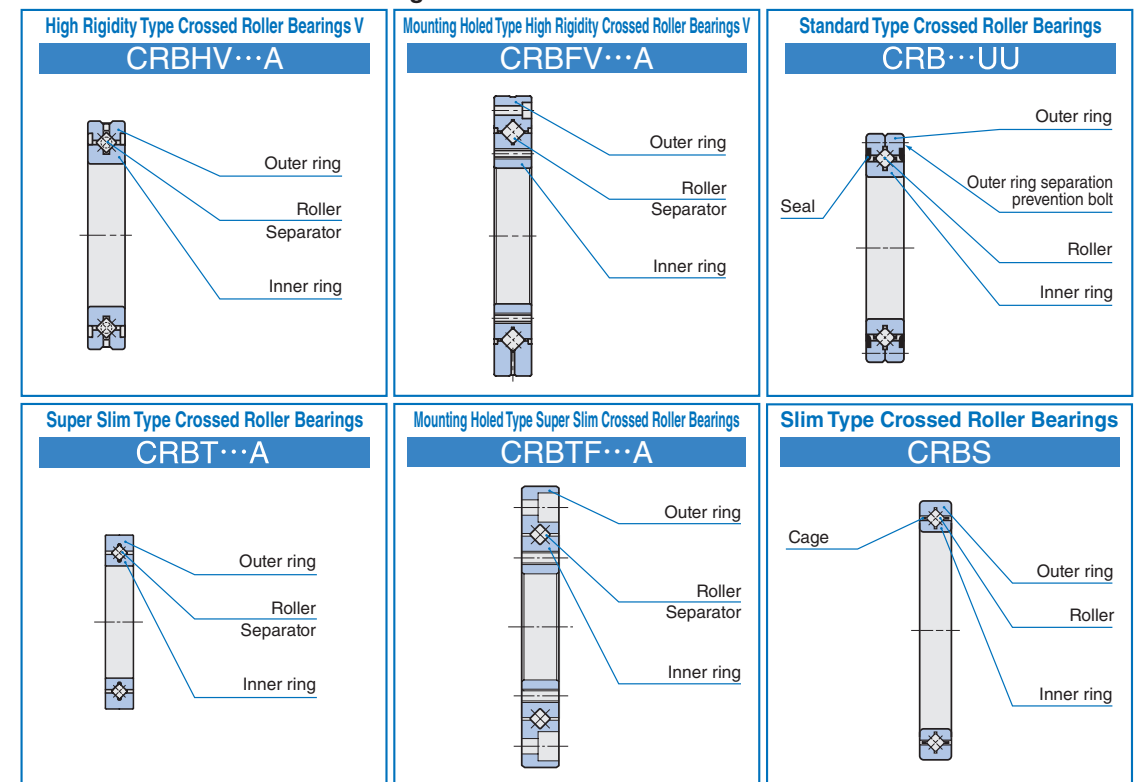
- High Rigidity Type Crossed Roller Bearings V
- Mounting Holed Type High Rigidity Crossed Roller Bearings V
- Standard Type Crossed Roller Bearings
- Super Slim Type Crossed Roller Bearings
- Mounting Holed Type Super Slim Crossed Roller Bearings
- Slim Type Crossed Roller Bearings



Structure and Features

IKO Crossed Roller Bearings are compact bearings with their rollers alternately crossed at right angles to each other between inner and outer rings. They can take loads from any directions at the same time such as radial, thrust and moment loads. The rollers make line-contact with raceway surfaces, and, therefore, elastic deformation due to bearing loads is very small. These bearings are widely used in the rotating parts of industrial robots, machine tools, medical equipment, etc., which require compactness, high rigidity and high rotational accuracy. In addition, bearings made of stainless steel or those with inner and outer rings provided with mounting holes are also available on request. Please contact IKO.

Structure of Crossed Roller Bearings



J
CRBHV
CRBFV
CRB(C)
CRBT
CRBTF
CRBS

Crossed Roller Bearings are available in the types shown in Table 1.

Table 1 Crossed Roller Bearing Type

Type		With Cage	With Separator	Full Complement
High Rigidity Type Crossed Roller Bearings CRBHV	Open type	—	CRBHV···A	—
	Sealed type	—	CRBHV···AUU	—
Mounting Holed Type High Rigidity Crossed Roller Bearings V CRBFV	Open type	—	CRBFV···A	—
	Sealed type	—	CRBFV···AUU	—
Standard Type Crossed Roller Bearings CRBC, CRB	Open type	CRBC	—	CRB
	Sealed type	CRBC···UU	—	CRB···UU
Super Slim Type Crossed Roller Bearings CRBT	Open type	—	CRBT···A	—
Mounting Holed Type Super Slim Crossed Roller Bearings CRBTF	Open type	—	CRBTF···A	—
Slim Type Crossed Roller Bearings CRBS	Open type	CRBS	—	CRBS···V
	Sealed type	—	CRBS···AUU	CRBS···VUU

High Rigidity Type Crossed Roller Bearings V

Both inner and outer rings have a solid one-piece construction. Therefore, high accuracy and high rigidity are achieved, and mounting errors can be minimized. As separators are incorporated between the cylindrical rollers for smooth rotation, these bearings are suitable for applications where rotational speed is comparatively high.

Mounting Holed Type High Rigidity Crossed Roller Bearings

Mounting holes are prepared on outer ring and inner ring providing easy mounting together with high rigidity and high accuracy.

Standard Type Crossed Roller Bearings

The outer ring is made of two split pieces, which are bolted together to prevent separation during transportation or mounting. So, handling is easy.

Super Slim Type Crossed Roller Bearings

This Type is extremely compact bearing having 5.5mm of sectional height and 5mm of width. Separators are incorporated between Cylindrical rollers for smooth rotation. These compactness, lightness and smoothness contribute downsizing of the machine and saving driving power.

Mounting Holed Type Super Slim Crossed Roller Bearings

These bearings are extremely compact and lightweight at a width of just 5 mm, with both outer and inner rings integrated (non-separable), and mounting holes in the rings for easy mounting to equipment.

Slim Type Crossed Roller Bearings

These bearings are slim bearings having a small outside diameter, in comparison with the bore diameter, and a narrow width. The type with cage and the type with separator provide smooth rotation and are suitable for applications where rotational speed is comparatively high.

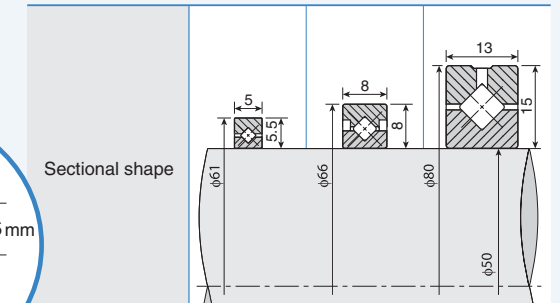
Features of Super Slim Type Crossed Roller Bearing CRBT

The world's thinnest roller type! Very low cross sectional height of 5.5 mm

The cross sectional height is reduced by 69% in comparison with CRBS, which was the thinnest before (bearing bore diameter 50 mm). The width is also as small as 5 mm and the cross sectional area is reduced by 43% in comparison with conventional products.



Comparison of bearing bore diameter 50 mm



Series	Super Slim CRBT505A	Slim CRBS508	High rigidity CRBHV5013A
Outer diameter mm	61	66	80
Width mm	5	8	13
Sectional height mm	5.5	8	15
C	N	2280	4900
C ₀	N	3200	6170
Mass g	32.3	84	290
Compared with CRBHV	0.11	0.29	1.00
Compared with CRBS	0.38	1.00	3.45

Significant weight saving by 38% in comparison with conventional types was realized

Weight reduction is thoroughly pursued. The mass ratio is 0.38 and significant weight saving was realized in comparison with conventional slim type CRBS (bearing bore diameter 50 mm).

Features of Mounting Holed Type Crossed Roller Bearings CRBFV, CRBTF

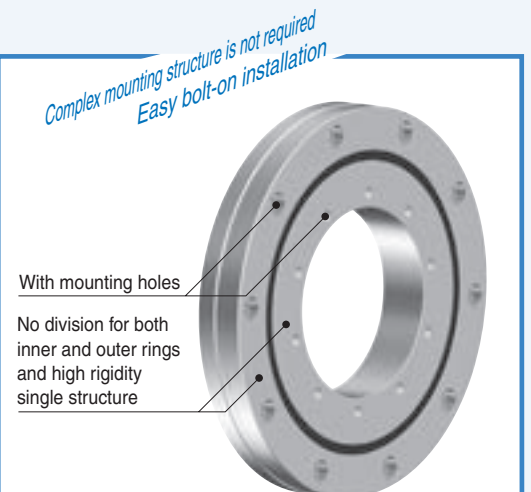
High rigidity and high accuracy

The single structure to reduce the mounting errors is adopted for both inner and outer rings. Further, mounting holes for direct fixing on mating mounting surface are available. So high rigidity and high accuracy guide can be easily realized, being less subject to the structure of the housing and the accuracy.

Contributing to miniaturization

It can be easily mounted to a device with bolts without need for housing and fixing plate, so surrounding parts of the bearing can be made compact.

Further, it allows for reduction of the number of parts and assembly processes, which contributes to miniaturization and weight saving of devices.



Single structure for both inner and outer rings!
Mounting Holed Type High Rigidity Crossed Roller Bearing V
Mounting Holed Type Super Slim Crossed Roller Bearings
CRBFV, CRBTF

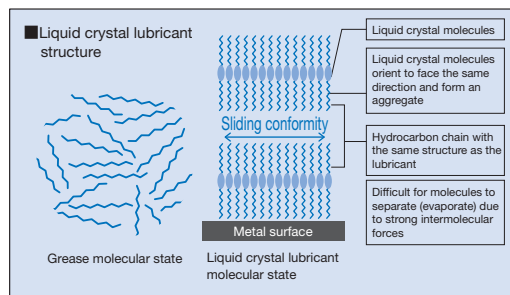
J

CRBHV
CRBFV
CRB(C)
CRBT
CRBTF
CRBS

LCL Crossed Roller Bearings

Neither grease nor oil World's first Liquid Crystal Lubricant

Liquid Crystal Lubricants are completely different from greases composed of base oils and thickeners. **These are composed only of liquid crystal compounds, forming a new type of lubricant never seen before.** Conventional grease base oils lubricate using dissimilar molecules, causing difficulties with adhesion to metal surfaces and evaporation. Liquid Crystal Lubricant forms molecular aggregates, improving adhesion to metal surfaces and minimizing evaporation. The Liquid Crystal Lubricant used in LCL Crossed Roller Bearings is the world's first Liquid Crystal Lubricant for bearings, achieving excellent lubrication functionality even under high contact pressure during rolling contact and succeeding in creating revolutionary new functions.



■ Features of LCL Crossed Roller Bearings

Superior load durability

Long-term durability exceeds 7 times that of fluorine grease at room temperature and atmospheric pressure.

Superior vacuum characteristics

The outgassing characteristics under high vacuum environments show excellent performance even at high temperatures. The durability in a vacuum environment shows results that are more than twice as positive as those of fluorine grease.

Minimizes lubricant evaporation

There is zero mass loss even at 100°C. Liquid Crystal Lubricants have no loss due to evaporation.

Low rotational torque

The rotational torque is lower than that of fluorine grease or lithium soap-based grease.



LCL Crossed Roller Bearings are individually manufactured to order. If other products prepacked with LCL are needed, please contact IKO.

Internal Structures and Shapes

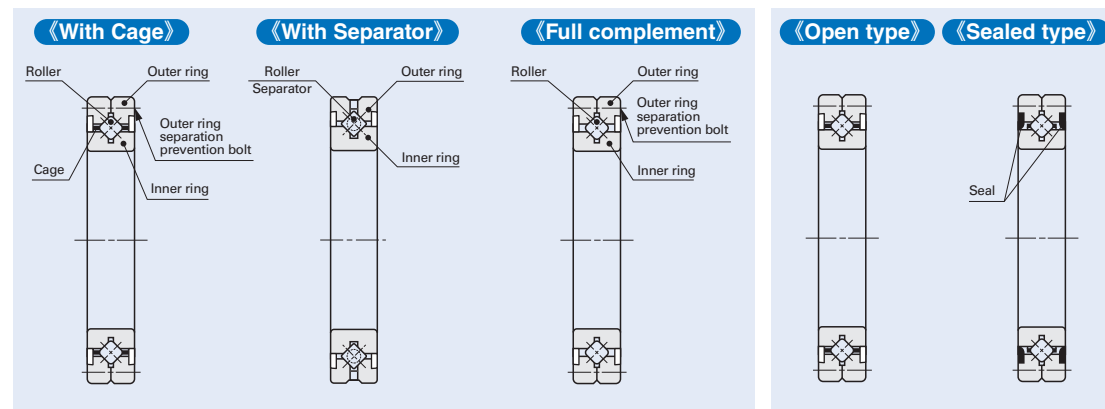
Various types are lined up in Crossed Roller Bearing series, including the type with cage, the type with separator, open type, sealed type, etc.

Roller guide method

Crossed Roller Bearings include the type with cage, type with separator and full complement type. The type with cage and the type with separator have a small coefficient of friction and are suitable for comparatively high speed rotations, while the full complement type is suitable for heavy load applications at low speed rotations.

Seal structure

Crossed Roller Bearings include the open type and sealed type. The sealed type bearing incorporates seals made of special synthetic rubber that have excellent sealing performance against dust and dirt penetration and grease leakage. However, excess grease may be discharged during initial operations.



Identification number

The identification number of Crossed Roller Bearings consists of a model code, dimensions, any supplemental codes and a classification symbol. Some examples are shown below.

Examples of identification number

	Model code	Dimensions	Supplemental code	Classification symbol
Example 1	CRBHV	150 25	UU C1	P6
Example 2	CRBC	150 25	UU C1	P6
Example 3	CRBT	30 5	C1	
Example 4	CRBS	150 8	UU C1	
Example 5	CRBFV	115 28	D UU C1	RP6

Model code	
CRBHV ...A	High Rigidity Type Crossed Roller Bearings V (With Separator)
CRBFV ...A	Mounting Holed Type High Rigidity Crossed Roller Bearings V (With Separator)
CRBC	Standard Type Crossed Roller Bearings (With Cage)
CRB	Standard Type Crossed Roller Bearings (Full complement)
CRBT ...A	Super Slim Type Crossed Roller Bearings (With Separator)
CRBTF ...A	Mounting Holed Type Super Slim Crossed Roller Bearings (With Separator)
CRBS	Slim Type Crossed Roller Bearings (With Cage)
CRBS ...A	Slim Type Crossed Roller Bearings (With Separator)
CRBS ...V	Slim Type Crossed Roller Bearings (Full complement)

Dimension	
The dimension indicates the bore diameter of the bearing. (unit : mm)	
The dimension indicates the bearing width. (unit : mm)	

Supplemental code - 1 ⁽¹⁾	
T	With female threaded mounting holes on the inner ring
No symbol	With counter-bored mounting holes on both inner ring and outer ring in the same direction.
D	With counter-bored mounting holes on both inner ring and outer ring in the opposite direction.

Note⁽¹⁾ Applicable to Mounting Holed Type Crossed Roller Bearings.
Note that with female threaded mounting holes on the inner ring (T) is only applicable for Mounting Holed Type Super Slim Crossed Roller Bearings.

Supplemental code - 2		
No symbol	Open type	For application, please see table 2.
UU	Sealed type	
U	One side sealed type	

Supplemental code - 3		
T1	: T1 clearance	For application, please see table 3.
C1	: C1 clearance	
C2	: C2 clearance	
No symbol	: Normal clearance	

Classification symbol	
No symbol	Accuracy class 0
P6	Accuracy class 6
P5	Accuracy class 5
P4	Accuracy class 4
P2	Accuracy class 2
RP6	Rotational accuracy class 6
RP5	Rotational accuracy class 5
RP4	Rotational accuracy class 4
RP2	Rotational accuracy class 2

For application, please see table 4.

Rotational accuracy class--classes specifying accuracy standards for only rotational accuracy (radial runout, axial runout).

Table 2 Seal Specification

Model code	No Symbol	UU	U
CRBHV ... A	○	○	—
CRBFV ... A	○	○	—
CRBC	○	○	○
CRB	○	○	○
CRBT ... A	○	—	—
CRBTF ... A	○	—	—
CRBS	○	—	—
CRBS ... A	—	○	○
CRBS ... V	○	○	○

Table 3 Clearance Specification

Model code	T1	C1	C2	No Symbol
CRBHV ... A	○	○	○	—
CRBFV ... A	○	○	○	—
CRBC	○	○	○	—
CRB	○	○	○	—
CRBT ... A	—	○	—	—
CRBTF ... A	—	○	—	—
CRBS	○	○	—	○
CRBS ... A	○	○	—	○
CRBS ... V	○	○	—	○

Table 4 Accuracy Class

Model code	No Symbol	P6 RP6	P5 RP5	P4 RP4	P2 RP2
CRBHV ... A	○	○	○	○	○
CRBFV ... A	○	○	○	○	○
CRBC	○	○	○	○	○
CRB	○	○	○	○	○
CRBT ... A	○	—	—	—	—
CRBTF ... A	○	—	—	—	—
CRBS	○	—	—	—	—
CRBS ... A	○	—	—	—	—
CRBS ... V	○	—	—	—	—

Dynamic Equivalent Load

The direction of basic dynamic load rating of Crossed Roller Bearing is the radial direction. When a load in any direction other than the direction of basic dynamic load rating or a complex load is applied, calculate the dynamic equivalent load to calculate the rating life.

$$P_r = X \left(F_r + \frac{2M}{D_{pw}} \right) + Y F_a \dots\dots\dots(1)$$

where, P_r : Dynamic equivalent radial load, N

F_r : Radial load, N

F_a : Axial load, N

M : Moment, N-mm

D_{pw} : Pitch circle diameter of roller set, mm

$$\left(D_{pw} \doteq \frac{d + D}{2} \right)$$

X : Radial load factor (Refer to Table 5.)

Y : Axial load factor (Refer to Table 5.)

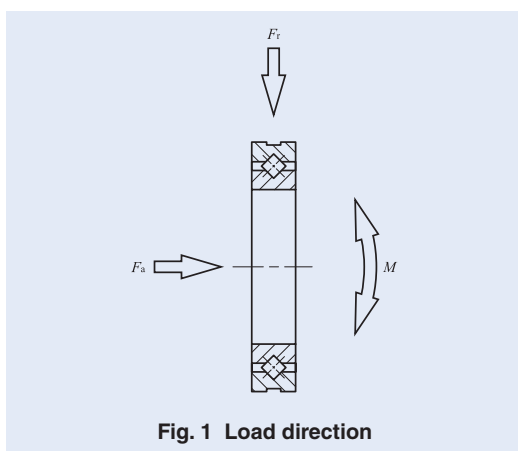


Fig. 1 Load direction

Table 5 Radial load factor and axial load factor

Conditions	X	Y
$\frac{F_a}{F_r + 2M/D_{pw}} \leq 1.5$	1	0.45
$\frac{F_a}{F_r + 2M/D_{pw}} > 1.5$	0.67	0.67

Static Equivalent Load

The direction of basic static load rating of Crossed Roller Bearing is the radial direction. When a load in any direction other than the direction of basic static load rating or a complex load is applied, calculate the static equivalent load to calculate the static safety factor.

$$P_{0r} = F_r + \frac{2M}{D_{pw}} + 0.44 F_a \dots\dots\dots(2)$$

where, P_{0r} : Static equivalent radial load, N

F_r : Radial load, N

F_a : Axial load, N

M : Moment, N-mm

D_{pw} : Pitch circle diameter of roller set, mm

$$\left(D_{pw} \doteq \frac{d + D}{2} \right)$$

Accuracy

The accuracy of Crossed Roller Bearings is shown in Table 6 and Table 7. However, Table 8 is applicable to Super Slim Type Crossed Roller Bearings and Mounting Holed Type Super Slim Crossed Roller Bearings, Table 9 is applicable to Slim Type

Crossed Roller Bearings, and Tables 10.1 and 10.2 are applicable to Mounting Holed Type High Rigidity Crossed Roller Bearings V. Bearings with special accuracy are also options. Please consult IKO.

Table 6 Tolerances and allowable values of inner rings and tolerances of outer ring width

unit: μm

Nominal bore diameter mm	d	$\Delta_{dmp}^{(1)}$ Single plane mean bore dia. deviation								Δ_{Bs} Deviation of a single inner ring width		$\Delta_{Cs}^{(2)}$ Deviation of a single outer ring width		K_{ia} Radial run-out of assembled bearing inner ring					S_{ia} Assembled bearing inner ring face run-out with raceway				
		Class 0 RP6-2		P6		P5		P4		High	Low	High	Low	Class 0	P6 RP6	P5 RP5	P4 RP4	P2 RP2	Class 0	P6 RP6	P5 RP5	P4 RP4	P2 RP2
		Over	Incl.	High	Low	High	Low	High	Low														
18	30	0	-10	0	-8	0	-6	0	-5	0	-75	0	-100	13	8	4	3	2.5	13	8	4	3	2.5
30	50	0	-12	0	-10	0	-8	0	-6	0	-75	0	-100	15	10	5	4	2.5	15	10	5	4	2.5
50	80	0	-15	0	-12	0	-9	0	-7	0	-75	0	-100	20	10	5	4	2.5	20	10	5	4	2.5
80	120	0	-20	0	-15	0	-10	0	-8	0	-75	0	-100	25	13	6	5	2.5	25	13	6	5	2.5
120	150	0	-25	0	-18	0	-13	0	-10	0	-100	0	-120	30	18	8	6	2.5	30	18	8	6	2.5
150	180	0	-25	0	-18	0	-13	0	-10	0	-100	0	-120	30	18	8	6	5	30	18	8	6	5
180	250	0	-30	0	-22	0	-15	0	-12	0	-100	0	-120	40	20	10	8	5	40	20	10	8	5
250	315	0	-35	0	-25	0	-18	—	—	0	-120	0	-150	50	25	13	10	7	50	25	13	10	7
315	400	0	-40	0	-30	0	-23	—	—	0	-150	0	-200	60	30	15	12	8	60	30	15	12	8
400	500	0	-45	0	-35	—	—	—	—	0	-150	0	-200	65	35	18	14	10	65	35	18	14	10
500	630	0	-50	0	-40	—	—	—	—	0	-150	0	-200	70	40	20	16	12	70	40	20	16	12
630	800	0	-75	—	—	—	—	—	—	0	-150	0	-200	80	50	25	20	15	80	50	25	20	15

Notes⁽¹⁾ For accuracy class P2 and other classes without a numerical description, the highest grade numerical value among the lower accuracy classes in the same nominal bore diameter range is applied.

⁽²⁾ For High Rigidity Type Crossed Roller Bearings V, the tolerances for deviation of a single inner ring width are applicable to those of a single outer ring width.

Remark The accuracy specified in this table is not applicable to Super Slim Type Crossed Roller Bearings, Mounting Holed Type Super Slim Crossed Roller Bearings, Slim Type Crossed Roller Bearings, and Mounting Holed Type High Rigidity Crossed Roller Bearings V.

Table 7 Tolerances and allowable values of outer ring

unit: μm

Nominal outside diameter mm	D	$\Delta_{Dmp}^{(1)}$ Single plane mean outside dia. deviation								K_{ea} Radial run-out of assembled bearing outer ring					S_{ea} Assembled bearing outer ring face run-out with raceway				
		Class 0 RP6-2		P6		P5		P4		Class 0	P6 RP6	P5 RP5	P4 ⁽²⁾ RP4	P2 ⁽²⁾ RP2	Class 0	P6 RP6	P5 RP5	P4 ⁽²⁾ RP4	P2 ⁽²⁾ RP2
		Over	Incl.	High	Low	High	Low	High	Low										
30	50	0	-11	0	-9	0	-7	0	-6	20	10	7	5	2.5	20	10	7	5	2.5
50	80	0	-13	0	-11	0	-9	0	-7	25	13	8	5	4	25	13	8	5	4
80	120	0	-15	0	-13	0	-10	0	-8	35	18	10	6	5	35	18	10	6	5
120	150	0	-18	0	-15	0	-11	0	-9	40	20	11	7	5	40	20	11	7	5
150	180	0	-25	0	-18	0	-13	0	-10	45	23	13	8	5	45	23	13	8	5
180	250	0	-30	0	-20	0	-15	0	-11	50	25	15	10	7	50	25	15	10	7
250	315	0	-35	0	-25	0	-18	0	-13	60	30	18	11	7	60	30	18	11	7
315	400	0	-40	0	-28	0	-20	—	—	70	35	20	—	—	70	35	20	—	—
400	500	0	-45	0	-33	0	-23	—	—	80	40	23	—	—	80	40	23	—	—
500	630	0	-50	0	-38	0	-28	—	—	100	50	25	—	—	100	50	25	—	—
630	800	0	-75	0	-45	—	—	—	—	120	60	30	—	—	120	60	30	—	—
800	1000	0	-100	0	-60	—	—	—	—	120	75	35	—	—	120	75	35	—	—
1000	1030	0	-125	—	—	—	—	—	—	120	75	35	—	—	120	75	35	—	—

Notes⁽¹⁾ For accuracy class P2 and other classes without a numerical description, the highest grade numerical value among the lower accuracy classes in the same nominal bore diameter range is applied.

⁽²⁾ P4 and P2 apply to High Rigidity Type Crossed Roller Bearings V. For Standard Type Crossed Roller Bearings, the tolerance values for P5 are applicable to P4 and P2.

Remark The accuracy specified in this table is not applicable to Super Slim Type Crossed Roller Bearings, Mounting Holed Type Super Slim Crossed Roller Bearings, Slim Type Crossed Roller Bearings, and Mounting Holed Type High Rigidity Crossed Roller Bearings V.

Table 8 Tolerances and allowable values of Super Slim Type Crossed Roller Bearings and Mounting Holed Type Super Slim Crossed Roller Bearings unit: μm

Table with 9 columns: d (Nominal bore diameter mm), Δdmp (Single plane mean bore dia. deviation), ΔDmp (Single plane mean outside dia. deviation), ΔBs and ΔCs (Deviations of a single inner ring width and outer ring width), Kia and Sia (Radial and axial run-out of assembled bearing inner ring), Kea and Sea (Radial and axial run-out of assembled bearing outer ring).

Remark The values in parentheses are for Mounting Holed Type Super Slim Crossed Roller Bearings.

Table 10.2 Tolerances and allowable values of outer rings of Mounting Holed Type High Rigidity Crossed Roller Bearings V unit: μm

Table with 19 columns: D (Nominal outside diameter mm), ΔDmp (Single plane mean outside dia. deviation), ΔCs (Deviation of a single outer ring width), Kea (Radial run-out of assembled bearing outer ring), Sea (Assembled bearing outer ring face run-out with raceway).

Table 9 Tolerances and allowable values of Slim Type Crossed Roller Bearings unit: μm

Table with 9 columns: d (Nominal bore diameter mm), Δdmp (Single plane mean bore dia. deviation), ΔDmp (Single plane mean outside dia. deviation), ΔBs and ΔCs (Deviations of a single inner ring width and outer ring width), Kia and Sia (Radial and axial run-out of assembled bearing inner ring), Kea and Sea (Radial and axial run-out of assembled bearing outer ring).

Clearance

The radial internal clearances of Crossed Roller Bearings are shown in Table 11.1. However, Table 11.2 is applicable to Super Slim Type Crossed Roller Bearings and Mounting Holed Type Super Slim Crossed Roller Bearings, Table 11.3 is applicable to Slim Type Crossed Roller Bearings, and Table 11.4 is applicable to Mounting Holed Type High Rigidity Crossed Roller Bearings V.

Table 11.2 Radial internal clearances of Super Slim Type Crossed Roller Bearings and Mounting Holed Type Super Slim Crossed Roller Bearings unit: μm

Table with 3 columns: d (Nominal bore diameter of bearing mm), Radial internal clearance C1 (Min., Max.).

Table 11.1 Radial internal clearances unit: μm

Table with 9 columns: d (Nominal bore diameter mm), Radial internal clearance (T1, C1, C2) (Min., Max.).

Remark Not applicable to Super Slim Type Crossed Roller Bearings, Mounting Holed Type Super Slim Crossed Roller Bearings, Slim Type Crossed Roller Bearings and Mounting Holed Type High Rigidity Crossed Roller Bearings V.

Table 11.3 Radial internal clearances of Slim Type Crossed Roller Bearings unit: μm

Table with 7 columns: d (Nominal bore diameter mm), Radial internal clearance (T1, C1, Normal) (Min., Max.).

Table 10.1 Tolerances and allowable values of inner rings of Mounting Holed Type High Rigidity Crossed Roller Bearings V unit: μm

Table with 19 columns: d (Nominal bore diameter mm), Δdmp (Single plane mean bore dia. deviation), ΔBs (Deviation of a single inner ring width), Kia (Radial run-out of assembled bearing inner ring), Sia (Assembled bearing inner ring face run-out with raceway).



Table 11.4 Radial internal clearances of Mounting Holed Type High Rigidity Crossed Roller Bearings V
unit: μm

Nominal bore diameter mm	Radial internal clearance							
	T1		C1		C2			
	Over	Incl.	Min.	Max.	Min.	Max.	Min.	Max.
—	20	—	10	0	0	10	10	20
20	25	—	10	0	0	10	10	20
25	35	—	10	0	0	10	10	25
35	65	—	10	0	0	15	15	30
65	80	—	10	0	0	15	15	35
80	95	—	15	0	0	15	15	35
95	110	—	15	0	0	20	20	45
110	125	—	15	0	0	20	20	50

Fit

The standard fits of Crossed Roller Bearings are shown in Table 12.1, and recommended fits for Slim Type Crossed Roller Bearings with normal clearances are shown in Table 12.2. For Super Slim Type Crossed Roller Bearings, it is recommended to use a slight interference fit adjusted to the actual measured dimensions. For large bearings, fit based on the actual measured dimensions of the bearings is recommended, and fit allowance should be chosen as small as possible in accordance with the tolerance class given in Table 12.1. When complex loads or shock loads are applied or when high rotational accuracy and rigidity of the bearing are required, it is recommended to use a slight interference fit adjusted to the actual measured dimensions for both inner and outer rings.

For the interference fit, the radial internal clearance after the fit decreases by approximately 70% to 90% of the interference amount. To avoid excessive pre-load due to fit, it is recommended to use a slight interference fit adjusted to the actual measured dimensions for both T1 and C1 clearances.

Table 12.1 Recommended fits for Crossed Roller Bearings under normal load

Radial internal clearance	Tolerance class			
	Inner ring rotating load		Outer ring rotating load	
	Shaft	Housing bore	Shaft	Housing bore
T1 clearance	g5	H7	g5	J7 ⁽¹⁾
C1 clearance	h5	H7	g5	J7 ⁽¹⁾
C2 clearance	j5	H7	g5	J7 ⁽¹⁾

Note⁽¹⁾ It is recommended that a slight interference fit adjusted to the actual measured dimensions of the bearing is used.

Table 12.2 Recommended fits for Slim Type Crossed Roller Bearings with normal clearances
(Dimensional tolerances of shaft and housing bore) unit: μm

Nominal bore diameter mm	Inner ring rotating load				Outer ring rotating load			
	Shaft		Housing bore		Shaft		Housing bore	
	High	Low	High	Low	High	Low	High	Low
50	+ 15	0	+ 13	0	— 15	— 30	— 13	— 25
60	+ 15	0	+ 13	0	— 15	— 30	— 13	— 25
70	+ 15	0	+ 15	0	— 15	— 30	— 15	— 30
80	+ 20	0	+ 15	0	— 20	— 40	— 15	— 30
90	+ 20	0	+ 15	0	— 20	— 40	— 15	— 30
100	+ 20	0	+ 15	0	— 20	— 40	— 15	— 30
110	+ 20	0	+ 20	0	— 20	— 40	— 20	— 40
120	+ 25	0	+ 20	0	— 25	— 50	— 20	— 40
130	+ 25	0	+ 25	0	— 25	— 50	— 25	— 50
140	+ 25	0	+ 25	0	— 25	— 50	— 25	— 50
150	+ 25	0	+ 25	0	— 25	— 50	— 25	— 50
160	+ 25	0	+ 25	0	— 25	— 50	— 25	— 50
170	+ 25	0	+ 30	0	— 25	— 50	— 30	— 60
180	+ 30	0	+ 30	0	— 30	— 60	— 30	— 60
190	+ 30	0	+ 30	0	— 30	— 60	— 30	— 60
200	+ 30	0	+ 30	0	— 30	— 60	— 30	— 60

Allowable rotational speed

Allowable rotational speeds of Crossed Roller Bearings are affected by mounting and operating conditions. The values in general operation are shown in Table 13.

Table 13 $d_m n$ values⁽¹⁾ of Crossed Roller Bearings

Type	Lubricant	
	Grease	Oil
With cage or with separator	Open type	75 000
	Sealed type	60 000
Full complement	Open type	50 000
	Sealed type	40 000

Note⁽¹⁾ $d_m n$ value = $d_m \times n$
where, d_m : Mean value of bearing bore and outside diameters, mm
 n : Number of rotations per minute, min⁻¹

Rotational torque

Rotational torque of IKO Crossed Roller Bearings are lower than that of plain bearings and the difference between the static torque and the dynamic (kinetic) torque is small. Therefore, these bearings minimize power consumption and operating temperature rise of machinery and increase the overall efficiency of machines.

The rotational torque is affected by many factors, but the following equations can be used expediently.

$$T = \mu P_{or} \frac{D_{pw}}{2}$$

where, T : Rotational torque, N·mm
 μ : Friction coefficient (Approx. 0.010)
 P_{or} : Static equivalent radial load, N
 D_{pw} : Pitch circle diameter, mm

$$\left(D_{pw} \doteq \frac{d + D}{2} \right)$$

Lubrication

These bearings are generally lubricated with grease. Grease is supplied through the clearance between the inner ring and the outer ring.

Grease specification is shown in Table 14, ALVANIA GREASE EP2 (Shell Lubricants Japan K.K.) is prepacked as the lubricating grease.

For bearings without prepacked grease, supply grease or oil for use. Operating without lubrication will increase the wear on the rolling contact surfaces and greatly affect noise and heat generation, leading to a shorter bearing life. For the sealed type, be careful with pressure when applying grease so that the seals do not come off.

When using a special grease, carefully examine the grease properties and contents such as base oil viscosity and extreme pressure additives. In this case, please contact IKO.

Table 14 Bearings with prepacked grease

○ : With prepacked grease × : Without prepacked grease

Model code	Seal specification		
	Open type (No symbol)	Sealed type (UU)	One side sealed type (U)
CRBHV... A	×	○	—
CRBFV... A	×	○	—
CRBC	×	○	×
CRB	×	○	×
CRBT ... A	○	—	—
CRBTF ... A	○	—	—
CRBS	×	—	—
CRBS ... A	—	○	×
CRBS ... V	×	○	×

Oil Hole

For Crossed Roller Bearings, oil holes and oil grooves can be provided on bearing rings if requested. However, this is not applicable to Super Slim Type Crossed Roller Bearings and Mounting Holed Type Super Slim Crossed Roller Bearings. Slim Crossed Roller Bearings. When an oil hole is required on the outer ring, attach "-OH" before the clearance symbol in the identification number. When an oil hole and an oil groove are required on the outer ring, attach "-OG" at the same place in the identification number. For an oil hole on the inner ring, attach "/OH", and for an oil hole and an oil groove on the inner ring, attach "/OG", at the same place in the identification number. High Rigidity Type Crossed Roller Bearings V and Mounting Holed Type High Rigidity Type Crossed Roller Bearings V have an oil groove and two oil holes on the outer ring as standard. Table 15 shows availability of oil holes for each bearing type.

Table 15 Oil holes

Bearing type	Oil hole code			
	/nOH	/nOG	-nOH	-nOG
CRBHV... A	○	○	—	— ⁽¹⁾
CRBFV... A	—	—	—	— ⁽¹⁾
CRBC	○	○	○	○
CRB	○	○	○	○
CRBT ... A	—	—	—	—
CRBTF ... A	—	—	—	—
CRBS	○	—	○	—
CRBS ... A	○	—	○	—
CRBS ... V	○	—	○	—

Notes⁽¹⁾ CRBHV... A and CRBFV... A are provided with an oil groove and two oil holes on the outer ring.
Remark n denotes the number of oil holes not exceeding 4. For one oil hole, number is not indicated.
When preparing multiple oil holes, please contact IKO.

Example 1 When the inner ring has 4 oil holes
CRBC 10020 / 4OH C1

Example 2 When the outer ring has a single oil hole
CRBC 10020 - OH C1

Operating Temperature Range

The operating temperature range for Crossed Roller Bearings is $-20^{\circ}\text{C} \sim +120^{\circ}\text{C}$. However, the maximum allowable temperature for types with separator and with seal is $+110^{\circ}\text{C}$, and $+100^{\circ}\text{C}$ when they are continuously operated.

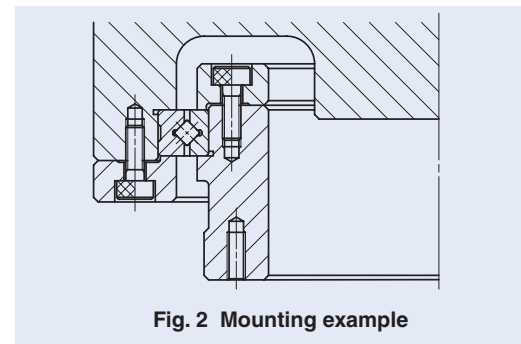
Mounting

When the rigidity of the mounting parts is not sufficient, stress concentration will occur at the contact area between the rollers and raceways, and the bearing performance will be deteriorated significantly.

Therefore, it is necessary to carefully examine the rigidity of housing and the strength of fixing bolts when a large moment will be applied.

The shoulder height diameters (d_a and D_a) that are related to mounting should certainly satisfy the values shown in the dimension tables. When these dimensions are incorrect, deformations of inner and outer rings will occur and the bearing performance will be deteriorated remarkably.

1. Other than Mounting Holed Type Crossed Roller Bearings



① The inner and outer rings should be securely fixed in the axial direction by using fixing plates, etc. Recommended thickness of the fixing plate is 1/2 or more of the bearing width B . The dimensions in the axial direction of the housing bore and the fixing

plates should be determined to get a secure fixing while considering the dimension of bearing width which is given a minus tolerance. (See Fig.2)

② The depth of the housing bore is recommended to be equal to or larger than the bearing width.

③ Separation prevention bolts for the outer ring of Standard Type Crossed Roller Bearings are provided to prevent separation of two halves of the outer ring during transportation or mounting. When mounting, they should be loosened slightly.

④ High Rigidity Type Crossed Roller Bearings V, Super Slim Type Crossed Roller Bearings and Slim Type Crossed Roller Bearings have a plug for hole for inserting rollers. When mounting the bearings, locate the plug at a position that is not included in the maximum loading zone. The plug location can be found by the pin pressed at the side of the outer ring.

2. Mounting Holed Type High Rigidity Crossed Roller Bearings V, Mounting Holed Type Super Slim Crossed Roller Bearings

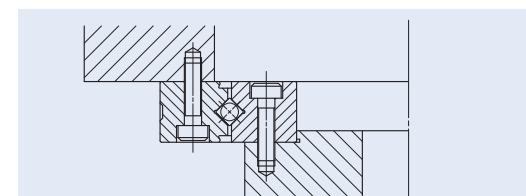


Fig. 3 Example of direct mounting to the mating surface of Mounting Holed Type High Rigidity Crossed Roller Bearings V

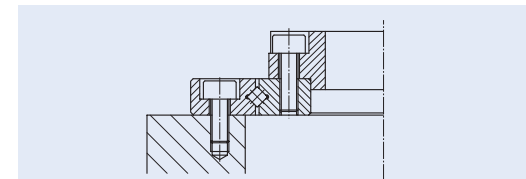


Fig. 4 Example of direct mounting to the mating surface of Mounting Holed Type Super Slim Crossed Roller Bearings

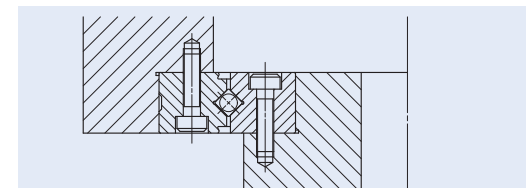


Fig. 5 Example of mounting to the housing of Mounting Holed Type High Rigidity Crossed Roller Bearings V

① Mounting Holed Type High Rigidity Crossed Roller Bearings V, Mounting Holed Type Super Slim Crossed Roller Bearings can be mounted directly to the mounting surface by fixing bolts. (See Fig. 3, Fig. 4)

② Housing is provided when positioning accuracy is required or when a large radial load or moment is loaded. (See Fig. 5)

③ Mounting Holed Type High Rigidity Crossed Roller Bearings V, Mounting Holed Type Super Slim Crossed Roller Bearings have a plug for hole for inserting cylindrical rollers. When mounting the bearings, locate the plug at a position that is not included in the maximum loading zone. The plug location can be found by the pin pressed at the side of the outer ring.

Tightening torque of mounting bolts

The standard tightening torque values for Mounting Holed Type High Rigidity Crossed Roller Bearings V, Mounting Holed Type Super Slim Crossed Roller Bearings mounting bolts are shown in Table 16. When machines or equipment are subjected to severe vibration, shock, large fluctuating load, or moment load, the bolts should be tightened with a torque 1.2 to 1.5 times higher than the standard torque values shown.

If the mating member material is cast iron or aluminum, reduce the tightening torque depending on the strength characteristics of the mating member material.

Please do not tighten with too much torque as abnormal frictional torque or short life may occur.

Table 16 Tightening torque of mounting bolts

Bolt size	Tightening torque N · m
M2.5 × 0.45	0.58
M3 × 0.5	1.7
M4 × 0.7	4.0
M5 × 0.8	7.9
M8 × 1.25	32

Above values are for Carbon steel bolt (Strength division 12.9)

Double Row Angular Contact Roller Bearing

We manufacture Double Row Angular Contact Roller Bearings to order. If needed, please contact IKO.

Double Row Angular Contact Roller Bearings have a large number of cylindrical rollers with a large contact area with a raceway and an excellent load capability, between the inner and outer rings arranged in a double row of raceways. This underpins even higher rigidity and lower torque than High Rigidity Type Crossed Roller Bearings V.

The mounting holes in both inner and outer rings facilitate installation to your machines and equipment. Further, the integrated structure (non split) constructed in both inner and outer rings can avoid installation errors, yielding extra-high-rigidity and high-accuracy guiding performance without being affected by other peripheral structures such as housing or pressure plate.

For lubrication, use the two oil holes on the outer ring outer surface shown in Fig. 6.

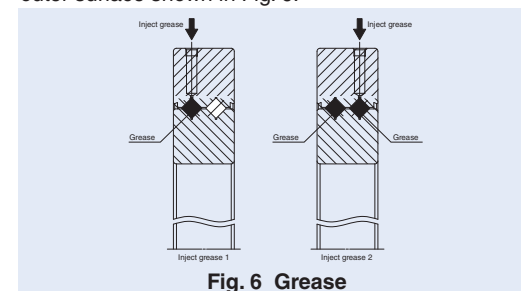


Fig. 6 Grease

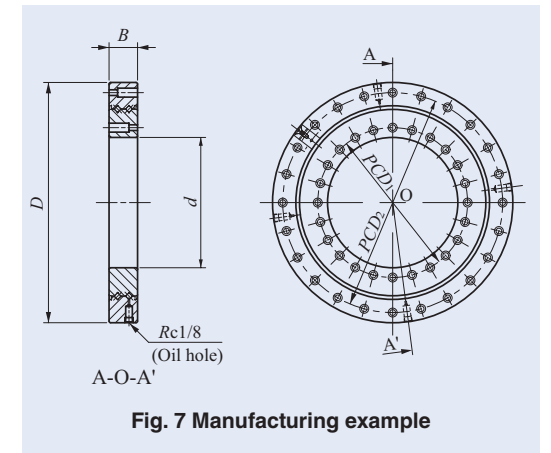
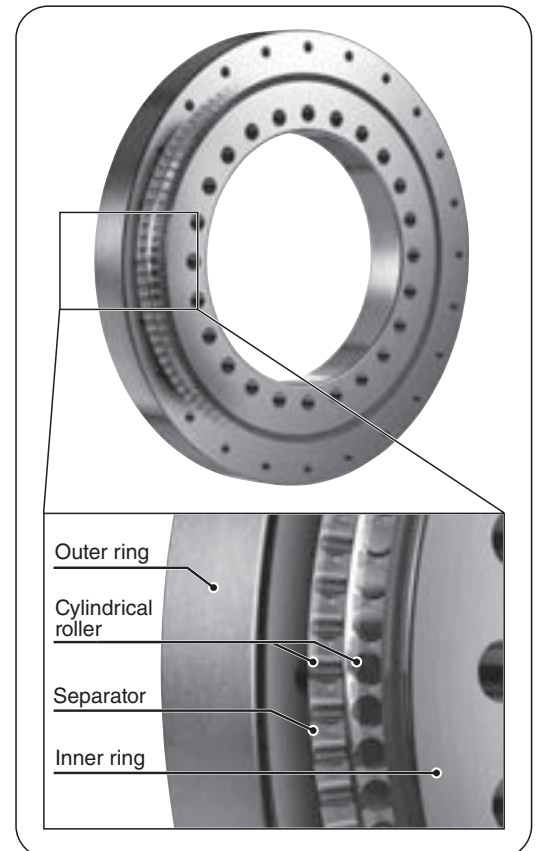


Fig. 7 Manufacturing example

Table 17 Example of manufacturing dimensions

Boundary dimensions mm						Basic dynamic load rating	Basic static load rating
d	D	B	r_{\min}	PCD_1	PCD_2	C N	C_0 N
160	295	35	2	184	270	60 300	167 000
210	380	40	2.5	240	350	108 000	313 000
350	540	50	2.5	385	505	235 000	725 000

Structure of Double-acting Angular Roller Bearing



J

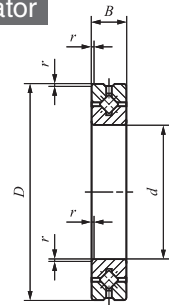
CRBHV
CRBFV
CRB(C)
CRBT
CRBTF
CRBS

CROSSED ROLLER BEARINGS

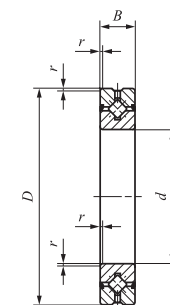
High Rigidity Type Crossed Roller Bearings V

Open Type/With Separator

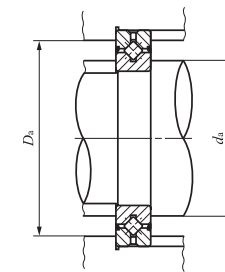
Sealed Type/With Separator



CRBHV ... A



CRBHV ... AUU



Shaft dia. 20 – 300mm

Shaft dia. mm	Identification number High Rigidity Type Crossed Roller Bearings V		Mass (Ref.) kg	Boundary dimensions mm			
	Open Type	Sealed Type		<i>d</i>	<i>D</i>	<i>B</i>	<i>r</i> _{min} ⁽¹⁾
20	CRBHV 208 A	CRBHV 208 A UU	0.04	20	36	8	0.3
25	CRBHV 258 A	CRBHV 258 A UU	0.05	25	41	8	0.3
30	CRBHV 3010 A	CRBHV 3010 A UU	0.12	30	55	10	0.3
35	CRBHV 3510 A	CRBHV 3510 A UU	0.13	35	60	10	0.3
40	CRBHV 4010 A	CRBHV 4010 A UU	0.15	40	65	10	0.3
45	CRBHV 4510 A	CRBHV 4510 A UU	0.16	45	70	10	0.3
50	CRBHV 5013 A	CRBHV 5013 A UU	0.29	50	80	13	0.6
60	CRBHV 6013 A	CRBHV 6013 A UU	0.33	60	90	13	0.6
70	CRBHV 7013 A	CRBHV 7013 A UU	0.38	70	100	13	0.6
80	CRBHV 8016 A	CRBHV 8016 A UU	0.74	80	120	16	0.6
90	CRBHV 9016 A	CRBHV 9016 A UU	0.81	90	130	16	0.6
100	CRBHV 10020 A	CRBHV 10020 A UU	1.45	100	150	20	0.6
110	CRBHV 11020 A	CRBHV 11020 A UU	1.56	110	160	20	0.6
120	CRBHV 12025 A	CRBHV 12025 A UU	2.62	120	180	25	1
130	CRBHV 13025 A	CRBHV 13025 A UU	2.82	130	190	25	1
140	CRBHV 14025 A	CRBHV 14025 A UU	2.96	140	200	25	1
150	CRBHV 15025 A	CRBHV 15025 A UU	3.16	150	210	25	1
200	CRBHV 20025 A	CRBHV 20025 A UU	4.00	200	260	25	1
250	CRBHV 25025 A	CRBHV 25025 A UU	4.97	250	310	25	1.5
300	CRBH 30025 A	CRBH 30025 A UU	5.29	300	360	25	1.5

Note⁽¹⁾ Minimum allowable single value of chamfer dimension *r*

Remarks1. The outer ring has an oil groove and two oil holes.

2. No grease is prepacked for Open Type. Perform proper lubrication. Grease is prepacked for Sealed Type.

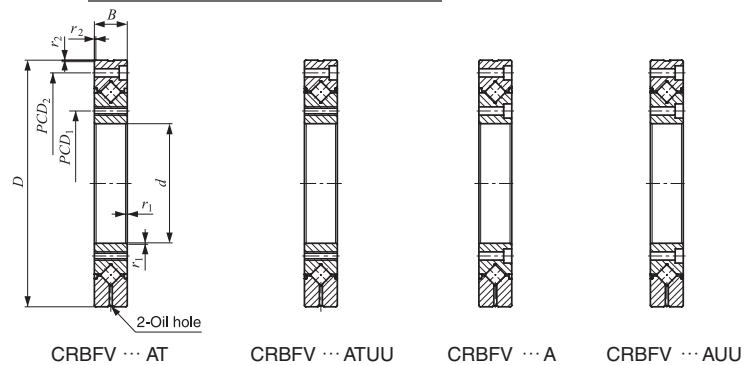
3. If one side sealed type are needed, please contact IKO.

Mounting dimensions mm		Basic dynamic load rating <i>C</i> N	Basic static load rating <i>C</i> ₀ N
<i>d</i> _a	<i>D</i> _a		
24	31	2 910	2 430
29	36	3 120	2 810
36.5	48.5	7 600	8 370
41.5	53.5	7 900	9 130
46.5	58.5	8 610	10 600
51.5	63.5	8 860	11 300
56	74	17 300	20 900
66	84	18 800	24 300
76	94	20 100	27 700
88	112	32 100	43 400
98	122	33 100	46 800
110	140	50 900	72 200
120	150	52 400	77 400
132	168	73 400	108 000
142	178	75 900	115 000
152	188	81 900	130 000
162	198	84 300	138 000
212	248	92 300	169 000
262	298	102 000	207 000
312	348	112 000	245 000

J
CRBHV
CRBFV
CRB(C)
CRBT
CRBTF
CRBS

CROSSED ROLLER BEARINGS

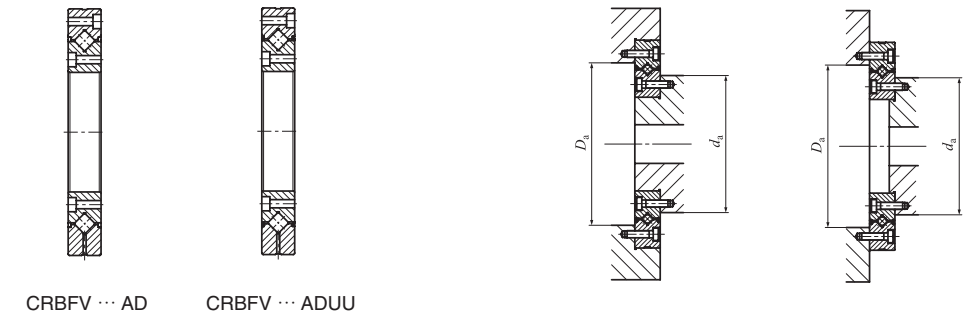
Mounting Holed Type High Rigidity **Open Type/With Separator**
 Crossed Roller Bearings V **Sealed Type/With Separator**



Shaft dia. 10 – 115mm

Shaft dia. mm	Identification number		Mass (Ref.) kg	Boundary dimensions mm				
	Open Type	Sealed Type		<i>d</i>	<i>D</i>	<i>B</i>	⁽¹⁾ <i>r</i> _{1min}	⁽¹⁾ <i>r</i> _{2min}
10	CRBFV 108 AT	CRBFV 108 AT UU	0.12	10	52	8	0.3	0.3
20	CRBFV 2012 AT	CRBFV 2012 AT UU	0.31	20	70	12	0.3	0.3
25	CRBFV 2512 AT	CRBFV 2512 AT UU	0.40	25	80	12	0.6	0.6
35	CRBFV 3515 AT	CRBFV 3515 AT UU	0.66	35	95	15	0.6	0.6
55	CRBFV 5515 AT	CRBFV 5515 AT UU	0.96	55	120	15	0.6	0.6
80	CRBFV 8022 AT	CRBFV 8022 AT UU	2.63	80	165	22	0.6	1
	CRBFV 8022 A	CRBFV 8022 A UU	2.60					
	CRBFV 8022 AD	CRBFV 8022 AD UU						
90	CRBFV 9025 AT	CRBFV 9025 AT UU	4.83	90	210	25	1.5	1.5
	CRBFV 9025 A	CRBFV 9025 A UU	4.67					
	CRBFV 9025 AD	CRBFV 9025 AD UU						
115	CRBFV 11528 AT	CRBFV 11528 AT UU	6.81	115	240	28	1.5	1.5
	CRBFV 11528 A	CRBFV 11528 A UU	6.63					
	CRBFV 11528 AD	CRBFV 11528 AD UU						

Note⁽¹⁾ Minimum allowable single value of chamfer diameter *r*₁ and *r*₂.
 Remarks1. The outer ring has an oil groove and two oil holes.
 2. No grease is prepacked for Open Type. Perform proper lubrication. Grease is prepacked for Sealed Type.
 3. If one side sealed type are needed, please contact IKO.



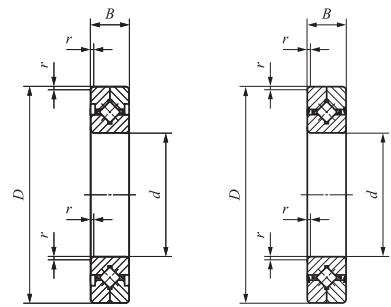
<i>PCD</i> ₁	Mounting holes mm		<i>PCD</i> ₂	Mounting dimensions mm		Basic dynamic load rating <i>C</i> N	Basic static load rating <i>C</i> ₀ N
	Inner ring Mounting holes	Outer ring Mounting holes		<i>d</i> _a	<i>D</i> _a		
16	4-M3 through	6-φ3.4 through φ6.5 counter bore depth 3.3	42	24	31	2 910	2 430
28	6-M3 through	6-φ3.4 through φ6.5 counter bore depth 3.3	57	36.5	48.5	7 600	8 370
35	6-M3 through	6-φ3.4 through φ6.5 counter bore depth 3.3	67	46.5	58.5	8 610	10 600
45	8-M4 through	8-φ4.5 through φ8 counter bore depth 4.4	83	56	74	17 300	20 900
65	8-M5 through	8-φ5.5 through φ9.5 counter bore depth 5.4	105	76	94	20 100	27 700
97	10-M5 through	10-φ5.5 through φ9.5 counter bore depth 5.4	148	107	137	51 100	72 000
	10-φ5.5 through φ9.5 counter bore depth 5.4						
112	12-M8 through	12-φ9 through φ14 counter bore depth 12	187	132	168	73 400	108 000
	12-φ9 through φ14 counter bore depth 12						
139	12-M8 through	12-φ9 through φ14 counter bore depth 13.5	217	162	198	84 300	138 000
	12-φ9 through φ14 counter bore depth 13.5						

J
 CRBHV
 CRBFV
 CRB(C)
 CRBT
 CRBTF
 CRBS

CROSSED ROLLER BEARINGS

Standard Type Crossed Roller Bearings

- Open Type/With Cage Open Type/Full Complement Type
- Sealed Type/With Cage Sealed Type/Full Complement Type



CRBC

CRBC...UU

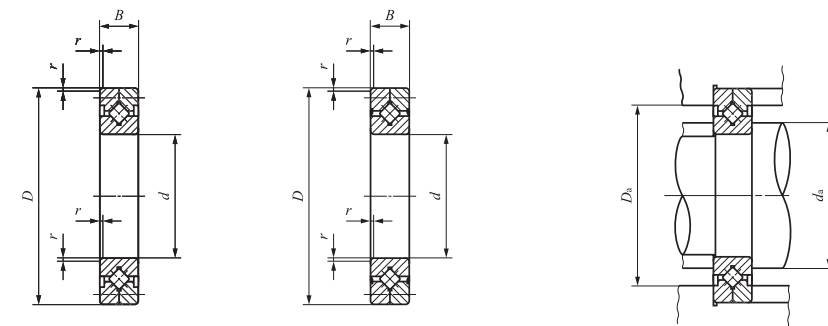
Shaft dia. 30 – 200mm

Shaft dia. mm	Identification number				Mass (Ref.) kg	Boundary dimensions mm		
	With Cage		Full complement			d	D	B
	Open Type	Sealed Type	Open Type	Sealed Type				
30	CRBC 3010	CRBC 3010 UU	CRB 3010	CRB 3010 UU	0.12	30	55	10
40	CRBC 4010	CRBC 4010 UU	CRB 4010	CRB 4010 UU	0.15	40	65	10
50	CRBC 5013	CRBC 5013 UU	CRB 5013	CRB 5013 UU	0.29	50	80	13
60	CRBC 6013	CRBC 6013 UU	CRB 6013	CRB 6013 UU	0.33	60	90	13
70	CRBC 7013	CRBC 7013 UU	CRB 7013	CRB 7013 UU	0.38	70	100	13
80	CRBC 8016	CRBC 8016 UU	CRB 8016	CRB 8016 UU	0.74	80	120	16
90	CRBC 9016	CRBC 9016 UU	CRB 9016	CRB 9016 UU	0.81	90	130	16
100	CRBC 10020	CRBC 10020 UU	CRB 10020	CRB 10020 UU	1.45	100	150	20
110	CRBC 11020	CRBC 11020 UU	CRB 11020	CRB 11020 UU	1.56	110	160	20
120	CRBC 12025	CRBC 12025 UU	CRB 12025	CRB 12025 UU	2.62	120	180	25
130	CRBC 13025	CRBC 13025 UU	CRB 13025	CRB 13025 UU	2.82	130	190	25
140	CRBC 14025	CRBC 14025 UU	CRB 14025	CRB 14025 UU	2.96	140	200	25
150	CRBC 15025	CRBC 15025 UU	CRB 15025	CRB 15025 UU	3.16	150	210	25
	CRBC 15030	CRBC 15030 UU	CRB 15030	CRB 15030 UU	5.30	150	230	30
200	CRBC 20025	CRBC 20025 UU	CRB 20025	CRB 20025 UU	4.00	200	260	25
	CRBC 20030	—	CRB 20030	—	6.70	200	280	30
	CRBC 20035	—	CRB 20035	—	9.58	200	295	35

Note(1) Minimum allowable single value of chamfer dimension r

Remarks1. No oil hole is provided.

2. No grease is prepacked for Open Type. Perform proper lubrication. Grease is prepacked for Sealed Type.



CRB

CRB...UU

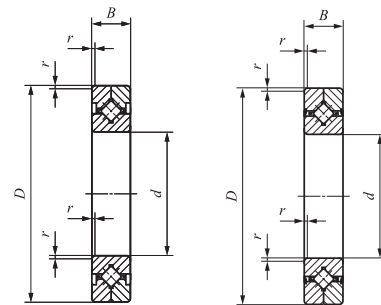
r _{min} ⁽¹⁾	Mounting dimensions mm		CRBC		CRB	
	d _a	D _a	Basic dynamic load rating C N	Basic static load rating C ₀ N	Basic dynamic load rating C N	Basic static load rating C ₀ N
	0.3	34	44	3 830	4 130	5 290
0.3	44	54	4 280	5 140	5 980	8 040
0.6	55	71	10 700	12 600	14 200	18 400
0.6	64	81	11 600	14 600	15 400	21 500
0.6	75	91	12 300	16 700	17 000	25 500
0.6	86	107	18 200	25 500	24 300	37 500
1	98	118	19 400	28 600	25 900	42 100
1	108	134	31 500	45 100	39 400	61 100
1	118	144	33 500	50 700	41 200	66 700
1.5	132	164	47 700	70 500	59 900	95 400
1.5	140	172	49 200	74 800	61 000	99 800
1.5	151	183	50 700	79 200	64 100	108 000
1.5	160	192	53 800	87 700	65 000	113 000
1.5	166	202	69 200	108 000	85 900	144 000
2	208	239	60 200	110 000	75 300	148 000
2	218	262	108 000	178 000	133 000	234 000
2	221	274	137 000	215 000	168 000	282 000

J
CRBHV
CRBFV
CRB(C)
CRBT
CRBTf
CRBS

CROSSED ROLLER BEARINGS

Standard Type Crossed Roller Bearings

- Open Type/With Cage Open Type/Full Complement Type
- Sealed Type/With Cage Sealed Type/Full Complement Type



CRBC 25025
CRBC 30025 CRB 25025UU
CRB 30025UU

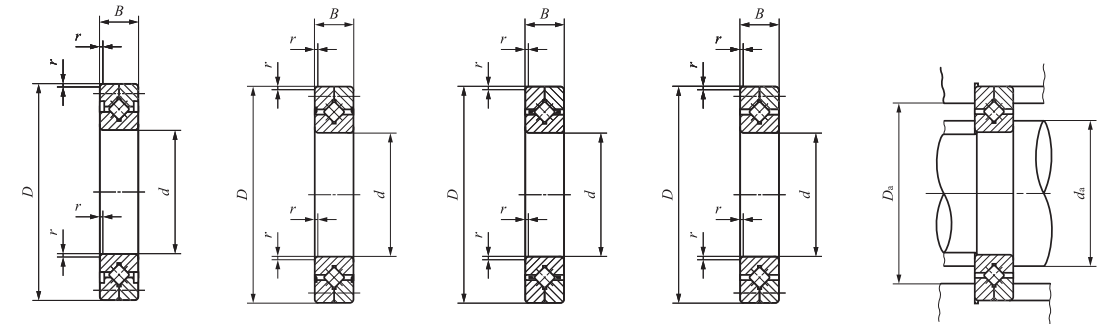
Shaft dia. 250 – 800mm

Shaft dia. mm	Identification number				Mass (Ref.) kg	Boundary dimensions mm		
	With Cage		Full complement			d	D	B
	Open Type	Sealed Type	Open Type	Sealed Type				
250	CRBC 25025	CRBC 25025 UU	CRB 25025	CRB 25025 UU	4.97	250	310	25
	CRBC 25030	—	CRB 25030	—	8.10	250	330	30
	CRBC 25040	—	CRB 25040	—	14.8	250	355	40
300	CRBC 30025	CRBC 30025 UU	CRB 30025	CRB 30025 UU	5.88	300	360	25
	CRBC 30035	—	CRB 30035	—	13.4	300	395	35
	CRBC 30040	—	CRB 30040	—	17.2	300	405	40
400	CRBC 40035	—	CRB 40035	—	14.5	400	480	35
	CRBC 40040	—	CRB 40040	—	23.5	400	510	40
	CRBC 40070	—	CRB 40070	—	72.4	400	580	70
500	CRBC 50040	—	CRB 50040	—	26.0	500	600	40
	CRBC 50050	—	CRB 50050	—	41.7	500	625	50
	CRBC 50070	—	CRB 50070	—	86.1	500	680	70
600	CRBC 60040	—	CRB 60040	—	30.6	600	700	40
	CRBC 60070	—	CRB 60070	—	102	600	780	70
	CRBC 600120	—	CRB 600120	—	274	600	870	120
700	CRBC 70045	—	CRB 70045	—	46.5	700	815	45
	CRBC 70070	—	CRB 70070	—	115	700	880	70
	CRBC 700150	—	CRB 700150	—	478	700	1 020	150
800	CRBC 80070	—	CRB 80070	—	109	800	950	70
	CRBC 800100	—	CRB 800100	—	247	800	1 030	100

Note(1) Minimum allowable single value of chamfer dimension r

Remarks1. No oil hole is provided.

2. No grease is prepacked for Open Type. Perform proper lubrication. Grease is prepacked for Sealed Type.



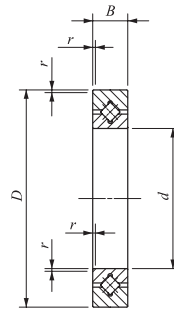
CRB 25025
CRB 30025 CRB 25025UU
CRB 30025UU CRBC CRB

r _{min} ⁽¹⁾	Mounting dimensions mm		CRBC		CRB	
	d _a	D _a	Basic dynamic load rating C N	Basic static load rating C ₀ N	Basic dynamic load rating C N	Basic static load rating C ₀ N
	2.5	259	290	67 200	136 000	83 900
2.5	265	310	116 000	208 000	146 000	283 000
2.5	271	330	179 000	299 000	215 000	382 000
2.5	310	341	73 800	162 000	91 900	217 000
2.5	318	372	163 000	299 000	205 000	408 000
2.5	321	381	194 000	351 000	235 000	451 000
2.5	414	457	133 000	300 000	165 000	400 000
2.5	423	483	222 000	455 000	270 000	590 000
2.5	430	532	470 000	811 000	576 000	1 060 000
2.5	517	573	212 000	497 000	259 000	648 000
2.5	531	592	247 000	561 000	306 000	747 000
2.5	530	633	536 000	1 020 000	653 000	1 330 000
3	621	676	231 000	581 000	287 000	774 000
3	630	734	591 000	1 230 000	700 000	1 540 000
3	643	817	1 250 000	2 210 000	1 490 000	2 800 000
3	730	785	250 000	681 000	313 000	917 000
3	731	834	630 000	1 390 000	766 000	1 810 000
3	751	953	1 660 000	3 010 000	1 980 000	3 820 000
4	831	907	417 000	1 090 000	513 000	1 440 000
4	840	972	936 000	2 040 000	1 140 000	2 640 000

J
CRBHV
CRBFV
CRB(C)
CRBT
CRBTF
CRBS

CROSSED ROLLER BEARINGS

Super Slim Type Crossed Roller Bearings **Open Type/With Separator**

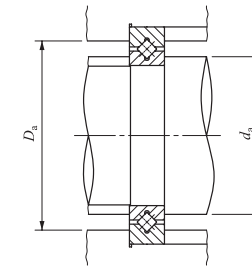


CRBT ... A

Shaft dia. 10 – 50mm

Shaft dia. mm	Identification number	Mass (Ref.) g	Boundary dimensions mm				Mounting dimensions mm		Basic dynamic load rating C N
			d	D	B	r ⁽¹⁾ r _{min}	d _a	D _a	
10	CRBT 105 A	9.0	10	21	5	0.15	12.5	17	1 120
15	CRBT 155 A	11.9	15	26	5	0.15	17.5	22	1 320
20	CRBT 205 A	14.8	20	31	5	0.15	22.5	27	1 400
30	CRBT 305 A	20.7	30	41	5	0.15	32.5	37	1 770
40	CRBT 405 A	26.5	40	51	5	0.15	42.5	47	2 000
50	CRBT 505 A	32.3	50	61	5	0.15	52.5	57	2 280

Note⁽¹⁾ Minimum allowable single value of chamfer dimension *r*.
 Remarks1. No oil hole is provided.
 2. Grease is prepacked.

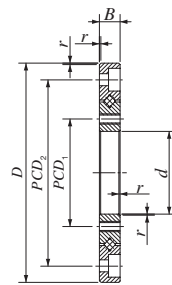


Basic static load rating C ₀ N
811
1 110
1 290
1 970
2 520
3 200

J
 CRBHV
 CRBFV
 CRB(C)
 CRBT
 CRBTF
 CRBS

CROSSED ROLLER BEARINGS

Mounting Holed Type Super Slim Crossed Roller Bearings **Open type/With Separator**

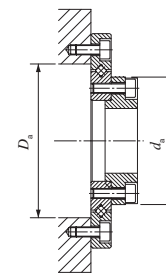


CRBTF...A

Shaft dia 10 – 40mm

Shaft dia. mm	Identification number	Mass (Ref.) g	Boundary dimensions mm				⁽¹⁾ r_{min}	PCD_1	Inner ring Mounting holes
			d	D	B				
10	CRBTF 105 AT	46	10	43	5	0.15	16	6-M2.5 through	
20	CRBTF 205 AT	66	20	53	5	0.15	26	6-M2.5 through	
30	CRBTF 305 AT	83	30	63	5	0.15	36	8-M2.5 through	
40	CRBTF 405 AT	103	40	73	5	0.15	46	8-M2.5 through	

Note⁽¹⁾ Minimum allowable single value of chamfer dimension r .
 Remarks1. No oil hole is provided.
 2. Grease is prepacked.



PCD_a	Mounting holes mm		Mounting dimensions mm		Basic dynamic load rating C N	Basic static load rating C_0 N
	Outer ring Mounting holes		d_a	D_a		
35	6- ϕ 2.9 through ϕ 5.5 counter bore depth 2.8		21.5	28	1 500	1 410
45	6- ϕ 2.9 through ϕ 5.5 counter bore depth 2.8		31.5	38	1 890	2 150
55	8- ϕ 2.9 through ϕ 5.5 counter bore depth 2.8		41.5	47.5	2 140	2 750
65	8- ϕ 2.9 through ϕ 5.5 counter bore depth 2.8		51.5	58	2 440	3 490

J

CRBHV
CRBFV
CRB(C)
CRBT
CRBTF
CRBS

CROSSED ROLLER BEARINGS

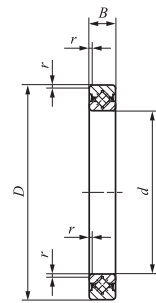
Slim Type Crossed Roller Bearings

Open Type/With Cage

Open Type/Full Complement Type

Sealed Type/With Separator

Sealed Type/Full Complement Type

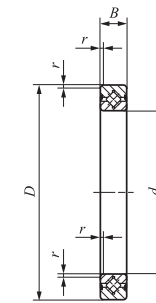


CRBS

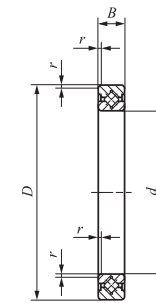
Shaft dia. 50 – 200mm

Shaft dia. mm	Identification number					Mass (Ref.) g
	With Cage Open Type	With Separator Sealed Type	Full complement			
			Open Type	Sealed Type		
50	CRBS 508	CRBS 508 A UU	CRBS 508 V	CRBS 508 V UU	84	
60	CRBS 608	CRBS 608 A UU	CRBS 608 V	CRBS 608 V UU	94	
70	CRBS 708	CRBS 708 A UU	CRBS 708 V	CRBS 708 V UU	108	
80	CRBS 808	CRBS 808 A UU	CRBS 808 V	CRBS 808 V UU	122	
90	CRBS 908	CRBS 908 A UU	CRBS 908 V	CRBS 908 V UU	135	
100	CRBS 1008	CRBS 1008 A UU	CRBS 1008 V	CRBS 1008 V UU	152	
110	CRBS 1108	CRBS 1108 A UU	CRBS 1108 V	CRBS 1108 V UU	163	
120	CRBS 1208	CRBS 1208 A UU	CRBS 1208 V	CRBS 1208 V UU	184	
130	CRBS 1308	CRBS 1308 A UU	CRBS 1308 V	CRBS 1308 V UU	199	
140	CRBS 1408	CRBS 1408 A UU	CRBS 1408 V	CRBS 1408 V UU	205	
150	CRBS 1508	CRBS 1508 A UU	CRBS 1508 V	CRBS 1508 V UU	220	
160	CRBS 16013	CRBS 16013 A UU	CRBS 16013 V	CRBS 16013 V UU	620	
170	CRBS 17013	CRBS 17013 A UU	CRBS 17013 V	CRBS 17013 V UU	675	
180	CRBS 18013	CRBS 18013 A UU	CRBS 18013 V	CRBS 18013 V UU	710	
190	CRBS 19013	CRBS 19013 A UU	CRBS 19013 V	CRBS 19013 V UU	740	
200	CRBS 20013	CRBS 20013 A UU	CRBS 20013 V	CRBS 20013 V UU	780	

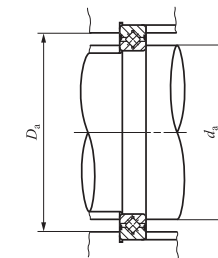
Note⁽¹⁾ Minimum allowable single value of chamfer dimension *r*
⁽²⁾ No grease is prepacked. Perform proper lubrication.
⁽³⁾ Grease is prepacked.
 Remark No oil hole is provided.



CRBS...AUU
...VUU



CRBS...V



Boundary dimensions mm				Mounting dimensions mm		CRBS ⁽²⁾ With cage		CRBS...AUU ⁽³⁾ With Separator		CRBS...V ⁽²⁾ CRBS...VUU ⁽³⁾ Full complement	
<i>d</i>	<i>D</i>	<i>B</i>	<i>r</i> _{min} ⁽¹⁾	<i>d</i> _a	<i>D</i> _a	Basic dynamic load rating <i>C</i> _N	Basic static load rating <i>C</i> ₀ _N	Basic dynamic load rating <i>C</i> _N	Basic static load rating <i>C</i> ₀ _N	Basic dynamic load rating <i>C</i> _N	Basic static load rating <i>C</i> ₀ _N
50	66	8	0.4	54	61	4 900	6 170	4 680	5 810	6 930	9 800
60	76	8	0.4	64	71	5 350	7 310	5 350	7 310	7 600	11 700
70	86	8	0.4	74	81	5 740	8 440	5 740	8 440	8 190	13 600
80	96	8	0.4	84	91	6 130	9 590	6 130	9 590	8 790	15 500
90	106	8	0.4	94	101	6 490	10 700	6 490	10 700	9 310	17 400
100	116	8	0.4	104	111	6 850	11 900	6 530	11 100	9 850	19 300
110	126	8	0.4	114	121	7 160	13 000	6 850	12 300	10 300	21 200
120	136	8	0.4	124	131	7 530	14 100	7 070	13 000	10 900	23 000
130	146	8	0.4	134	141	7 860	15 300	7 270	13 800	11 200	24 600
140	156	8	0.4	144	151	8 060	16 400	7 510	14 900	11 700	26 800
150	166	8	0.4	154	161	8 350	17 500	7 810	16 000	12 100	28 700
160	186	13	0.6	166	179	20 300	39 900	19 400	37 700	26 900	58 200
170	196	13	0.6	176	189	20 900	42 200	20 000	39 900	27 800	61 600
180	206	13	0.6	186	199	21 500	44 600	21 900	45 700	28 600	65 200
190	216	13	0.6	196	209	22 100	46 900	22 900	49 200	29 300	68 600
200	226	13	0.6	206	219	22 500	49 300	23 300	51 600	30 000	72 200

J
 CRBHV
 CRBFV
 CRB(C)
 CRBT
 CRBTF
 CRBS

SPHERICAL BUSHINGS

- Steel-on-steel Spherical Bushings
- Maintenance-free Spherical Bushings



Structure and Features

IKO Spherical Bushings are self-aligning spherical plain bushings that have inner and outer rings with spherical sliding surfaces, and can take a large radial load and a bi-directional axial load at the same time. There are many types of Spherical Bushings, but they are basically divided into steel-on-steel types and maintenance-free types according to the kind of sliding surfaces.

Steel-on-steel Spherical Bushings have inner and outer rings of high carbon chromium bearing steel, of which sliding surfaces are phosphate-treated and then dry-coated with molybdenum disulfide (MoS₂). They can, therefore, operate with low torque, and have excellent wear resistance and large load capacity. They are especially suitable for applications where there are alternate loads and shock loads. They have wide applications mainly in industrial and construction machinery.

Maintenance-free Spherical Bushings consist of an outer ring which has a special PTFE liner reinforced with copper alloy meshes on the sliding surface, and a spherical inner ring of which sliding surface has a hard chromium plating. Creep deformation due to compressive load is small, and wear resistance is superior. Thus, they are maintenance-free and can be used for extended periods of time without re-lubrication. They are especially suitable in cases where fixed directional loads are applied and are used mainly in food processing machines and construction machinery and in other applications in which the use of oil is undesirable or lubrication is not possible.

Types

Spherical Bushings are available in various types shown in Table 1.

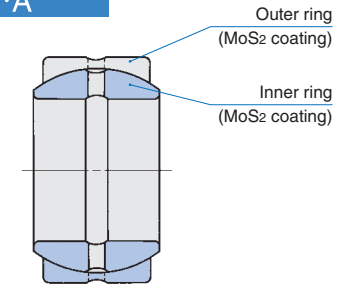
Table 1 Type of bearing

Series	Type	Steel-on-steel		Maintenance-free	
		Without seals	With seals	Without seals	With seals
Metric	SB		—	GE ... EC	GE ... EC-2RS
	SB ... A		—		
	GE ... E, ES	GE ... ES-2RS			
	GE ... G, GS	GE ... GS-2RS			
Inch	SBB	SBB ... -2RS	—	—	

Structures of Spherical Bushings

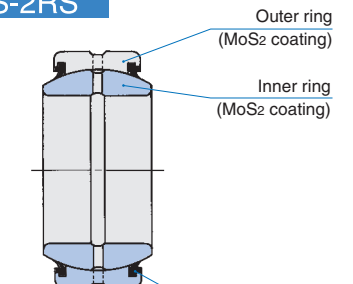
Steel-on-steel type

SB ... A



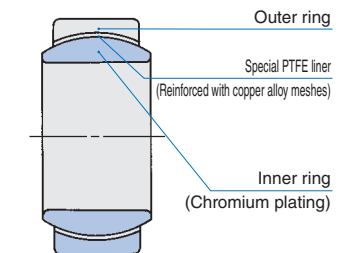
Steel-on-steel type

GE ... ES-2RS



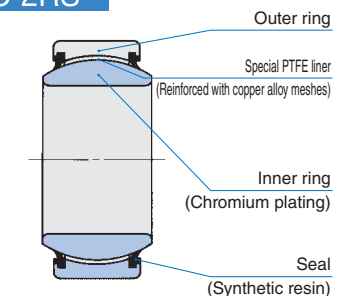
Maintenance-free type

GE ... EC



Maintenance-free type

GE ... EC-2RS



K

SB
GE
SBB

Steel-on-steel Spherical Bushings SB

These bushings have an outer ring split into halves. The split outer ring and the inner ring are held together by a snap ring placed in the groove around the outer periphery of the outer ring.

Steel-on-steel Spherical Bushings SB...A

These bushings have an outer ring split only at one position, and therefore, the outer and inner rings will not separate. Handling before mounting and mounting to the housing are simple. The boundary dimensions are the same as those of the SB type. Therefore, SB and SB...A types are dimensionally interchangeable, but the radial internal clearances of the SB...A type are smaller than those of the SB type.

Steel-on-steel Spherical Bushings GE...E, GE...ES

The dimension series of these types conform to ISO standards and they can be used internationally. The outer ring is split at one position. The GE...E and GE...ES types are available. These are classified by bushing size.

The GE...ES type can be provided with seals, which are double-lip type polyurethane seals effective for prevention against grease leakage and dust penetration. The sealed type is indicated by the suffix "-2RS" at the end of the identification number.

Steel-on-steel Spherical Bushings GE...G, GE...GS

As compared with the GE...E and GE...ES types, these bushings have larger load capacities and larger permissible tilting angles. The dimension series also conform to ISO standards, and they can be used internationally. The outer ring is split at one position. The GE...G and GE...GS types are available. They are classified by bushing size.

The GE...GS type can be provided with seals, which are double-lip type polyurethane seals effective for prevention against grease leakage and dust penetration. The sealed type is indicated by the suffix "-2RS" at the end of the identification number.

Steel-on-steel Spherical Bushings SBB

These are inch series bushings. The outer ring is split at one position.

These bushings can be provided with seals, which are double-lip type polyurethane seals effective for prevention against grease leakage and dust penetration. The sealed type is indicated by the suffix "-2RS" at the end of the identification number.

Maintenance-free Spherical Bushings GE...EC

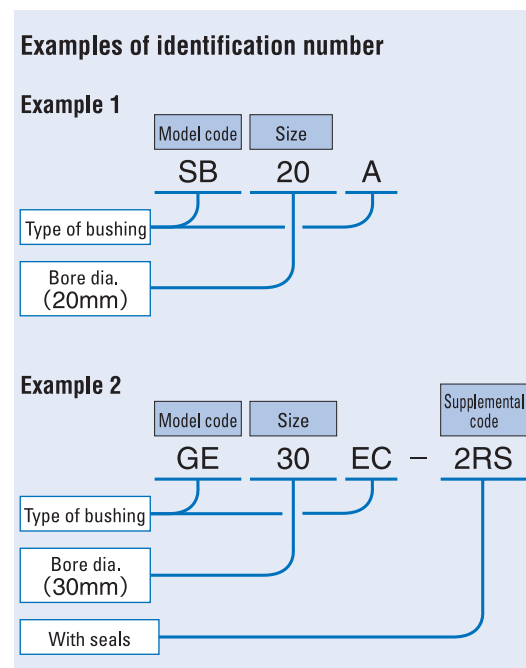
These bushings have the same boundary dimensions as the GE...ES type and can be used internationally. A special PTFE liner reinforced with copper alloy meshes is used on the sliding surface. Therefore, creep deformation due to compressive loads is small, and wear resistance is superior. These bushings are used as maintenance-free bushings.

These bushings can be provided with synthetic resin seals which are effective in preventing dust penetration. They are indicated by the suffix "-2RS" at the end of the identification number.

Spherical Bushings with superior rust prevention properties, which can be used in a corrosive environment or in an environment where water splashes, are also available on request. Please consult IKO.

Identification number

The identification number of Spherical Bushings consists of a model code, a size and any supplemental codes. Examples are shown below.



Accuracy

The tolerances of Steel-on-steel Spherical Bushings of the metric series is shown in Table 2.

The tolerances of the GE type are applicable to bushings before splitting the outer ring and after surface treatment.

The tolerances of the SB and SB...A types are applicable to bushings before splitting the outer ring and before surface treatment.

The tolerances of the GE...EC type are applicable to bushings before splitting the outer ring.

The tolerances of the Spherical Bushings of the inch series are shown in Table 3. The tolerances of the bore diameter are applicable to bushings after surface treatment, while other tolerances are applicable to bushings before splitting the outer ring and before surface treatment.

Although minor dimensional changes may occur during surface treatment, they have negligible influence on the overall performance.

Table 2 Tolerances of inner and outer rings of metric series (JIS Class 0) unit: μm

d or D ⁽¹⁾ Nominal bore dia. or outside dia. mm	Δ_{dmp} Single plane mean bore dia. deviation		Δ_{Dmp} Single plane mean outside dia. deviation		Δ_{Bs} or Δ_{Cs} Deviation of a single inner ring width or outer ring width	
	High	Low	High	Low	High	Low
2.5	6	0 - 8	-	-	0	-120
6	18	0 - 8	0	- 8	0	-120
18	30	0 - 10	0	- 9	0	-120
30	50	0 - 12	0	- 11	0	-120
50	80	0 - 15	0	- 13	0	-150
80	120	0 - 20	0	- 15	0	-200
120	150	0 - 25	0	- 18	0	-250
150	180	0 - 25	0	- 25	0	-250
180	250	0 - 30	0	- 30	0	-300
250	315	0 - 35	0	- 35	0	-350
315	400	0 - 40	0	- 40	0	-400
400	500	0 - 45	0	- 45	0	-450

Note⁽¹⁾ d for Δ_{dmp} , Δ_{Bs} and Δ_{Cs} and D for Δ_{Dmp} , respectively.

Table 3 Tolerances of inner and outer rings of inch series SBB unit: μm

d or D ⁽¹⁾ Nominal bore dia. or outside dia. mm	Δ_{dmp} Single plane mean bore dia. deviation		Δ_{Dmp} Single plane mean outside dia. deviation		Δ_{Bs} or Δ_{Cs} Deviation of a single inner ring width or outer ring width	
	High	Low	High	Low	High	Low
-	50.800	0 - 13	0	- 13	0	- 130
50.800	76.200	0 - 15	0	- 15	0	- 130
76.200	80.962	0 - 20	0	- 15	0	- 130
80.962	120.650	0 - 20	0	- 20	0	- 130
120.650	152.400	0 - 25	0	- 25	0	- 130
152.400	177.800	-	-	0 - 25	0	- 130
177.800	222.250	-	-	0 - 30	0	- 130

Note⁽¹⁾ d for Δ_{dmp} , Δ_{Bs} and Δ_{Cs} and D for Δ_{Dmp} , respectively.

Clearance

The radial internal clearances of Spherical Bushings are the values before splitting the outer ring, and are shown in Tables 4, 5 and 6. The radial internal clearances of the inch series are shown in the dimension table.

Clearances other than these can also be prepared on request. Please consult IKO.

Table 4 Radial internal clearance of SB and SB...A types (Steel-on-steel) unit: μm

Nominal bore dia. d mm	SB type		SB...A type	
	Min.	Max.	Min.	Max.
12			32	68
15	70	125	40	82
20				
22				
25	75	140	50	100
30				
35				
40	85	150	60	120
45				
50				
55				
60	90	160		
65				
70			72	142
75	95	170		
80				
85				
90	100	185	85	165
95				
100				
110				
115	110	200		
120				
130				
150	120	215	100	192

Table 5 Radial internal clearance of GE type (Steel-on-steel)
unit: μm

Nominal bore dia. mm		Radial internal clearance	
GE...E GE...ES	GE...G GE...GS	Min.	Max.
4	—	32	68
5	—		
6	—		
8	6		
10	8		
12	10		
15	12	40	82
17	15		
20	17		
25	20	50	100
30	25		
35	30		
40	35		
45	40		
50	45	60	120
60	50		
70	60		
80	70		
90	80	72	142
100	90		
110	100	85	165
120	110		
140	120		
160	140		
180	160	100	192
200	180		
220	200		
240	220		
260	240		
280	260	110	214
300	280		

Remark Also applicable to bushings with seals.

Table 6 Radial internal clearance of GE...EC type (Maintenance-free)
unit: μm

Nominal bore dia. mm	Radial internal clearance	
	Min.	Max.
15	0	40
17		
20		
25	0	50
30		
35		
40		
45	0	60
50		
60		
70		
70	0	72

Remark Also applicable to bushings with seals.

Fit

The recommended fits for Spherical Bushings are shown in Tables 7 and 8.

Table 7 Recommended fits for Steel-on-steel Spherical Bushings

Condition	Tolerance class	
	Shaft	Housing bore
Normal operation	h6, j6	H7, J7
With directionally indeterminate load	m6, n6	M7, N7

Remark N7 tolerance is recommended for light metal housings.

Table 8 Recommended fits for Maintenance-free Spherical Bushings

Tolerance class of shaft	Tolerance class of housing bore
h6, j6	H7, J7, K7

Remark K7 tolerance is recommended for light metal housings.

Selection of Spherical Bushings

Selection between the steel-on-steel type and the maintenance-free type is made considering the operating conditions such as load, lubrication, temperature, and sliding velocity.

Load capacity

1 Dynamic load capacity

The dynamic load capacity C_d is the maximum allowable load that can be applied on a spherical bushing under oscillating motion. It is obtained on the basis of the contact pressure on the spherical surfaces. The dynamic load capacity is also used for calculating the life of spherical bushings.

The recommended value of bushing load is obtained by multiplying the dynamic load capacity C_d by a numerical factor, which differs depending on the bushing type and the load condition. A guideline for selection is shown in Table 9.

Table 9 Guide for determination of load

Type of bushing	Load direction	
	Constant	Alternate
Steel-on-steel	$\leq 0.3C_d$	$\leq 0.6C_d$
Maintenance-free	$\leq C_d$	$\leq 0.5C_d$

When the magnitude of load exceeds the value given in Table 9, please consult IKO.

The dynamic load capacity C_{dt} considering the influence of bushing temperature can be obtained from the following equation using the temperature factor.

$$C_{dt} = f_t C_d \quad \text{.....(1)}$$

where, C_{dt} : Dynamic load capacity considering temperature increase N

f_t : Temperature factor (Refer to Table 10.)

C_d : Dynamic load capacity N (Refer to the dimension tables.)

Table 10 Temperature factor f_t

Type of bushing		Temperature $^{\circ}\text{C}$					
		-30 +80	+80 +90	+90 +100	+100 +120	+120 +150	+150 +180
Steel-on-steel	Without seals	1	1	1	1	1	0.7
	With seals	1	—	—	—	—	—
Maintenance-free	Without seals	1	1	0.9	0.75	0.55	—
	With seals	1	—	—	—	—	—

2 Static load capacity

The static load capacity C_s is the maximum static load that can be applied on the spherical bushing without breaking inner and outer rings or causing any permanent deformation severe enough to render the bushing unusable.

It must be noted that if the magnitude of the applied load becomes comparable to the static load capacity of bushing, the stresses in the shaft or housing may also reach to their limits. This possibility must be taken into consideration in the design.

Equivalent radial load

Spherical Bushings can take radial and axial loads at the same time. When the magnitude and direction of loads are constant, the equivalent radial load can be obtained from the following equation.

$$P = F_r + YF_a \quad \text{.....(2)}$$

where, P : Equivalent radial load N

F_r : Radial load N

F_a : Axial load N

Y : Axial load factor (Refer to Table 11.)

Table 11 Axial load factor Y

Type of bushing	F_a/F_r					
	0.1	0.2	0.3	0.4	0.5	> 0.5
Steel-on-steel	1	2	3	4	5	Unusable
Maintenance-free	1	2	3	Unusable		

Life

The life of Spherical Bushings is defined as the total number of oscillating motions before the bushings cannot be operated normally because of wear, increase in internal clearance, increase in sliding torque, rise of operating temperature, etc.

As the actual life is affected by many factors such as the material of the sliding surface, the magnitude and direction of load, lubrication, sliding velocity, etc., the calculated life can be used as a practical measure of expected service life.

1 Life of Steel-on-steel spherical bushings

[1] Confirmation of pV value

Before attempting to calculate the life, make sure that the operating conditions are within the permissible range by referring to the pV diagram in Fig.1.

When the operating conditions are out of the permissible range, please consult IKO.

The contact pressure p and the sliding velocity V are obtained from the following equations.

$$p = \frac{100P}{C_{dt}} \quad \text{.....(3)}$$

$$V = 5.82 \times 10^{-4} d_k \beta f \quad \text{.....(4)}$$

where, p : Contact pressure N/mm²

P : Equivalent radial load N (Refer to equation (2).)

C_{dt} : Dynamic load capacity considering temperature increase N (Refer to equation (1).)

V : Sliding velocity mm/s

d_k : Sphere diameter mm

(Refer to the dimension tables.)

2β : Oscillating angle degrees (Refer to Fig.2.)

when $\beta < 5^{\circ}$, $\beta = 5$

when rotating, $\beta = 90$

f : Number of oscillations per minute min⁻¹

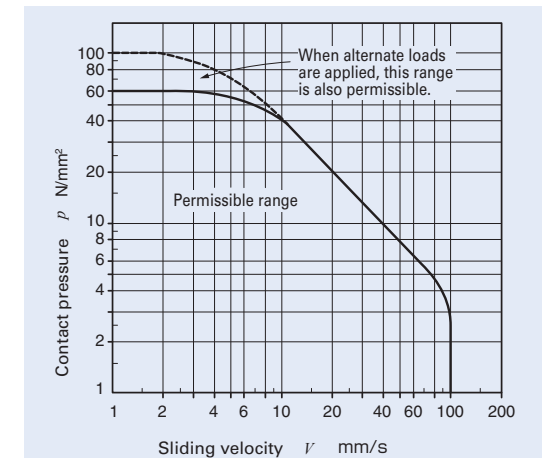


Fig.1 pV diagram of Steel-on-steel spherical bushings

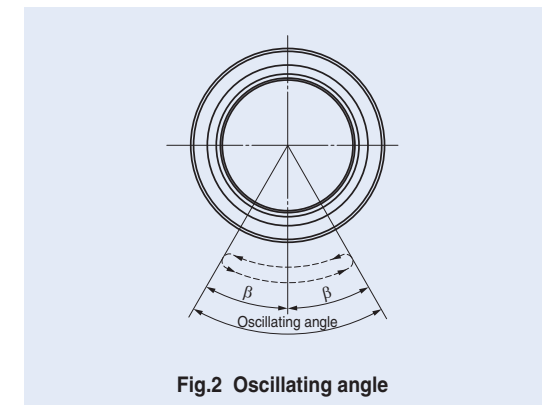


Fig.2 Oscillating angle

[2] Life calculation

The life of steel-on-steel spherical bushings can be calculated from the following equations.

$$G = \frac{3.18b_1b_2b_3}{\sqrt{d_k} \beta} \left(\frac{C_{dt}}{P}\right)^2 \times 10^5 \dots\dots\dots (5)$$

$$L_h = \frac{G}{60f} \dots\dots\dots (6)$$

- where, G : Life (Total number of oscillations)
- b_1 : Load directional factor (Refer to Table 12.)
- b_2 : Lubrication factor (Refer to Table 13.)
- b_3 : Sliding velocity factor (Refer to Fig.3.)
- C_{dt} : Dynamic load capacity considering temperature increase N
(Refer to equation (1).)
- P : Equivalent radial load N
(Refer to equation (2).)
- L_h : Life in hours h
- f : Number of oscillations per minute min^{-1}

Table 12 Load directional factor b_1 (Steel-on-steel)

Load direction	Constant	Alternate
Load directional factor b_1	1	5

Table 13 Lubrication factor b_2

Periodical lubrication	None	Regular
Lubrication factor b_2	1	15

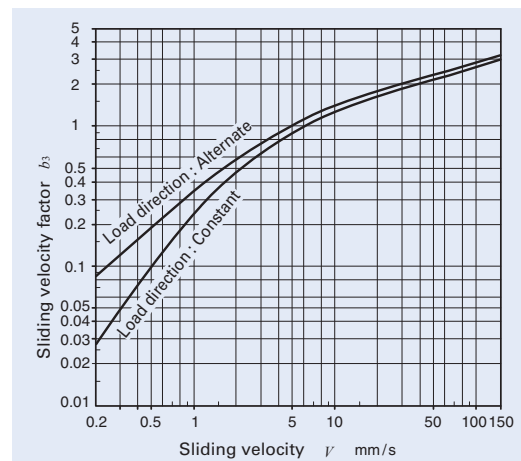


Fig.3 Sliding velocity factor

② Life of Maintenance-free spherical bushings

[1] Confirmation of pV value

Before attempting to calculate the life, make sure that the operating conditions are within the permissible range by referring to the pV diagram in Fig.4.

When the operating conditions are out of the permissible range, please consult IKO.

The contact pressure p and the sliding velocity V are obtained from equations (3) and (4) shown on page K6.

[2] Life calculation

The life of maintenance-free spherical bushings is obtained from the total sliding distance S which is given in Fig.5 for the contact pressure p obtained from equation (3).

The total number of oscillations and life in hours can be obtained from the following equations.

$$G = 16.67 \times b_1 \frac{Sf}{V} \dots\dots\dots (7)$$

$$L_h = \frac{G}{60f} \dots\dots\dots (8)$$

- where, G : Life (Total number of oscillations)
- b_1 : Load directional factor (Refer to Table 14.)
- S : Total sliding distance m (Refer to Fig.5.)
- f : Number of oscillations per minute min^{-1}
- V : Sliding velocity mm/s
- L_h : Life in hours h

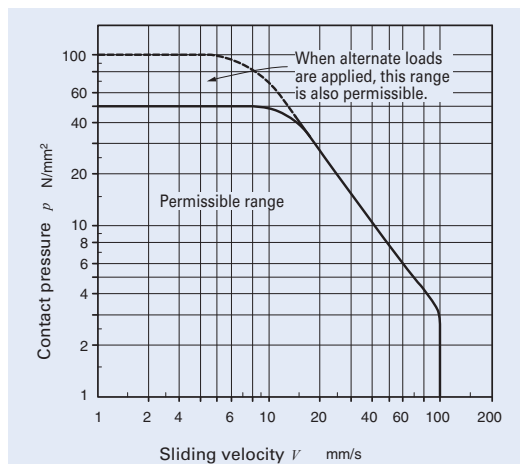


Fig.4 pV diagram of Maintenance-free spherical bushings

Table 14 Load directional factor b_1 (Maintenance-free)

Load direction	Constant	Alternate
Load directional factor b_1	1	0.2 ⁽¹⁾

Note⁽¹⁾ This value is applicable when the load changes comparatively slowly. When the load changes rapidly, please consult IKO, as the factor decreases sharply.

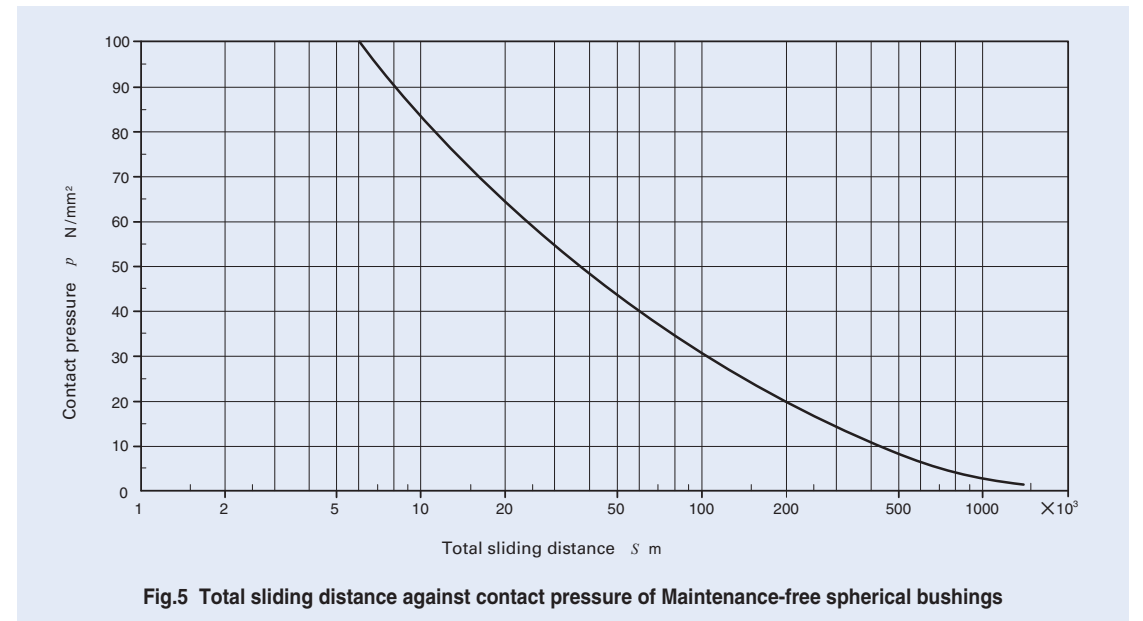


Fig.5 Total sliding distance against contact pressure of Maintenance-free spherical bushings

■ Lubrication

Steel-on-steel Spherical Bushings require periodic grease lubrication as a general rule. During initial operation, it is recommended to shorten the lubrication interval. Lithium soap based grease (NLGI consistency No.2) containing molybdenum disulfide (MoS2) is widely used as the lubrication grease. For Maintenance-free Spherical Bushings, lubrication is not required. However, supplying lithium soap based grease before operation can extend the life of the Spherical Bushing. Also, to protect the bearing from foreign substances and corrosion, it is effective to fill the area around the bearing with grease.

■ Oil Hole

The number of oil holes on inner and outer rings is shown in Table 15.

Table 15 Number of oil holes on inner and outer rings

Bushing type			Number of oil holes on inner and outer rings
Steel-on-steel Spherical Bushings	Metric series	GE...E	0
		GE...G	
	Inch series	SBB	2
		SB, SB...A, GE...ES, GE...GS	
Maintenance-free Spherical Bushings	Metric series	GE...EC	0

Remark Types with oil holes are also provided with oil grooves on inner and outer rings.

Operating Temperature Range

The operating temperature range for Spherical Bushings with seals is -30°C~+80°C. The maximum allowable temperature for Spherical Bushings without seals is +180 °C for the steel-on-steel type and +150 °C for the maintenance-free type.

Precautions for Use

Design of shaft

When the load is large, sliding may occur between the shaft and the inner ring bore of bushing. For such cases, it is necessary to prepare the shaft with a hardness of 58HRC or greater and surface roughness of 0.8 μmR_a or less. Furthermore, attention must be paid to the strength of shaft because the shear and/or bending stresses in the shaft may surpass the allowable values even when the load is below the static load capacity of Spherical Bushings.

Design of housing

The housing should have sufficient rigidity to avoid harmful deformation under load. When the housing shown in Fig.6 is used, it should be designed with sufficient strength as follows.

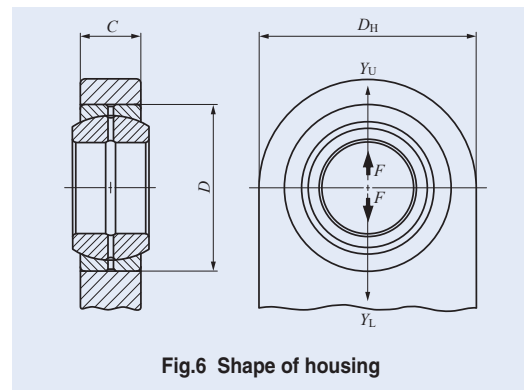


Fig.6 Shape of housing

① When the load acts in the Y_L direction;

Select the housing material considering the compressive stress obtained from the following equation.

$$\sigma_1 = \frac{F}{CD} \dots\dots\dots(9)$$

- where, σ_1 : Maximum compressive stress occurring in the housing bore N/mm²
 F : Applied load N
 C : Width of outer ring and housing mm
 D : Outside diameter of outer ring mm

② When the load acts in the Yu direction ;

Select the housing material considering the tensile stress obtained from the following equation.

$$\sigma_2 = \frac{F}{C(D_H - D)} k \dots\dots\dots(10)$$

- where, σ_2 : Maximum tensile stress occurring in the housing bore N/mm²
 F : Applied load N
 C : Width of outer ring and housing mm
 D_H : Outside diameter of housing mm
 D : Outside diameter of outer ring mm
 k : Stress concentration factor (Refer to Fig.7.)

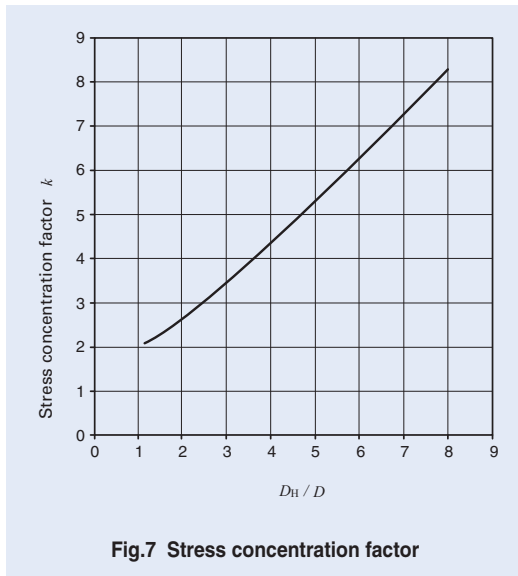


Fig.7 Stress concentration factor

Mounting

① When mounting Spherical Bushings, pay attention to the location of the split plane of the outer ring. Set the split plane at right angles to the direction of load to avoid the application of load to the split plane as shown in Fig. 8.

② The shoulder dimensions of shaft and housing are shown in the dimension tables.

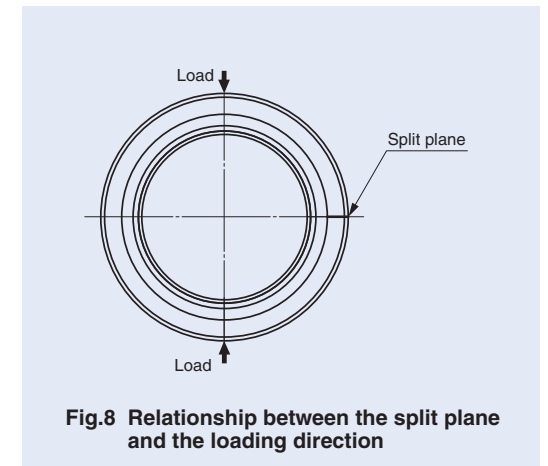


Fig.8 Relationship between the split plane and the loading direction

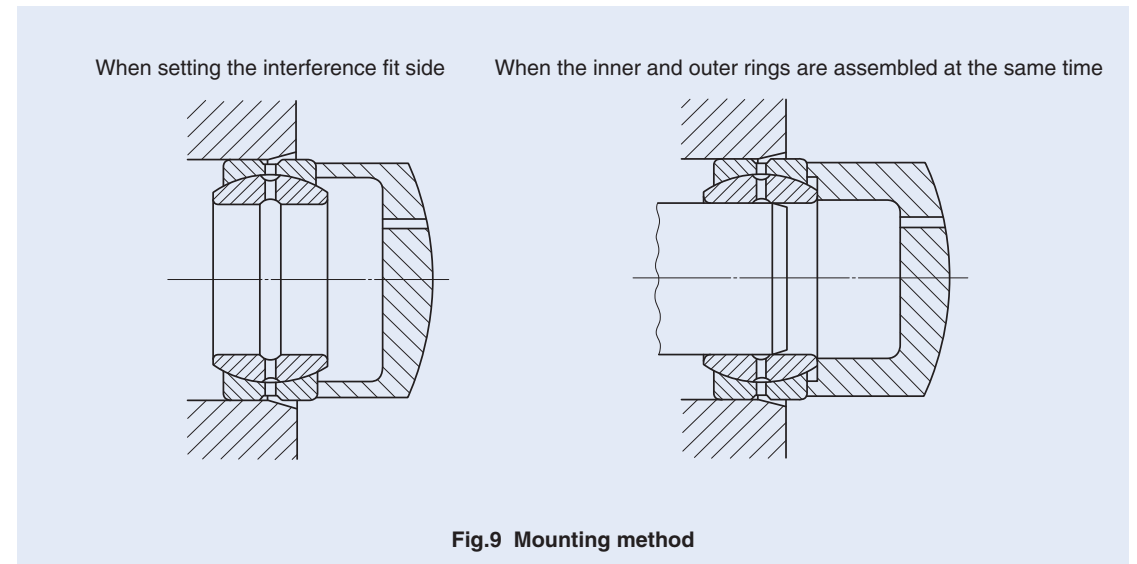


Fig.9 Mounting method

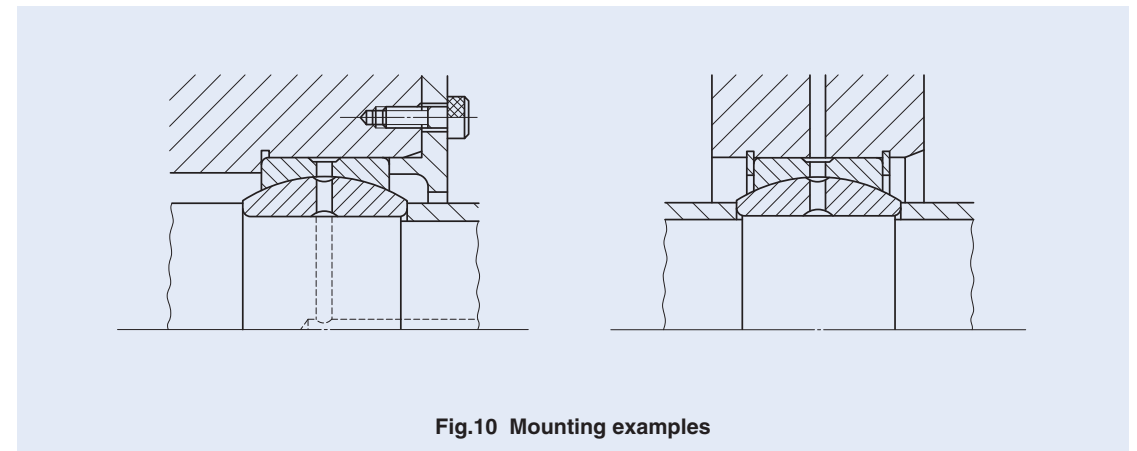


Fig.10 Mounting examples

SPHERICAL BUSHINGS

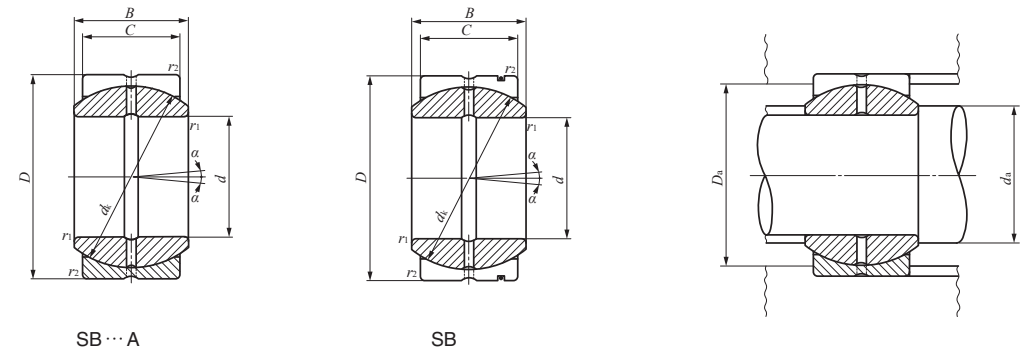
Steel-on-steel Spherical Bushings



Shaft dia. 12 – 100mm

Shaft dia. mm	Identification number		Mass (Ref.) kg	Boundary dimensions mm						Permissible tilting angle degree α
				d	D	B	C	d_k	$r_{s \text{ min}}^{(1)}$	
12	SB 12A	SB 122211	0.019	12	22	11	9	18	0.3	7
15	SB 15A	SB 152613	0.028	15	26	13	11	22	0.3	6
20	SB 20A	SB 203216	0.053	20	32	16	14	28	0.3	4
22	SB 22A	SB 223719	0.085	22	37	19	16	32	0.3	6
25	SB 25A	SB 254221	0.116	25	42	21	18	36	0.3	5
30	SB 30A	SB 305027	0.225	30	50	27	23	45	0.6	6
35	SB 35A	SB 355530	0.300	35	55	30	26	50	0.6	5
40	SB 40A	SB 406233	0.375	40	62	33	28	55	0.6	6
45	SB 45A	SB 457236	0.600	45	72	36	31	62	0.6	5
50	SB 50A	SB 508042	0.870	50	80	42	36	72	0.6	5
55	SB 55A	SB 559047	1.26	55	90	47	40	80	0.6	5
60	SB 60A	SB 6010053	1.70	60	100	53	45	90	0.6	6
65	SB 65A	SB 6510555	2.05	65	105	55	47	94	0.6	5
70	SB 70A	SB 7011058	2.22	70	110	58	50	100	0.6	5
75	SB 75A	SB 7512064	3.02	75	120	64	55	110	0.6	5
80	SB 80A	SB 8013070	3.98	80	130	70	60	120	0.6	5
85	SB 85A	SB 8513574	4.29	85	135	74	63	125	0.6	6
90	SB 90A	SB 9014076	4.71	90	140	76	65	130	0.6	5
95	SB 95A	SB 9515082	6.05	95	150	82	70	140	0.6	5
100	SB 100A	SB 10016088	7.42	100	160	88	75	150	1	5

Notes⁽¹⁾ Minimum allowable value of chamfer dimensions r_1 and r_2
⁽²⁾ When Spherical Bushings are used with full tilting angle, the shaft shoulder dimension must be less than the maximum value of d_a .
 Remarks1. The inner ring and the outer ring have an oil groove and two oil holes, respectively.
 2. No grease is prepacked. Perform proper lubrication.



Mounting dimensions mm				Dynamic load capacity C_d N	Static load capacity C_s N
d_a		D_a			
Min.	Max. ⁽²⁾	Max.	Min.		
14	14	19.5	17	15 900	95 300
17.5	17.5	23.5	21	23 700	142 000
22.5	23	29.5	26	38 400	231 000
24.5	25.5	34.5	30	50 200	301 000
27.5	29	39.5	34	63 500	381 000
34.5	36	45.5	42	101 000	609 000
39.5	40	50.5	46.5	127 000	765 000
44	44	57.5	51.5	151 000	906 000
49.5	50.5	67.5	58	188 000	1 130 000
54.5	58.5	75.5	67	254 000	1 530 000
59.5	64.5	85.5	74.5	314 000	1 880 000
64.5	72.5	95.5	83.5	397 000	2 380 000
69.5	76	100.5	87	433 000	2 600 000
74.5	81.5	105.5	93	490 000	2 940 000
79.5	89.5	115.5	102	593 000	3 560 000
84.5	97.5	125.5	112	706 000	4 240 000
89.5	100.5	130.5	116	772 000	4 630 000
94.5	105.5	135.5	121	829 000	4 970 000
99.5	113.5	145.5	130	961 000	5 770 000
105.5	121.5	154.5	139	1 100 000	6 620 000

SPHERICAL BUSHINGS

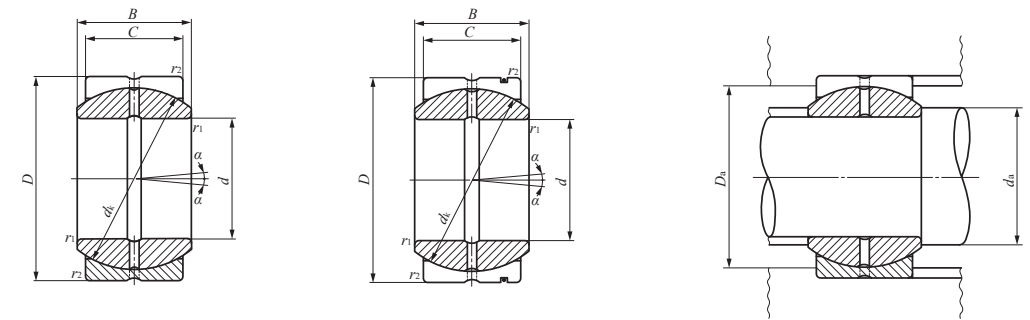
Steel-on-steel Spherical Bushings



Shaft dia. 110 – 150mm

Shaft dia. mm	Identification number		Mass (Ref.) kg	Boundary dimensions mm						Permissible tilting angle degree α
				d	D	B	C	d_k	r_s min ⁽¹⁾	
110	SB 110A	SB 11017093	8.55	110	170	93	80	160	1	5
115	SB 115A	SB 11518098	10.3	115	180	98	85	165	1	5
120	SB 120A	SB 120190105	12.4	120	190	105	90	175	1	5
130	SB 130A	SB 130200110	13.8	130	200	110	95	185	1	5
150	SB 150A	SB 150220120	17.0	150	220	120	105	205	1	5

Notes⁽¹⁾ Minimum allowable value of chamfer dimensions r_1 and r_2
⁽²⁾ When Spherical Bushings are used with full tilting angle, the shaft shoulder dimension must be less than the maximum value of d_a .
 Remarks1. The inner ring and the outer ring have an oil groove and two oil holes, respectively.
 2. No grease is prepacked. Perform proper lubrication.



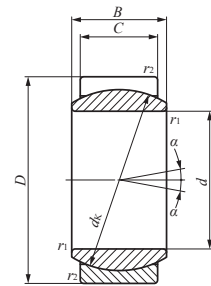
SB...A

SB

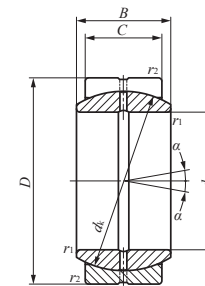
Mounting dimensions mm				Dynamic load capacity C_d N	Static load capacity C_s N
Min.	d_a Max. ⁽²⁾	Max.	D_a Min.		
115.5	130	164.5	149	1 260 000	7 530 000
120.5	132.5	174.5	152	1 380 000	8 250 000
125.5	140	184.5	162	1 540 000	9 270 000
135.5	148.5	194.5	171	1 720 000	10 300 000
155.5	166	214.5	189	2 110 000	12 700 000

SPHERICAL BUSHINGS

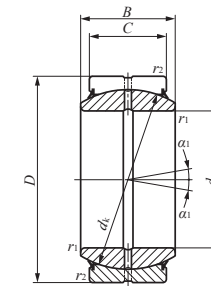
Steel-on-steel Spherical Bushings



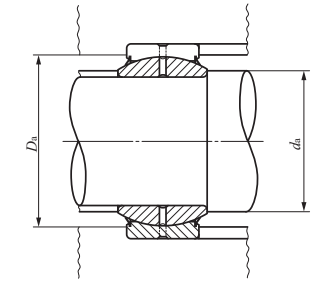
GE...E



GE...ES



GE...ES-2RS



Shaft dia. 4 – 100mm

Shaft dia. mm	Identification number		Mass (Ref.) kg	Boundary dimensions mm							Permissible tilting angle degree	
	Without seals	With seals		d	D	B	C	dk	r _{1s} ⁽¹⁾ min	r _{2s} ⁽¹⁾ min	α	α ₁
4	GE 4E	—	0.003	4	12	5	3	8	0.3	0.3	16	—
5	GE 5E	—	0.004	5	14	6	4	10	0.3	0.3	13	—
6	GE 6E	—	0.004	6	14	6	4	10	0.3	0.3	13	—
8	GE 8E	—	0.008	8	16	8	5	13	0.3	0.3	15	—
10	GE 10E	—	0.012	10	19	9	6	16	0.3	0.3	12	—
12	GE 12E	—	0.017	12	22	10	7	18	0.3	0.3	11	—
15	GE 15ES	GE 15ES-2RS	0.032	15	26	12	9	22	0.3	0.3	8	5
17	GE 17ES	GE 17ES-2RS	0.049	17	30	14	10	25	0.3	0.3	10	7
20	GE 20ES	GE 20ES-2RS	0.065	20	35	16	12	29	0.3	0.3	9	6
25	GE 25ES	GE 25ES-2RS	0.115	25	42	20	16	35.5	0.6	0.6	7	4
30	GE 30ES	GE 30ES-2RS	0.160	30	47	22	18	40.7	0.6	0.6	6	4
35	GE 35ES	GE 35ES-2RS	0.258	35	55	25	20	47	0.6	1	6	4
40	GE 40ES	GE 40ES-2RS	0.315	40	62	28	22	53	0.6	1	7	4
45	GE 45ES	GE 45ES-2RS	0.413	45	68	32	25	60	0.6	1	7	4
50	GE 50ES	GE 50ES-2RS	0.560	50	75	35	28	66	0.6	1	6	4
60	GE 60ES	GE 60ES-2RS	1.10	60	90	44	36	80	1	1	6	3
70	GE 70ES	GE 70ES-2RS	1.54	70	105	49	40	92	1	1	6	4
80	GE 80ES	GE 80ES-2RS	2.29	80	120	55	45	105	1	1	6	4
90	GE 90ES	GE 90ES-2RS	2.82	90	130	60	50	115	1	1	5	3
100	GE 100ES	GE 100ES-2RS	4.43	100	150	70	55	130	1	1	7	5

Notes⁽¹⁾ Minimum allowable value of chamfer dimensions r_1 and r_2
⁽²⁾ When Spherical Bushings are used with full tilting angle, the shaft shoulder dimension must be less than the maximum value of d_a .
 Remarks1. GE...E has no oil hole. Others are provided with an oil groove and two oil holes on the inner ring and outer ring, respectively.
 2. No grease is prepacked. Perform proper lubrication.

Mounting dimensions mm				Dynamic load capacity C_d N	Static load capacity C_s N
d_a		D_a			
Min.	Max. ⁽²⁾	Max.	Min.		
6	6	9.5	8	2 350	14 100
7.5	8	11.5	10	3 920	23 500
8	8	11.5	10	3 920	23 500
10	10	13.5	13	6 370	38 200
12.5	13	16.5	15.5	9 410	56 500
14.5	15	19.5	17	12 400	74 100
17.5	18	23.5	22.5	19 400	117 000
19.5	20.5	27.5	26	24 500	147 000
22.5	24	32.5	30.5	34 100	205 000
29	29	37.5	37	55 700	334 000
34	34	42.5	41.5	71 800	431 000
39.5	39.5	49.5	48	92 200	553 000
44.5	45	56.5	54.5	114 000	686 000
49.5	50.5	62.5	60	147 000	883 000
54.5	56	69.5	66	181 000	1 090 000
65.5	66.5	84.5	79	282 000	1 690 000
75.5	77.5	99.5	91	361 000	2 170 000
85.5	89	114.5	103	463 000	2 780 000
95.5	98	124.5	112	564 000	3 380 000
105.5	109.5	144.5	127	701 000	4 210 000

SPHERICAL BUSHINGS

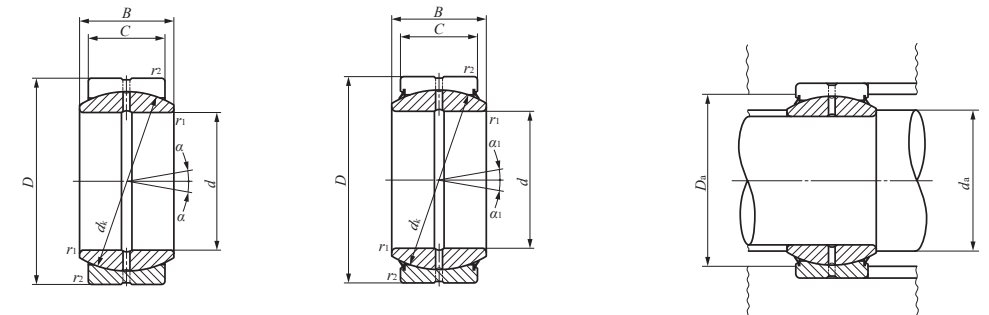
Steel-on-steel Spherical Bushings



Shaft dia. 110 – 300mm

Shaft dia. mm	Identification number		Mass (Ref.) kg	Boundary dimensions mm							Permissible tilting angle degree	
	Without seals	With seals		d	D	B	C	d_k	$r_{1s \min}^{(1)}$	$r_{2s \min}^{(1)}$	α	α_1
110	GE 110ES	GE 110ES-2RS	4.94	110	160	70	55	140	1	1	6	4
120	GE 120ES	GE 120ES-2RS	8.12	120	180	85	70	160	1	1	6	4
140	GE 140ES	GE 140ES-2RS	11.4	140	210	90	70	180	1	1	7	5
160	GE 160ES	GE 160ES-2RS	14.4	160	230	105	80	200	1	1	8	6
180	GE 180ES	GE 180ES-2RS	18.9	180	260	105	80	225	1.1	1.1	6	5
200	GE 200ES	GE 200ES-2RS	28.1	200	290	130	100	250	1.1	1.1	7	6
220	GE 220ES	GE 220ES-2RS	36.1	220	320	135	100	275	1.1	1.1	8	6
240	GE 240ES	GE 240ES-2RS	40.4	240	340	140	100	300	1.1	1.1	8	6
260	GE 260ES	GE 260ES-2RS	52.0	260	370	150	110	325	1.1	1.1	7	6
280	GE 280ES	GE 280ES-2RS	66.0	280	400	155	120	350	1.1	1.1	6	5
300	GE 300ES	GE 300ES-2RS	76.0	300	430	165	120	375	1.1	1.1	7	6

Notes⁽¹⁾ Minimum allowable value of chamfer dimensions r_1 and r_2
⁽²⁾ When Spherical Bushings are used with full tilting angle, the shaft shoulder dimension must be less than the maximum value of d_a .
 Remarks1. The inner ring and the outer ring have an oil groove and two oil holes, respectively.
 2. No grease is prepacked. Perform proper lubrication.



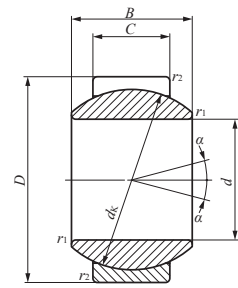
GE...ES

GE...ES-2RS

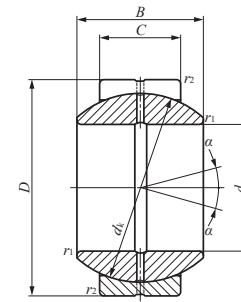
Mounting dimensions mm				Dynamic load capacity C_d N	Static load capacity C_s N
d_a		D_a			
Min.	Max. ⁽²⁾	Max.	Min.		
115.5	121	154.5	138	755 000	4 530 000
125.5	135.5	174.5	154	1 100 000	6 590 000
145.5	155.5	204.5	176	1 240 000	7 410 000
165.5	170	224.5	195	1 570 000	9 410 000
187	199	253	221	1 770 000	10 600 000
207	213.5	283	244	2 450 000	14 700 000
227	239.5	313	269	2 700 000	16 200 000
247	265	333	296	2 940 000	17 700 000
267	288	363	320	3 510 000	21 000 000
287	313.5	393	345	4 120 000	24 700 000
307	336.5	423	371	4 410 000	26 500 000

SPHERICAL BUSHINGS

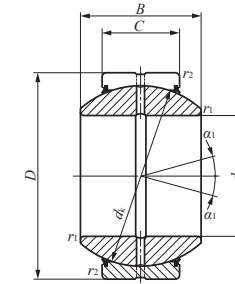
Steel-on-steel Spherical Bushings



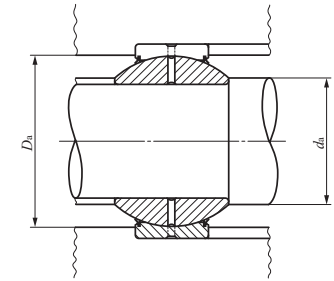
GE...G



GE...GS



GE...GS-2RS



Shaft dia. 6 – 120mm

Shaft dia. mm	Identification number		Mass (Ref.) kg	Boundary dimensions mm							Permissible tilting angle degree	
	Without seals	With seals		<i>d</i>	<i>D</i>	<i>B</i>	<i>C</i>	<i>d_k</i>	<i>r_{1s min}</i> ⁽¹⁾	<i>r_{2s min}</i> ⁽¹⁾	<i>α</i>	<i>α₁</i>
6	GE 6G	—	0.010	6	16	9	5	13	0.3	0.3	21	—
8	GE 8G	—	0.015	8	19	11	6	16	0.3	0.3	21	—
10	GE 10G	—	0.022	10	22	12	7	18	0.3	0.3	18	—
12	GE 12G	—	0.041	12	26	15	9	22	0.3	0.3	18	—
15	GE 15GS	GE 15GS-2RS	0.059	15	30	16	10	25	0.3	0.3	16	13
17	GE 17GS	GE 17GS-2RS	0.083	17	35	20	12	29	0.3	0.3	19	16
20	GE 20GS	GE 20GS-2RS	0.155	20	42	25	16	35.5	0.3	0.6	17	16
25	GE 25GS	GE 25GS-2RS	0.215	25	47	28	18	40.7	0.6	0.6	17	15
30	GE 30GS	GE 30GS-2RS	0.330	30	55	32	20	47	0.6	1	17	16
35	GE 35GS	GE 35GS-2RS	0.400	35	62	35	22	53	0.6	1	16	15
40	GE 40GS	GE 40GS-2RS	0.515	40	68	40	25	60	0.6	1	17	14
45	GE 45GS	GE 45GS-2RS	0.660	45	75	43	28	66	0.6	1	15	13
50	GE 50GS	GE 50GS-2RS	1.50	50	90	56	36	80	0.6	1	17	16
60	GE 60GS	GE 60GS-2RS	2.05	60	105	63	40	92	1	1	17	15
70	GE 70GS	GE 70GS-2RS	3.00	70	120	70	45	105	1	1	16	14
80	GE 80GS	GE 80GS-2RS	3.60	80	130	75	50	115	1	1	14	13
90	GE 90GS	GE 90GS-2RS	5.41	90	150	85	55	130	1	1	15	14
100	GE 100GS	GE 100GS-2RS	6.15	100	160	85	55	140	1	1	14	12
110	GE 110GS	GE 110GS-2RS	9.70	110	180	100	70	160	1	1	12	11
120	GE 120GS	GE 120GS-2RS	15.5	120	210	115	70	180	1	1	16	15

Notes⁽¹⁾ Minimum allowable value of chamfer dimensions *r₁* and *r₂*
⁽²⁾ When Spherical Bushings are used with full tilting angle, the shaft shoulder dimension must be less than the maximum value of *d_a*.
 Remarks1. GE...G has no oil hole. Others are provided with an oil groove and two oil holes on the inner ring and outer ring, respectively.
 2. No grease is prepacked. Perform proper lubrication.

Mounting dimensions mm				Dynamic load capacity <i>C_d</i> N	Static load capacity <i>C_s</i> N
<i>d_a</i>		<i>D_a</i>			
Min.	Max. ⁽²⁾	Max.	Min.		
8.5	9	13.5	13	6 370	38 200
10.5	11.5	16.5	15.5	9 410	56 500
12.5	13	19.5	17	12 400	74 100
14.5	16	23.5	21	19 400	117 000
17.5	19	27.5	26	24 500	147 000
19.5	21	32.5	30.5	34 100	205 000
22.5	25	37.5	37	55 700	334 000
29.5	29.5	42.5	41.5	71 800	431 000
34	34	49.5	48	92 200	553 000
39.5	39.5	56.5	54.5	114 000	686 000
44.5	44.5	62.5	60	147 000	883 000
49.5	50	69.5	66	181 000	1 090 000
54.5	57	84.5	79	282 000	1 690 000
65.5	67	99.5	91	361 000	2 170 000
75.5	78	114.5	103	463 000	2 780 000
85.5	87	124.5	112	564 000	3 380 000
95.5	98	144.5	127	701 000	4 210 000
105.5	111	154.5	138	755 000	4 530 000
115.5	124.5	174.5	154	1 100 000	6 590 000
125.5	138.5	204.5	176	1 240 000	7 410 000

SPHERICAL BUSHINGS

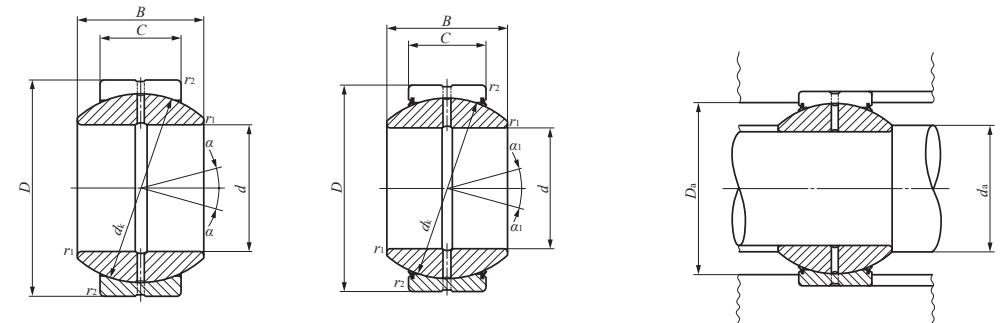
Steel-on-steel Spherical Bushings



Shaft dia. 140 – 280mm

Shaft dia. mm	Identification number		Mass (Ref.) kg	Boundary dimensions mm							Permissible tilting angle degree	
	Without seals	With seals		d	D	B	C	d_k	$r_{1s \min}^{(1)}$	$r_{2s \min}^{(1)}$	α	α_1
140	GE 140GS	GE 140GS-2RS	19.2	140	230	130	80	200	1	1	16	15
160	GE 160GS	GE 160GS-2RS	25.4	160	260	135	80	225	1	1.1	16	14
180	GE 180GS	GE 180GS-2RS	34.7	180	290	155	100	250	1.1	1.1	14	13
200	GE 200GS	GE 200GS-2RS	43.8	200	320	165	100	275	1.1	1.1	15	14
220	GE 220GS	GE 220GS-2RS	51.3	220	340	175	100	300	1.1	1.1	16	14
240	GE 240GS	GE 240GS-2RS	66.1	240	370	190	110	325	1.1	1.1	15	14
260	GE 260GS	GE 260GS-2RS	81.8	260	400	205	120	350	1.1	1.1	15	14
280	GE 280GS	GE 280GS-2RS	97.4	280	430	210	120	375	1.1	1.1	15	14

Notes⁽¹⁾ Minimum allowable value of chamfer dimensions r_1 and r_2
⁽²⁾ When Spherical Bushings are used with full tilting angle, the shaft shoulder dimension must be less than the maximum value of d_a .
 Remarks1. The inner ring and the outer ring have an oil groove and two oil holes, respectively.
 2. No grease is prepacked. Perform proper lubrication.



GE...GS

GE...GS-2RS

Mounting dimensions mm				Dynamic load capacity C_d N	Static load capacity C_s N
d_a		D_a			
Min.	Max. ⁽²⁾	Max.	Min.		
145.5	152	224.5	195	1 570 000	9 410 000
165.5	180	253	221	1 770 000	10 600 000
187	196	283	244	2 450 000	14 700 000
207	220	313	269	2 700 000	16 200 000
227	243.5	333	296	2 940 000	17 700 000
247	263.5	363	320	3 510 000	21 000 000
267	283.5	393	345	4 120 000	24 700 000
287	310.5	423	371	4 410 000	26 500 000

SPHERICAL BUSHINGS

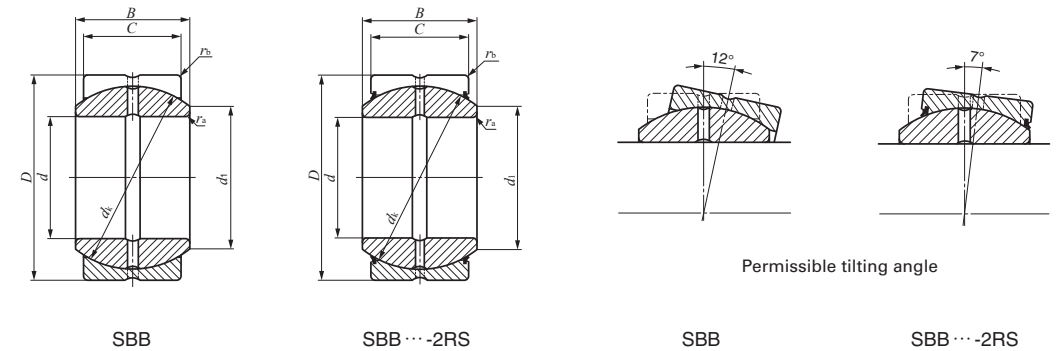
Steel-on-steel Spherical Bushings **Inch Series**



Shaft dia. 12.700 – 63.500mm

Shaft dia. mm (inch)	Identification number		Mass (Ref.) kg	Boundary dimensions mm(inch)			
	Without seal	With seals		<i>d</i>	<i>D</i>	<i>B</i>	<i>C</i>
12.700 (1/2)	SBB 8	—	0.020	12.700 (1/2)	22.225 (7/8)	11.10(.437)	9.52(.375)
15.875 (5/8)	SBB 10	—	0.036	15.875 (5/8)	26.988 (1 1/16)	13.89(.547)	11.91(.469)
19.050 (3/4)	SBB 12	SBB 12-2RS	0.057	19.050 (3/4)	31.750 (1 1/4)	16.66(.656)	14.27(.562)
22.225 (7/8)	SBB 14	SBB 14-2RS	0.088	22.225 (7/8)	36.512 (1 7/16)	19.43(.765)	16.66(.656)
25.400 (1)	SBB 16	SBB 16-2RS	0.125	25.400 (1)	41.275 (1 5/8)	22.22(.875)	19.05(.750)
31.750 (1 1/4)	SBB 20	SBB 20-2RS	0.234	31.750 (1 1/4)	50.800 (2)	27.76(1.093)	23.80(.937)
34.925 (1 3/8)	SBB 22	SBB 22-2RS	0.349	34.925 (1 3/8)	55.562 (2 3/16)	30.15(1.187)	26.19(1.031)
38.100 (1 1/2)	SBB 24	SBB 24-2RS	0.424	38.100 (1 1/2)	61.912 (2 7/16)	33.32(1.312)	28.58(1.125)
44.450 (1 3/4)	SBB 28	SBB 28-2RS	0.649	44.450 (1 3/4)	71.438 (2 13/16)	38.89(1.531)	33.32(1.312)
50.800 (2)	SBB 32	SBB 32-2RS	0.939	50.800 (2)	80.962 (3 3/16)	44.45(1.750)	38.10(1.500)
57.150 (2 1/4)	SBB 36	SBB 36-2RS	1.32	57.150 (2 1/4)	90.488 (3 9/16)	50.01(1.969)	42.85(1.687)
63.500 (2 1/2)	SBB 40	SBB 40-2RS	1.85	63.500 (2 1/2)	100.012 (3 15/16)	55.55(2.187)	47.62(1.875)

Note(1) Maximum allowable corner radius of the shaft or housing
 Remarks1. The value with mark * is applicable to types without seals. For types with seals, the value is 0.4 mm.
 2. The inner ring and the outer ring have an oil groove and two oil holes, respectively.
 3. No grease is prepacked. Perform proper lubrication.



<i>d_k</i>	Radial internal clearance mm Min./Max.	Mounting dimensions mm			Dynamic load capacity <i>C_d</i> N	Static load capacity <i>C_s</i> N
		<i>d₁</i>	⁽¹⁾ <i>r_{as} max</i> Max.	⁽¹⁾ <i>r_{bs} max</i> Max.		
18 (.709)	0.05 / 0.15	14.0	0.2	0.6	16 800	101 000
23 (.906)	0.05 / 0.15	17.9	0.2	0.8	26 900	161 000
27.5(1.083)	0.08 / 0.18	21.4	0.6	*0.8	38 500	231 000
32 (1.260)	0.08 / 0.18	25.0	0.6	*0.8	52 300	314 000
36 (1.417)	0.08 / 0.18	28.0	0.6	*0.8	67 300	404 000
45 (1.772)	0.08 / 0.18	35.1	0.6	0.8	105 000	630 000
49 (1.929)	0.08 / 0.18	38.5	0.6	0.8	126 000	755 000
55 (2.165)	0.08 / 0.18	43.3	0.6	0.8	154 000	925 000
64 (2.520)	0.08 / 0.18	50.4	0.6	0.8	209 000	1 250 000
73 (2.874)	0.08 / 0.18	57.6	0.6	0.8	273 000	1 640 000
82 (3.228)	0.10 / 0.20	64.9	0.6	0.8	345 000	2 070 000
91 (3.583)	0.10 / 0.20	72.0	0.6	0.8	425 000	2 550 000

SPHERICAL BUSHINGS

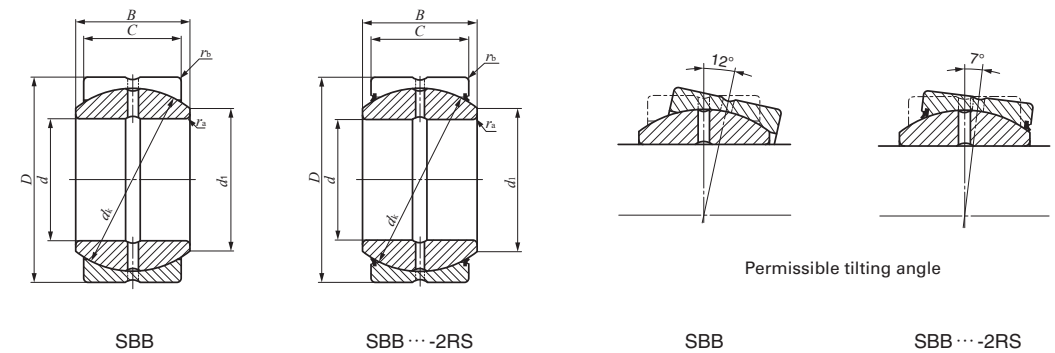
Steel-on-steel Spherical Bushings **Inch Series**



Shaft dia. 69.850 – 152.400mm

Shaft dia. mm (inch)	Identification number		Mass (Ref.) kg	Boundary dimensions mm(inch)			
	Without seal	With seals		<i>d</i>	<i>D</i>	<i>B</i>	<i>C</i>
69.850 (2¾)	SBB 44	SBB 44-2RS	2.44	69.850 (2¾)	111.125 (4¾)	61.11(2.406)	52.37(2.062)
76.200 (3)	SBB 48	SBB 48-2RS	3.12	76.200 (3)	120.650 (4¾)	66.68(2.625)	57.15(2.250)
82.550 (3¼)	SBB 52	SBB 52-2RS	3.92	82.550 (3¼)	130.175 (5¼)	72.24(2.844)	61.90(2.437)
88.900 (3½)	SBB 56	SBB 56-2RS	4.83	88.900 (3½)	139.700 (5½)	77.77(3.062)	66.68(2.625)
95.250 (3¾)	SBB 60	SBB 60-2RS	5.87	95.250 (3¾)	149.225 (5¾)	83.34(3.281)	71.42(2.812)
101.600 (4)	SBB 64	SBB 64-2RS	7.07	101.600 (4)	158.750 (6¼)	88.90(3.500)	76.20(3.000)
107.950 (4¼)	SBB 68	SBB 68-2RS	8.46	107.950 (4¼)	168.275 (6⅝)	94.46(3.719)	80.95(3.187)
114.300 (4½)	SBB 72	SBB 72-2RS	9.94	114.300 (4½)	177.800 (7)	100.00(3.937)	85.72(3.375)
120.650 (4¾)	SBB 76	SBB 76-2RS	11.6	120.650 (4¾)	187.325 (7¾)	105.56(4.156)	90.47(3.562)
127.000 (5)	SBB 80	SBB 80-2RS	13.5	127.000 (5)	196.850 (7¾)	111.12(4.375)	95.25(3.750)
152.400 (6)	SBB 96	SBB 96-2RS	17.6	152.400 (6)	222.250 (8¾)	120.65(4.750)	104.78(4.125)

Note(1) Maximum allowable corner radius of the shaft or housing
 Remarks1. The inner ring and the outer ring have an oil groove and two oil holes, respectively.
 2. No grease is prepacked. Perform proper lubrication.



<i>d_k</i>	Radial internal clearance mm Min./Max.	Mounting dimensions mm			Dynamic load capacity <i>C_d</i> N	Static load capacity <i>C_s</i> N
		<i>d₁</i>	⁽¹⁾ <i>r_{as} max</i> Max.	⁽¹⁾ <i>r_{bs} max</i> Max.		
100(3.937)	0.10 / 0.20	79.0	0.6	0.8	514 000	3 080 000
110(4.331)	0.10 / 0.20	86.5	0.6	0.8	616 000	3 700 000
119(4.685)	0.13 / 0.23	94.1	0.6	0.8	722 000	4 330 000
128(5.039)	0.13 / 0.23	101.6	0.6	0.8	837 000	5 020 000
137(5.394)	0.13 / 0.23	108.4	0.6	0.8	960 000	5 760 000
146(5.748)	0.13 / 0.23	115.8	0.6	0.8	1 090 000	6 550 000
155(6.102)	0.13 / 0.23	122.6	0.8	1.1	1 230 000	7 380 000
164(6.457)	0.13 / 0.23	129.8	0.8	1.1	1 380 000	8 270 000
173(6.811)	0.13 / 0.23	136.8	0.8	1.1	1 530 000	9 210 000
183(7.205)	0.13 / 0.23	144.9	0.8	1.1	1 710 000	10 300 000
207(8.150)	0.13 / 0.23	167.5	0.8	1.1	2 130 000	12 800 000

SPHERICAL BUSHINGS

Maintenance-free Spherical Bushings



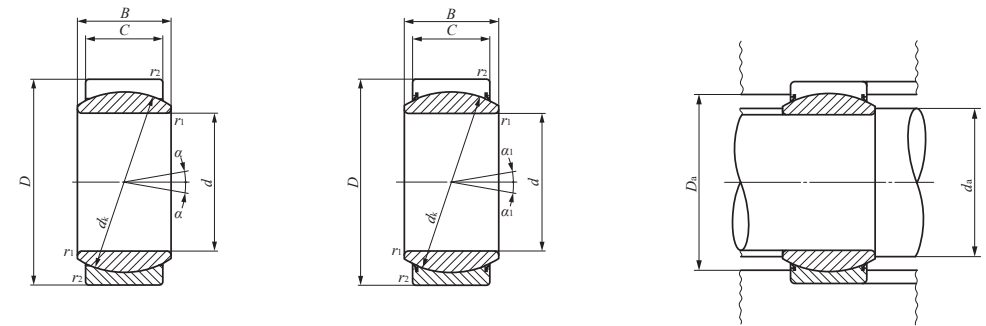
Shaft dia. 15 – 70mm

Shaft dia. mm	Identification number		Mass (Ref.) kg	Boundary dimensions mm							Permissible tilting angle degree	
	Without seals	With seals		d	D	B	C	d_k	$r_{1s \min}^{(1)}$	$r_{2s \min}^{(1)}$	α	α_1
15	GE 15EC	—	0.032	15	26	12	9	22	0.3	0.3	8	—
17	GE 17EC	—	0.049	17	30	14	10	25	0.3	0.3	10	—
20	GE 20EC	—	0.065	20	35	16	12	29	0.3	0.3	9	—
25	GE 25EC	—	0.115	25	42	20	16	35.5	0.6	0.6	7	—
30	GE 30EC	GE 30EC-2RS	0.160	30	47	22	18	40.7	0.6	0.6	6	4
35	—	GE 35EC-2RS	0.258	35	55	25	20	47	0.6	1	—	4
40	—	GE 40EC-2RS	0.315	40	62	28	22	53	0.6	1	—	4
45	—	GE 45EC-2RS	0.413	45	68	32	25	60	0.6	1	—	4
50	—	GE 50EC-2RS	0.560	50	75	35	28	66	0.6	1	—	4
60	—	GE 60EC-2RS	1.10	60	90	44	36	80	1	1	—	3
70	—	GE 70EC-2RS	1.54	70	105	49	40	92	1	1	—	4

Notes⁽¹⁾ Minimum allowable value of chamfer dimensions r_1 and r_2

⁽²⁾ When Spherical Bushings are used with full tilting angle, the shaft shoulder dimension must be less than the maximum value of d_a .

Remark No oil hole is provided.



GE...EC

GE...EC-2RS

Mounting dimensions mm				Dynamic load capacity C_d N	Static load capacity C_s N
d_a		D_a			
Min.	Max. ⁽²⁾	Max.	Min.		
17.5	18	23.5	21.5	19 400	48 500
19.5	20.5	27.5	24.5	24 500	61 300
22.5	24	32.5	28	34 100	85 300
29	29	37.5	34	55 700	139 000
34	34	42.5	41.5	71 800	180 000
39.5	39.5	49.5	48	92 200	230 000
44.5	45	56.5	54.5	114 000	286 000
49.5	50.5	62.5	60	147 000	368 000
54.5	56	69.5	66	181 000	453 000
65.5	66.5	84.5	79	282 000	706 000
75.5	77.5	99.5	91	361 000	902 000

PILLOBALLS

- PILLOBALL Spherical Bushings - Insert Type
- PILLOBALL Rod Ends - Insert Type
- PILLOBALL Rod Ends - Die-cast Type
- PILLOBALL Rod Ends - Maintenance-free Type

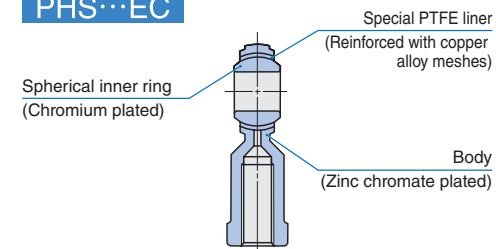


Structure and Features

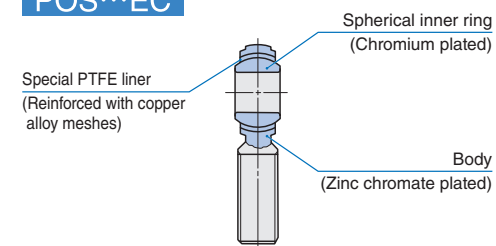
IKO PILLOBALLS are compact self-aligning spherical bushings that can support a large radial load and a bi-directional axial load at the same time. These bushings are classified by sliding surface types, namely, insert type, die-cast type and maintenance-free type. In the insert type, a spherical inner ring makes contact with the special copper alloy bushing with superior run-in properties. In the die-cast type, a spherical inner ring makes direct contact with the bore surface of the body of special zinc die-cast alloy. In the maintenance-free type, a spherical inner ring makes contact with the special PTFE liner of maintenance-free type. Thus, a smooth rotational and oscillatory motion can be achieved with superior anti-wear and loading properties in each type. PILLOBALL Rod Ends have either a female thread in the body or a male thread on the body, and they can be easily assembled onto machines. PILLOBALLS are used in control and link mechanisms in machine tools, textile machines, packaging machines, etc. The maintenance-free type is especially suitable for loading in one direction and is the best choice for machines in which oil must be avoided such as food processing machines, or machines which cannot be re-lubricated.

Structures of maintenance-free type PILLOBALLS

PHS···EC

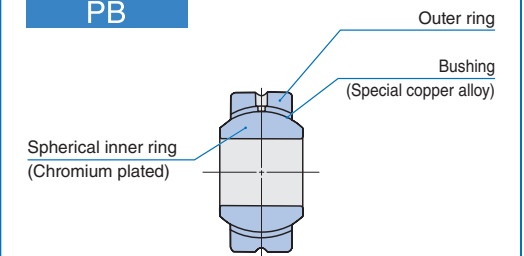


POS···EC

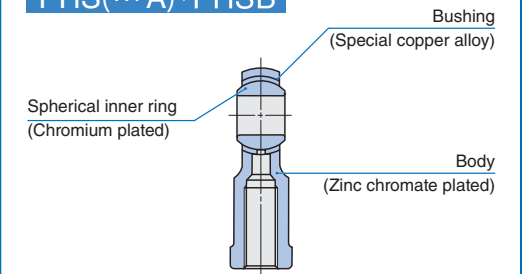


Structures of lubrication type PILLOBALLS

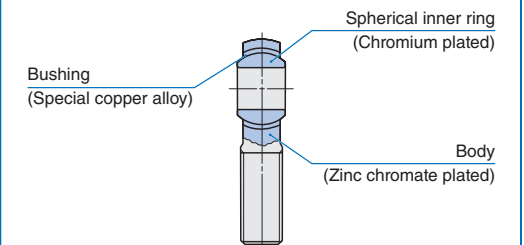
PB



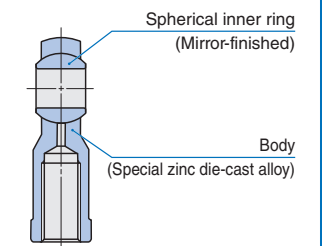
PHS(···A)·PHSB



POS(···A)·POSB



PHSA



K

PB
PHS
PHSB
POS
POSB
PHSA

Types

In PILLOBALLs, the types shown in Table 1 are available.

Table 1 Type

Type	Lubrication type		Maintenance-free type		
	Spherical Bushings	Rod end	Rod end		
Insert type	PB	PHS(---A) · PHSB	POS(---A) · POSB	PHS...EC	POS...EC
Die-cast type	—	PHSA	—	PHS...EC	POS...EC

Lubrication Type PILLOBALL Spherical Bushings Insert Type PB

This type has superior anti-wear properties and high rigidity. It consists of a spherical inner ring, an outer ring, and a bushing of special copper alloy with superior run-in properties inserted in between. The spherical surface of the inner ring is chromium plated after heat treatment and grinding. This type is assembled with a shaft and a housing.

When especially large radial and/or axial loads are applied, Spherical Bushings with molybdenum disulfide (MoS₂) treated inner and outer rings are recommended. (See page K1.)

Lubrication Type PILLOBALL Rod Ends Insert Type PHS(---A), POS(---A), PHSB and POSB

This type has superior wear-resistant and corrosion-resistant properties as well as high rigidity. It consists of a spherical inner ring of which the spherical surface is chromium plated after heat treatment and grinding, a body with a zinc chromate plated outer surface, and an inserted bushing of special copper alloy having superior run-in properties. PHS, which has a female thread in the body, and POS, which has a male thread on the body, are available. For PHS and POS sizes 5 to 18, an A is appended after the dimensions as a model code.

Lubrication Type PILLOBALL Rod Ends Die-cast Type PHSA

The spherical inner ring of this type is mirror-finished after heat treatment and is built in a body of special zinc die-cast alloy. The sliding surfaces of the inner ring and body are in close contact with each other. Thus, this type is an economical rod end with superior anti-wear and loading properties.

Maintenance-free Type PILLOBALL Rod Ends PHS...EC, POS...EC

This type has superior anti-corrosion properties as the

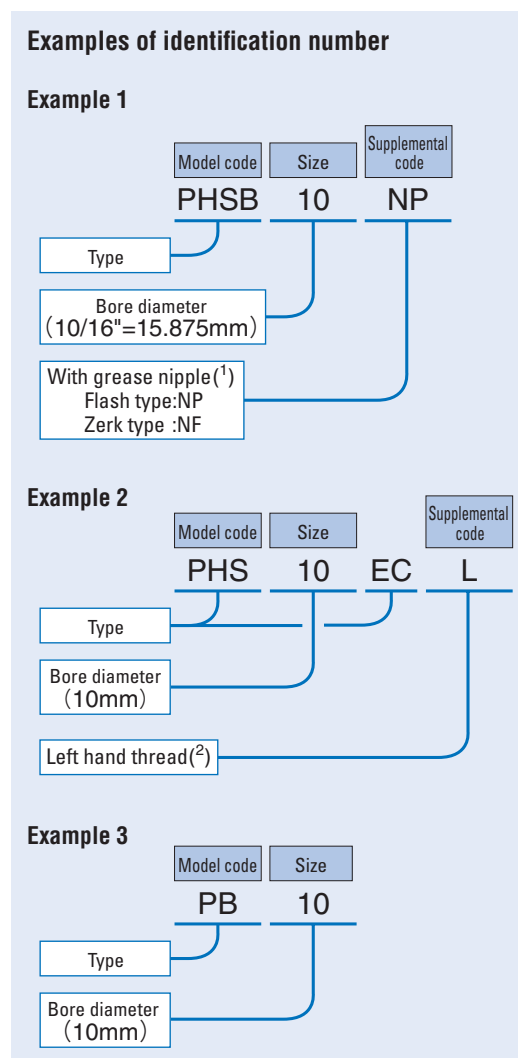
body is zinc chromate treated and the spherical inner ring is chromium plated on the sphere surface after heat treatment and grinding.

A special PTFE liner, reinforced with copper alloy meshes, which is superior in anti-wear properties with little creep deformation is used for lining on the sliding surface of the body, and this type is maintenance-free.

PHS...EC, which has a female thread in the body, and POS...EC, which has a male thread on the body, are available.

Identification number

The identification number of PILLOBALLs consists of a model code, a size and any supplemental codes as shown in the examples.



Notes⁽¹⁾ Shapes of grease nipple are shown in Fig.1. In case of no indication of grease nipple type, grease nipple is not prepared.
⁽²⁾ Right hand thread is indicated with no code.

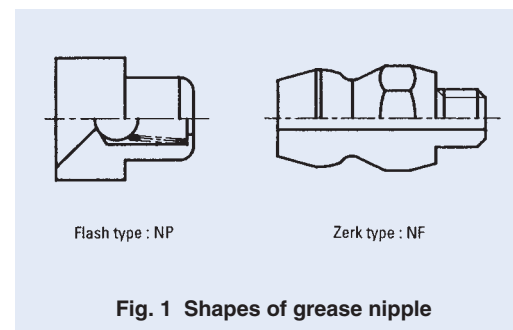


Fig. 1 Shapes of grease nipple

Accuracy

The accuracy of PILLOBALLs is shown in Tables 2 and 3. The maximum radial internal clearance of the insert type is 0.035 mm.

Table 2 Tolerance unit: mm

Type	Dimension	Dimension symbol	Tolerance
PB	Bore dia. of inner ring	<i>d</i>	H7
	Outside dia. of outer ring	<i>D</i>	h6
	Width of inner ring	<i>B</i>	0 - 0.1
	Width of outer ring	<i>C</i>	± 0.1
PHS(---A) POS(---A) PHS...EC POS...EC	Bore dia. of inner ring	<i>d</i>	H7
	Width of inner ring	<i>B</i>	0 - 0.1
	PHSB POSB	Bore dia. of inner ring	<i>d</i>
Width of inner ring		<i>B</i> ₁	0 - 0.127
PHSA	Bore dia. of inner ring	<i>d</i>	+ 0.063 - 0.012
	Width of inner ring	<i>B</i>	See Table 3.

Table 3 Tolerance of width *B* of inner ring of PHSA type unit: mm

Nominal bore dia. of inner ring	Δ_{Bs} Deviation of a single inner ring width			
	Over	Incl.	High	Low
—	14	0	— 0.2	—
14	20	0	— 0.3	—
20	22	0	— 0.4	—

Fit

Recommended fits for PILLOBALLs are shown in Table 4.

Table 4 Recommended fits

Condition	Tolerance class	
	Shaft	Housing bore ⁽¹⁾
Normal operation	h7	H7
Directionally indeterminate loading	n6, p6	N7

Note⁽¹⁾ This is applicable to PILLOBALL Spherical Bushings, Insert type.

Selection of PILLOBALL

Load capacities of PILLOBALLs are determined based on the allowable contact pressure on sliding surfaces and the strength of body for each type. Thus, a suitable type and size should be selected based on the dynamic load capacity *C_d* and static load capacity *C_s* shown in the dimension tables.

Load capacity

① Dynamic load capacity

The dynamic load capacity *C_d* is obtained on the basis of the contact pressure on the sliding surface. The dynamic load capacity is used for calculating the life.

The dynamic load capacity considering temperature increase is obtained from the following equation using the temperature factor, which is a correction factor for the effect of PILLOBALL temperature.

$$C_{dt} = f_t C_d \quad \text{.....(1)}$$

where, *C_{dt}*: Dynamic load capacity considering temperature increase, N

f_t: Temperature factor (Refer to Table 5.)

C_d: Dynamic load capacity, N (Refer to the dimension tables.)

Table 5 Temperature factor *f_t*

Type	Temperature °C					
	- 30 + 80	+ 80 + 90	+ 90 + 100	+ 100 + 120	+ 120 + 150	+ 150 + 180
PB PHS(---A), POS(---A) PHSB, POSB	1	1	1	1	1	0.7
PHS...EC POS...EC	1	1	0.9	0.75	0.55	—

② Static load capacity

The static load capacity *C_s* is the maximum static load that can be applied on the PILLOBALL without breaking the inner or outer ring of the PILLOBALL Spherical Bushing (or the inner ring or body of the PILLOBALL Rod End), and without causing severe permanent deformation that will make the PILLOBALL unusable.



Maximum Operating Load

The recommended value of bushing load is obtained by multiplying the dynamic load capacity C_d by a numerical factor, which differs depending on the bushing type and load condition. For PILLOBALL Rod Ends, the static load capacity C_s must also be considered in determining the applicable bushing load. Table 6 shows the guidelines for maximum operating load of PILLOBALLS. When axial loads are added in addition to radial loads, bending stress occurs in the body. Pay attention to this bending stress.

Table 6 Maximum operating load

Type	Load direction	
	Constant	Alternate
PB	$\leq 0.3C_d$	$\leq 0.6C_d$
PHS(-A), POS(-A), PHSB, POSB	$\leq 0.3C_d$	$\leq 0.2C_s$
PHSA	$\leq 0.16C_s$	
PHS...EC, POS...EC	$\leq 0.3C_s$	$\leq 0.2C_s$

Remark C_d is the dynamic load capacity and C_s is the static load capacity.

Equivalent radial load

PILLOBALLS can take radial and axial loads at the same time. When the magnitude and direction of loads are constant, the equivalent radial load can be obtained by the following equation.

$$P = F_r + YF_a \quad (2)$$

where, P : Equivalent radial load, N
 F_r : Radial load, N
 F_a : Axial load, N
 Y : Axial load factor (Refer to Table 7.)

Table 7 Axial load factor Y

Type	F_a/F_r					
	0.1	0.2	0.3	0.4	0.5	> 0.5
PB	1	2	3	4	5	Unusable
PHS(-A), POS(-A) PHSB, POSB	1	2	3	Unusable		
PHS...EC POS...EC	1	2	3	Unusable		

Life

The life of PILLOBALLS is defined as the total number of oscillating motions during which the PILLOBALLS can be operated without failure or malfunction due to wear, increase in internal clearance, increase in sliding torque and operating temperature, etc.

As the actual life is affected by many factors such as the material of the sliding surface, the magnitude and direction of load, lubrication, sliding velocity, etc., the calculated life can be used as a measure of expected service life.

① Life of lubrication type PILLOBALLS
PB · PHS(…A) · POS(…A) · PHSB · POSB

[1] Confirmation of pV value
 Before attempting to calculate the life, make sure that the operating conditions are within the permissible range by referring to the pV diagram in Fig.2.

When the operating conditions are out of the permissible range, please consult IKO.

The contact pressure p and the sliding velocity V are obtained from the following equations.

$$p = \frac{50P}{C_{dt}} \quad (3)$$

$$V = 5.82 \times 10^{-4} d_k \beta f \quad (4)$$

where, p : Contact pressure, N/mm²

P : Equivalent radial load, N

(Refer to equation (2).)

C_{dt} : Dynamic load capacity considering temperature increase, N

(Refer to equation (1).)

V : Sliding velocity, mm/s

d_k : Sphere diameter, mm

(Refer to the dimensional tables.)

2β : Oscillating angle degrees (Refer to Fig.3.)

when $\beta < 5^\circ$, $\beta = 5$

when rotating, $\beta = 90$

f : Number of oscillations per minute, min⁻¹

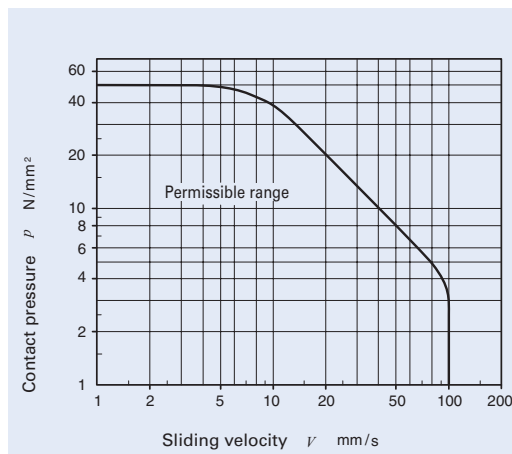


Fig. 2 pV diagram of lubrication type PILLOBALLS

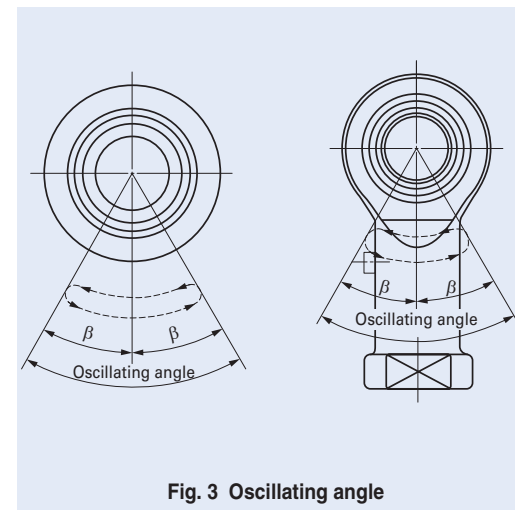


Fig. 3 Oscillating angle

[2] Life calculation

The life of lubrication type PILLOBALLS can be calculated by the following equations.

$$G = \frac{3.18b_1b_2b_3}{\sqrt{d_k \beta}} \left(\frac{C_{dt}}{P}\right)^2 \times 10^5 \quad (5)$$

$$L_h = \frac{G}{60f} \quad (6)$$

where, G : Life (Total number of oscillations)

b_1 : Load directional factor (Refer to Table 8.)

b_2 : Lubrication factor (Refer to Table 8.)

b_3 : Sliding velocity factor (Refer to Fig. 4.)

C_{dt} : Dynamic load capacity considering temperature increase, N

(Refer to equation (1).)

P : Equivalent radial load, N

(Refer to equation (2).)

L_h : Life in hours, h

f : Number of oscillations per minute, min⁻¹

Table 8 Load directional factor b_1 and lubrication factor b_2 for lubrication type PILLOBALLS

Load directional factor b_1		Lubrication factor b_2	
Load direction		Periodical lubrication	
Constant	Alternate	None	Regular
1	5	1	15

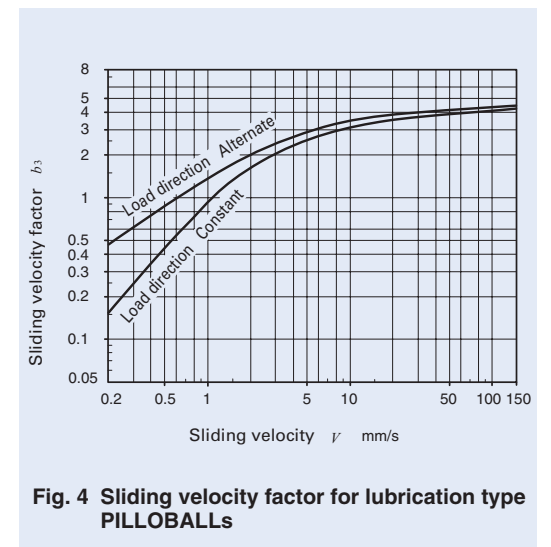


Fig. 4 Sliding velocity factor for lubrication type PILLOBALLS

② Life of maintenance-free type PILLOBALLS PHS...EC · POS...EC

[1] Confirmation of pV value

Before attempting to calculate the life, make sure that the operating conditions are within the permissible range by referring to the pV diagram in Fig.5.

When the operating conditions are out of the permissible range, please consult IKO.

The contact pressure p and sliding velocity V are obtained from equations (3) and (4).

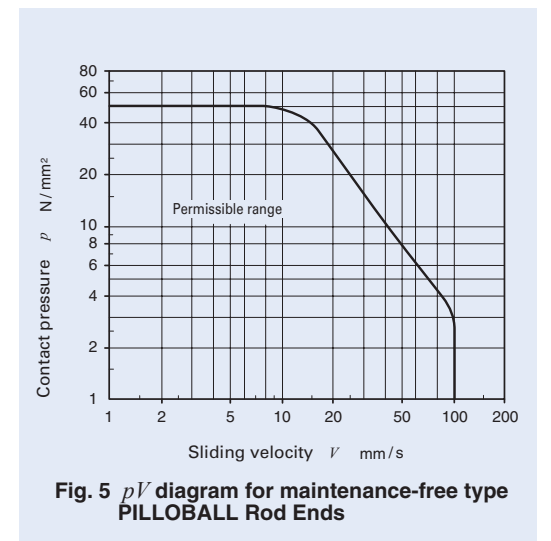


Fig. 5 pV diagram for maintenance-free type PILLOBALL Rod Ends

[2] Life calculation

The life of maintenance-free type PILLOBALL Rod Ends is obtained from the total sliding distance S which is given in Fig.6 for the contact pressure p obtained from equation (3).

The total number of oscillations and life in hours can be obtained from the following equations.

$$G = 16.67 \times b_1 \times \frac{Sf}{V} \dots\dots\dots(7)$$

$$L_h = \frac{G}{60f} \dots\dots\dots(8)$$

where, G : Life (Total number of oscillations)
 b_1 : Load directional factor (Refer to Table 9.)
 S : Total sliding distance m
 f : Number of oscillations per minute min⁻¹
 V : Sliding velocity mm/s
 L_h : Life in hours h

Table 9 Load directional factor for maintenance-free type PILLOBALLS b_1

Load direction	Constant	Alternate
Load directional factor b_1	1	0.2 ⁽¹⁾

Note⁽¹⁾ This value is applicable when the load changes comparatively slowly. When the load changes rapidly, please consult IKO, as the factor decreases sharply.

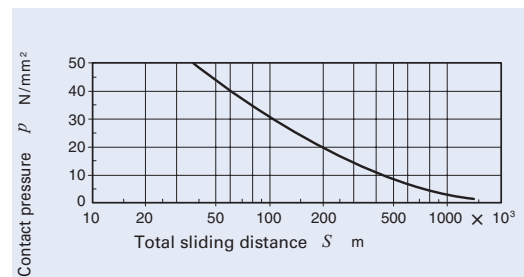


Fig. 6 Contact pressure and total sliding distance for maintenance-free type PILLOBALL Rod Ends

Lubrication

Maintenance-free type PILLOBALL Rod Ends have a sliding surface lined with a self-lubricating lining. Therefore, they can be used without lubrication. Lubrication type PILLOBALLS are not provided with prepacked grease. Perform proper lubrication for use. Operating without lubrication will increase the wear of the sliding contact surfaces and cause seizure.

Oil Hole and Grease Nipple

Table 10 shows the specifications of oil hole and grease nipple on the outer ring or body. Further, lubrication nozzle models compatible with the grease nipple are shown in Table 11.

For PILLOBALLS without an oil hole and grease nipple, apply grease directly on the spherical surface.

Table 10 Specifications of oil hole and grease nipple

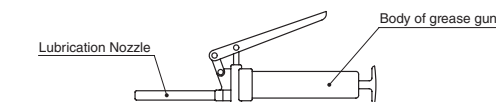
Type	Specification	
	Bore diameter of inner ring d mm	
PB		1 oil hole + oil groove
PHS(…A)	$d \leq 4$	None
	$4 < d$	With grease nipple
POS(…A)	$d \leq 4$	None
	$4 < d \leq 6$	1 oil hole
	$6 < d$	With grease nipple
PHSB · POSB		None ⁽¹⁾
PHSA		With grease nipple
PHS … EC, POS … EC		None

Note⁽¹⁾ Grease Nipple is available for size 4 or larger with supplemental code.

Table 11 Types and Dimension of Lubrication Nozzles

Type	Dimension
A-5126T	
A-5120R	
B-5120R	

Remark HSP-3(Yamada Corporation) can be used for them. The above nozzles can be attached on the standard grease gun shown below.



Operating Temperature Range

The maximum allowable temperature for Lubrication type PILLOBALLS is +180°C for the insert type and +80°C for the die-cast type.

The maximum allowable temperature for Maintenance-free type PILLOBALL Rod Ends is +150°C.

Precautions for Use

1 Tightening depth

The recommended tightening depth of the screw into the PILLOBALL Rod End body is shown below.

Insert type and maintenance-free type: 1.25 times the nominal thread dia. or more.

Die-cast type: 2 times the nominal thread dia. or more.

2 Allowable tilting angle

The allowable tilting angle differs depending on the mounting structure as shown in Table 12 and Table 13.

Table 12 Allowable tilting angle

unit: degree

d Bore diameter mm	PB ⁽¹⁾ , PHS(…A), POS(…A) PHS … EC, POS … EC		PHSA	
	α_1	α_2	α_1	α_2
3	7	13	—	—
4	7	13	—	—
5	8	13	7	13
6	8	13	7	13
8	8	14	8	14
10	8	14	8	14
12	8	13	8	13
14	10	16	9	16
16	9	15	9	15
18	9	15	9	15
20	9	15	9	15
22	10	15	9	15
25	9	15	—	—
28	9	15	—	—
30	10	17	—	—

Note⁽¹⁾ In the case of the PB series, α_2 is applicable in general.

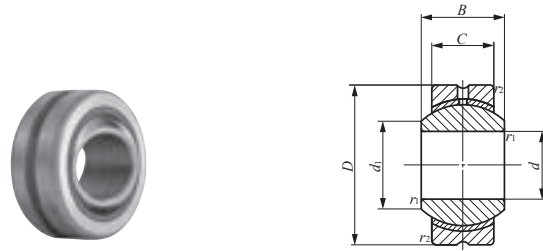
Table 13 Allowable tilting angle for inch series

unit: degree

With female thread	With male thread	α_1	α_2
PHSB 2	POSB 2	8	16
PHSB 2.5	POSB 2.5	7	12
PHSB 3	POSB 3	6	10
PHSB 4	POSB 4	7	13
PHSB 5	POSB 5	6	10
PHSB 6	POSB 6	6	11
PHSB 7	POSB 7	7	11
PHSB 8	POSB 8	6	9
PHSB 10	POSB 10	7	11
PHSB 12	POSB 12	6	10
PHSB 16	POSB 16	7	14

PILLOBALL

Lubrication Type PILLOBALL Spherical Bushings **Insert Type**

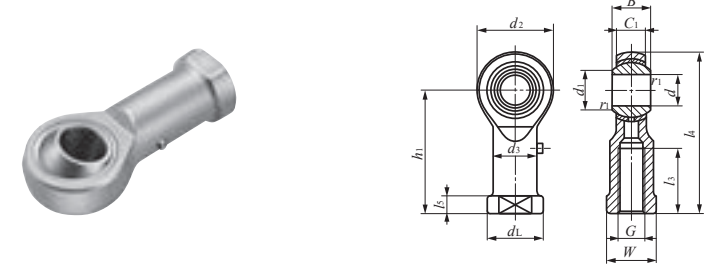


PB

Identification number	Mass (Ref.) g	Boundary dimensions mm							Dynamic load capacity C_d N	Static load capacity C_s N
		d	D	C	B	d_1	$r_{s \min}^{(1)}$	Ball dia. mm (inch)		
PB 5	8.5	5	16	6	8	7.7	0.2	11.112 ($\frac{7}{16}$)	3 270	7 850
PB 6	13	6	18	6.75	9	9	0.2	12.700 ($\frac{1}{2}$)	4 200	10 100
PB 8	24	8	22	9	12	10.4	0.2	15.875 ($\frac{5}{8}$)	7 010	16 800
PB 10	39	10	26	10.5	14	12.9	0.2	19.050 ($\frac{3}{4}$)	9 810	23 500
PB 12	58	12	30	12	16	15.4	0.2	22.225 ($\frac{7}{8}$)	13 100	31 400
PB 14	84	14	34	13.5	19	16.9	0.3	25.400 (1)	16 800	40 400
PB 16	111	16	38	15	21	19.4	0.3	28.575 ($1\frac{1}{8}$)	21 000	50 400
PB 18	160	18	42	16.5	23	21.9	0.3	31.750 ($1\frac{1}{4}$)	25 700	61 600
PB 20	210	20	46	18	25	24.4	0.3	34.925 ($1\frac{3}{8}$)	30 800	74 000
PB 22	265	22	50	20	28	25.8	0.3	38.100 ($1\frac{1}{2}$)	37 400	89 700
PB 25	390	25	56	22	31	29.6	0.6	42.862 ($1\frac{11}{16}$)	46 200	111 000
PB 28	410	28	62	25	35	32.3	0.6	47.625 ($1\frac{7}{8}$)	58 400	140 000
PB 30	610	30	66	25	37	34.8	0.6	50.800 (2)	62 300	149 000

Note⁽¹⁾ Minimum allowable value of chamfer dimensions r_1 and r_2
 Remarks1. The outer ring has an oil groove and an oil hole.
 2. No grease is prepacked. Perform proper lubrication.

Lubrication Type PILLOBALL Rod Ends **Insert Type/With Female Thread**

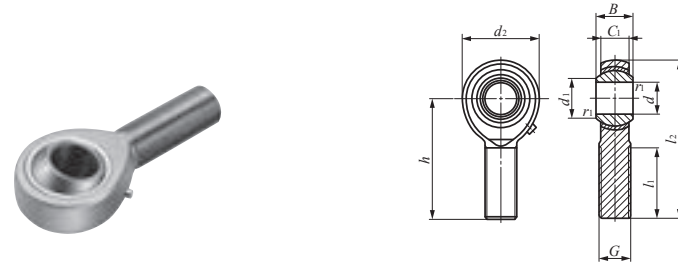


PHS(...A)

Identification number	Mass (Ref.) g	Boundary dimensions mm															Dynamic load capacity C_d N	Static load capacity C_s N
		d	Thread G	d_2	C_1	B	d_1	l_4	h_1	l_3	l_5	W	d_3	d_L	$r_{1smin}^{(1)}$	Ball dia. mm (inch)		
PHS 3	5.7	3	M 3×0.5	12	4.5	6	5.2	27	21	10	3	5.5	5	6.5	0.2	7.938 ($\frac{5}{16}$)	1 750	3 670
PHS 4	11.9	4	M 4×0.7	14	5.3	7	6.5	31	24	12	4	8	8	9.5	0.2	9.525 ($\frac{3}{8}$)	2 480	4 680
PHS 5A	16.5	5	M 5×0.8	16	6	8	7.7	35	27	14	4	9	9	11	0.2	11.112 ($\frac{7}{16}$)	3 270	5 730
PHS 6A	25	6	M 6×1	18	6.75	9	9	39	30	14	5	11	10	13	0.2	12.700 ($\frac{1}{2}$)	4 200	6 910
PHS 8A	43	8	M 8×1.25	22	9	12	10.4	47	36	17	5	14	12.5	16	0.2	15.875 ($\frac{5}{8}$)	7 010	10 200
PHS 10A	72	10	M10×1.5	26	10.5	14	12.9	56	43	21	6.5	17	15	19	0.2	19.050 ($\frac{3}{4}$)	9 810	13 300
PHS 12A	107	12	M12×1.75	30	12	16	15.4	65	50	24	6.5	19	17.5	22	0.2	22.225 ($\frac{7}{8}$)	13 100	16 900
PHS 14A	160	14	M14×2	34	13.5	19	16.9	74	57	27	8	22	20	25	0.2	25.400 (1)	16 800	20 900
PHS 16A	210	16	M16×2	38	15	21	19.4	83	64	33	8	22	22	27	0.2	28.575 ($1\frac{1}{8}$)	21 000	25 400
PHS 18A	295	18	M18×1.5	42	16.5	23	21.9	92	71	36	10	27	25	31	0.2	31.750 ($1\frac{1}{4}$)	25 700	30 200
PHS 20	380	20	M20×1.5	46	18	25	24.4	100	77	40	10	30	27.5	34	0.2	34.925 ($1\frac{3}{8}$)	30 800	35 500
PHS 22	490	22	M22×1.5	50	20	28	25.8	109	84	43	12	32	30	37	0.2	38.100 ($1\frac{1}{2}$)	37 400	41 700
PHS 25	750	25	M24×2	60	22	31	29.6	124	94	48	12	36	33.5	42	0.6	42.862 ($1\frac{11}{16}$)	46 200	72 700
PHS 28	950	28	M27×2	66	25	35	32.3	136	103	53	12	41	37	46	0.6	47.625 ($1\frac{7}{8}$)	58 400	87 000
PHS 30	1 130	30	M30×2	70	25	37	34.8	145	110	56	15	41	40	50	0.6	50.800 (2)	62 300	92 200

Note⁽¹⁾ Minimum allowable value of chamfer dimension r_1
 Remarks1. Neither oil hole nor grease nipple is provided for PHS with an inner ring bore diameter d of 4 mm or less.
 For others, a grease nipple is provided on the body.
 2. No grease is prepacked. Perform proper lubrication.
 3. When a metric fine thread specification for inner ring bore diameter d of 8 mm to 14 mm is required, please contact IKO.

Lubrication Type PILLOBALL Rod Ends **Insert Type/With Male Thread**

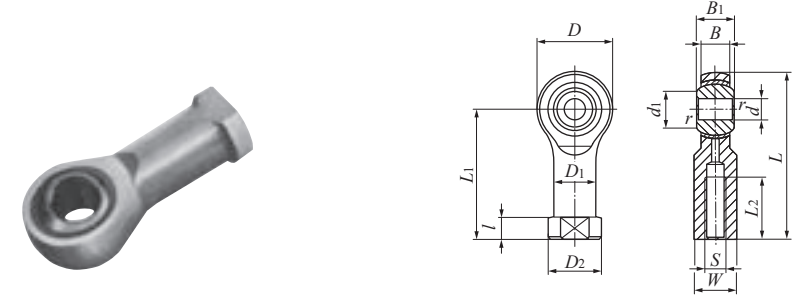


POS(...A)

Identification number	Mass (Ref.) g	Boundary dimensions mm											Dynamic load capacity C_d N	Static load capacity C_s N
		d	Thread G	d_2	C_1	B	d_1	l_2	h	l_1	$r_{1smin}^{(1)}$	Ball dia. mm (inch)		
POS 3	5.0	3	M 3×0.5	12	4.5	6	5.2	33	27	15	0.2	7.938 ($\frac{5}{16}$)	1 750	1 220
POS 4	8.1	4	M 4×0.7	14	5.3	7	6.5	37	30	17	0.2	9.525 ($\frac{3}{8}$)	2 480	2 060
POS 5A	12.5	5	M 5×0.8	16	6	8	7.7	41	33	20	0.2	11.112 ($\frac{7}{16}$)	3 270	3 340
POS 6A	19	6	M 6×1	18	6.75	9	9	45	36	22	0.2	12.700 ($\frac{1}{2}$)	4 200	4 730
POS 8A	32	8	M 8×1.25	22	9	12	10.4	53	42	25	0.2	15.875 ($\frac{5}{8}$)	7 010	8 640
POS 10A	54	10	M10×1.5	26	10.5	14	12.9	61	48	29	0.2	19.050 ($\frac{3}{4}$)	9 810	13 300
POS 12A	85	12	M12×1.75	30	12	16	15.4	69	54	33	0.2	22.225 ($\frac{7}{8}$)	13 100	16 900
POS 14A	126	14	M14×2	34	13.5	19	16.9	77	60	36	0.2	25.400 (1)	16 800	20 900
POS 16A	185	16	M16×2	38	15	21	19.4	85	66	40	0.2	28.575 ($1\frac{1}{8}$)	21 000	25 400
POS 18A	260	18	M18×1.5	42	16.5	23	21.9	93	72	44	0.2	31.750 ($1\frac{1}{4}$)	25 700	30 200
POS 20	340	20	M20×1.5	46	18	25	24.4	101	78	47	0.2	34.925 ($1\frac{3}{8}$)	30 800	35 500
POS 22	435	22	M22×1.5	50	20	28	25.8	109	84	51	0.2	38.100 ($1\frac{1}{2}$)	37 400	41 700
POS 25	650	25	M24×2	60	22	31	29.6	124	94	57	0.6	42.862 ($1\frac{11}{16}$)	46 200	72 700
POS 28	875	28	M27×2	66	25	35	32.3	136	103	62	0.6	47.625 ($1\frac{7}{8}$)	58 400	87 000
POS 30	1 070	30	M30×2	70	25	37	34.8	145	110	66	0.6	50.800 (2)	62 300	92 200

Note⁽¹⁾ Minimum allowable value of chamfer dimension r_1
 Remarks1. Neither oil hole nor grease nipple is provided for POS with an inner ring bore diameter d of 4 mm or less.
 For those with an inner ring bore diameter d of 5 to 6 mm, an oil hole is provided on the body. For others, a grease nipple is provided on the body.
 2. No grease is prepacked. Perform proper lubrication.
 3. When a metric fine thread specification for inner ring bore diameter d of 8 mm to 14 mm is required, please contact IKO.

Inch series PILLOBALL Rod Ends **Insert Type/With Female Thread**

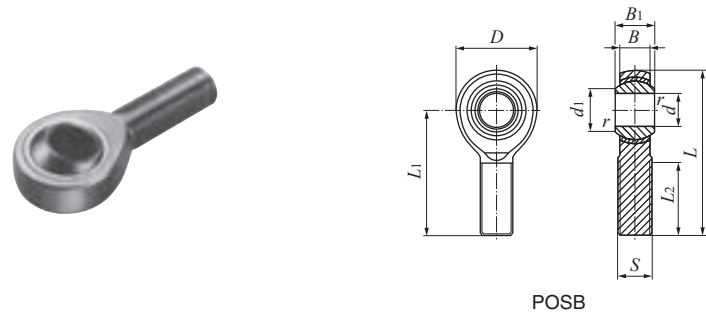


PHSB

Identification number	Mass (Ref.) g	Boundary dimensions mm(inch)															Dynamic load capacity C_d N	Static load capacity C_s N
		d	Thread S class 3B	D	B	B_1	d_1	L	l	L_1	L_2	W	D_1	D_2	$r_{smin}^{(1)}$	Ball dia. mm (inch)		
PHSB 2	6.8	3.175 (.1250)	-32UNC (.1380)	11.91 (.469)	4.75 (.187)	6.35 (.250)	4.75 (.187)	26.57 (1.046)	4.75 (.187)	20.62 (.812)	9.53 (.375)	6.35 (.250)	6.35 (.250)	7.92 (.312)	0.3 (.012)	7.938 ($\frac{5}{16}$)	1 850	5 840
PHSB 2.5	11	3.967 (.1562)	-32UNC (.1640)	14.27 (.562)	5.56 (.219)	7.14 (.281)	6.32 (.249)	29.36 (1.156)	4.75 (.187)	22.23 (.875)	9.53 (.375)	7.14 (.281)	7.14 (.281)	8.74 (.344)	0.3 (.012)	9.525 ($\frac{3}{8}$)	2 600	8 210
PHSB 3	14	4.826 (.1900)	-32UNF (.1900)	15.88 (.625)	6.35 (.250)	7.92 (.312)	7.77 (.306)	34.93 (1.375)	4.75 (.187)	26.97 (1.062)	14.27 (.562)	7.92 (.312)	7.92 (.312)	10.31 (.406)	0.3 (.012)	11.112 ($\frac{7}{16}$)	3 460	9 090
PHSB 4	23	6.350 (.2500)	-28UNF (.2500)	19.05 (.750)	7.14 (.281)	9.53 (.375)	9.02 (.355)	42.85 (1.687)	4.75 (.187)	33.32 (1.312)	19.05 (.750)	9.53 (.375)	9.53 (.375)	11.89 (.468)	0.5 (.020)	13.097 ($\frac{33}{64}$)	4 590	13 200
PHSB 5	36	7.938 (.3125)	-24UNF (.3125)	22.23 (.875)	8.74 (.344)	11.10 (.437)	11.35 (.447)	46.02 (1.812)	4.75 (.187)	34.93 (1.375)	19.05 (.750)	11.10 (.437)	11.10 (.437)	12.70 (.500)	0.5 (.020)	15.875 ($\frac{5}{8}$)	6 800	16 500
PHSB 6	59	9.525 (.3750)	-24UNF (.3750)	25.40 (1.000)	10.31 (.406)	12.70 (.500)	13.13 (.517)	53.98 (2.125)	6.35 (.250)	41.28 (1.625)	23.80 (.937)	14.27 (.562)	14.27 (.562)	17.45 (.687)	0.5 (.020)	18.256 ($\frac{23}{32}$)	9 230	21 600
PHSB 7	82	11.112 (.4375)	-20UNF (.4375)	28.58 (1.125)	11.10 (.437)	14.27 (.562)	14.88 (.586)	60.33 (2.375)	6.35 (.250)	46.02 (1.812)	26.97 (1.062)	15.88 (.625)	15.88 (.625)	19.05 (.750)	0.5 (.020)	20.638 ($\frac{13}{16}$)	11 200	26 100
PHSB 8	132	12.700 (.5000)	-20UNF (.5000)	33.32 (1.312)	12.70 (.500)	15.88 (.625)	17.73 (.698)	70.64 (2.781)	6.35 (.250)	53.98 (2.125)	30.15 (1.187)	19.05 (.750)	19.05 (.750)	22.23 (.875)	0.5 (.020)	23.812 ($\frac{15}{16}$)	14 800	36 200
PHSB 10	191	15.875 (.6250)	-18UNF (.6250)	38.10 (1.500)	14.27 (.562)	19.05 (.750)	21.31 (.839)	82.55 (3.250)	7.92 (.312)	63.50 (2.500)	38.10 (1.500)	22.23 (.875)	22.23 (.875)	25.40 (1.000)	0.5 (.020)	28.575 ($1\frac{1}{8}$)	20 000	39 300
PHSB 12	286	19.050 (.7500)	-16UNF (.7500)	44.45 (1.750)	17.45 (.687)	22.23 (.875)	24.84 (.978)	95.25 (3.750)	7.92 (.312)	73.03 (2.875)	44.45 (1.750)	25.40 (1.000)	25.40 (1.000)	28.58 (1.125)	0.5 (.020)	33.338 ($1\frac{3}{16}$)	28 500	55 000
PHSB 16	998	25.400 (1.0000)	-12UNF (1.2500)	69.85 (2.750)	25.40 (1.000)	34.93 (1.375)	32.23 (1.269)	139.70 (5.500)	11.07 (.436)	104.78 (4.125)	53.98 (2.125)	38.10 (1.500)	38.10 (1.500)	44.45 (1.750)	0.5 (.020)	47.625 ($1\frac{7}{8}$)	59 300	86 800

Note⁽¹⁾ r_s min stands for minimum allowable value of chamfer r .
 Remark No grease is prepacked. Perform proper lubrication.

Inch series PILLOBALL Rod Ends **Insert Type/With Male Thread**

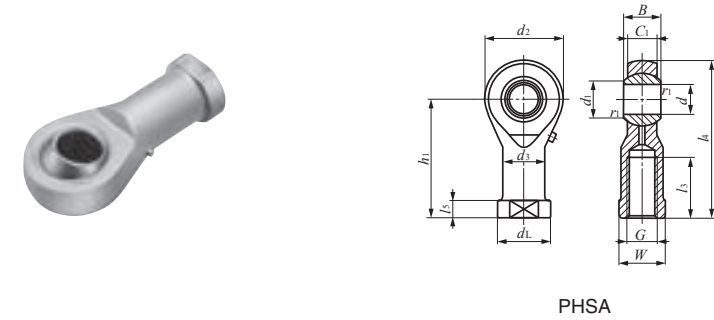


POSB

Identification number	Mass (Ref.) g	Boundary dimensions mm(inch)											Dynamic load capacity C_d N	Static load capacity C_s N
		d	Thread S class 3A	D	B	B_1	d_1	L	L_1	L_2	$r_{s\min}^{(1)}$	Ball dia. mm (inch)		
POSB 2	5.4	3.175 (.1250)	-32UNC (.1380)	11.91 (.469)	4.75 (.187)	6.35 (.250)	4.75 (.187)	29.77 (1.172)	23.80 (.937)	12.70 (.500)	0.3 (.012)	7.938 ($\frac{5}{16}$)	1 850	2 160
POSB 2.5	9.1	3.967 (.1562)	-32UNC (.1640)	14.27 (.562)	5.56 (.219)	7.14 (.281)	6.32 (.249)	35.71 (1.406)	28.58 (1.125)	15.88 (.625)	0.3 (.012)	9.525 ($\frac{3}{8}$)	2 600	3 370
POSB 3	14	4.826 (.1900)	-32UNF (.1900)	15.88 (.625)	6.35 (.250)	7.92 (.312)	7.77 (.306)	39.70 (1.563)	31.75 (1.250)	19.05 (.750)	0.3 (.012)	11.112 ($\frac{7}{16}$)	3 460	4 850
POSB 4	23	6.350 (.2500)	-28UNF (.2500)	19.05 (.750)	7.14 (.281)	9.53 (.375)	9.02 (.355)	49.20 (1.937)	39.67 (1.562)	25.40 (1.000)	0.5 (.020)	13.097 ($\frac{33}{64}$)	4 590	8 870
POSB 5	36	7.938 (.3125)	-24UNF (.3125)	22.23 (.875)	8.74 (.344)	11.10 (.437)	11.35 (.447)	58.72 (2.312)	47.63 (1.875)	31.75 (1.250)	0.5 (.020)	15.875 ($\frac{5}{8}$)	6 800	14 200
POSB 6	54	9.525 (.3750)	-24UNF (.3750)	25.40 (1.000)	10.31 (.406)	12.70 (.500)	13.13 (.517)	61.93 (2.438)	49.23 (1.938)	31.75 (1.250)	0.5 (.020)	18.256 ($\frac{23}{32}$)	9 230	21 600
POSB 7	77	11.112 (.4375)	-20UNF (.4375)	28.58 (1.125)	11.10 (.437)	14.27 (.562)	14.88 (.586)	68.28 (2.688)	53.98 (2.125)	34.93 (1.375)	0.5 (.020)	20.638 ($\frac{13}{16}$)	11 200	26 100
POSB 8	122	12.700 (.5000)	-20UNF (.5000)	33.32 (1.312)	12.70 (.500)	15.88 (.625)	17.73 (.698)	78.59 (3.094)	61.93 (2.438)	38.10 (1.500)	0.5 (.020)	23.812 ($\frac{15}{16}$)	14 800	36 200
POSB 10	186	15.875 (.6250)	-18UNF (.6250)	38.10 (1.500)	14.27 (.562)	19.05 (.750)	21.31 (.839)	85.73 (3.375)	66.68 (2.625)	41.28 (1.625)	0.5 (.020)	28.575 ($1\frac{1}{8}$)	20 000	39 300
POSB 12	295	19.050 (.7500)	-16UNF (.7500)	44.45 (1.750)	17.45 (.687)	22.23 (.875)	24.84 (.978)	95.25 (3.750)	73.03 (2.875)	44.45 (1.750)	0.5 (.020)	33.338 ($1\frac{3}{16}$)	28 500	55 000
POSB 16	1 129	25.400 (1.0000)	-12UNF (1.2500)	69.85 (2.750)	25.40 (1.000)	34.93 (1.375)	32.23 (1.269)	139.70 (5.500)	104.78 (4.125)	53.98 (2.125)	0.5 (.020)	47.625 ($1\frac{7}{8}$)	59 300	112 000

Note⁽¹⁾ r_s min stands for minimum allowable value of chamfer r .
Remark No grease is prepacked. Perform proper lubrication.

Lubrication Type PILLOBALL Rod Ends **Die-cast Type/With Female Thread**

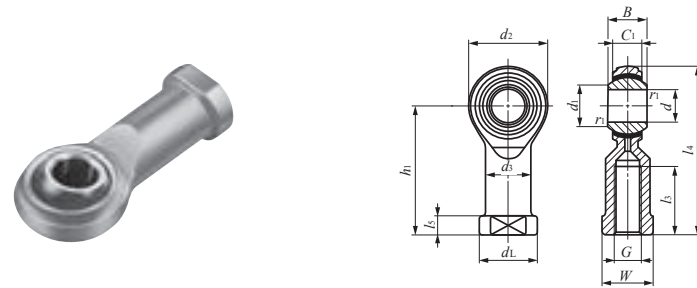


PHSA

Identification number	Mass (Ref.) g	Boundary dimensions mm																Static load capacity C_s N
		d	Thread G	d_2	C_1	B	d_1	l_4	h_1	l_3	l_5	W	d_3	d_L	$r_{1s\min}^{(1)}$	Ball dia. mm (inch)		
PHSA 5	17	5	M 5×0.8	17	6	8	7.7	35.5	27	16	4	9	9	11	0.2	11.112 ($\frac{7}{16}$)	5 470	
PHSA 6	25	6	M 6×1	19.5	6.75	9	9	39.7	30	16	5	11	10	13	0.2	12.700 ($\frac{1}{2}$)	6 760	
PHSA 8	45	8	M 8×1.25	24	9	12	10.4	48	36	19	5	14	12.5	16	0.2	15.875 ($\frac{5}{8}$)	10 200	
PHSA 10	70	10	M10×1.5	28	10.5	14	12.9	57	43	23	6.5	17	15	19	0.2	19.050 ($\frac{3}{4}$)	13 100	
PHSA 12	105	12	M12×1.75	32	12	16	15.4	66	50	27	6.5	19	17.5	22	0.2	22.225 ($\frac{7}{8}$)	16 400	
PHSA 14	155	14	M14×2	36	13.5	19	16.9	75	57	30	8	22	20	25	0.3	25.400 (1)	20 000	
PHSA 16	190	16	M16×2	40	15	21	19.4	84	64	36	8	22	22	27	0.3	28.575 ($1\frac{1}{8}$)	23 900	
PHSA 18	290	18	M18×1.5	45	16.5	23	21.9	93.5	71	40	10	27	25	31	0.3	31.750 ($1\frac{1}{4}$)	28 800	
PHSA 20	400	20	M20×1.5	49	18	25	24.4	101.5	77	43	10	30	27.5	34	0.3	34.925 ($1\frac{3}{8}$)	33 400	
PHSA 22	500	22	M22×1.5	54	20	28	25.8	111	84	47	12	32	30	37	0.3	38.100 ($1\frac{1}{2}$)	40 400	

Note⁽¹⁾ Minimum allowable value of chamfer dimension r_1 .
Remarks1. A grease nipple is provided on the body.
2. No grease is prepacked. Perform proper lubrication.
3. When a metric fine thread specification for inner ring bore deameter d of 8 mm to 14 mm is required, please contact IKO.

Maintenance-free Type PILLOBALL Rod Ends **With Female Thread**



PHS...EC

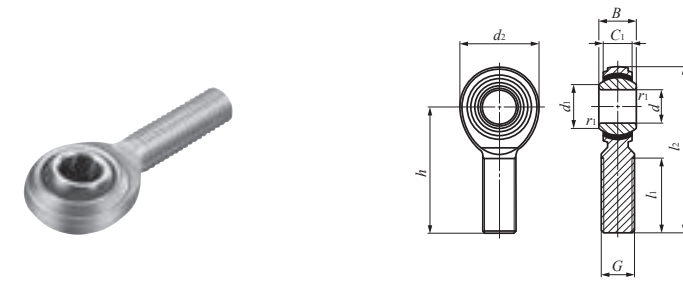
Identification number	Mass (Ref.) g	Boundary dimensions mm														Dynamic load capacity C_d N	Static load capacity C_s N	
		d	Thread G	d_2	C_1	B	d_1	l_4	h_1	l_3	l_5	W	d_3	d_L	$r_{1smin}^{(1)}$			Ball dia. mm (inch)
PHS 3EC	5.7	3	M 3×0.5	12	4.5	6	5.2	27	21	10	3	5.5	5	6.5	0.2	7.938 ($\frac{5}{16}$)	3 500	2 480
PHS 4EC	11.9	4	M 4×0.7	14	5.3	7	6.5	31	24	12	4	8	8	9.5	0.2	9.525 ($\frac{3}{8}$)	4 950	3 260
PHS 5EC	16.5	5	M 5×0.8	16	6	8	7.7	35	27	12.5	4	9	9	11	0.2	11.112 ($\frac{7}{16}$)	6 540	4 010
PHS 6EC	25	6	M 6×1	18	6.75	9	9	39	30	13.5	5	11	10	13	0.2	12.700 ($\frac{1}{2}$)	8 410	4 940
PHS 8EC	43	8	M 8×1.25	22	9	12	10.4	47	36	16	5	14	12.5	16	0.2	15.875 ($\frac{5}{8}$)	14 000	7 760
PHS 10EC	72	10	M10×1.5	26	10.5	14	12.9	56	43	19.5	6.5	17	15	19	0.2	19.050 ($\frac{3}{4}$)	19 600	10 500
PHS 12EC	107	12	M12×1.75	30	12	16	15.4	65	50	24	6.5	19	17.5	22	0.2	22.225 ($\frac{7}{8}$)	26 200	13 700
PHS 14EC	160	14	M14×2	34	13.5	19	16.9	74	57	27	8	22	20	25	0.2	25.400 (1)	33 600	17 200
PHS 16EC	210	16	M16×2	38	15	21	19.4	83	64	33	8	22	22	27	0.2	28.575 ($1\frac{1}{8}$)	42 000	21 100
PHS 18EC	295	18	M18×1.5	42	16.5	23	21.9	92	71	36	10	27	25	31	0.2	31.750 ($1\frac{1}{4}$)	51 400	25 100
PHS 20EC	380	20	M20×1.5	46	18	25	24.4	100	77	40	10	30	27.5	34	0.2	34.925 ($1\frac{3}{8}$)	61 600	30 000
PHS 22EC	490	22	M22×1.5	50	20	28	25.8	109	84	41	12	32	30	37	0.2	38.100 ($1\frac{1}{2}$)	74 700	36 400

Note⁽¹⁾ Minimum allowable value of chamfer dimension r_1

Remarks1. Neither oil hole nor grease nipple is provided.

2. When a metric fine thread specification for inner ring bore deameter d of 8 mm to 14 mm is required, please contact IKO.

Maintenance-free Type PILLOBALL Rod Ends **With Male Thread**



POS...EC

Identification number	Mass (Ref.) g	Boundary dimensions mm														Dynamic load capacity C_d N	Static load capacity C_s N
		d	Thread G	d_2	C_1	B	d_1	l_2	h	l_1	$r_{1smin}^{(1)}$	Ball dia. mm (inch)					
POS 3EC	5.0	3	M 3×0.5	12	4.5	6	5.2	33	27	15	0.2	7.938 ($\frac{5}{16}$)	3 500	1 220			
POS 4EC	8.1	4	M 4×0.7	14	5.3	7	6.5	37	30	17	0.2	9.525 ($\frac{3}{8}$)	4 950	2 060			
POS 5EC	12.5	5	M 5×0.8	16	6	8	7.7	41	33	20	0.2	11.112 ($\frac{7}{16}$)	6 540	3 340			
POS 6EC	19	6	M 6×1	18	6.75	9	9	45	36	22	0.2	12.700 ($\frac{1}{2}$)	8 410	4 730			
POS 8EC	32	8	M 8×1.25	22	9	12	10.4	53	42	25	0.2	15.875 ($\frac{5}{8}$)	14 000	7 760			
POS 10EC	54	10	M10×1.5	26	10.5	14	12.9	61	48	29	0.2	19.050 ($\frac{3}{4}$)	19 600	10 500			
POS 12EC	85	12	M12×1.75	30	12	16	15.4	69	54	33	0.2	22.225 ($\frac{7}{8}$)	26 200	13 700			
POS 14EC	126	14	M14×2	34	13.5	19	16.9	77	60	36	0.2	25.400 (1)	33 600	17 200			
POS 16EC	185	16	M16×2	38	15	21	19.4	85	66	40	0.2	28.575 ($1\frac{1}{8}$)	42 000	21 100			
POS 18EC	260	18	M18×1.5	42	16.5	23	21.9	93	72	44	0.2	31.750 ($1\frac{1}{4}$)	51 400	25 100			
POS 20EC	340	20	M20×1.5	46	18	25	24.4	101	78	47	0.2	34.925 ($1\frac{3}{8}$)	61 600	30 000			
POS 22EC	435	22	M22×1.5	50	20	28	25.8	109	84	51	0.2	38.100 ($1\frac{1}{2}$)	74 700	36 400			

Note⁽¹⁾ Minimum allowable value of chamfer dimension r_1

Remarks1. Neither oil hole nor grease nipple is provided.

2. When a metric fine thread specification for inner ring bore deameter d of 8 mm to 14 mm is required, please contact IKO.

L-BALLS

- L-Balls
- L-Ball Dust Cover



Structure and Features

IKO L-Balls are self-aligning rod-ends consisting of a special zinc die-cast alloy body and a studded ball which has its axis at right angles to the body. They can perform tilting movement, oscillating movement and rotation with low torque, and transmit power smoothly due to uniform clearance between the sliding surfaces. Their superior wear resistance assures stable accuracy for long periods of time, and maintenance is simple. They are very economical bearings. For these reasons, they are widely used in link mechanisms in automobiles, construction machinery, farm and packaging machines, etc.

Types

L-Balls are available in various types as shown in Table 1.

Table 1 Type of L-Balls

Type	L-Ball		L-Ball dust cover
	LHSA	LHS	PRC
Model code	LHSA	LHS	PRC

L-Ball LHSA

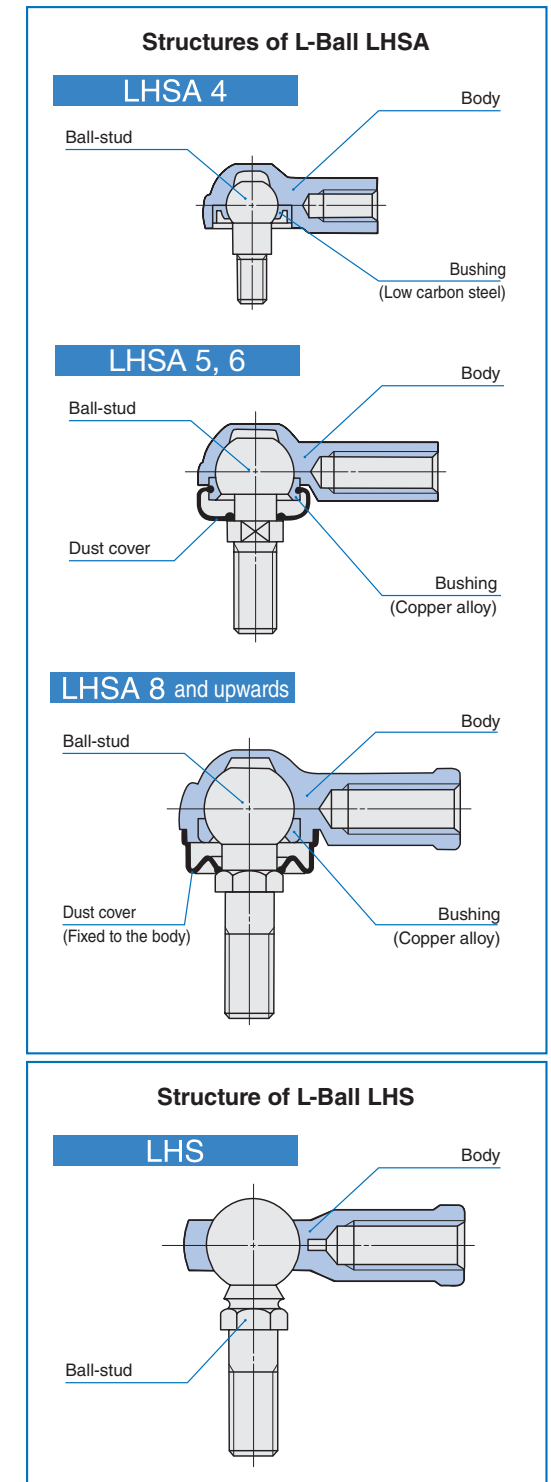
These are compact rod-ends in which the spherical part of the ball-stud are held by the special zinc die-cast alloy body. There is a dust cover on the stud side and good quality lithium soap base grease is pre-packed. They can be run for long periods of time without re-lubrication and have excellent lubrication and anti-dust properties.

As shown in the structural drawing, these rod-ends are classified into 3 types by size. In addition, the ball-studs of LHSA 10 and lower are formed in one solid body, but those of LHSA 12 and higher, which are used under large loads, have the stud friction-welded to a high precision steel ball to give greater resistance to wear.

L-Ball LHS

These rod-ends have a friction-welded ball-stud, and a special zinc die-cast alloy body which houses the spherical surface of the high precision steel ball. There is an almost complete contact across the sliding surfaces, and the uniform clearance guarantees a stable bearing life.

An L-Ball dust cover can be attached to these rod-ends. If the rod-ends are lubricated with lithium soap



base grease, they have excellent lubrication and anti-dust properties and can run for long periods of time without re-lubrication. When the L-Ball LHS is delivered with a dust cover on request, lithium soap base grease is prepacked.

L-Ball Dust Cover PRC

This is for the L-Ball LHS series. It is made of special synthetic rubber which has excellent resistance to oil and ozone. The cover offers very effective dust protection and prevents grease leakage.

Identification Number

The identification number of L-Balls consists of a model code, a size and any supplemental codes as shown in the examples.

Examples of identification number

Example 1 (Female thread of the body : In case of right-hand threaded)

Model code: LHS, Size: 8

Type: LHS, Size of thread (M8): 8

Example 2 (Female thread of the body : In case of left threaded)

Model code: LHS, Size: 8, Supplemental code: L

Left-handed thread: L

Example 3 (when a dust cover PRC is attached to LHS)

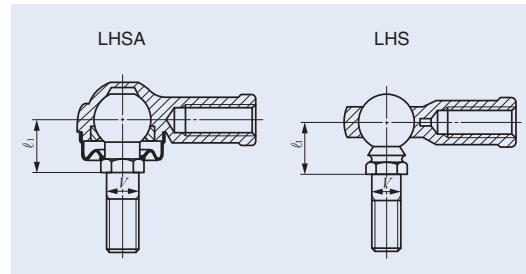
Model code: LHS, Size: 8, Supplemental code: D

With dust cover: D

Accuracy

The accuracy of L-Balls is shown in Table 2.

Table 2 Tolerance



Type	Dimension symbol	Tolerance
LHSA	l_1	± 0.5
	V	0 - 0.2 ⁽¹⁾
LHS	l_1	± 0.4
	V	h9

unit: mm

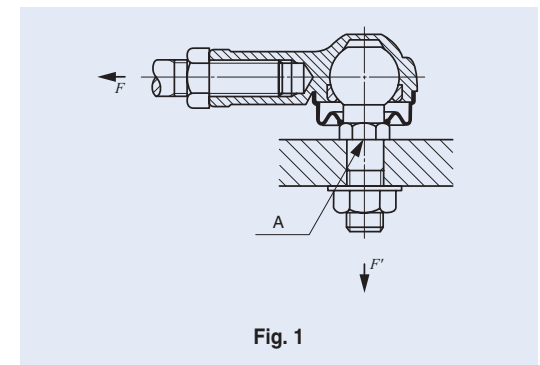
Note⁽¹⁾ This dimensional tolerance applies to LHSA 5 and higher.

Selection of L-Balls

The static load capacity and maximum operating load of L-Balls are determined in consideration of the strength of the ball stud and the body. Accordingly, L-Balls are selected on the basis of the static load capacity C_s shown in the dimension table and the maximum operating load shown in Table 3.

Static load capacity

The static load capacity C_s shown in the dimension table represents the allowable axial force F which is determined by the mechanical strength of the ball-stud at the section 'A' under the bending moment due to the force F as illustrated in Fig. 1. If F increases beyond the static load capacity, deformation will begin at A, leading to breakage.



Maximum operating load

The strength of the body must also be taken into consideration when L-Balls are operated in a high-temperature or low-temperature atmosphere or receive repetitive loads of long duration or shock loads. A guideline for maximum operating load of L-Balls is shown in Table 3. When the fixing bolt in the main body is fixed and a load is applied in the direction of F' , the bending stress in the fixing bolt must be taken into consideration.

Table 3 Maximum operating load unit: N

Identification number	Maximum operating load	Identification number	Maximum operating load
LHSA 4	840	LHS 5	880
LHSA 5	1 180	LHS 6	1 080
LHSA 6	1 080	LHS 8	1 630
LHSA 8	1 900	LHS10	2 100
LHSA10	2 170	LHS12	2 620
LHSA10M	2 170	LHS14	3 190
LHSA12	2 790	LHS16	3 820
LHSA14	3 540	LHS18	4 610
—	—	LHS20	5 340
—	—	LHS22	6 460

Lubrication

LHSA is prepacked with lubricating grease ALVANIA GREASE S2 (Shell Lubricants Japan K.K.). LHS is not provided with prepacked grease. Perform proper lubrication.

Operating LHS without lubrication will increase the wear of the sliding contact surface or cause seizure.

Operating Temperature Range

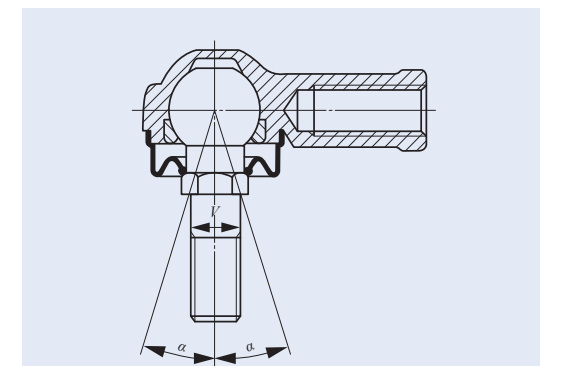
The maximum allowable temperature for L-Balls is +80°C.

Precautions for Use

1 Tightening depth
It is recommended that the tightening depth of the screw into the body is more than twice the nominal diameter of thread.

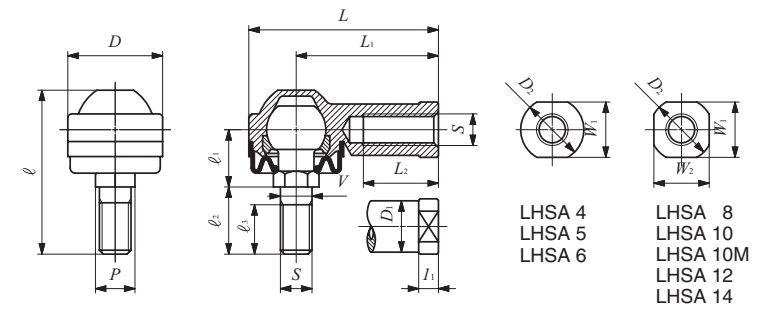
2 Allowable tilting angle
The allowable tilting angle is shown in Table 4.

Table 4 Allowable tilting angle



Nominal dia. mm	LHSA	LHS
V	α	α
4	15	—
5	17	15
6	17	17
8	18	18
10	19	19
12	19	19
14	20	20
16	—	20
18	—	21
20	—	20
22	—	21

unit: degree



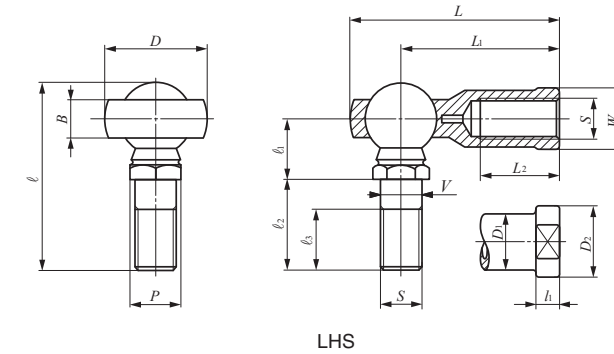
LHSA 4
LHSA 5
LHSA 6

LHSA 8
LHSA 10
LHSA 10M
LHSA 12
LHSA 14

Identification number	Mass (Ref.) g	Boundary dimensions mm												
		Thread S	V	D	L	L ₁	L ₂	l ₁	W ₁	W ₂	D ₁	D ₂	ℓ	P
LHSA 4	11	M 4×0.7	*4	14	25	18	8	4	8	—	8	10	19.5	*5.5
LHSA 5	27	M 5×0.8	5	17	38.5	30	16	5	10	—	10	12	32.5	8
LHSA 6	27	M 6×1	6	19	39.5	30	16	5	10	—	10	12	32.5	8
LHSA 8	64	M 8×1.25	8	24	48	36	19	5	14	14	13	16	41.5	10
LHSA 10	106	M10×1.25	10	28	57	43	23	6.5	17	17	15	19	49	12
LHSA 10M	106	M10×1.5	10	28	57	43	23	6.5	17	17	15	19	49	12
LHSA 12	180	M12×1.75	12	34	67	50	27	6.5	19	19	17.5	22	64	14
LHSA 14	260	M14×2	14	38	76	57	30	8	22	22	20	25	72	17

Remarks1. The item marked * is manufactured with a neck diameter of $\phi 3.4$. The item marked * is manufactured with a diameter of $\phi 5.5$ instead of a width across flats.
2. Provided with prepacked grease.

l ₁	l ₂	l ₃	Ball dia.	Static load capacity
				C _s N
7	7	5	8	880
12	13	10	11.112	1 180
12	13	10	11.112	1 670
14.5	17	12.5	15	4 380
16	21	17	19.05	7 400
16	21	17	19.05	7 400
20	30	20	22.225	9 900
22.5	33.5	22	25.4	14 600



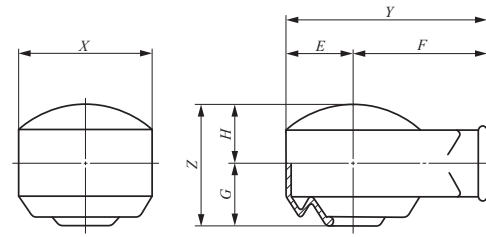
Identification number	Mass (Ref.) g	Thread S	Boundary dimensions mm											
			V	D	B	L	L ₁	L ₂	l ₁	W	D ₁	D ₂	l	P
LHS 5	22	M 5×0.8	5	17	6	35.5	27	16	4	9	9	11	30.5	8
LHS 6	32	M 6×1	6	19.5	6.75	39.7	30	16	5	11	10	13	36.5	10
LHS 8	60	M 8×1.25	8	24	9	48	36	19	5	14	12.5	16	44	11
LHS 10	102	M10×1.5	10	28	10.5	57	43	23	6.5	17	15	19	52.5	13
LHS 12	160	M12×1.75	12	32	12	66	50	27	6.5	19	17.5	22	61	17
LHS 14	227	M14×2	14	36	13.5	75	57	30	8	22	20	25	69	17
LHS 16	300	M16×2	16	40	15	84	64	36	8	22	22	27	74	19
LHS 18	445	M18×1.5	18	45	16.5	93.5	71	40	10	27	25	31	84	22
LHS 20	580	M20×1.5	20	49	18	101.5	77	43	10	30	27.5	34	90.5	24
LHS 22	765	M22×1.5	22	54	20	111	84	47	12	32	30	37	99	27

Remark No grease is prepacked. Perform proper lubrication.

l ₁	l ₂	l ₃	Ball dia.	Static load capacity	
				C _s	N
10	15	11	11.112	2 080	
11.5	18.5	14	12.7	3 290	
14.5	21.5	15	15.875	4 900	
17	26	18	19.05	7 640	
20	30	20	22.225	12 400	
22.5	33.5	22	25.4	14 600	
24.5	35.5	23	28.575	19 500	
27.5	40.5	25	31.75	25 600	
30	43	27	34.925	31 600	
32.5	47.5	30	38.1	39 800	

L-BALL

L-Ball Dust Cover



PRC

Identification number	Boundary dimensions mm						
	<i>X</i>	<i>Y</i>	<i>E</i>	<i>F</i>	<i>Z</i>	<i>G</i>	<i>H</i>
PRC 5	20	29	10	19	16	8	8
PRC 6	22	31	11	20	19	9.5	9.5
PRC 8	27	38.5	13.5	25	24	12	12
PRC 10	31	45.5	15.5	30	27	14	13
PRC 12	36	53	18	35	32	16.5	15.5
PRC 14	40	60	20	40	36.5	19	17.5
PRC 16	44	68	22	46	40	20.5	19.5
PRC 18	49	74.5	24.5	50	46	23.5	22.5
PRC 20	54	82	27	55	50	25.5	24.5
PRC 22	59	89.5	29.5	60	53.5	27.5	26



K

LHSA
LHS

SUPER FLEXIBLE NOZZLES



Structure and Features

IKO Super Flexible Nozzle is a compact nozzle for use on a machine tool to supply and spray cutting oil exactly at the required positions.

The angle of the nozzle can be changed easily and freely. Therefore, oil supply can be concentrated upon the working area, and cooling and lubrication can be performed effectively. As a result, cutting resistance is reduced and superior finish is obtained, achieving high machining accuracy. Also, tool life is longer.

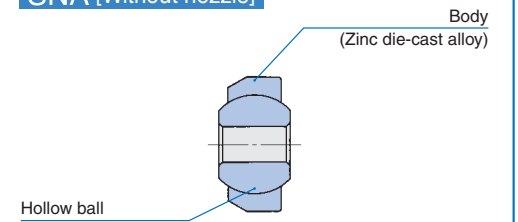
The Super Flexible Nozzle is used in many places such as at the spindle end of Machining Center and at the tool holder of N/C lathe.

The features of Super Flexible Nozzle are as follows.

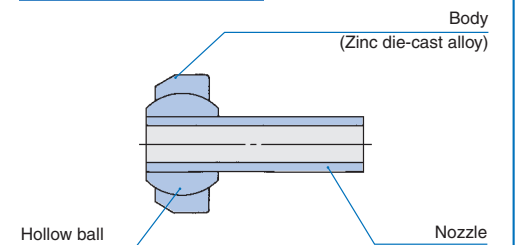
- ① A spherical bushing is incorporated to adjust the tilting angle of nozzle easily.
- ② The Super Flexible Nozzle is compact in size, and the design on parts around the spindle and tool can be made simple.
- ③ The nozzle length is short, and winding of cutting chips around the nozzle will not occur.
- ④ By using a number of Super Flexible Nozzles, cutting oil can be supplied and cutting chips can be removed more effectively.
- ⑤ The press fitting type and screw fitting type are available. The press fitting type is economical.

Structures of Super Flexible Nozzles

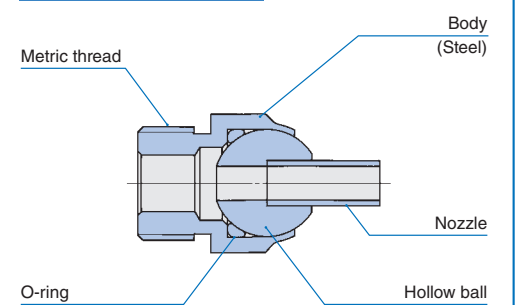
SNA [Without nozzle]



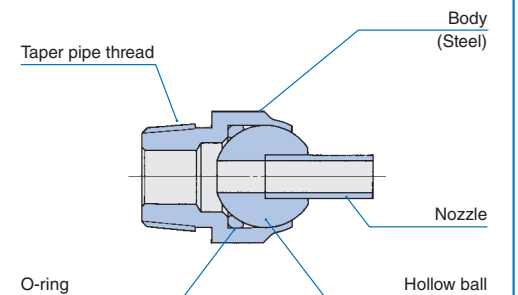
SNA [With nozzle]



SNM



SNPT



Types

Super Flexible Nozzles shown in Table 1 are available.

Table 1 Type of Super Flexible Nozzle

Type		Model code
Press fitting type	Without nozzle	SNA
	With nozzle	
Screw fitting type	With metric threads	SNM
	With taper pipe threads	SNPT

Identification Number

The identification number of Super Flexible Nozzle consists of a model code and a size. An example is shown as follows.

Example of identification number

Model code	Size
SNM	10-20

Type of nozzle: SNM
 Nozzle bore or thread size: (M10×1.25)
 Dimension from shoulder surface to nozzle top:※ (20mm)

※ In case of press fitting type without nozzle, this dimension is not indicated.

Precautions for Use

When the press fitting type Super Flexible Nozzle is used, a $\phi 15$ (H8) $^{+0.027}$ bore for fitting hole must be prepared and fitting is made from the 30° chamfered end of the outer body. In this case, the body portion should be pushed for press fitting.

When the screw fitting type Super Flexible Nozzle is used and prevention of oil leakage from the fitting part is required, it is recommended to wind sealing tape on the thread portion or use rubber packing for the shoulder face of the outer body.

The direction of lubrication can be adjusted by inserting a screwdriver, etc. in the bore of the nozzle.

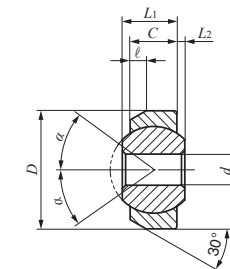
Special Specifications

Super Flexible Nozzles with special length are also available. In this case, specify the necessary nozzle length in units of 1 mm, but do not exceed the maximum length shown in the dimension table as "L".

Super Flexible Nozzles with curved nozzle end or with special bore diameter are also available. In this case, please contact IKO by preparing a drawing or sketch with necessary specifications.

SUPER FLEXIBLE NOZZLE

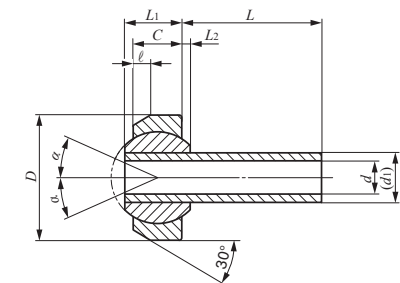
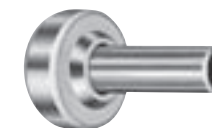
Press Fitting Type Without Nozzle



SNA

Identification number	Boundary dimensions mm						Ball dia. mm (inch)	Allowable tilting angle α degree
	d	D	L ₁	L ₂	C	ℓ		
SNA 4	4	15	7	1	6	2	11.112 (7/16)	36
SNA 6	6							24

Press Fitting Type With Nozzle

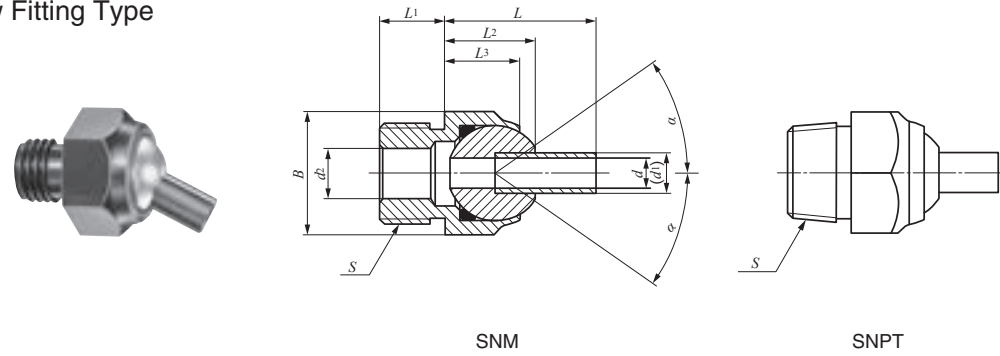


SNA

Identification number	Boundary dimensions mm									Ball dia. mm (inch)	Allowable tilting angle α degree	
	d	D	L			L ₁	L ₂	C	ℓ			d ₁
SNA 3-L	3	15	6	15	32	7	1	6	2	6	11.112 (7/16)	24
SNA 4-L	4		6	16	40							

SUPER FLEXIBLE NOZZLE

Screw Fitting Type



Identification number	Boundary dimensions mm										Ball dia. mm (inch)	Allowable tilting angle α degree		
	d	Thread S	L	L_1	L_2	L_3	d_1	d_2	Width across flats B	Width across corners (Ref.)				
SNM 10-L	4	M10×1.25	20	40	60	9	13	10.5	6	6	17	19.6	35	
SNPT 1/4-L		PT 1/4										12.700 ($\frac{1}{2}$)		
SNM 20-L	6	M20×1.5	30	50	70	13	18	15	8	10	24	27.7		
SNPT 3/8-L		PT 3/8										19.050 ($\frac{3}{4}$)		
SNM 24-L	8	M24×2.0	40	60	80	18	23	19	10	12	32	37		25.400 (1)
SNPT 1/2-L		PT 1/2												

PARTS FOR NEEDLE ROLLER BEARINGS

- Seals for Needle Roller Bearings
- Cir-clips for Needle Roller Bearings
- Needle Rollers



Seals for Needle Roller Bearings

Features

IKO Seals for Needle Roller Bearings have a low sectional height and consist of a sheet metal ring and special synthetic rubber.

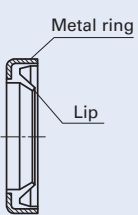
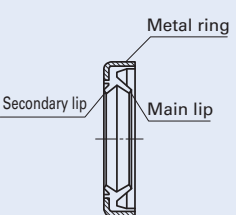
As these seals are manufactured to the same sectional height as IKO Needle Roller Bearings, grease leakage and the penetration of foreign particles can be effectively prevented by fitting them directly to the sides of combinable bearings shown in the dimension table.

When fitting seals to needle roller bearings with inner ring, wide inner rings (see page H2) must be used, as shown in the mounting examples.

Types

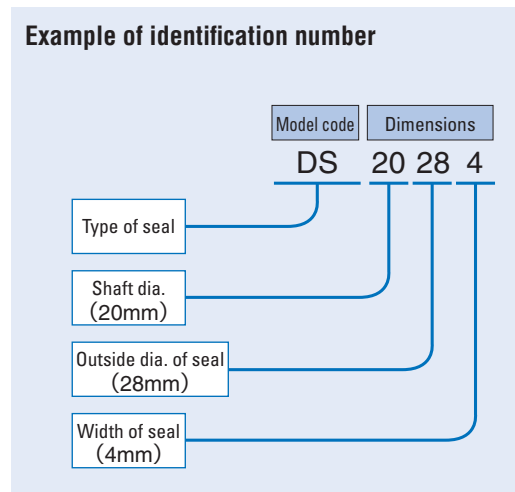
Seals for Needle Roller Bearings are available as shown in Table 1.

Table 1 Seal type

Type	Single lip	Double lips
Structure		
Model code	OS	DS

Identification Number

The identification number of Seals for Needle Roller Bearings consists of a model code and dimensions. An example of an identification number is shown as follows.



Accuracy

Tolerances of Seals for Needle Roller Bearings are based on JIS B 2402-1.

Tolerances of outside diameter and width are based on Tables 2 and 3, respectively.

Table 2 Tolerance of outside diameter unit: mm

Nominal outside diameter		Tolerance	
Over	Incl.	High	Low
—	30	+ 0.09	+ 0.04
30	50	+ 0.11	+ 0.05
50	80	+ 0.14	+ 0.06
80	120	+ 0.17	+ 0.08

Table 3 Tolerance of width unit: mm

Nominal size of width		Tolerance	
Over	Incl.	High	Low
—	6	+ 0.2	- 0.2
6	10	+ 0.3	- 0.3

Precautions for Use

① For the single lip OS type, the lip has to face inward when using the seal to prevent grease leakage, and outward to prevent the penetration of foreign particles. The DS type of double-lips is effective for prevention of grease leakage and dust penetration. However, when the main purpose is to prevent grease leakage, the main lip should face inward, and when used mainly to prevent dust penetration, it should face outward.

② The permissible temperature range is -20 ~ +100°C.

For use at higher or lower temperatures, a special seal is required. Please contact IKO for further information.

③ The limiting peripheral speed of shaft depends on the conditions of use, but is normally 6 to 8 m/s.

Double this speed is possible if the conditions (lubrication, temperature, shaft finish, etc.) are good.

Mounting

When inserting the shaft, damage to the lip should be prevented by chamfering the end of the shaft, as shown in the upper part of Fig. 1. When this cannot be performed, a mounting bushing should be used, as shown in the lower part of Fig. 1.

When press fitting the seal to the housing, do not strike it directly, but fit it gently, using a suitable tool.

To prevent early wear and heat generation at the seal surface, it is necessary to thickly coat the tip of the lip for the OS type, or to fill the space between the two lips for the DS type, with bearing grease.

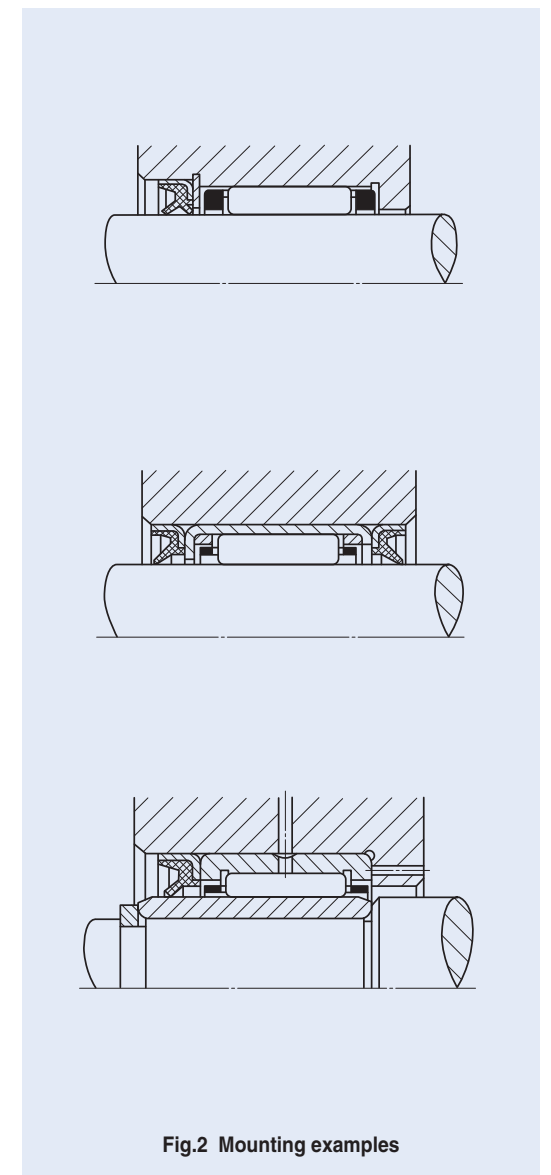
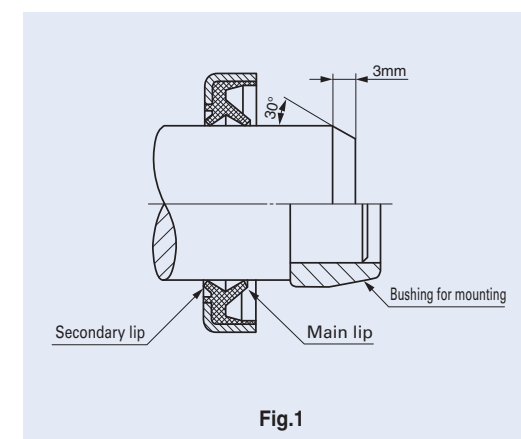
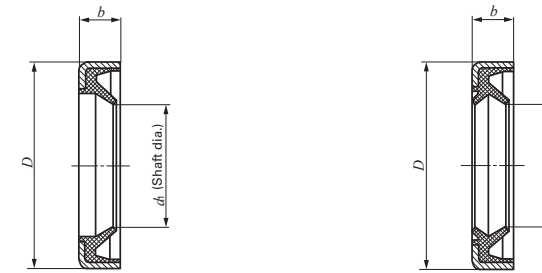


Fig.2 Mounting examples



Shaft dia. 6 – 15mm

Shaft dia. mm	Identification number		Boundary dimensions mm			Combinable bearings			
	Single lip	Double lips	d_1	D	b	TA···Z YT TLA···Z YTL	RNA TR TAF GTR	RNAF	NAX NBX
6	OS 6102.5	—	6	10	2.5	TLA 69Z	—	—	—
7	OS 7112.5	—	7	11	2.5	TLA 79Z	—	—	—
8	OS 8123	—	8	12	3	TLA 810Z	—	—	—
	OS 8153	—				TA 810Z TA 815Z TA 820Z YT 810	RNA 496 TAF 81512 TAF 81516	RNAF 81510	—
9	OS 9133	—	9	13	3	TLA 910Z TLA 912Z	—	—	—
	OS 9163	—				TA 912Z TA 916Z YT 912	TAF 91612 TAF 91616	—	—
10	OS 10143	—	10	14	3	TLA 1010Z TLA 1012Z TLA 1015Z	—	—	—
	OS 10173	—				TA 1010Z TA 1012Z TA 1015Z TA 1020Z	TAF 101712 TAF 101716	RNAF 101710	—



OS

DS

Shaft dia. mm	Identification number		Boundary dimensions mm			Combinable bearings			
	Single lip	Double lips	d_1	D	b	TA···Z YT TLA···Z YTL	RNA TR TAF GTR	RNAF	NAX NBX
12	OS 12163	—	12	16	3	TLA 1210Z YTL 1210	—	—	—
	OS 12183	—				TLA 1212Z	—	—	—
	OS 12193	—				TA 1212Z TA 1215Z TA 1220Z TA 1225Z YT 1212	TAF 121912 TAF 121916	—	—
13	OS 13193	—	13	19	3	TLA 1312Z	—	—	—
14	OS 14203	DS 14203	14	20	3	TLA 1412Z TLA 1416Z	—	—	—
	OS 14223	DS 14223				TA 1416Z TA 1420Z	RNA 4900 TAF 142216 TAF 142220	RNAF 142213 RNAFW 142220	—
15	OS 15213	DS 15213	15	21	3	TLA 1512Z TLA 1516Z TLA 1522Z	—	—	—
	OS 15223	DS 15223				TA 1510Z TA 1512Z TA 1515Z TA 1520Z TA 1525Z	—	—	—
	OS 15235	DS 15235				—	TAF 152316 TAF 152320	RNAF 152313 RNAFW 152320	—

L

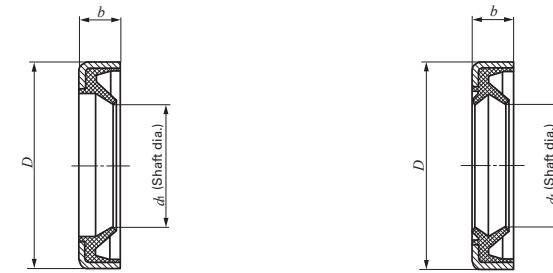
OS
DS

SEALS FOR NEEDLE ROLLER BEARINGS



Shaft dia. 16 – 19mm

Shaft dia. mm	Identification number		Boundary dimensions mm			Combinable bearings			
	Single lip	Double lips	d_1	D	b	TA···Z YT TLA···Z YTL	RNA TR TAF GTR	RNAF	NAX NBX
16	OS 16223	DS 16223	16	22	3	TLA 1612Z TLA 1616Z TLA 1622Z	—	—	—
	OS 16243	DS 16243	16	24	3	TA 1616Z TA 1620Z	RNA 4901 RNA 6901 TAF 162416 TAF 162420	RNAF 162413 RNAFW 162420	—
	OS 16285	DS 16285	16	28	5	—	—	RNAF 162812	—
17	OS 17233	DS 17233	17	23	3	TLA 1712Z	—	—	—
	OS 17243	DS 17243	17	24	3	TA 1715Z TA 1720Z TA 1725Z YT 1715 YT 1725	—	—	—
	OS 17253	DS 17253	17	25	3	—	TAF 172516 TAF 172520	RNAF 172513 RNAFW 172520	—



OS

DS

Shaft dia. mm	Identification number		Boundary dimensions mm			Combinable bearings			
	Single lip	Double lips	d_1	D	b	TA···Z YT TLA···Z YTL	RNA TR TAF GTR	RNAF	NAX NBX
18	OS 18243	DS 18243	18	24	3	TLA 1812Z TLA 1816Z	—	—	—
	OS 18253	DS 18253	18	25	3	TA 1813Z TA 1815Z TA 1817Z TA 1819Z TA 1820Z TA 1825Z	—	—	—
	OS 18264	DS 18264	18	26	4	—	RNA 49/14 TAF 182616 TAF 182620	RNAF 182613 RNAFW 182620	—
19	OS 19274	—	19	27	4	TA 1916Z TA 1920Z	TAF 192716 TAF 192720	—	—

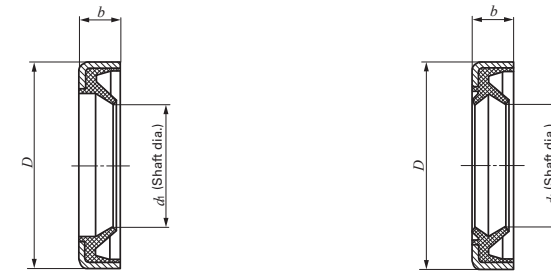
L

OS
DS



Shaft dia. 20 – 24mm

Shaft dia. mm	Identification number		Boundary dimensions mm			Combinable bearings			
	Single lip	Double lips	d_1	D	b	TA···Z YT TLA···Z YTL	RNA TR TAF GTR	RNAF	NAX NBX
20	OS 20264	DS 20264	20	26	4	TLA 2012Z TLA 2016Z TLA 2020Z TLA 2030Z	—	—	—
	OS 20274	DS 20274	20	27	4	TA 2015Z TA 2020Z TA 2025Z TA 2030Z YT 2015 YT 2025	—	—	—
	OS 20284	DS 20284	20	28	4	TA 202820Z YT 202820	RNA 4902 RNA 6902 TAF 202816 TAF 202820	RNAF 202813 RNAFW 202826	—
	OS 20304	DS 20304	20	30	4	—	—	—	NAX 2030 NBX 2030
	OS 20324	DS 20324	20	32	4	—	—	RNAF 203212 RNAFW 203224	—
	OS 20326	DS 20326	20	32	6	—	—	RNAF 203212 RNAFW 203224	—
	OS 21294	DS 21294	21	29	4	TA 2116Z TA 2120Z YT 2116 YT 2120	TAF 212916 TAF 212920	—	—



OS

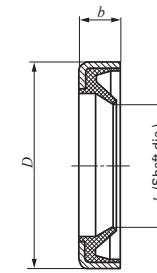
DS

Shaft dia. mm	Identification number		Boundary dimensions mm			Combinable bearings			
	Single lip	Double lips	d_1	D	b	TA···Z YT TLA···Z YTL	RNA TR TAF GTR	RNAF	NAX NBX
22	OS 22284	DS 22284	22	28	4	TLA 2212Z TLA 2216Z TLA 2220Z	—	—	—
	OS 22294	—	22	29	4	TA 2210Z TA 2215Z TA 2220Z TA 2225Z TA 2230Z	—	—	—
	OS 22304	DS 22304	22	30	4	TA 223016Z TA 223020Z YT 223016 YT 223020	RNA 4903 RNA 6903 TAF 223016 TAF 223020	RNAF 223013 RNAFW 223026	—
24	OS 24314	DS 24314	24	31	4	TA 2420Z TA 2428Z YT 2428	—	—	—
	OS 24324	DS 24324	24	32	4	TA 243216Z TA 243220Z YT 243216 YT 243220	TAF 243216 TAF 243220	—	—

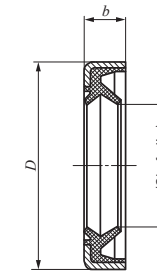


Shaft dia. 25 – 29mm

Shaft dia. mm	Identification number		Boundary dimensions mm			Combinable bearings			
	Single lip	Double lips	d_1	D	b	TA···Z YT TLA···Z YTL	RNA TR TAF GTR	RNAF	NAX NBX
25	OS 25324	DS 25324	25	32	4	TLA 2512Z TLA 2516Z TLA 2520Z TLA 2526Z TLAW 2538Z YTL 2526	—	—	—
	OS 25334	DS 25334	25	33	4	TA 2510Z TA 2515Z TA 2520Z TA 2525Z TA 2530Z YT 2510 YT 2515 YT 2520 YT 2525	TAF 253316 TAF 253320	—	—
	OS 25356	DS 25356	25	35	6	—	—	RNAF 253517 RNAFW 253526	—
	OS 25376	DS 25376	25	37	6	—	RNA 4904 RNA 6904	RNAF 253716 RNAFW 253732	NAX 2530 NBX 2530
	OS 26344	DS 26344	26	34	4	TA 2616Z TA 2620Z YT 2616 YT 2620	TAF 263416 TAF 263420	—	—
	OS 26344	DS 26344	26	34	4	TA 2616Z TA 2620Z YT 2616 YT 2620	TAF 263416 TAF 263420	—	—



OS



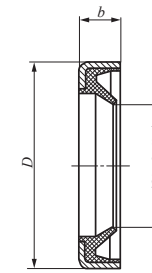
DS

Shaft dia. mm	Identification number		Boundary dimensions mm			Combinable bearings			
	Single lip	Double lips	d_1	D	b	TA···Z YT TLA···Z YTL	RNA TR TAF GTR	RNAF	NAX NBX
28	OS 28354	DS 28354	28	35	4	TLA 2816Z TLA 2820Z	—	—	—
	OS 28374	DS 28374	28	37	4	TA 2820Z TA 2830Z YT 2820	TAF 283720 TAF 283730	—	—
	OS 28396	DS 28396	28	39	6	—	RNA 49/22 RNA 69/22	—	—
	OS 28406	DS 28406	28	40	6	—	—	RNAF 284016 RNAFW 284032	—
29	OS 29384	DS 29384	29	38	4	TA 2920Z TA 2930Z YT 2920	TAF 293820 TAF 293830	—	—

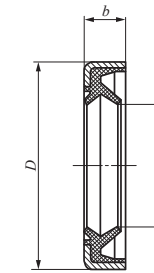


Shaft dia. 30 – 38mm

Shaft dia. mm	Identification number		Boundary dimensions mm			Combinable bearings			
	Single lip	Double lips	d_1	D	b	TA···Z YT TLA···Z YTL	RNA TR TAF GTR	RNAF	NAX NBX
30	OS 30374	DS 30374	30	37	4	TLA 3012Z TLA 3016Z TLA 3018Z TLA 3020Z TLA 3026Z TLAW 3038Z	—	—	—
	OS 30404	DS 30404	30	40	4	TA 3013Z TA 3015Z TA 3020Z TA 3025Z TA 3030Z	TAF 304020 TAF 304030	RNAF 304017 RNAFW 304026	—
	OS 30426	DS 30426	30	42	6	—	RNA 4905 RNA 6905	RNAF 304216 RNAFW 304232	NAX 3030 NBX 3030
32	OS 32424	DS 32424	32	42	4	TA 3220Z TA 3230Z YT 3220	TAF 324220 TAF 324230	—	—
	OS 32456	DS 32456	32	45	6	—	RNA 49/28 RNA 69/28 GTR 324530	—	—



OS



DS

Shaft dia. mm	Identification number		Boundary dimensions mm			Combinable bearings			
	Single lip	Double lips	d_1	D	b	TA···Z YT TLA···Z YTL	RNA TR TAF GTR	RNAF	NAX NBX
35	OS 35424	DS 35424	35	42	4	TLA 3512Z TLA 3516Z TLA 3520Z	—	—	—
	OS 35454	DS 35454	35	45	4	TA 3512Z TA 3515Z TA 3520Z TA 3525Z TA 3530Z	TAF 354520 TAF 354530	RNAF 354517 RNAFW 354526	—
	OS 35476	DS 35476	35	47	6	—	RNA 4906 RNA 6906	RNAF 354716 RNAFW 354732	NAX 3530 NBX 3530
37	OS 37474	DS 37474	37	47	4	TA 3720Z TA 3730Z YT 3720	TAF 374720 TAF 374730	—	—
38	OS 38484	DS 38484	38	48	4	TA 3815Z TA 3820Z TA 3825Z TA 3830Z TAW 3845Z	TAF 384820 TAF 384830	—	—
	OS 38506	DS 38506	38	50	6	—	—	—	—

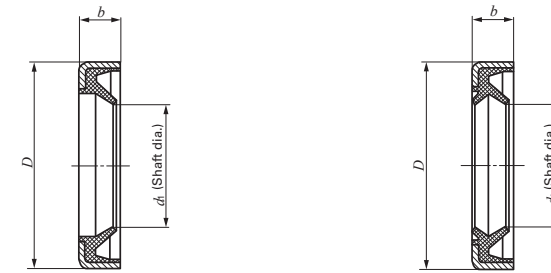
L

OS
DS



Shaft dia. 40 – 50mm

Shaft dia. mm	Identification number		Boundary dimensions mm			Combinable bearings			
	Single lip	Double lips	d_1	D	b	TA···Z YT TLA···Z YTL	RNA TR TAF GTR	RNAF	NAX NBX
40	OS 40474	DS 40474	40	47	4	TLA 4012Z TLA 4016Z TLA 4020Z	—	—	—
	OS 40504	DS 40504	40	50	4	TA 4015Z TA 4020Z TA 4025Z TA 4030Z TA 4040Z YT 4015 YT 4025	TAF 405020 TAF 405030	RNAF 405017 RNAFW 405034	—
	OS 40526	DS 40526	40	52	6	—	RNA 49/32 RNA 69/32	—	NAX 4032 NBX 4032
	OS 40556	DS 40556	40	55	6	—	TR 405520 GTR 405520	RNAF 405520 RNAFW 405540	—
42	OS 42557	DS 42557	42	55	7	—	RNA 4907 RNA 6907	—	—



OS

DS

Shaft dia. mm	Identification number		Boundary dimensions mm			Combinable bearings			
	Single lip	Double lips	d_1	D	b	TA···Z YT TLA···Z YTL	RNA TR TAF GTR	RNAF	NAX NBX
45	OS 45524	DS 45524	45	52	4	TLA 4516Z TLA 4520Z	—	—	—
	OS 45554	DS 45554	45	55	4	TA 4520Z TA 4525Z TA 4530Z TA 4540Z YT 4520 YT 4525	TAF 455520 TAF 455530	RNAF 455517 RNAFW 455534	—
	OS 45627	DS 45627	45	62	7	—	—	RNAF 456220 RNAFW 456240	—
48	OS 48627	DS 48627	48	62	7	—	RNA 4908 RNA 6908 TR 486230 GTR 486230	—	—
50	OS 50584	DS 50584	50	58	4	TLA 5020Z TLA 5025Z	—	—	—
	OS 50624	DS 50624	50	62	4	TA 5012Z TA 5015Z TA 5020Z TA 5025Z TA 5030Z TA 5040Z TAW5045Z	TAF 506225 TAF 506235	RNAF 506220 RNAFW 506240	NAX 5035 NBX 5035
	OS 50657	DS 50657	50	65	7	—	RNA 49/42	RNAF 506520 RNAFW 506540	—

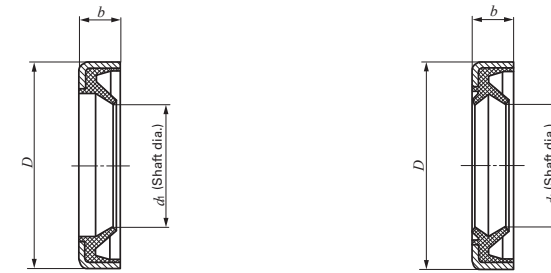
L

OS
DS



Shaft dia. 52 – 72mm

Shaft dia. mm	Identification number		Boundary dimensions mm			Combinable bearings				
	Single lip	Double lips	d_1	D	b	TA···Z YT TLA···Z YTL	RNA TR TAF GTR	RNAF	NAX NBX	
52	OS 52687	DS 52687	52	68	7	—	RNA 4909 RNA 6909	—	—	
55	OS 55674	DS 55674	55	67	4	TA 5520Z TA 5525Z TA 5530Z TA 5540Z TAW 5545Z TAW 5550Z	—	—	—	
	OS 55687	DS 55687	55	68	7	—	TAF 556825 TAF 556835	RNAF 556820 RNAFW 556840	—	
	OS 55727	—	55	72	7	—	—	RNAF 557220 RNAFW 557240	—	
58	OS 58727	DS 58727	58	72	7	—	RNA 4910 RNA 6910	—	—	
60	OS 60724	DS 60724	60	72	4	TA 6025Z TA 6030Z TA 6040Z TAW 6045Z TAW 6050Z	TAF 607225 TAF 607235	—	NAX 6040 NBX 6040	
	OS 60787	DS 60787	60	78	7	—	—	RNAF 607820 RNAFW 607840	—	
62	OS 62744	DS 62744	62	74	4	TA 6212Z	—	—	—	
63	OS 63807	DS 63807	63	80	7	—	RNA 4911 RNA 6911	—	—	



OS

DS

Shaft dia. mm	Identification number		Boundary dimensions mm			Combinable bearings				
	Single lip	Double lips	d_1	D	b	TA···Z YT TLA···Z YTL	RNA TR TAF GTR	RNAF	NAX NBX	
65	OS 65774	DS 65774	65	77	4	TA 6525Z TA 6530Z TAW 6545Z TAW 6550Z	—	—	—	
	OS 65857	DS 65857	65	85	7	—	—	RNAF 658530 RNAFW 658560	—	
68	OS 68857	DS 68857	68	85	7	—	RNA 4912 RNA 6912	—	—	
70	OS 70824	DS 70824	70	82	4	TA 7025Z TA 7030Z TA 7040Z TAW 7050Z	—	—	—	
	OS 70907	DS 70907	70	90	7	—	—	RNAF 709030 RNAFW 709060	—	
72	OS 72907	DS 72907	72	90	7	—	RNA 4913 RNA 6913	—	—	

L

OS
DS

Cir-clips for Needle Roller Bearings

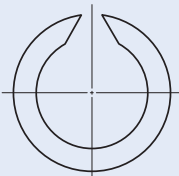
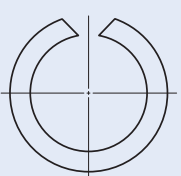
Features

IKO Cir-clips for Needle Roller Bearings have been specially designed for needle roller bearings on which, in many cases, generally available Cir-clips cannot be used. They have a low sectional height and are very rigid. They are made of spring steel. There are Cir-clips for shafts and for bores, and they are used for positioning to prevent bearing movement in the axial direction.

Types

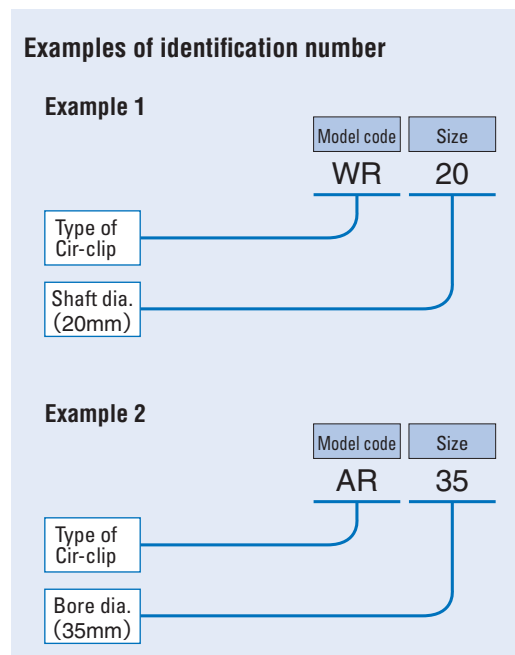
Cir-clips for Needle Roller Bearings are available as shown in Table. 1.

Table 1 Type of Cir-clip

Type	For shaft	For bore
Shape		
Model code	WR	AR

Identification number

The identification number of Cir-clips consists of a model code and a size as shown below.



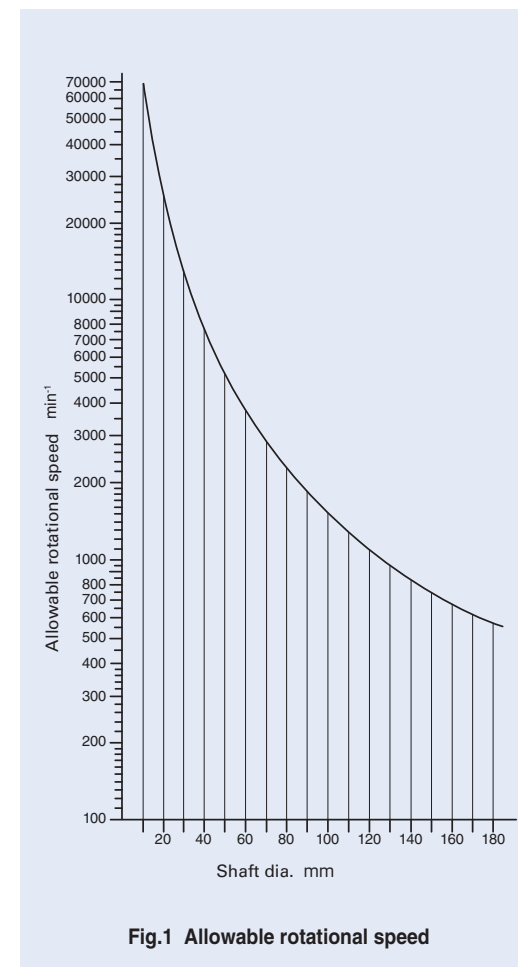
Allowable Rotational Speed

Cir-clips for Needle Roller Bearings are fixed in the groove with a certain amount of pressure on the bottom of the groove. In the case of Cir-clips for shaft WR type, the centrifugal force causes a decrease in the gripping pressure. Therefore, when using them at high rotational speeds, it is necessary to first check the allowable rotational speed shown in Fig.1.

Mounting

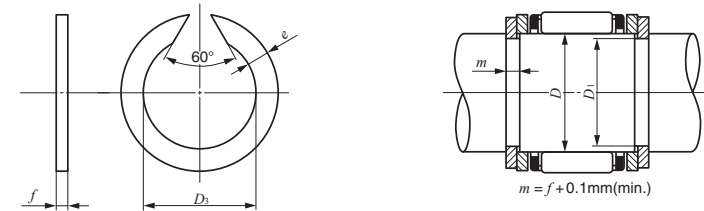
The mounting dimensions for Cir-clips for Needle Roller Bearings are shown in the dimension table. When using these Cir-clips to restrict the movement of the needle roller cage in the axial direction, it is recommended that a spacer be used between the Cir-clip and the cage. Spacers are not required at low rotational speeds.

When it is difficult to reach Cir-clips with dismounting tools and disassembly is difficult, or when the frequency of dismounting is high, it is necessary to consider the use of a retaining ring (JIS B 2804), although they have a higher sectional height.



CIR-CLIPS FOR NEEDLE ROLLER BEARINGS

For Shaft



WR

Shaft dia. 4 – 390mm

Identification number	Boundary dimensions mm					
	Shaft dia. D	D ₃ (Max.)	e	f	Groove dia. D ₁	Tolerance
WR 4	4	3.7	0.8	0.5	3.8	
WR 5	5	4.7	1	0.5	4.8	
WR 6	6	5.6	1.1	0.7	5.7	0
WR 7	7	6.5	1.2	0.7	6.7	-0.09
WR 8	8	7.4	1.3	1	7.6	
WR 9	9	8.4	1.3	1	8.6	
WR 10	10	9.4	1.3	1	9.6	
WR 11	11	10.2	1.3	1	10.5	
WR 12	12	11.2	1.3	1	11.5	
WR 13	13	12.1	1.3	1	12.5	0
WR 14	14	13.1	1.5	1.2	13.5	-0.11
WR 15	15	14	1.75	1.2	14.4	
WR 16	16	15	1.75	1.2	15.4	
WR 17	17	16	1.75	1.2	16.4	
WR 18	18	17	1.75	1.2	17.4	
WR 19	19	17.9	1.75	1.2	18.4	
WR 20	20	18.7	1.75	1.2	19.2	
WR 21	21	19.7	1.75	1.2	20.2	
WR 22	22	20.7	1.75	1.2	21.2	
WR 23	23	21.7	1.75	1.2	22.2	0
WR 24	24	22.5	1.75	1.2	23	-0.13
WR 25	25	23.5	1.75	1.2	24	
WR 26	26	24.5	1.75	1.2	25	
WR 28	28	26.5	2.3	1.5	27	
WR 29	29	27.5	2.3	1.5	28	
WR 30	30	28.5	2.3	1.5	29	
WR 32	32	30.2	2.3	1.5	30.8	
WR 35	35	33.2	2.3	1.5	33.8	
WR 36	36	34.2	2.3	1.5	34.8	0
WR 37	37	35.2	2.3	1.5	35.8	-0.16
WR 38	38	36.2	2.3	1.5	36.8	
WR 40	40	37.8	2.3	1.5	38.5	

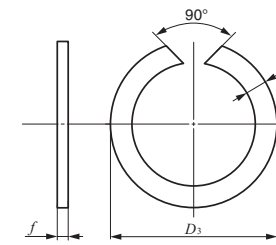
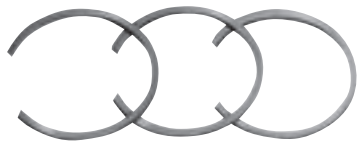
Identification number	Boundary dimensions mm					
	Shaft dia. D	D ₃ (Max.)	e	f	Groove dia. D ₁	Tolerance
WR 42	42	39.8	2.3	1.5	40.5	
WR 43	43	40.8	2.3	1.5	41.5	0
WR 45	45	42.8	2.3	1.5	43.5	-0.16
WR 47	47	44.8	2.3	1.5	45.5	
WR 50	50	47.8	2.3	1.5	48.5	
WR 52	52	49.8	2.3	1.5	50.5	
WR 55	55	52.6	2.3	1.5	53.5	
WR 60	60	57.6	2.3	1.5	58.5	
WR 63	63	60.6	2.3	1.5	61.5	0
WR 65	65	62.6	2.3	1.5	63.5	-0.19
WR 68	68	65.4	2.8	2	66.2	
WR 70	70	67.4	2.8	2	68.2	
WR 75	75	72.4	2.8	2	73.2	
WR 80	80	77.4	2.8	2	78.2	
WR 82	82	79.3	3.4	2.5	80.2	
WR 85	85	82	3.4	2.5	83	
WR 90	90	87	3.4	2.5	88	
WR 95	95	92	3.4	2.5	93	0
WR 100	100	97	3.4	2.5	98	-0.22
WR 105	105	101.7	3.4	2.5	102.7	
WR 110	110	106.7	3.4	2.5	107.7	
WR 115	115	111.7	3.4	2.5	112.7	
WR 120	120	116.7	3.4	2.5	117.7	
WR 125	125	121.7	3.4	2.5	122.7	
WR 130	130	126.7	3.4	2.5	127.7	
WR 135	135	131.6	4	2.5	132.4	
WR 140	140	136.6	4	2.5	137.4	
WR 145	145	141.6	4	2.5	142.4	0
WR 150	150	146.6	4	2.5	147.4	-0.25
WR 155	155	151.6	4	2.5	152.4	
WR 160	160	156.6	4	2.5	157.4	
WR 165	165	161.6	4	2.5	162.4	

Identification number	Boundary dimensions mm					
	Shaft dia. D	D ₃ (Max.)	e	f	Groove dia. D ₁	Tolerance
WR 170	170	166.6	4	2.5	167.4	0
WR 175	175	171.6	4	2.5	172.4	-0.25
WR 180	180	175.6	5	3	177	
WR 185	185	180.6	5	3	182	
WR 190	190	185.6	5	3	187	
WR 195	195	190.6	5	3	192	
WR 200	200	195.6	5	3	197	0
WR 210	210	205.6	5	3	207	-0.29
WR 220	220	215.6	5	3	217	
WR 230	230	225.6	5	3	227	
WR 240	240	235.6	5	3	237	
WR 260	260	253	7.5	4	255	
WR 265	265	258	7.5	4	260	
WR 270	270	263	7.5	4	265	
WR 280	280	273	7.5	4	275	0
WR 285	285	278	7.5	4	280	-0.32
WR 300	300	293	7.5	4	295	
WR 305	305	298	7.5	4	300	
WR 320	320	313	7.5	4	315	
WR 330	330	323	7.5	4	325	
WR 340	340	333	7.5	4	335	
WR 350	350	343	7.5	4	345	0
WR 360	360	353	7.5	4	355	-0.36
WR 370	370	363	7.5	4	365	
WR 390	390	383	7.5	4	385	

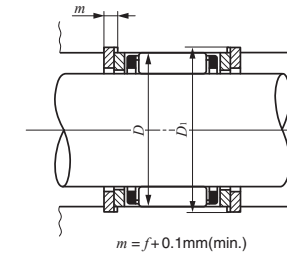


CIR-CLIPS FOR NEEDLE ROLLER BEARINGS

For Bore



AR



Bore dia. 7 – 440mm

Identification number	Boundary dimensions mm					
	Bore dia. D	D ₃ (Min.)	e	f	Groove dia. D ₁	Tolerance
AR 7	7	7.5	1	0.8	7.3	+0.09 0
AR 8	8	8.5	1	0.8	8.3	
AR 9	9	9.5	1.1	0.8	9.3	
AR 10	10	10.6	1.2	0.8	10.4	+0.11 0
AR 11	11	11.6	1.3	1	11.4	
AR 12	12	12.7	1.3	1	12.4	
AR 13	13	13.8	1.3	1	13.5	+0.13 0
AR 14	14	14.8	1.3	1	14.5	
AR 15	15	15.8	1.3	1	15.5	
AR 16	16	16.8	1.6	1.2	16.5	+0.19 0
AR 17	17	17.8	1.6	1.2	17.5	
AR 18	18	18.9	1.75	1.2	18.5	
AR 19	19	19.9	1.75	1.2	19.6	+0.22 0
AR 20	20	21	1.75	1.2	20.6	
AR 21	21	22	1.75	1.2	21.6	
AR 22	22	23	1.75	1.2	22.6	+0.25 0
AR 23	23	24	1.75	1.2	23.6	
AR 24	24	25.2	1.75	1.2	24.8	
AR 25	25	26.2	1.75	1.2	25.8	+0.29 0
AR 26	26	27.2	1.75	1.2	26.8	
AR 27	27	28.2	1.75	1.2	27.8	
AR 28	28	29.2	1.75	1.2	28.8	+0.32 0
AR 29	29	30.2	1.75	1.2	29.8	
AR 30	30	31.4	2.3	1.5	31	
AR 31	31	32.4	2.3	1.5	32	+0.36 0
AR 32	32	33.4	2.3	1.5	33	
AR 33	33	34.4	2.3	1.5	34	
AR 34	34	35.4	2.3	1.5	35	+0.4 0
AR 35	35	36.4	2.3	1.5	36	
AR 37	37	38.8	2.3	1.5	38.2	
AR 38	38	39.8	2.3	1.5	39.2	
AR 39	39	40.8	2.3	1.5	40.2	

Identification number	Boundary dimensions mm					
	Bore dia. D	D ₃ (Min.)	e	f	Groove dia. D ₁	Tolerance
AR 40	40	41.8	2.3	1.5	41.2	+0.16 0
AR 42	42	43.8	2.3	1.5	43.2	
AR 43	43	44.8	2.3	1.5	44.2	
AR 44	44	45.8	2.3	1.5	45.2	+0.19 0
AR 45	45	46.8	2.3	1.5	46.2	
AR 47	47	48.8	2.3	1.5	48.2	
AR 48	48	49.8	2.3	1.5	49.2	+0.22 0
AR 50	50	51.8	2.3	1.5	51.2	
AR 52	52	54.3	2.3	1.5	53.5	
AR 53	53	55.3	2.3	1.5	54.5	+0.25 0
AR 55	55	57.3	2.3	1.5	56.5	
AR 57	57	59.3	2.3	1.5	58.5	
AR 58	58	60.3	2.3	1.5	59.5	+0.29 0
AR 60	60	62.3	2.3	1.5	61.5	
AR 62	62	64.3	2.3	1.5	63.5	
AR 65	65	67.3	2.3	1.5	66.5	+0.32 0
AR 68	68	70.3	2.3	1.5	69.5	
AR 70	70	72.3	2.3	1.5	71.5	
AR 72	72	74.6	2.8	2	73.8	+0.36 0
AR 73	73	75.6	2.8	2	74.8	
AR 75	75	77.6	2.8	2	76.8	
AR 76	76	78.6	2.8	2	77.8	+0.4 0
AR 78	78	80.6	2.8	2	79.8	
AR 80	80	82.6	2.8	2	81.8	
AR 81	81	83.6	2.8	2	82.8	
AR 82	82	84.6	2.8	2	83.8	
AR 83	83	85.6	2.8	2	84.8	
AR 85	85	87.6	2.8	2	86.8	
AR 86	86	88.6	2.8	2	87.8	
AR 88	88	91	3.4	2.5	90	
AR 90	90	93	3.4	2.5	92	
AR 92	92	95	3.4	2.5	94	

Identification number	Boundary dimensions mm					
	Bore dia. D	D ₃ (Min.)	e	f	Groove dia. D ₁	Tolerance
AR 93	93	96	3.4	2.5	95	+0.22 0
AR 95	95	98	3.4	2.5	97	
AR 97	97	100	3.4	2.5	99	
AR 98	98	101	3.4	2.5	100	+0.25 0
AR 100	100	103	3.4	2.5	102	
AR 102	102	105.3	3.4	2.5	104.3	
AR 103	103	106.3	3.4	2.5	105.3	+0.29 0
AR 105	105	108.3	3.4	2.5	107.3	
AR 107	107	110.3	3.4	2.5	109.3	
AR 108	108	111.3	3.4	2.5	110.3	+0.32 0
AR 110	110	113.3	3.4	2.5	112.3	
AR 112	112	115.3	3.4	2.5	114.3	
AR 113	113	116.3	3.4	2.5	115.3	+0.36 0
AR 115	115	118.3	3.4	2.5	117.3	
AR 117	117	120.3	3.4	2.5	119.3	
AR 118	118	121.3	3.4	2.5	120.3	+0.4 0
AR 120	120	123.3	3.4	2.5	122.3	
AR 123	123	126.3	3.4	2.5	125.3	
AR 125	125	128.3	3.4	2.5	127.3	
AR 127	127	130.3	3.4	2.5	129.3	
AR 130	130	133.3	3.4	2.5	132.3	
AR 133	133	136.3	3.4	2.5	135.3	
AR 135	135	138.3	3.4	2.5	137.3	
AR 137	137	140.3	3.4	2.5	139.3	
AR 140	140	143.6	4	2.5	142.6	
AR 143	143	146.6	4	2.5	145.6	
AR 145	145	148.6	4	2.5	147.6	
AR 150	150	153.6	4	2.5	152.6	
AR 153	153	156.6	4	2.5	155.6	
AR 160	160	163.6	4	2.5	162.6	
AR 163	163	166.6	4	2.5	165.6	
AR 165	165	168.6	4	2.5	167.6	

Identification number	Boundary dimensions mm					
	Bore dia. D	D ₃ (Min.)	e	f	Groove dia. D ₁	Tolerance
AR 170	170	173.6	4	2.5	172.6	+0.25 0
AR 173	173	176.6	4	2.5	175.6	
AR 175	175	178.6	4	2.5	177.6	
AR 180	180	183.6	4	2.5	182.6	+0.29 0
AR 183	183	186.6	4	2.5	185.6	
AR 190	190	194.5	5	3	193	
AR 195	195	199.5	5	3	198	+0.32 0
AR 200	200	204.5	5	3	203	
AR 205	205	209.5	5	3	208	
AR 210	210	214.5	5	3	213	+0.36 0
AR 215	215	219.5	5	3	218	
AR 220	220	224.5	5	3	223	
AR 225	225	229.5	5	3	228	+0.4 0
AR 230	230	234.5	5	3	233	
AR 235	235	239.5	5	3	238	
AR 240	240	244.5	5	3	243	
AR 245	245	249.5	5	3	248	
AR 250	250	254.5	5	3	253	
AR 260	260	267	7.5	4	265	
AR 270	270	277	7.5	4	275	
AR 280	280	287	7.5	4	285	
AR 300	300	307	7.5	4	305	
AR 320	320	327	7.5	4	325	
AR 325	325	332	7.5	4	330	
AR 355	355	362	7.5	4	360	
AR 375	375	382	7.5	4	380	
AR 395	395	402	7.5	4	400	
AR 415	415	422	7.5	4	420	
AR 420	420	427	7.5	4	425	
AR 440	440	447	7.5	4	445	



Needle Rollers

Features

IKO Needle Rollers are made of high carbon chromium bearing steel. They are rigid and highly accurate and are finished to a hardness of 58HRC or more (See Table 1.) and a surface roughness of $0.1 \mu m R_a$ or less.

These needle rollers are widely used as rolling elements for bearings, and also as pins and shafts. Please contact IKO, if Needle Rollers made of stainless steel are required.

Table 1 Hardness

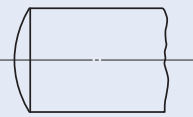
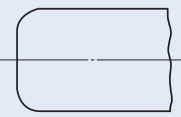
Nominal diameter D_w mm		Hardness	
Over	Incl.	HRC	HV
—	3	(60 ~ 67)	697 ~ 900
3	—	58 ~ 66	(653 ~ 865)

Remarks 1. Hardness is flat surface hardness.
2. The values in parentheses are converted values for reference.

End Shapes

Needle Rollers come in spherical and flat end shapes, as shown in Table 2. Please contact IKO, if other shapes are required.

Table 2 Shapes of ends

Type	Spherical end	Flat end
Shapes		
Symbol	A	F

Accuracy

The dimensional accuracy of Needle Rollers conforms to JIS B 1506 (Rolling bearings-Rollers), and is shown in Table 3.

The selective classification for the mean diameter tolerance is shown in Table 4. The selective classification rollers according to Table 4 can be provided as requested.

Table 3 Dimensional accuracy of needle rollers unit: μm

Class	Diameter variation in a single radial plane ⁽¹⁾ V_{DwP} (Max.)	Circularity ⁽¹⁾ Δ_R (Max.)	Gauge lot diameter variation ⁽¹⁾ V_{DwL} (Max.)	Deviation of a single length ⁽²⁾ Δ_{Lws}
2	1	1	2	h13
3	1.5	1.5	3	h13
5	2	2.5	5	h13

Notes ⁽¹⁾ Applicable to the measurement at the center of roller length

⁽²⁾ Tolerance is based on the classification according to the nominal length L_w .

Remark Any measured diameter along the total length of roller must not be larger than the actual maximum diameter at the center of roller length by the amount exceeding the values given below.

- 0.5 μm for Class 2
- 0.8 μm for Class 3
- 1 μm for Class 5

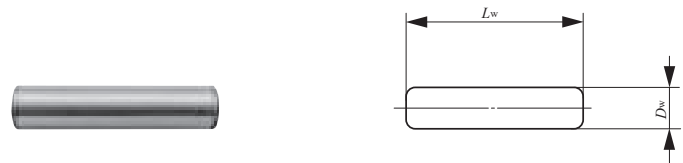
Table 4 Classification of needle rollers unit: μm

Classification symbol	Tolerance for mean dia.
C 3	0 ~ - 3
B 2	0 ~ - 2
B 4	- 2 ~ - 4
B 6	- 4 ~ - 6
B 8	- 6 ~ - 8
B10	- 8 ~ - 10

Use as Full-complement Bearings

For normal rotation, Needle Roller Bearings with cage are most suitable, but for low rotational speeds and for oscillating movement, full-complement bearings are also used.

If Needle Rollers are combined with a shaft and a housing which have been hardened and ground to form a suitable raceway surface, the combined assembly can be used as a full-complement bearing which has a large load capacity and a low sectional height. (See page A44, Design of shaft and housing.) Normally in this case, the radial clearance is made a little larger than that of a bearing with cage and the circumferential clearance is made to be approximately 1/10 of the diameter of needle rollers. When the bearing is used under severe conditions, please contact IKO for further information.



Roller dia. 1 – 6mm

Nominal dimensions mm			Nominal dimensions mm			Nominal dimensions mm		
D_w	L_w	Mass (Ref.) g	D_w	L_w	Mass (Ref.) g	D_w	L_w	Mass (Ref.) g
1	5.8	0.03	3.5	11.8	0.86	5	15.8	2.3
	6.8	0.04		13.8	1		17.8	2.6
	7.8	0.05		15.8	1.15		19.8	2.9
	9.8	0.06		17.8	1.29		21.8	3.2
1.5	5.8	0.08		19.8	1.44		23.8	3.5
	6.8	0.09		21.8	1.58		25.8	3.8
	7.8	0.1		23.8	1.73		27.8	4.1
	9.8	0.13		25.8	1.88		29.8	4.4
	11.8	0.16		27.8	2.1		31.8	4.7
	13.8	0.18		29.8	2.2		34.8	5.2
2	6.8	0.16	31.8	2.3	37.8	5.6		
	7.8	0.19	34.8	2.5	39.8	5.9		
	9.8	0.23	4	11.8	1.12	6	17.8	3.9
	11.8	0.28		13.8	1.31		19.8	4.3
	13.8	0.33		15.8	1.5		21.8	4.8
	15.8	0.38		17.8	1.69		23.8	5.2
	17.8	0.42		19.8	1.88		25.8	5.5
	19.8	0.47		21.8	2.1		27.8	6
2.5	7.8	0.29		23.8	2.3		29.8	6.4
	9.8	0.36		25.8	2.5		34.8	7.5
	11.8	0.44		27.8	2.6		39.8	8.6
	13.8	0.51		29.8	2.8		49.8	10.8
	15.8	0.59	31.8	3	59.8	13		
	17.8	0.66	34.8	3.3				
	19.8	0.73	37.8	3.6				
	21.8	0.81	39.8	3.8				
3	9.8	0.52	4.5	17.8	2.1			
	11.8	0.63		19.8	2.4			
	13.8	0.74		21.8	2.6			
	15.8	0.84		23.8	2.9			
	17.8	0.95		25.8	3.1			
	19.8	1.06		29.8	3.6			
	21.8	1.16	31.8	3.8				
	23.8	1.27	34.8	4.2				
	25.8	1.38	37.8	4.5				
	27.8	1.48	39.8	4.8				
	29.8	1.59	44.8	5.4				

Remark For the names of the needle rollers, nominal dimensions are used.
Needle Rollers other than those shown in the dimension table can also be manufactured. Please contact IKO for further information.

MISCELLANEOUS TABLES

MISCELLANEOUS TABLES

● Conversion Table of Units

Comparison table between SI units (system of international units), CGS units and gravitational system of units

Item	Length	Mass	Time	Acceleration	Force	Stress	Pressure
SI units	m	kg	s	m/s ²	N	Pa	Pa
CGS units	cm	g	s	Gal	dyn	dyn/cm ²	dyn/cm ²
Grav. units	m	kgf·s ² /m	s	m/s ²	kgf	kgf/m ²	kgf/m ²

Conversion rates into SI units

Item	Unit name	Symbol	Conversion rate into SI	SI unit name	Symbol
Angle	Degree	°	$\pi / 180$	Radian	rad
	Minute	'	$\pi / 10\ 800$		
	Second	"	$\pi / 648\ 000$		
Length	Meter	m	1	Meter	m
	Micronmeter	μ	10 ⁻⁶		
	Angstrom	Å	10 ⁻¹⁰		
	X-ray unit		$\approx 1.002\ 08 \times 10^{-13}$		
Nautical mile	n mile		1852		
Area	Square meter	m ²	1	Square meter	m ²
	Are	a	10 ²		
	Hectare	ha	10 ⁴		
Volume	Cubic meter	m ³	1	Cubic meter	m ³
	Liter	l, L	10 ⁻³		
Mass	Kilogram	kg	1	Kilogram	kg
	Ton	t	10 ³		
	Atomic mass unit	u	$\approx 1.660\ 57 \times 10^{-27}$		
Time	Second	s	1	Second	s
	Minute	min	60		
	Hour	h	3 600		
	Day	d	86 400		
Velocity	Meter per second	m/s	1	Meter per second	m/s
	Knot	kn	1 852/3 600		
Frequency and number of oscillations per time	Cycle	s ⁻¹	1	Hertz	Hz
Rotational speed	Rotation per minute	min ⁻¹	1/60	Per second	s ⁻¹
Angular velocity	Radian per second	rad/s	1	Radian per second	rad/s
Acceleration	Meter per square second	m/s ²	1	Meter per square second	m/s ²
	G	G	9.806 65		
Force	Kilogram force	kgf	9.806 65	Newton	N
	Ton force	tf	9 806.65		
	Dyne	dyn	10 ⁻⁵		
Moment of force	Kilogram force-meter	kgf·m	9.806 65	Newton-meter	N·m
Stress and pressure	Kilogram force per square meter	kgf/m ²	9.806 65	Pascal	Pa
	Kilogram force per square centimeter	kgf/cm ²	$9.806\ 65 \times 10^4$		
	Kilogram force per square millimeter	kgf/mm ²	$9.806\ 65 \times 10^6$		

Energy	Power	Temperature	Viscosity	Kinematic viscosity	Magnetic flux	Magnetic flux density	Magnetic field intensity
J	W	K	Pa·s	m ² /s	Wb	T	A/m
erg	erg/s	°C	P	St	Mx	Gs	Oe
kgf·m	kgf·m/s	°C	kgf·s/m ²	m ² /s	—	—	—

Item	Unit name	Symbol	Conversion rate into SI	SI unit name	Symbol
Pressure	Hydro-column meter	mH ₂ O	9 806.65	Pascal	Pa
	Mercurial column millimeter	mmHg	101 325/760		
	Torr	Torr	101 325/760		
	Atmosphere	atm	101 325		
Bar	bar	10 ⁵			
Energy	Erg	erg	10 ⁻⁷	Joule	J
	IT calorie	cal _{IT}	4.186 8		
	Kilogram force - meter	kgf·m	9.806 65		
	Kilowatt hour	kW·h	3.600×10^6		
	Horse power hour (French)	PS·h	$\approx 2.647\ 79 \times 10^6$		
Electron volt	eV	$\approx 1.602\ 19 \times 10^{-19}$			
Power	Watt	W	1	Watt	W
	Horse power (French)	PS	≈ 735.5		
	Kilogram force -meter per second	kgf·m/s	9.806 65		
Viscosity	Poise	P	10 ⁻¹	Pascal-second	Pa·s
	Centipoise	cP	10 ⁻³		
	Kilogram force-second per square meter	kgf·s/m ²	9.806 65		
Kinematic viscosity	Stokes	St	10 ⁻⁴	Square meter per second	m ² /s
	Centistokes	cSt	10 ⁻⁶		
Temperature	Degree	°C	+273.15	Kelvin	K
Radioactivity	Curie	Ci	3.7×10^{10}	Becquerel	Bq
Exposure dose	Roentgen	R	2.58×10^{-4}	Coulomb per kilogram	C/kg
Absorbed dose	Rad	rad	10 ⁻²	Gray	Gy
Dose equivalent	Rem	rem	10 ⁻²	Sievert	Sv
Magnetic flux	Maxwell	Mx	10 ⁻⁸	Weber	Wb
Magnetic flux density	Gamma	γ	10 ⁻⁹	Tesla	T
	Gauss	Gs	10 ⁻⁴		
Magnetic field intensity	Oersted	Oe	$10^3/4\ \pi$	Ampere per meter	A/m
Quantity of electricity	Coulomb	C	1	Coulomb	C
Electric potential difference	Volt	V	1	Volt	V
Electrostatic capacity	Farad	F	1	Farad	F
(Electric) resistance	Ohm	Ω	1	Ohm	Ω
(Electric) conductance	Siemens	S	1	Siemens	S
Inductance	Henry	H	1	Henry	H
Current	Ampere	A	1	Ampere	A

● Inch-mm Conversion Table

1 inch = 25.4 mm

inch		0"	1"	2"	3"	4"	5"	6"	7"	8"
Fraction	Decimal									
1 / 64"	0.015625	0.397	25.400	50.800	76.200	101.600	127.000	152.400	177.800	203.200
1 / 32"	0.031250	0.794	25.797	51.197	76.597	101.997	127.397	152.797	178.197	203.597
3 / 64"	0.046875	1.191	26.591	51.991	77.391	102.791	128.191	153.591	178.991	204.391
1 / 16"	0.062500	1.588	26.988	52.388	77.788	103.188	128.588	153.988	179.388	204.788
5 / 64"	0.078125	1.984	27.384	52.784	78.184	103.584	128.984	154.384	179.784	205.184
3 / 32"	0.093750	2.381	27.781	53.181	78.581	103.981	129.381	154.781	180.181	205.581
7 / 64"	0.109375	2.778	28.178	53.578	78.978	104.378	129.778	155.178	180.578	205.978
1 / 8"	0.125000	3.175	28.575	53.975	79.375	104.775	130.175	155.575	180.975	206.375
9 / 64"	0.140625	3.572	28.972	54.372	79.772	105.172	130.572	155.972	181.372	206.772
5 / 32"	0.156250	3.969	29.369	54.769	80.169	105.569	130.969	156.369	181.769	207.169
11 / 64"	0.171875	4.366	29.766	55.166	80.566	105.966	131.366	156.766	182.166	207.566
3 / 16"	0.187500	4.762	30.162	55.562	80.962	106.362	131.762	157.162	182.562	207.962
13 / 64"	0.203125	5.159	30.559	55.959	81.359	106.759	132.159	157.559	182.959	208.359
7 / 32"	0.218750	5.556	30.956	56.356	81.756	107.156	132.556	157.956	183.356	208.756
15 / 64"	0.234375	5.953	31.353	56.753	82.153	107.553	132.953	158.353	183.753	209.153
1 / 4"	0.250000	6.350	31.750	57.150	82.550	107.950	133.350	158.750	184.150	209.550
17 / 64"	0.265625	6.747	32.147	57.547	82.947	108.347	133.747	159.147	184.547	209.947
9 / 32"	0.281250	7.144	32.544	57.944	83.344	108.744	134.144	159.544	184.944	210.344
19 / 64"	0.296875	7.541	32.941	58.341	83.741	109.141	134.541	159.941	185.341	210.741
5 / 16"	0.312500	7.938	33.338	58.738	84.138	109.538	134.938	160.338	185.738	211.138
21 / 64"	0.328125	8.334	33.734	59.134	84.534	109.934	135.334	160.734	186.134	211.534
11 / 32"	0.343750	8.731	34.131	59.531	84.931	110.331	135.731	161.131	186.531	211.931
23 / 64"	0.359375	9.128	34.528	59.928	85.328	110.728	136.128	161.528	186.928	212.328
3 / 8"	0.375000	9.525	34.925	60.325	85.725	111.125	136.525	161.925	187.325	212.725
25 / 64"	0.390625	9.922	35.322	60.722	86.122	111.522	136.922	162.322	187.722	213.122
13 / 32"	0.406250	10.319	35.719	61.119	86.519	111.919	137.319	162.719	188.119	213.519
27 / 64"	0.421875	10.716	36.116	61.516	86.916	112.316	137.716	163.116	188.516	213.916
7 / 16"	0.437500	11.112	36.512	61.912	87.312	112.712	138.112	163.512	188.912	214.312
29 / 64"	0.453125	11.509	36.909	62.309	87.709	113.109	138.509	163.909	189.309	214.709
15 / 32"	0.468750	11.906	37.306	62.706	88.106	113.506	138.906	164.306	189.706	215.106
31 / 64"	0.484375	12.303	37.703	63.103	88.503	113.903	139.303	164.703	190.103	215.503
1 / 2"	0.500000	12.700	38.100	63.500	88.900	114.300	139.700	165.100	190.500	215.900

1 inch = 25.4 mm

inch		0"	1"	2"	3"	4"	5"	6"	7"	8"
Fraction	Decimal									
33 / 64"	0.515625	13.097	38.497	63.897	89.297	114.697	140.097	165.497	190.897	216.297
17 / 32"	0.531250	13.494	38.894	64.294	89.694	115.094	140.494	165.894	191.294	216.694
35 / 64"	0.546875	13.891	39.291	64.691	90.091	115.491	140.891	166.291	191.691	217.091
9 / 16"	0.562500	14.288	39.688	65.088	90.488	115.888	141.288	166.688	192.088	217.488
37 / 64"	0.578125	14.684	40.084	65.484	90.884	116.284	141.684	167.084	192.484	217.884
19 / 32"	0.593750	15.081	40.481	65.881	91.281	116.681	142.081	167.481	192.881	218.281
39 / 64"	0.609375	15.478	40.878	66.278	91.678	117.078	142.478	167.878	193.278	218.678
5 / 8"	0.625000	15.875	41.275	66.675	92.075	117.475	142.875	168.275	193.675	219.075
41 / 64"	0.640625	16.272	41.672	67.072	92.472	117.872	143.272	168.672	194.072	219.472
21 / 32"	0.656250	16.669	42.069	67.469	92.869	118.269	143.669	169.069	194.469	219.869
43 / 64"	0.671875	17.066	42.466	67.866	93.266	118.666	144.066	169.466	194.866	220.266
11 / 16"	0.687500	17.462	42.862	68.262	93.662	119.062	144.462	169.862	195.262	220.662
45 / 64"	0.703125	17.859	43.259	68.659	94.059	119.459	144.859	170.259	195.659	221.059
23 / 32"	0.718750	18.256	43.656	69.056	94.456	119.856	145.256	170.656	196.056	221.456
47 / 64"	0.734375	18.653	44.053	69.453	94.853	120.253	145.653	171.053	196.453	221.853
3 / 4"	0.750000	19.050	44.450	69.850	95.250	120.650	146.050	171.450	196.850	222.250
49 / 64"	0.765625	19.447	44.847	70.247	95.647	121.047	146.447	171.847	197.247	222.647
25 / 32"	0.781250	19.844	45.244	70.644	96.044	121.444	146.844	172.244	197.644	223.044
51 / 64"	0.796875	20.241	45.641	71.041	96.441	121.841	147.241	172.641	198.041	223.441
13 / 16"	0.812500	20.638	46.038	71.438	96.838	122.238	147.638	173.038	198.438	223.838
53 / 64"	0.828125	21.034	46.434	71.834	97.234	122.634	148.034	173.434	198.834	224.234
27 / 32"	0.843750	21.431	46.831	72.231	97.631	123.031	148.431	173.831	199.231	224.631
55 / 64"	0.859375	21.828	47.228	72.628	98.028	123.428	148.828	174.228	199.628	225.028
7 / 8"	0.875000	22.225	47.625	73.025	98.425	123.825	149.225	174.625	200.025	225.425
57 / 64"	0.890625	22.622	48.022	73.422	98.822	124.222	149.622	175.022	200.422	225.822
29 / 32"	0.906250	23.019	48.419	73.819	99.219	124.619	150.019	175.419	200.819	226.219
59 / 64"	0.921875	23.416	48.816	74.216	99.616	125.016	150.416	175.816	201.216	226.616
15 / 16"	0.937500	23.812	49.212	74.612	100.012	125.412	150.812	176.212	201.612	227.012
61 / 64"	0.953125	24.209	49.609	75.009	100.409	125.809	151.209	176.609	202.009	227.409
31 / 32"	0.968750	24.606	50.006	75.406	100.806	126.206	151.606	177.006	202.406	227.806
63 / 64"	0.984375	25.003	50.403	75.803	101.203	126.603	152.003	177.403	202.803	228.203

● **Hardness Conversion Table (Reference)**

Rockwell C scale hardness Load 1471N	Vickers' hardness	Brinell hardness		Rockwell hardness		Shore hardness
		Standard ball	Tungsten carbide ball	A scale Load 588.4N Diamond circular cone	B scale Load 980.7N 1/16" ball	
HRC	HV					HS
68	940	—	—	85.6	—	97
67	900	—	—	85.0	—	95
66	865	—	—	84.5	—	92
65	832	—	(739)	83.9	—	91
64	800	—	(722)	83.4	—	88
63	772	—	(705)	82.8	—	87
62	746	—	(688)	82.3	—	85
61	720	—	(670)	81.8	—	83
60	697	—	(654)	81.2	—	81
59	674	—	(634)	80.7	—	80
58	653	—	615	80.1	—	78
57	633	—	595	79.6	—	76
56	613	—	577	79.0	—	75
55	595	—	560	78.5	—	74
54	577	—	543	78.0	—	72
53	560	—	525	77.4	—	71
52	544	(500)	512	76.8	—	69
51	528	(487)	496	76.3	—	68
50	513	(475)	481	75.9	—	67
49	498	(464)	469	75.2	—	66
48	484	451	455	74.7	—	64
47	471	442	443	74.1	—	63
46	458	432	432	73.6	—	62
45	446	421	421	73.1	—	60
44	434	409	409	72.5	—	58
43	423	400	400	72.0	—	57
42	412	390	390	71.5	—	56
41	402	381	381	70.9	—	55
40	392	371	371	70.4	—	54
39	382	362	362	69.9	—	52

Rockwell C scale hardness Load 1471N	Vickers' hardness	Brinell hardness		Rockwell hardness		Shore hardness
		Standard ball	Tungsten carbide ball	A scale Load 588.4N Diamond circular cone	B scale Load 980.7N 1/16" ball	
HRC	HV					HS
38	372	353	353	69.4	—	51
37	363	344	344	68.9	—	50
36	354	336	336	68.4	(109.0)	49
35	345	327	327	67.9	(108.5)	48
34	336	319	319	67.4	(108.0)	47
33	327	311	311	66.8	(107.5)	46
32	318	301	301	66.3	(107.0)	44
31	310	294	294	65.8	(106.0)	43
30	302	286	286	65.3	(105.5)	42
29	294	279	279	64.7	(104.5)	41
28	286	271	271	64.3	(104.0)	41
27	279	264	264	63.8	(103.0)	40
26	272	258	258	63.3	(102.5)	38
25	266	253	253	62.8	(101.5)	38
24	260	247	247	62.4	(101.0)	37
23	254	243	243	62.0	100.0	36
22	248	237	237	61.5	99.0	35
21	243	231	231	61.0	98.5	35
20	238	226	226	60.5	97.8	34
(18)	230	219	219	—	96.7	33
(16)	222	212	212	—	95.5	32
(14)	213	203	203	—	93.9	31
(12)	204	194	194	—	92.3	29
(10)	196	187	187	—	90.7	28
(8)	188	179	179	—	89.5	27
(6)	180	171	171	—	87.1	26
(4)	173	165	165	—	85.5	25
(2)	166	158	158	—	83.5	24
(0)	160	152	152	—	81.7	24

● Tolerance of Shaft Diameter

unit : μm

Nominal Diameter mm		b12		c12		d6		e6		e12		f5		f6		g5	
Over	Incl.	High	Low	High	Low	High	Low	High	Low	High	Low	High	Low	High	Low	High	Low
—	3	-140	-240	-60	-160	-20	-26	-14	-20	-14	-114	-6	-10	-6	-12	-2	-6
3	6	-140	-260	-70	-190	-30	-38	-20	-28	-20	-140	-10	-15	-10	-18	-4	-9
6	10	-150	-300	-80	-230	-40	-49	-25	-34	-25	-175	-13	-19	-13	-22	-5	-11
10	18	-150	-330	-95	-275	-50	-61	-32	-43	-32	-212	-16	-24	-16	-27	-6	-14
18	30	-160	-370	-110	-320	-65	-78	-40	-53	-40	-250	-20	-29	-20	-33	-7	-16
30	40	-170	-420	-120	-370	-80	-96	-50	-66	-50	-300	-25	-36	-25	-41	-9	-20
40	50	-180	-430	-130	-380												
50	65	-190	-490	-140	-440	-100	-119	-60	-79	-60	-360	-30	-43	-30	-49	-10	-23
65	80	-200	-500	-150	-450												
80	100	-220	-570	-170	-520	-120	-142	-72	-94	-72	-422	-36	-51	-36	-58	-12	-27
100	120	-240	-590	-180	-530												
120	140	-260	-660	-200	-600	-145	-170	-85	-110	-85	-485	-43	-61	-43	-68	-14	-32
140	160	-280	-680	-210	-610												
160	180	-310	-710	-230	-630												
180	200	-340	-800	-240	-700	-170	-199	-100	-129	-100	-560	-50	-70	-50	-79	-15	-35
200	225	-380	-840	-260	-720												
225	250	-420	-880	-280	-740												
250	280	-480	-1000	-300	-820	-190	-222	-110	-142	-110	-630	-56	-79	-56	-88	-17	-40
280	315	-540	-1060	-330	-850												
315	355	-600	-1170	-360	-930	-210	-246	-125	-161	-125	-695	-62	-87	-62	-98	-18	-43
355	400	-680	-1250	-400	-970												
400	450	-760	-1390	-440	-1070	-230	-270	-135	-175	-135	-765	-68	-95	-68	-108	-20	-47
450	500	-840	-1470	-480	-1110												

Nominal Diameter mm		g6		h5		h6		h7		h8		h9		h10		h11		Nominal Diameter mm	
High	Low	High	Low	High	Low	High	Low	High	Low	High	Low	High	Low	High	Low	High	Low	Over	Incl.
-2	-8	0	-4	0	-6	0	-10	0	-14	0	-25	0	-40	0	-60	—	3	—	3
-4	-12	0	-5	0	-8	0	-12	0	-18	0	-30	0	-48	0	-75	3	6	3	6
-5	-14	0	-6	0	-9	0	-15	0	-22	0	-36	0	-58	0	-90	6	10	6	10
-6	-17	0	-8	0	-11	0	-18	0	-27	0	-43	0	-70	0	-110	10	18	10	18
-7	-20	0	-9	0	-13	0	-21	0	-33	0	-52	0	-84	0	-130	18	30	18	30
-9	-25	0	-11	0	-16	0	-25	0	-39	0	-62	0	-100	0	-160	30	40	30	40
-10	-29	0	-13	0	-19	0	-30	0	-46	0	-74	0	-120	0	-190	40	50	40	50
-12	-34	0	-15	0	-22	0	-35	0	-54	0	-87	0	-140	0	-220	50	65	50	65
-14	-39	0	-18	0	-25	0	-40	0	-63	0	-100	0	-160	0	-250	65	80	65	80
-15	-44	0	-20	0	-29	0	-46	0	-72	0	-115	0	-185	0	-290	80	100	80	100
-17	-49	0	-23	0	-32	0	-52	0	-81	0	-130	0	-210	0	-320	100	120	100	120
-18	-54	0	-25	0	-36	0	-57	0	-89	0	-140	0	-230	0	-360	120	140	120	140
-20	-60	0	-27	0	-40	0	-63	0	-97	0	-155	0	-250	0	-400	140	160	140	160
																		160	180
																		180	200
																		200	225
																		225	250
																		250	280
																		280	315
																		315	355
																		355	400
																		400	450
																		450	500

unit : μm

Nominal Diameter mm		h12		h13		js5		j5		js6		j6		j7		k5	
Over	Incl.	High	Low	High	Low	High	Low	High	Low	High	Low	High	Low	High	Low	High	Low
—	3	0	-100	0	-140	+2	-2	+2	-2	+3	-3	+4	-2	+6	-4	+4	0
3	6	0	-120	0	-180	+2.5	-2.5	+3	-2	+4	-4	+6	-2	+8	-4	+6	+1
6	10	0	-150	0	-220	+3	-3	+4	-2	+4.5	-4.5	+7	-2	+10	-5	+7	+1
10	18	0	-180	0	-270	+4	-4	+5	-3	+5.5	-5.5	+8	-3	+12	-6	+9	+1
18	30	0	-210	0	-330	+4.5	-4.5	+5	-4	+6.5	-6.5	+9	-4	+13	-8	+11	+2
30	40	0	-250	0	-390	+5.5	-5.5	+6	-5	+8	-8	+11	-5	+15	-10	+13	+2
40	50																
50	65	0	-300	0	-460	+6.5	-6.5	+6	-7	+9.5	-9.5	+12	-7	+18	-12	+15	+2
65	80																
80	100	0	-350	0	-540	+7.5	-7.5	+6	-9	+11	-11	+13	-9	+20	-15	+18	+3
100	120																
120	140	0	-400	0	-630	+9	-9	+7	-11	+12.5	-12.5	+14	-11	+22	-18	+21	+3
140	160																
160	180																
180	200	0	-460	0	-720	+10	-10	+7	-13	+14.5	-14.5	+16	-13	+25	-21	+24	+4
200	225																
225	250																
250	280	0	-520	0	-810	+11.5	-11.5	+7	-16	+16	-16	+16	-16	+26	-26	+27	+4
280	315																
315	355	0	-570	0	-890	+12.5	-12.5	+7	-18	+18	-18	+18	-18	+29	-28	+29	+4
355	400																
400	450	0	-630	0	-970	+13.5	-13.5	+7	-20	+20	-20	+20	-20	+31	-32	+32	+5
450	500																

Nominal Diameter mm		k6		m5		m6		n5		n6		p6		Nominal Diameter mm	
High	Low	High	Low	High	Low	High	Low	High	Low	High	Low	High	Low	Over	Incl.
+6	0	+6	+2	+8	+2	+8	+4	+10	+4	+12	+6	—	3	—	3
+9	+1	+9	+4	+12	+4	+13	+8	+16	+8	+20	+12	3	6	3	6
+10	+1	+12	+6	+15	+6	+16	+10	+19	+10	+24	+15	6	10	6	10
+12	+1	+15	+7	+18	+7	+20	+12	+23	+12	+29	+18	10	18	10	18
+15	+2	+17	+8	+21	+8	+24	+15	+28	+15	+35	+22	18	30	18	30
+18	+2	+20	+9	+25	+9	+28	+17	+33	+17	+42	+26	30	40	30	40
+21	+2	+24	+11	+30	+11	+33	+20	+39	+20	+51	+32	40	50	40	50
+25	+3	+28	+13	+35	+13	+38	+23	+45	+23	+59	+37	50	65	50	65
+28	+3	+33	+15	+40	+15	+45	+27	+52	+27	+68	+43	65	80	65	80
+33	+4	+37	+17	+46	+17	+51	+31	+60	+31	+79	+50	80	100	80	100
+36	+4	+43	+20	+52	+20	+57	+34	+66	+34	+88	+56	100	120	100	120
+40	+4	+46	+21	+57	+21	+62	+37	+73	+37	+98	+62	120	140	120	140
+45	+5	+50	+23	+63	+23	+67	+40	+80	+40	+108	+68	140	160	140	160
														160	180
														180	200
														200	225
														225	250
														250	280
														280	315
														315	355
														355	400
														400	450
														450	500

● Tolerance of Housing Bore Diameter

unit : μm

Nominal Diameter mm		B12		E7		E11		E12		F6		F7		G6		G7	
Over	Incl.	High	Low	High	Low	High	Low	High	Low	High	Low	High	Low	High	Low	High	Low
—	3	+240	+140	+24	+14	+74	+14	+114	+14	+12	+6	+16	+6	+8	+2	+12	+2
3	6	+260	+140	+32	+20	+95	+20	+140	+20	+18	+10	+22	+10	+12	+4	+16	+4
6	10	+300	+150	+40	+25	+115	+25	+175	+25	+22	+13	+28	+13	+14	+5	+20	+5
10	18	+330	+150	+50	+32	+142	+32	+212	+32	+27	+16	+34	+16	+17	+6	+24	+6
18	30	+370	+160	+61	+40	+170	+40	+250	+40	+33	+20	+41	+20	+20	+7	+28	+7
30	40	+420	+170	+75	+50	+210	+50	+300	+50	+41	+25	+50	+25	+25	+9	+34	+9
40	50	+430	+180														
50	65	+490	+190	+90	+60	+250	+60	+360	+60	+49	+30	+60	+30	+29	+10	+40	+10
65	80	+500	+200														
80	100	+570	+220	+107	+72	+292	+72	+422	+72	+58	+36	+71	+36	+34	+12	+47	+12
100	120	+590	+240														
120	140	+660	+260	+125	+85	+335	+85	+485	+85	+68	+43	+83	+43	+39	+14	+54	+14
140	160	+680	+280														
160	180	+710	+310														
180	200	+800	+340	+146	+100	+390	+100	+560	+100	+79	+50	+96	+50	+44	+15	+61	+15
200	225	+840	+380														
225	250	+880	+420														
250	280	+1000	+480	+162	+110	+430	+110	+630	+110	+88	+56	+108	+56	+49	+17	+69	+17
280	315	+1060	+540														
315	355	+1170	+600	+182	+125	+485	+125	+695	+125	+98	+62	+119	+62	+54	+18	+75	+18
355	400	+1250	+680														
400	450	+1390	+760	+198	+135	+535	+135	+765	+135	+108	+68	+131	+68	+60	+20	+83	+20
450	500	+1470	+840														

H6		H7		H8		H9		H10		H11		JS6		J6		Nominal Diameter mm	
High	Low	High	Low	High	Low	High	Low	High	Low	High	Low	High	Low	High	Low	Over	Incl.
+6	0	+10	0	+14	0	+25	0	+40	0	+60	0	+3	-3	+2	-4	—	3
+8	0	+12	0	+18	0	+30	0	+48	0	+75	0	+4	-4	+5	-3	3	6
+9	0	+15	0	+22	0	+36	0	+58	0	+90	0	+4.5	-4.5	+5	-4	6	10
+11	0	+18	0	+27	0	+43	0	+70	0	+110	0	+5.5	-5.5	+6	-5	10	18
+13	0	+21	0	+33	0	+52	0	+84	0	+130	0	+6.5	-6.5	+8	-5	18	30
+16	0	+25	0	+39	0	+62	0	+100	0	+160	0	+8	-8	+10	-6	30	40
																40	50
+19	0	+30	0	+46	0	+74	0	+120	0	+190	0	+9.5	-9.5	+13	-6	50	65
																65	80
+22	0	+35	0	+54	0	+87	0	+140	0	+220	0	+11	-11	+16	-6	80	100
																100	120
+25	0	+40	0	+63	0	+100	0	+160	0	+250	0	+12.5	-12.5	+18	-7	120	140
																140	160
																160	180
+29	0	+46	0	+72	0	+115	0	+185	0	+290	0	+14.5	-14.5	+22	-7	180	200
																200	225
																225	250
+32	0	+52	0	+81	0	+130	0	+210	0	+320	0	+16	-16	+25	-7	250	280
																280	315
+36	0	+57	0	+89	0	+140	0	+230	0	+360	0	+18	-18	+29	-7	315	355
																355	400
+40	0	+63	0	+97	0	+155	0	+250	0	+400	0	+20	-20	+33	-7	400	450
																450	500

Nominal Diameter mm		JS7		J7		K5		K6		K7		M6		M7		N6	
Over	Incl.	High	Low	High	Low	High	Low	High	Low	High	Low	High	Low	High	Low	High	Low
—	3	+5	-5	+4	-6	0	-4	0	-6	0	-10	-2	-8	-2	-12	-4	-10
3	6	+6	-6	+6	-6	0	-5	+2	-6	+3	-9	-1	-9	0	-12	-5	-13
6	10	+7	-7	+8	-7	+1	-5	+2	-7	+5	-10	-3	-12	0	-15	-7	-16
10	18	+9	-9	+10	-8	+2	-6	+2	-9	+6	-12	-4	-15	0	-18	-9	-20
18	30	+10	-10	+12	-9	+1	-8	+2	-11	+6	-15	-4	-17	0	-21	-11	-24
30	40	+12	-12	+14	-11	+2	-9	+3	-13	+7	-18	-4	-20	0	-25	-12	-28
40	50																
50	65	+15	-15	+18	-12	+3	-10	+4	-15	+9	-21	-5	-24	0	-30	-14	-33
65	80																
80	100	+17	-17	+22	-13	+2	-13	+4	-18	+10	-25	-6	-28	0	-35	-16	-38
100	120																
120	140	+20	-20	+26	-14	+3	-15	+4	-21	+12	-28	-8	-33	0	-40	-20	-45
140	160																
160	180																
180	200	+23	-23	+30	-16	+2	-18	+5	-24	+13	-33	-8	-37	0	-46	-22	-51
200	225																
225	250																
250	280	+26	-26	+36	-16	+3	-20	+5	-27	+16	-36	-9	-41	0	-52	-25	-57
280	315																
315	355	+28	-28	+39	-18	+3	-22	+7	-29	+17	-40	-10	-46	0	-57	-26	-62
355	400																
400	450	+31	-31	+43	-20	+2	-25	+8	-32	+18	-45	-10	-50	0	-63	-27	-67
450	500																

unit : μm

N7		P6		P7		R7		S7		Nominal Diameter mm	
High	Low	High	Low	High	Low	High	Low	High	Low	Over	Incl.
-4	-14	-6	-12	-6	-16	-10	-20	-14	-24	—	3
-4	-16	-9	-17	-8	-20	-11	-23	-15	-27	3	6
-4	-19	-12	-21	-9	-24	-13	-28	-17	-32	6	10
-5	-23	-15	-26	-11	-29	-16	-34	-21	-39	10	18
-7	-28	-18	-31	-14	-35	-20	-41	-27	-48	18	30
-8	-33	-21	-37	-17	-42	-25	-50	-34	-59	30	40
										40	50
-9	-39	-26	-45	-21	-51	-30	-60	-42	-72	50	65
										65	80
-10	-45	-30	-52	-24	-59	-38	-73	-58	-93	80	100
										100	120
-12	-52	-36	-61	-28	-68	-48	-88	-77	-117	120	140
										140	160
										160	180
-14	-60	-41	-70	-33	-79	-60	-106	-105	-151	180	200
										200	225
										225	250
-14	-66	-47	-79	-36	-88	-74	-126	-138	-190	250	280
										280	315
-16	-73	-51	-87	-41	-98	-87	-144	-169	-226	315	355
										355	400
-17	-80	-55	-95	-45	-108	-103	-166	-209	-272	400	450
										450	500

N-lbf Conversion Table

N		lbf	N		lbf	N		lbf
4.448	1	0.225	151.24	34	7.643	298.03	67	15.062
8.896	2	0.450	155.69	35	7.868	302.48	68	15.287
13.345	3	0.674	160.14	36	8.093	306.93	69	15.512
17.793	4	0.899	164.58	37	8.318	311.38	70	15.737
22.241	5	1.124	169.03	38	8.543	315.82	71	15.961
26.689	6	1.349	173.48	39	8.768	320.27	72	16.186
31.138	7	1.574	177.93	40	8.992	324.72	73	16.411
35.586	8	1.798	182.38	41	9.217	329.17	74	16.636
40.034	9	2.023	186.83	42	9.442	333.62	75	16.861
44.482	10	2.248	191.27	43	9.667	338.06	76	17.085
48.930	11	2.473	195.72	44	9.892	342.51	77	17.310
53.379	12	2.698	200.17	45	10.116	346.96	78	17.535
57.827	13	2.923	204.62	46	10.341	351.41	79	17.760
62.275	14	3.147	209.07	47	10.566	355.86	80	17.985
66.723	15	3.372	213.51	48	10.791	360.31	81	18.210
71.171	16	3.597	217.96	49	11.016	364.75	82	18.434
75.620	17	3.822	222.41	50	11.240	369.20	83	18.659
80.068	18	4.047	226.86	51	11.465	373.65	84	18.884
84.516	19	4.271	231.31	52	11.690	378.10	85	19.109
88.964	20	4.496	235.76	53	11.915	382.55	86	19.334
93.413	21	4.721	240.20	54	12.140	386.99	87	19.558
97.861	22	4.946	244.65	55	12.364	391.44	88	19.783
102.31	23	5.171	249.10	56	12.589	395.89	89	20.008
106.76	24	5.395	253.55	57	12.814	400.34	90	20.233
111.21	25	5.620	258.00	58	13.039	404.79	91	20.458
115.65	26	5.845	262.44	59	13.264	409.24	92	20.682
120.10	27	6.070	266.89	60	13.489	413.68	93	20.907
124.55	28	6.295	271.34	61	13.713	418.13	94	21.132
129.00	29	6.519	275.79	62	13.938	422.58	95	21.357
133.45	30	6.744	280.24	63	14.163	427.03	96	21.582
137.89	31	6.969	284.69	64	14.388	431.48	97	21.806
142.34	32	7.194	289.13	65	14.613	435.93	98	22.031
146.79	33	7.419	293.58	66	14.837	440.37	99	22.256

1N = 0.224809 lbf 1lbf = 4.44822 N

How to use : For example, to convert 20 N into lbf, find the number 20 in the center of the first column. By referring to the lbf column on the right, it will be found that 20 N equals 4.496 lbf.
To convert 20 lbf into N, refer to the N column on the left and it will be found that 20 lbf equals 88.964 N.

N-kgf Conversion Table

N		kgf	N		kgf	N		kgf
9.8066	1	0.1020	333.43	34	3.4670	657.05	67	6.8321
19.613	2	0.2039	343.23	35	3.5690	666.85	68	6.9341
29.420	3	0.3059	353.04	36	3.6710	676.66	69	7.0360
39.227	4	0.4079	362.85	37	3.7729	686.47	70	7.1380
49.033	5	0.5099	372.65	38	3.8749	696.27	71	7.2400
58.840	6	0.6118	382.46	39	3.9769	706.08	72	7.3420
68.647	7	0.7138	392.27	40	4.0789	715.89	73	7.4439
78.453	8	0.8158	402.07	41	4.1808	725.69	74	7.5459
88.260	9	0.9177	411.88	42	4.2828	735.50	75	7.6479
98.066	10	1.0197	421.69	43	4.3848	745.31	76	7.7498
107.87	11	1.1217	431.49	44	4.4868	755.11	77	7.8518
117.68	12	1.2237	441.30	45	4.5887	764.92	78	7.9538
127.49	13	1.3256	451.11	46	4.6907	774.73	79	8.0558
137.29	14	1.4276	460.91	47	4.7927	784.53	80	8.1577
147.10	15	1.5296	470.72	48	4.8946	794.34	81	8.2597
156.91	16	1.6315	480.53	49	4.9966	804.15	82	8.3617
166.71	17	1.7335	490.33	50	5.0986	813.95	83	8.4636
176.52	18	1.8355	500.14	51	5.2006	823.76	84	8.5656
186.33	19	1.9375	509.95	52	5.3025	833.57	85	8.6676
196.13	20	2.0394	519.75	53	5.4045	843.37	86	8.7696
205.94	21	2.1414	529.56	54	5.5065	853.18	87	8.8715
215.75	22	2.2434	539.37	55	5.6084	862.99	88	8.9735
225.55	23	2.3453	549.17	56	5.7104	872.79	89	9.0755
235.36	24	2.4473	558.98	57	5.8124	882.60	90	9.1774
245.17	25	2.5493	568.79	58	5.9144	892.41	91	9.2794
254.97	26	2.6513	578.59	59	6.0163	902.21	92	9.3814
264.78	27	2.7532	588.40	60	6.1183	912.02	93	9.4834
274.59	28	2.8552	598.21	61	6.2203	921.83	94	9.5853
284.39	29	2.9572	608.01	62	6.3222	931.63	95	9.6873
294.20	30	3.0591	617.82	63	6.4242	941.44	96	9.7893
304.01	31	3.1611	627.63	64	6.5262	951.25	97	9.8912
313.81	32	3.2631	637.43	65	6.6282	961.05	98	9.9932
323.62	33	3.3651	647.24	66	6.7301	970.86	99	10.0952

1N = 0.1019716 kgf 1kgf = 9.80665 N

How to use : For example, to convert 20 N into kgf, find the number 20 in the center of the first column. By referring to the kgf column on the right, it will be found that 20 N equals 2.0394 kgf.
To convert 20 kgf into N, refer to the N column on the left and it will be found that 20 kgf equals 196.13 N.

● Temperature Conversion Table

°C			°F			°C			°F			°C			°F		
-73.3	-100	-148.0	-2.2	28	82.4	16.1	61	141.8	34.4	94	201.2	16.1	61	141.8	34.4	94	201.2
-62.2	- 80	-112.0	-1.7	29	84.2	16.7	62	143.6	35.0	95	203.0	16.7	62	143.6	35.0	95	203.0
-51.1	- 60	- 76.0	-1.1	30	86.0	17.2	63	145.4	35.6	96	204.8	17.2	63	145.4	35.6	96	204.8
-40.0	- 40	- 40.0	-0.6	31	87.8	17.8	64	147.2	36.1	97	206.6	17.8	64	147.2	36.1	97	206.6
-28.9	- 20	- 4.0	0	32	89.6	18.3	65	149.0	36.7	98	208.4	18.3	65	149.0	36.7	98	208.4
-17.8	0	32.0	0.6	33	91.4	18.9	66	150.8	37.2	99	210.2	18.9	66	150.8	37.2	99	210.2
-17.2	1	33.8	1.1	34	93.2	19.4	67	152.6	37.8	100	212	19.4	67	152.6	37.8	100	212
-16.7	2	35.6	1.7	35	95.0	20.0	68	154.4	43.3	110	230	20.0	68	154.4	43.3	110	230
-16.1	3	37.4	2.2	36	96.8	20.6	69	156.2	48.9	120	248	20.6	69	156.2	48.9	120	248
-15.6	4	39.2	2.8	37	98.6	21.1	70	158.0	54.4	130	266	21.1	70	158.0	54.4	130	266
-15.0	5	41.0	3.3	38	100.4	21.7	71	159.8	60.0	140	284	21.7	71	159.8	60.0	140	284
-14.4	6	42.8	3.9	39	102.2	22.2	72	161.6	65.6	150	302	22.2	72	161.6	65.6	150	302
-13.9	7	44.6	4.4	40	104.0	22.8	73	163.4	71.1	160	320	22.8	73	163.4	71.1	160	320
-13.3	8	46.4	5.0	41	105.8	23.3	74	165.2	76.7	170	338	23.3	74	165.2	76.7	170	338
-12.8	9	48.2	5.6	42	107.6	23.9	75	167.0	82.2	180	356	23.9	75	167.0	82.2	180	356
-12.2	10	50.0	6.1	43	109.4	24.4	76	168.8	87.8	190	374	24.4	76	168.8	87.8	190	374
-11.7	11	51.8	6.7	44	111.2	25.0	77	170.6	93.3	200	392	25.0	77	170.6	93.3	200	392
-11.1	12	53.6	7.2	45	113.0	25.6	78	172.4	121.1	250	482	25.6	78	172.4	121.1	250	482
-10.6	13	55.4	7.8	46	114.8	26.1	79	174.2	149	300	572	26.1	79	174.2	149	300	572
-10.0	14	57.2	8.3	47	116.6	26.7	80	176.0	177	350	662	26.7	80	176.0	177	350	662
- 9.4	15	59.0	8.9	48	118.4	27.2	81	177.8	204	400	752	27.2	81	177.8	204	400	752
- 8.9	16	60.8	9.4	49	120.2	27.8	82	179.6	232	450	842	27.8	82	179.6	232	450	842
- 8.3	17	62.6	10.0	50	122.0	28.3	83	181.4	260	500	932	28.3	83	181.4	260	500	932
- 7.8	18	64.4	10.6	51	123.8	28.9	84	183.2	288	550	1022	28.9	84	183.2	288	550	1022
- 7.2	19	66.2	11.1	52	125.6	29.4	85	185.0	316	600	1112	29.4	85	185.0	316	600	1112
- 6.7	20	68.0	11.7	53	127.4	30.0	86	186.8	343	650	1202	30.0	86	186.8	343	650	1202
- 6.1	21	69.8	12.2	54	129.2	30.6	87	188.6	371	700	1292	30.6	87	188.6	371	700	1292
- 5.6	22	71.6	12.8	55	131.0	31.1	88	190.4	399	750	1382	31.1	88	190.4	399	750	1382
- 5.0	23	73.4	13.3	56	132.8	31.7	89	192.2	427	800	1472	31.7	89	192.2	427	800	1472
- 4.4	24	75.2	13.9	57	134.6	32.2	90	194.0	454	850	1562	32.2	90	194.0	454	850	1562
- 3.9	25	77.0	14.4	58	136.4	32.8	91	195.8	482	900	1652	32.8	91	195.8	482	900	1652
- 3.3	26	78.8	15.0	59	138.2	33.3	92	197.6	510	950	1742	33.3	92	197.6	510	950	1742
- 2.8	27	80.6	15.6	60	140.0	33.9	93	199.4	538	1000	1832	33.9	93	199.4	538	1000	1832

$$C = \frac{5}{9}(F-32) \quad F = 32 + \frac{9}{5}C$$

How to use : For example, to convert 20°C into °F, find the number 20 in the center of the first column. By referring the °F column on the right, it will be found that 20°C equals 68.0°F.
To convert 20°F into °C, refer to the °C column on the left and it will be found that 20°F equals -6.7°C.

● Grease names and the characteristics (Reference)

Sort	Name	Supplier	Thickener of metallic soap	Consistency	Dropping point (°C)	Service range ⁽¹⁾ (°C)	Remarks
General purpose	ALVANIA GREASE S1	SHELL LUBRICANTS JAPAN	Li	323	182	-35~+120	General, Centralized greasing
	ALVANIA GREASE S2	SHELL LUBRICANTS JAPAN	Li	283	185	-25~+120	General, Centralized greasing
	ALVANIA GREASE S3	SHELL LUBRICANTS JAPAN	Li	242	185	-20~+135	General
	DAPHNE GREASE MP NO.2	IDEMITSU	Li	276	195	-20~+120	General
	COSMO GREASE DYNAMAX No.2	COSMO OIL LUBRICANTS CO., LTD.	Li	280	188	-20~+120	General
Low temperature	MULTINOC GREASE 2	ENEOS	Li	278	212	-30~+125	General
	ALVANIA GREASE RA-J	SHELL LUBRICANTS JAPAN	Li	252	183	-40~+130	Low temperature
	BEACON 325	EMG LUBRICANTS	Li	280	193	-60~+120 ⁽⁺¹⁶⁰⁾	Low temperature, Low torque
	ISOFLEX LDS 18 SPECIAL A	KLÜBER	Li	280	≥185	-60~+130	Low temperature, High speed, Extreme pressure
	ISOFLEX SUPER LDS 18	KLÜBER	Li	280	≥185	-60~+130	Low temperature, High speed, Low noise
Wide temperature range	Unirex N3	EMG LUBRICANTS	Li Complex	235	230	-20~+140 ⁽⁺¹⁹⁰⁾	Wide temperature range, High temperature
	AEROSHELL GREASE 7	SHELL LUBRICANTS JAPAN	Microgel	288	≥260	-73~+149	Wide temperature range, Low temperature
	MULTEMP PS No.2	KYODO YUSHI	Li	275	190	-50~+130	Wide temperature range, For low temperature & low noise
	MULTEMP SRL	KYODO YUSHI	Li	242	192	-50~+150	Wide temperature range, For low temperature & low noise
	MULTINOC WIDE No.2	ENEOS	Li+special Na	247	203	-40~+135	Wide temperature range
Extreme Pressure	ALVANIA EP GREASE 2	SHELL LUBRICANTS JAPAN	Li	276	187	-20~+110	Extreme pressure, Centralized greasing
	MOLYKOTE BR2-PLUS	DuPont Toray Specialty Materials	Li	265	185	-30~+150	With MoS ₂ , Extreme pressure
	Molub-Alloy 777-2 ES	CASTROL	Li	280	180	-30~+120	With MoS ₂ , Extreme pressure
Others	G 40M	SHIN-ETSU	Li	260	≥200	-30~+200	Wide temperature range, Superior at high temperature with stable anti-oxidation and water proof, Chemically inert
	G 40H	SHIN-ETSU	Li	220	≥200	-30~+200	Wide temperature range, Superior at high temperature with stable anti-oxidation and water proof, Chemically inert
	KRYTOX 240AD	CHEMOURS	Fluorinated	275	None	-30~+288	Stabl at high temperature, Chemically inert, Anti-solvent
	BARRIERTA L55/2	KLÜBER	Fluorinated	No.2	None	-35~+220 ⁽⁺²⁵⁰⁾	General, Low evaporation at high temperature, Chemically inert
	BARRIERTA IMI/V	KLÜBER	Fluorinated	No.2	None	-50~+220	For high vacuum
	DOLIUM GREASE R	SHELL LUBRICANTS JAPAN	Polyurea	281	249	-30~+150	Heat resistant, Superior at high temperature with stable anti-oxidation
	STAMINA GREASE RL2	SHELL LUBRICANTS JAPAN	Polyurea	268	271	-20~+180	Heat resistant, Superior at high temperature with stable anti-oxidation

Note⁽¹⁾ : Figures in parentheses show the maximum allowable temperature in very short time operation, and they are not applicable for continuous operation.

Remark When using these products, see individual manufacturer's catalogs.

IKO Linear Motion Rolling Guide Series,

Configuration of General Catalog

IKO Linear Motion Rolling Guide Series General Catalog Consists of **BLUE** (CAT-1600E) and

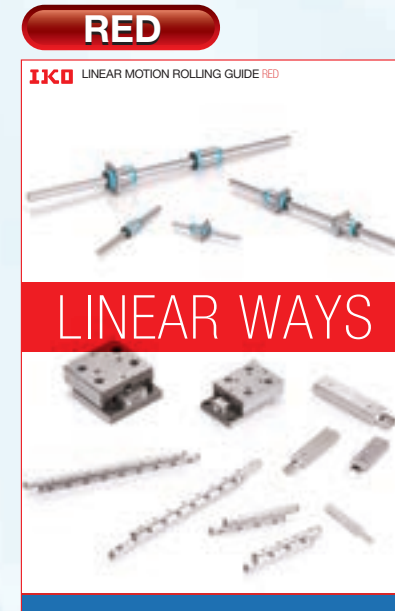
RED (CAT-1601E), the two volumes.



CAT-1600E

[Models]

- Rail Guide Type
Endless Linear Motion Type



CAT-1601E

[Models]

- Rail Guide Type
Limited Linear Motion Type
- Shaft Guide Type
Endless Linear Motion Type
Limited Linear Motion Type + Rolling Motion Type
- Flat Guide Type
Endless Linear Motion Type
Limited Linear Motion Type

C-Lube Linear Way ML C-Lube Linear Way MLV C-Lube Linear Way MV C-Lube Linear Way ME Linear Way E C-Lube Linear Way MH Linear Way H



Linear Way F C-Lube Linear Way MUL Linear Roller Way Super MX Linear Roller Way X Linear Way Module



Rail Guide Type Crossed Roller Way Rail Guide Type Linear Slide Unit Shaft Guide Type Linear Ball Spline Shaft Guide Type Linear Bushing



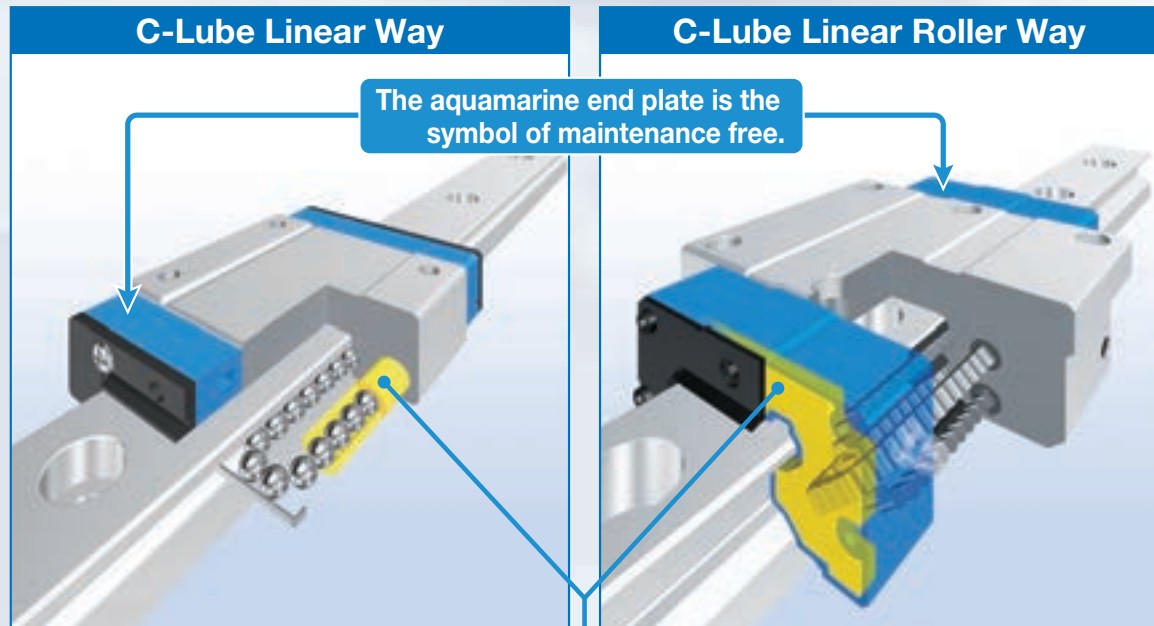
Shaft Guide Type Stroke Rotary Bushing Flat Guide Type Roller Way & Flat Roller Cage





Features of C-Lube Linear Way and C-Lube Linear Roller Way

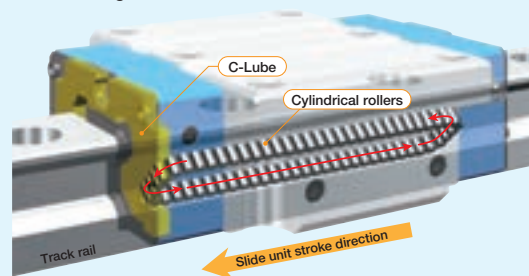
Original and world's first structure with [C-Lube]



C-Lube integrated

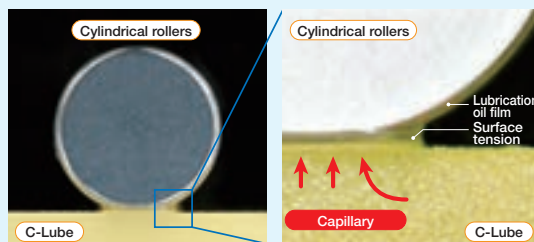
Lubrication oil is carried through circulation of rolling elements

The lubrication oil is supplied directly to the rolling elements, not to the track rail. When rolling elements make contact with the capillary lubricating element integrated with the circulation path of slide unit rolling elements, the lubrication oil is supplied to surfaces of rolling elements and carried to the loading area through circulation of rolling elements. This results in adequate lubrication oil being properly maintained in the loading area and lubrication performance will last for a long time.



Lubrication oil is directly supplied to surfaces of the rolling elements

The surface of capillary lubricating element is always covered with the lubrication oil. Lubrication oil is continuously supplied to the surface of rolling elements by surface tension in the contact of capillary lubricating element surface and rolling elements. On the surface of capillary lubricating element with which the rolling elements make contact, new lubrication oil is always supplied from the other sections.



Long term maintenance free is realized with oil impregnated with C-Lube only !!



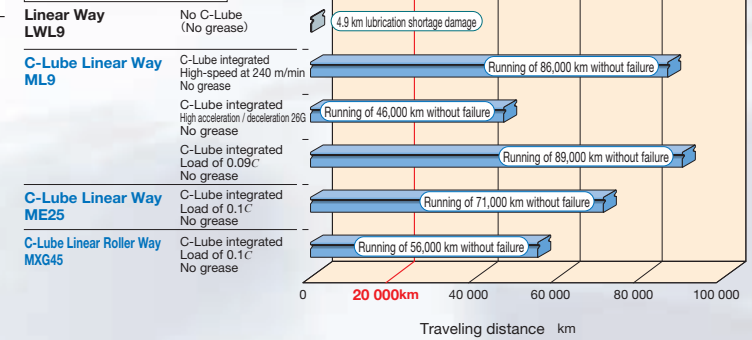
Maintenance free

This endures running over 20,000 km without oil feeding with lubrication oil in the C-Lube only. Furthermore, grease is pre-packed in the slide unit so long term maintenance free can be realized.

Maintenance free is achieved until the end of device life!

*1. Typical device life is assumed. Re-greasing may be necessary depending on use conditions.

Durability test result

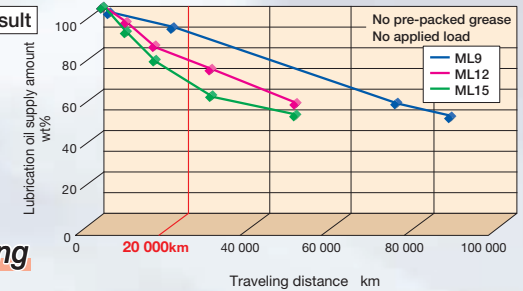


Eco-friendly

As lubrication oil in C-Lube is supplied by the amount necessary to maintain lubrication performance of the rolling guide, the consumption of lubrication oil is reduced and lubrication performance is maintained even when it run for a long period.

Eco-friendly specification reducing usage of lubrication oil!

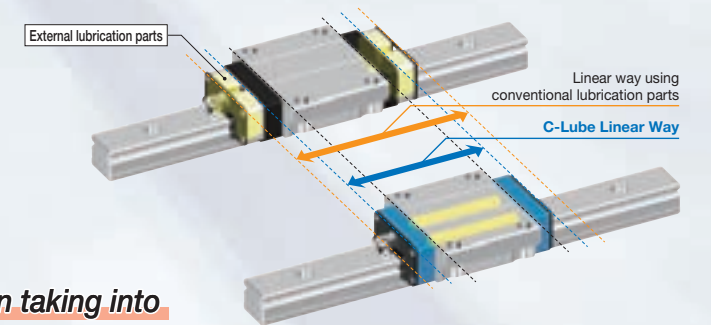
Oil supply test result



Compact

As C-Lube Linear Way and C-Lube Linear Roller Way are integrated with lubrication part C-Lube, their slide units are not long unlike types with external lubrication parts. Replacement of conventional parts is easy free from constraints of mounting space and stroke length.

Compact design taking into account compactness!

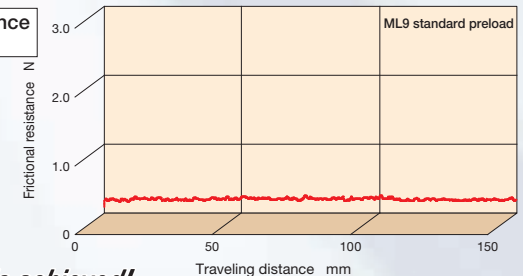


Smooth

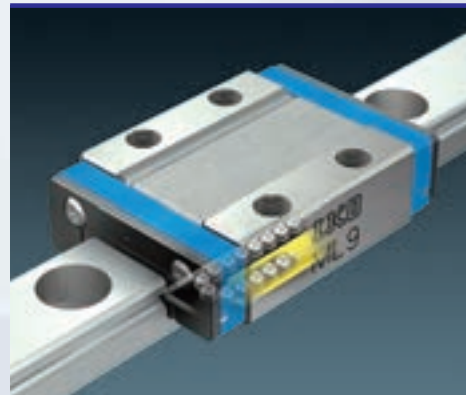
C-Lube Linear Way and C-Lube Linear Roller Way do not generate slide resistance unlike lubrication parts external to the slide unit that make contact with the track rail. Driving force follow-up property is superior and energy is saved by improvement of accuracy and reduction of friction loss.

Light and smooth motion is achieved!

Frictional resistance test result



A variety of models and size variations



Ball Type Miniature Series

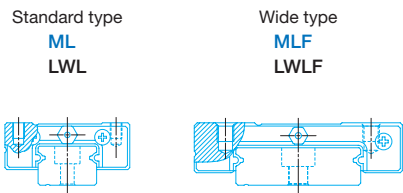
C-Lube Linear Way ML C-Lube Linear Way MLV Linear Way L

Thanks to the structure with two rows of balls to contact with the way at four points, stable accuracy and rigidity can be achieved even in applications where load has variable direction and size or complex load is applied, despite its very small body.

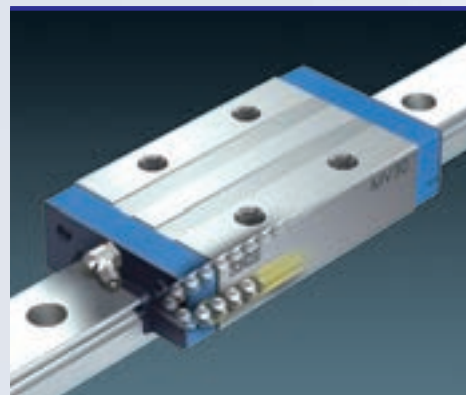


Micro Linear Way L

As the lineup of track rail width from 1 mm to 6 mm is available, you can select an optimal product for the specifications of your machine and device. For LWL1, world's smallest size is realized: track rail width of 1 mm, slide unit width of 4 mm and assembly height of 2.5 mm.



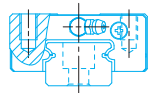
Length of slide unit		Size	
C	Short	Standard type	1, 2, 3, 5, 7, 9, 12, 15, 20, 25
No symbol	Standard	Wide type	4, 6, 10, 14, 18, 24, 30, 42
G	Long		
L	Extra long		



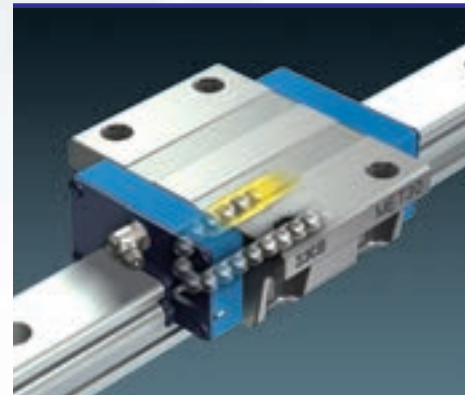
Ball Type Low Profile/Light Weight Series

C-Lube Linear Way MV

Despite its extra low profile and extra light weight, this linear motion rolling guide has the maximum load rating among the ball types while achieving high load capacity.



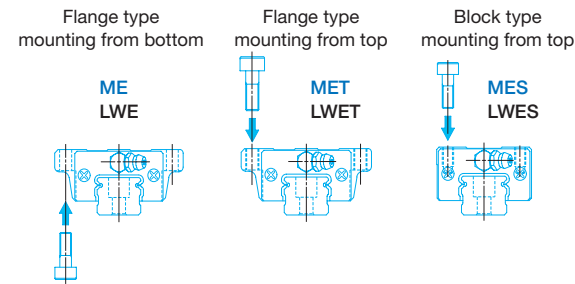
Length of slide unit		Size	
Standard			20, 25, 30



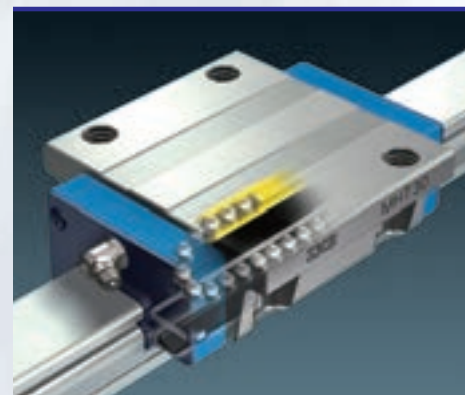
Ball Type Compact Series

C-Lube Linear Way ME Linear Way E Low Decibel Linear Way E

Versatile linear motion rolling guide that has achieved utility pursuing compactness in every aspect. Low decibel types with resin separator to prevent direct contact between balls are also available.



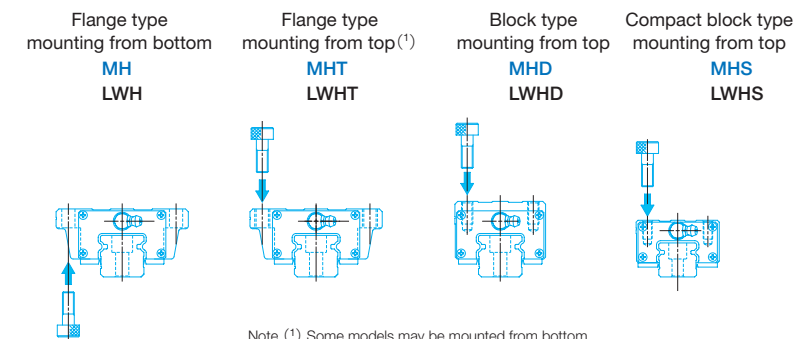
Length of slide unit		Size	
C	Short	15, 20, 25, 30, 35, 45	
No symbol	Standard		
G	Long		



Ball Type High Rigidity Series

C-Lube Linear Way MH Linear Way H

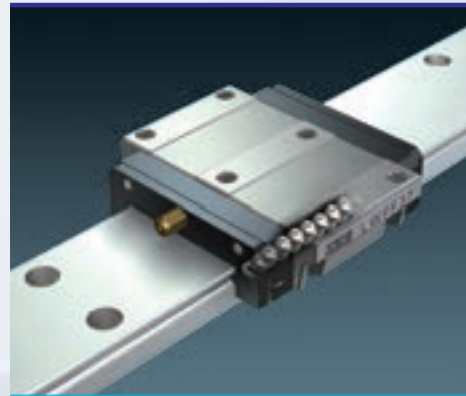
High rigidity linear motion rolling guides designed to evenly support high load capacity by incorporating large-diameter balls. Stable accuracy and rigidity can be achieved even in applications where load with variable direction and size and complex load are applied.



Note (1) Some models may be mounted from bottom.

Length of slide unit		Size	
C	Short	8, 10, 12, 15, 20, 25, 30, 35, 45, 55, 65	
No symbol	Standard		
G	Long		
L	Extra long		

A variety of models and size variations

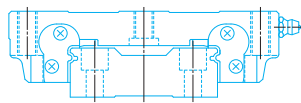


Ball Type Wide Type Series

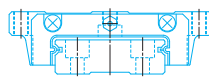
Linear Way F

As wide track rail is used and the distance between the load points is long, this is a linear motion rolling guide suitable to single-row use due to the structure resistant to across-the-width moment load. It is also resistant to complex load.

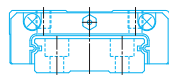
Flange type mounting from top / bottom
LWFH



Flange type mounting from top / bottom
LWFF



Block type mounting from top
LWFS



Length of slide unit	
No symbol	Standard
Size	
LWFH	40,60,90
LWFF	33,37,42,69
LWFS	33,37,42

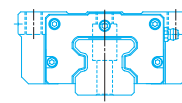


Roller Type

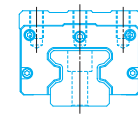
C-Lube Linear Roller Way Super MX
Linear Roller Way Super X

Linear motion rolling guide that has achieved the highest level of performance in all characteristics utilizing the roller's superior characteristic, such as rigidity, load capacity, running accuracy and vibration damping property. With extra long unit with the maximum slide unit length, load capacity and rigidity are improved and running performance with super high accuracy is realized.

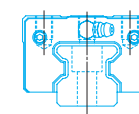
Flange type mounting from top / bottom
MX^(*)
LRX^(*)



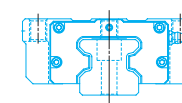
Block type mounting from top
MXD
LRXD



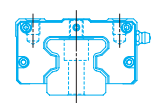
Compact block type mounting from top
MXS
LRXS



Low profile flange type mounting from top
MXN

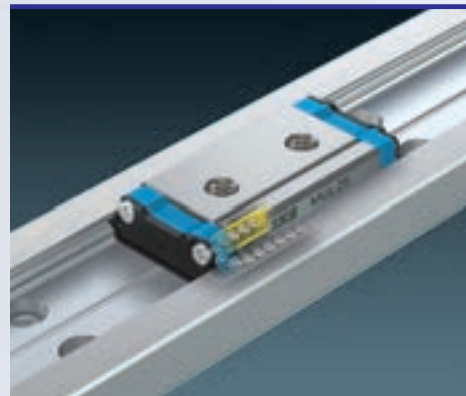


Low profile block type mounting from top
MXNS



Note (*) Size 20 series allows only for mounting from top and model mounting from bottom is MXH and LRXH.

Length of slide unit				Size
C	No symbol	G	L	10, 12, 15, 20, 25, 30, 35, 45, 55, 65, 85, 100
Short	Standard	Long	Extra long	

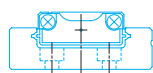


Ball Type U-Shaped Track Rail Series

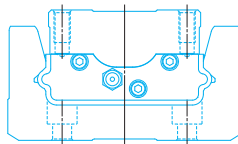
C-Lube Linear Way MUL
Linear Way U

Linear motion rolling guide of the structure with way inside the track rail of U-shaped section and slide unit therein. With the U-shaped track rail, rigidity against the track rail moment load and torsion is significantly improved.

Small type
MUL
LWUL



Standard type
LWU



Length of slide unit	
No symbol	Standard
Size	
MUL	25, 30
LWUL	25, 30
LWU	40, 50, 60, 86, 100, 130

Four-row roller guide of world's smallest size
Track rail width of 10 mm

Super high rigidity
Super high load capacity
High running performance
Excellent frictional characteristics

Stainless steel made
LRXD10...SL

Mechatronics Series

TU Series

IKO Precision Positioning Table TU is a compact and slim positioning table with good load balance and high resistance to complex loads, in which the side table is arranged inside the U-shape track rail. Six types with a track rail width of 25 ~ 130mm are available. Each slide table length can be selected as required. Different table specifications including ball screw, motor, sensor, etc. can be selected. This allows each user to configure the most suitable positioning table for each application.

Abundant options meet diversified market needs such as a motor loopback specification, table with bellows, table with bridge cover, and table finished by black chrome surface treatment.

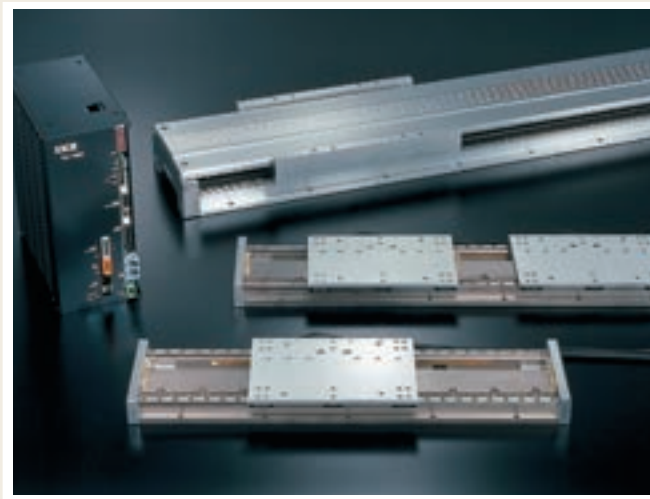


Linear Motor Table LT

The IKO Linear Motor Table LT is a compact and lightweight direct-drive positioning table with a very small sectional height in which an AC servo-motor and an optional linear scale are integrated in a moving table and a bed made of aluminum alloy.

The IKO Linear Motor Table LT employs a C-shaped magnet yoke, and a coil board is sandwiched between two stator magnets. It provides a high thrust of 450N though its height is only 40 mm. The moving table is as light as 1.5 kg but provides high thrust. It permits high acceleration and deceleration exceeding 10 G. (In the case of LT150 CG.) Also, High Thrust Series LT...H outputs 900N thrust.

Using advanced servo technology, this product achieves high static stability and high-speed stability.



Long-stroke Series

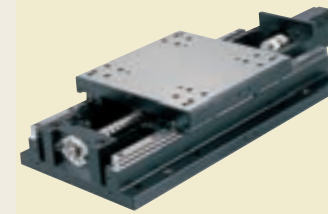
- Standard type which has been practically used in many fields.
- Stable characteristics in parallel use together with Linear Way



TSL...M

High-rigidity Series

- High reliability and high accuracy with component parts strictly selected
- High rigidity and large mounting weight



TSLH...M · CTLH...M

Super Precision Series

- XY configuration available for advanced inspection stage
- High positioning accuracy realized with IKO Roller technology and full closed loop controlling



TX...M CTX...M

Compact Series

- Compact structure with a small sectional height
- High reliability and high accuracy achieved by using Crossed Roller Way



TS · CT

High-speed Long Stroke Series

- High-speed type using a timing belt drive
- Stable and high traveling performance in parallel use together with Linear Way



TSLB

Precision Positioning Table

- Light weight precision positioning table made of high-strength aluminum alloy.
- Built-in C-Lube for long-term maintenance-free service.



TE...B

Micro Precision Positioning Table

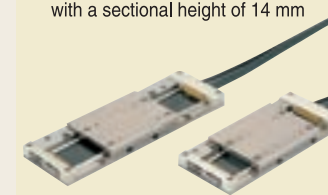
- Very compact positioning table that is 20mm high(sectional) and 17mm wide driven by a ground ball screw.
- +/-0.5micron repeatability is achieved with 60 mm stroke length.



TM

Nano Linear

- Direct drive type with high speed and high response
- Maximum thrust of 25 N achieved with a sectional height of 14 mm



NT...V

Alignment Stage Direct Drive

- Ultra compact XY θ stage contributing to space saving
- High resolution and response realized with optical scale

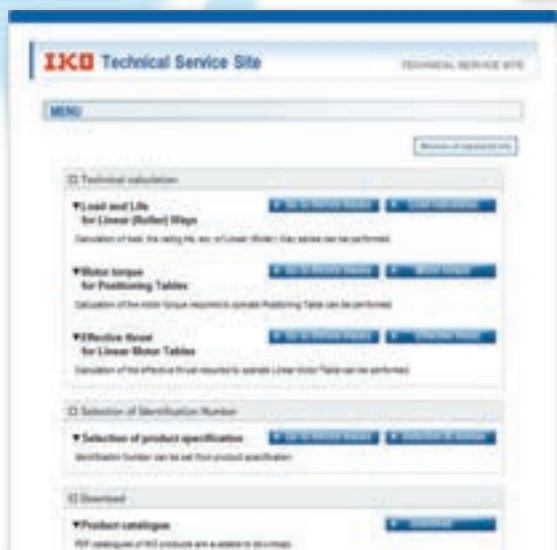


SA...DE

IKO Introduction of Technical Service Site

"IKO Technical Service Site" can be accessed from our home page. The site provides various tools for selecting Linear Ways and Linear Roller Ways. Please utilize these tools for assistance when selecting products. Additionally the site also provides CAD data and product catalogs for the Needle Series, Linear Motion Rolling Guide Series, and Mechatronics Series for download. Please utilize them to improve your design efficiency.

<https://www.ikont.co.jp/eg/>



1. Technical calculations

For Linear Way/Linear Roller Way load and life calculation, you can obtain the calculated load and the rating life by entering the operating conditions.

Also you can derive the motor torque required for operation and the effective thrust force during operation in the sections of motor torque calculation and calculation of effective thrust force of linear motor tables respectively, and output the calculation results in PDF format, as well as save the histories.



2. Selection of Identification Number

By selecting such specification as model code, dimensions, part code, material code, preload symbol, classification symbol, interchangeable code and supplemental code of Linear ways/Linear roller ways, you can easily specify the identification number used for ordering.

Also you can browse the CAD data of the selected products, calculate the load, and output the selection results in PDF format, as well as save the histories.



3. Downloading CAD data

2-dimensional CAD data (DXF file)

There are two types of figures, brief figure and detailed figure. The brief figure shows only the external view lines, and the detailed figure shows the detailed lines. The drawing consists of three drawings: front view, side view and plain view. The scale shows only the original size (1:1), and it does not show dimension lines.



3-dimensional CAD data

It is linked to the mechanical parts CAD library "PART community". Entering the rail dimension and option contents to the detail, you can view the 2D/3D CAD data suitable for the specification for free of charge.



4. Downloading Catalog and Operation Manual

You can download product catalogs of needle series, linear motion rolling guide series and mechatronics series, operation manuals of precision positioning tables and various electrical components in PDF format, as well as support software for precision positioning tables. If you would like a copy of our catalog, please visit the IKO official website and apply for the catalog, or contact our regional office or sales office nearby.

Index of Model Codes

GE··GS	K19	Spherical Bushings	NAG 49	E7	Roller Bearings
GE··GS-2RS	K19	Spherical Bushings	NAG 49··UU	E13	Roller Bearings
GS	F7	Thrust Bearings	NART··FR	I99	Roller Followers
GTR	D9	Machined Type Needle Roller Bearings	NART··FUUR	I99	Roller Followers
GTRI	D31	Machined Type Needle Roller Bearings	NART··R	I95	Roller Followers
I					
IRB	H10	Inner Rings	NART··UUR	I95	Roller Followers
IRT	H5	Inner Rings	NART··UUR/SG	I101	C-Lube Roller Followers
K					
KT	C5	Needle Roller Cages for General Usage	NART··VR	I95	Roller Followers
KT··EG	C21	Needle Roller Cages for Engine Connecting Rods	NART··VUUR	I95	Roller Followers
KTV··EG	C22	Needle Roller Cages for Engine Connecting Rods	NAS 50··UUNR	E19	Roller Bearings
KTW	C9	Needle Roller Cages for General Usage	NAS 50··ZZNR	E19	Roller Bearings
L					
LHS	K51	L-Balls	NAST	I92	Roller Followers
LHSA	K49	L-Balls	NAST··R	I92	Roller Followers
LRB	H25	Inner Rings	NAST··ZZ	I93	Roller Followers
LRBZ··B	H25	Inner Rings	NAST··ZZR	I93	Roller Followers
LRT	H13	Inner Rings	NAST··ZZUU	I93	Roller Followers
LRTZ	H13	Inner Rings	NAST··ZZUUR	I93	Roller Followers
N					
NA 48	D41	Machined Type Needle Roller Bearings	NATA 59	G9	Combined Type Needle Roller Bearings
NA 49	D29	Machined Type Needle Roller Bearings	NATB 59	G9	Combined Type Needle Roller Bearings
NA 49··UU	D61	Machined Type Needle Roller Bearings	NAU 49	E7	Roller Bearings
NA 69	D29	Machined Type Needle Roller Bearings	NAU 49··UU	E13	Roller Bearings
NA 69··UU	D61	Machined Type Needle Roller Bearings	NAX	G5	Combined Type Needle Roller Bearings
NAF	D89	Needle Roller Bearings with Separable Cage	NAX··Z	G5	Combined Type Needle Roller Bearings
NAFW	D89	Needle Roller Bearings with Separable Cage	NAXI	G7	Combined Type Needle Roller Bearings
			NAXI··Z	G7	Combined Type Needle Roller Bearings
			NBX	G5	Combined Type Needle Roller Bearings
			NBX··Z	G5	Combined Type Needle Roller Bearings
			NBXI	G7	Combined Type Needle Roller Bearings
			NBXI··Z	G7	Combined Type Needle Roller Bearings
			NTB	F7	Thrust Needle bearings
			NUCF··BR	I67	Cam Followers
			NURT	I103	Roller Followers
			NURT··R	I103	Roller Followers

Index of Model Codes

O					
OS	L3	Seals for Needle Roller Bearings	SNM	K59	Super Flexible Nozzle
P					
PB	K37	PILLOBALLs	SNPT	K59	Super Flexible Nozzle
PHS	K38	PILLOBALLs	T		
PHS··EC	K43	PILLOBALLs	TA··Z	B7	Shell Type Needle Roller Bearings
PHSA	K42	PILLOBALLs	TAF	D7	Machined Type Needle Roller Bearings
PHSB	K40	PILLOBALLs	TAF··/SG	D77	C-Lube Machined Type Needle Roller Bearings
POS	K39	PILLOBALLs	TAFI	D29	Machined Type Needle Roller Bearings
POSB	K41	PILLOBALLs	TAM	B7	Shell Type Needle Roller Bearings
POS··EC	K44	PILLOBALLs	TAMW	B21	Shell Type Needle Roller Bearings
PRC	K53	PILLOBALLs	TAW··Z	B21	Shell Type Needle Roller Bearings
R					
RNA 48	D23	Machined Type Needle Roller Bearings	TLA··UU	B49	Shell Type Needle Roller Bearings
RNA 49	D7	Machined Type Needle Roller Bearings	TLA··Z	B7	Shell Type Needle Roller Bearings
RNA 49··UU	D55	Machined Type Needle Roller Bearings	TLAM	B7	Shell Type Needle Roller Bearings
RNA 69	D9	Machined Type Needle Roller Bearings	TLAMW	B17	Shell Type Needle Roller Bearings
RNA 69··UU	D55	Machined Type Needle Roller Bearings	TLAW··Z	B17	Shell Type Needle Roller Bearings
RNAF	D83	Needle Roller Bearings with Separable Cage	TR	D9	Machined Type Needle Roller Bearings
RNAFW	D83	Needle Roller Bearings with Separable Cage	TRI	D31	Machined Type Needle Roller Bearings
RNAST	I91	Roller Followers	TRU	E7	Roller Bearings
RNAST··R	I91	Roller Followers	TRU··UU	E13	Roller Bearings
S					
SB	K11	Spherical Bushings	W		
SB··A	K11	Spherical Bushings	WR	L19	Cir-clips for Needle Roller Bearings
SBB	K23	Spherical Bushings	WS	F7	Thrust Bearings
SBB··-2RS	K23	Spherical Bushings	Y		
SNA	K58	Super Flexible Nozzle	YB	B27	Shell Type Needle Roller Bearings
			YBH	B29	Shell Type Needle Roller Bearings
			YT	B7	Shell Type Needle Roller Bearings
			YTL	B7	Shell Type Needle Roller Bearings

Oil Minimum

IKO Gentle to The Earth

Nippon Thompson Co., Ltd. is working to develop global environment-friendly products.

It is committed to developing products that make its customers' machinery and equipment more reliable, thereby contributing to preserving the global environment.

This development stance manifests well in the keyword "Oil Minimum."

Our pursuit of Oil Minimum has led to the creation of IKO's proprietary family of lubricating parts as "C-Lube."

IKO Products Underpin Sustain Technology Leaps

Nippon Thompson Co., Ltd. was the first Japanese manufacturer to develop needle bearings on its own and has since expanded into the arena of linear motion rolling guides (Linear Motion Series and Mechatro Series) on the support of its advanced expertise. The company now offers a vast assortment of ingenious products, including the world's first C-Lube Maintenance-Free Series, to address increasingly diversified customer needs and thus sustain technology leaps.

C-Lube Maintenance-Free Series Products Evolving from the "Oil Minimum" Concept

We have developed lubricating parts impregnated with a large amount of lubricant as C-Lube Series to save the customer's oiling management workload and built them into bearings and linear motion rolling guides.

The C-Lube Series not only keeps products maintenance-free for long by giving them an optimal and minimal amount of a lubricant for an extended period of time but also contributes greatly to preserving the global environment.



Needle Roller Bearings

Needle Bearings

Machine elements essential to any industry



Linear Motion Rolling Guide Series

Linear Motion Rolling Guides/Linear Motion Series

Available in broad sizes, from minimum to extra-large



Mechatronics Series

Linear Motion Rolling Guides/Mechatro Series

A merger of precision machining expertise and electronics

- IKO Linear Motion Rolling Guides are manufactured through a control system that alleviates their impact on the global environment to meet the quality requirements of ISO 14001 in compliance with the quality requirements level of ISO 9001 for quality improvement.
- The standard products listed in this catalog comply with the specifications of the ten hazardous materials cited in the European RoHS Directive.

● Although all data in this catalog has been carefully compiled to make the information as complete as possible, NIPPON THOMPSON CO., LTD. shall not be liable for any damage whatsoever, direct or indirect, based on on any of the information contained in this catalog.
NIPPON THOMPSON CO., LTD. makes no warranty, either express or implied, including the implied warranty of merchantability or fitness for a particular purpose.

NIPPON THOMPSON CO., LTD.

CAT-1603E ©All rights reserved AKA

Printed in China 2024.07

SERVICE NETWORK OF IKO PRODUCTS

NIPPON THOMPSON CO., LTD. (JAPAN)

Head Office : 19-19, Takanawa 2-chome, Minato-ku,
Tokyo, 108-8586, Japan 
Phone : +81 (0)3-3448-5850
Fax : +81 (0)3-3447-7637
E-mail : ntt@ikonet.co.jp
URL : https://www.ikonet.co.jp/eg/
Plant : Gifu, Kamakura

IKO THOMPSON KOREA CO., LTD. (KOREA)

201, Worldvision Bldg., 77-1, Yeouinaru-ro,
Yeongdeungpo-gu, Seoul, Korea
Phone : +82 (0)2-6337-5851
Fax : +82 (0)2-6337-5852
E-mail : itk@ikonet.co.jp

IKO THOMPSON ASIA CO., LTD. (THAILAND)

Unit 305,3rd Fl., Zuellig house, 1-7 Silom Rd.,
Silom Bangrak, Bangkok 10500, Thailand
Phone : +66 (0)2637-5115
Fax : +66 (0)2637-5116
E-mail : ita@ikonet.co.jp

Recognizing that conservation of the global environment is the top-priority challenge for the world's population, Nippon Thompson will conduct its activities with consideration of the environment as a corporate social responsibility, reduce its negative impact on the environment, and help foster a rich global environment.

**ISO 9001 & 14001 Quality system
registration certificate**



- The specifications and dimensions of products in this catalog are subject to change without prior notice.
- When these products are exported, the exporter should confirm a forwarding country and a use, and, in case of falling under the customer's requirements, take necessary procedures such as export permission application.
- Although all data in this catalog has been carefully compiled to make the information as complete as possible, NIPPON THOMPSON CO., LTD. shall not be liable for any damages whatsoever, direct or indirect, based upon any information in this catalog. NIPPON THOMPSON CO., LTD. makes no warranty, either express or implied, including the implied warranty of merchantability or fitness for a particular purpose.
- Reproduction and conversion without permission are prohibited.

IKO-THOMPSON (SHANGHAI) LTD. (CHINA)

Shanghai (Sales Head Office)

2301-02, 2310, MetroPlaza No.555,
LouShanGuan Road, ChangNing District,
Shanghai, People's Republic of China, 200051
Phone : +86 (0)21-3250-5525
Fax : +86 (0)21-3250-5526
E-mail : ntc@ikonet.co.jp

Beijing Branch

Room 1909, Tower C Oriental Media Center,
Guanghua Road No. 4 Chaoyang District, Beijing,
People's Republic of China, 100026
Phone : +86 (0)10-6515-7681
Fax : +86 (0)10-6515-7689
E-mail : ntc@ikonet.co.jp

Guangzhou Branch

Room 834, Garden Tower, Garden Hotel
368 Huanshi East Road, Yuexiu District, Guangzhou,
Guangdong
People's Republic of China, 510064
Phone : +86 (0)20-8384-0797
Fax : +86 (0)20-8381-2863
E-mail : ntc@ikonet.co.jp

Wuhan Branch

Room 2300, Truro Plaza No.72, Wusheng Road,
Qiao kou District, Wuhan, Hubei,
People's Republic of China, 430033
Phone : +86 (0)27-8556-1610
Fax : +86 (0)27-8556-1630
E-mail : ntc@ikonet.co.jp

Shenzhen Branch

Room1808, KEENSTAR Building 18,
Chuangye 2nd Rd 248, Bao'an, Shenzhen, Guangdong,
People's Republic of China, 518081
Phone : +86 (0)755-2265-0553
Fax : +86 (0)755-2298-0665
E-mail : ntc@ikonet.co.jp

Xian Branch

Room 2010, Block B, Chaoyang International Plaza,
No. 166,
Changle West Road, Xincheng District Xi'an, Shanxi,
People's Republic of China, 710032
Phone : +86 (0)29-8323-5915
E-mail : ntc@ikonet.co.jp

Qingdao Branch

Room 608, Building 47, Huarun City,
No. 101 Shenzhen Road, Laoshan District,
Qingdao City, Shandong
People's Republic of China, 266100
Phone : +86 (0)532-8670-2246
Fax : +86 (0)532-8670-2242
E-mail : ntc@ikonet.co.jp

Shenyang Branch

2-1203 Tower I, City Plaza Shenyang NO.206,
Nanjing North Street, Heping District,
Shenyang, Liaoning
People's Republic of China, 110001
Phone : +86 (0)24-2334-2662
Fax : +86 (0)24-2334-2442
E-mail : ntc@ikonet.co.jp

Ningbo Office

Room 3406, Zhongnongxin Building, No.181,
Zhongshan East Road, Haishu District,
Ningbo, Zhejiang
People's Republic of China, 315000
Phone : +86 (0)574-8718-9535
Fax : +86 (0)574-8718-9533
E-mail : ntc@ikonet.co.jp

IKO INTERNATIONAL, INC. (U.S.A.)

East Coast Operation (Sales Head Office)

91 Walsh Drive,
Parsippany, NJ, 07054,
U.S.A. 
Phone : +1-973-402-0254
Toll Free : +1-800-922-0337
Fax : +1-973-402-0441
E-mail : eco@ikonet.co.jp

Midwest Operation

101 Mark Street, Unit-G,
Wood Dale, IL, 60191,
U.S.A.
Phone : +1-630-766-6464
Toll Free : +1-800-323-6694
Fax : +1-630-766-6869
E-mail : mwo@ikonet.co.jp

West Coast Operation

9830 Norwalk Boulevard, Suite 198,
Santa Fe Springs, CA, 90670,
U.S.A.
Phone : +1-562-941-1019
Toll Free : +1-800-252-3665
Fax : +1-562-941-4027
E-mail : wco@ikonet.co.jp

Silicon Valley Sales Office

1500 Wyatt Drive, Suite 10,
Santa Clara, CA, 95054,
U.S.A.
Phone : +1-408-492-0240
Toll Free : +1-800-252-3665
Fax : +1-408-492-0245
E-mail : wco@ikonet.co.jp

Southeast Operation

3235 Satellite Boulevard Building 400, Suite 230,
Duluth, GA, 30096,
U.S.A.
Phone : +1-770-418-1904
Toll Free : +1-800-874-6445
Fax : +1-770-418-9403
E-mail : seo@ikonet.co.jp

Southwest Operation

6191 N STATE HIGHWAY 161, STE 440,
IRVING, TX 75038-2264,
U.S.A.
Phone : +1-972-925-0444
Toll Free : +1-800-295-7886
Fax : +1-972-707-0385
E-mail : swo@ikonet.co.jp

IKO THOMPSON BEARINGS CANADA, INC. (CANADA)

731-2425, Matheson Boulevard East, 7th floor,
Mississauga, Ontario, L4W 5K4, Canada
Phone : +1-647-931-3933
E-mail : itc@ikonet.co.jp

NIPPON THOMPSON EUROPE B.V. (EUROPE)

The Netherlands (Sales Head Office)

Keersopstraat 35,
3044 EX, Rotterdam,
The Netherlands 
Phone : +31 (0)10-462 68 68
E-mail : nte@ikonet.co.jp

Germany Branch

Mündelheimer Weg 54,
40472 Düsseldorf,
Germany
Phone : +49 (0)211-41 40 61
Fax : +49 (0)211-42 76 93
E-mail : ntd@ikonet.co.jp

Regensburg Sales Office

Im Gewerbepark D 04,
93059 Regensburg,
Germany
Phone : +49 (0)941-20 60 70
Fax : +49 (0)941-20 60 719
E-mail : ntdr@iko-nt.de

U.K. Branch

2 Vincent Avenue, Crownhill,
Milton Keynes, Bucks, MK8 0AB,
United Kingdom
Phone : +44 (0)1908-566144
E-mail : sales@iko.co.uk

Spain Branch

Autovia Madrid-Barcelona, Km. 43,700
Polig. Ind. AIDA - Nove A-8, Ofic. 2-1ª
19200-Azuqueca de Henares,
(Guadalajara) Spain
Phone : +34 949-26 33 90
Fax : +34 949-26 31 13
E-mail : nts@ikonet.co.jp

France Branch

Bâtiment le Raphaël-Paris, Nord 2,
22 avenue des Nations
BP54394 Villepinte
95943 ROISSY C.D.G Cedex
France
Phone : +33 (0)1-48 16 57 39
Fax : +33 (0)1-48 16 57 46
E-mail : ntf@ikonet.eu

IKO BRASIL SERVIÇOS EMPRESARIAIS LTDA. (BRAZIL)

Rua Frei Caneca 1407,
Condominio Edificio Barão de Monte Cedro,
Cjs. 801/802, Consolação, São Paulo- SP
Cep: 01307-909
Phone : +55 (0)11-2366-3033
E-mail : itb@ikonet.co.jp