

## Linear Bushing

**Linear Bushing G**

**Linear Bushing**

**Miniature Linear Bushing**



# Linear Bushing G

# LMG



## Points

### 1 High load capacity

The structure that balls in two rows have contact with the track groove of the shaft allows greater rigidity and larger load capacity.

### 2 Solid shaft and hollow shaft

There are two types of shafts with grooved raceway: a solid shaft and a hollow shaft. The hollow shaft is useful for piping, wiring, air removal, etc.

### 3 Dimensionally compatible with Linear Bushing LM

LMG series are dimensionally compatible with Linear Bushing LM to allow easy replacement.

## Identification Number and Specification

### Example of an identification number

The specification of LMG series is indicated by the identification number. Indicate the identification number, consisting of a model code, dimensions, a part code, and a supplemental code for each specification to apply.

Interchangeable specification	1	2	3	4	5	6
Single external cylinder	LMG		10	C1		/U
Single shaft with grooved raceway	LMG	T	10		R300	
Assembled set	LMG	T	10	C1	R300	/U

- 1 Model Model code Page II - 135
- 2 Shape of shaft with grooved raceway Part code Page II - 135
- 3 Size Dimensions Page II - 135
- 4 Number of external cylinders Part code Page II - 135
- 5 Length of shaft with grooved raceway Part code Page II - 135
- 6 Special specification Supplemental code Page II - 135

# Identification Number and Specification – Model · Shape of Shaft · Size · Number of External Cylinders · Length of Shaft · Special Specification –

<b>1 Model</b>	Linear Bushing G (LMG series) : LMG For applicable models and sizes, see Table 1.
<b>2 Shape of shaft with grooved raceway</b>	Solid shaft : No symbol For applicable models and sizes, see Table 1. Hollow shaft : T
<b>3 Size</b>	6, 8, 10, 13, 16, 20 Indicate the shaft diameter in mm. For applicable models and sizes, see Table 1.

**Table 1 Models and sizes of LMG series**

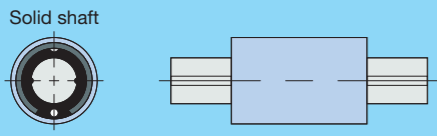
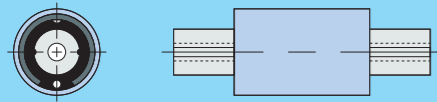
Shape	Model	Size					
		6	8	10	13	16	20
Solid shaft 	LMG	○	○	○	○	○	○
Hollow shaft 	LMGT	○	○	○	○	○	○

Remark: LMG series are all interchangeable specification. Non-interchangeable specification is not available.

<b>4 Number of external cylinders</b>	: ○○ For an assembled set, indicates the number of external cylinders assembled on a shaft with grooved raceway. For a single external cylinder, only "C1" is specified.
<b>5 Length of shaft with grooved raceway</b>	: R○ Indicate the length of the shaft with grooved raceway in mm. For standard and maximum lengths, see the dimension table.
<b>6 Special specification</b>	With end seal /U Applicable to all models and sizes.

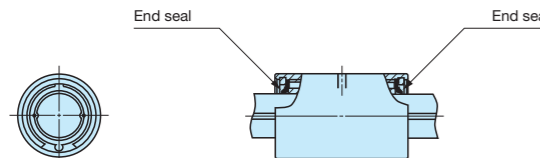
<b>With end seal /U</b>		End seals are attached to both ends of the external cylinder to prevent foreign substances from entering.
-------------------------	---	---

# Accuracy

**Table 2 Twist of grooves with respect to effective length of track groove**

Allowable value	33
-----------------	----

unit:  $\mu\text{m}$

Remark: The values can be applied to 100 mm of the effective length of the track groove part at any position.

**Table 3 Allowable values of total radial runout of shaft with grooved raceway axial line**

Overall length of shaft with grooved raceway mm		Size				
		6	8	10	13	16, 20
Over	Incl.					
–	200	142	142	129	129	126
200	315	203	203	153	153	141
315	400	–	255	173	173	153
400	500	–	306	193	193	165
500	630	–	–	221	221	182
630	800	–	–	–	260	207
800	1 000	–	–	–	–	240

unit:  $\mu\text{m}$

Remark: These are values when an internal clearance is 0  $\mu\text{m}$ .

**Table 4 Measuring methods of accuracy**

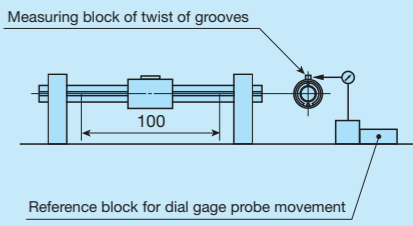
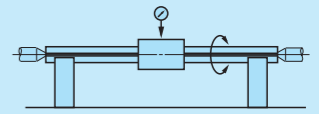
Item	Measuring method	Illustration of measuring method
Twist of grooves with respect to effective length of track groove (See Table 2)	While supporting the shaft with grooved raceway, apply a unidirectional torsion moment load to the external cylinder, place the dial gage probe vertically to the shaft with grooved raceway on the side face of the measuring block of twist of grooves attached on the external cylinder, and measure the deflection when the external cylinder and the dial gage probe are moved 100 mm in the axial direction at any position on the effective length of track groove of the shaft with grooved raceway. However, the dial gage probe should be applied as near as possible to the outer peripheral face of the external cylinder.	
Total radial runout of axial line of shaft with grooved raceway (See Table 3)	While supporting the shaft with grooved raceway at its supporting parts or at both centers, place a dial gage probe on the outer peripheral face of the external cylinder, and measure the deflection from one rotation of the shaft with grooved raceway at several positions in the axial direction to obtain the maximum value.	

# Internal Clearance

The internal clearance of LMG series is approximately 10  $\mu\text{m}$ .

## Load Direction and Load Rating

The LMG series must be used with its load rating corrected in accordance to the load direction. The basic dynamic load rating and basic static load rating shown in the dimension table should be corrected to values in Table 4.

Table 4 Load ratings corrected for load direction

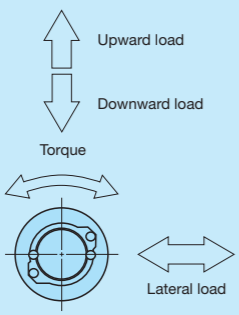

Size	Basic dynamic load rating			Basic static load rating		
	Load direction			Load direction		
	Downward	Upward	Lateral	Downward	Upward	Lateral
6~20	C	C	1.43C	$C_0$	$C_0$	$1.73C_0$

## Identification number and quantity for ordering

To order an assembled set of LMG series, please specify the number of sets based on the number of shafts with grooved raceway. For external cylinders or single shafts with grooved raceway, please specify the number of units.

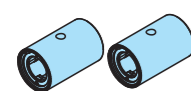
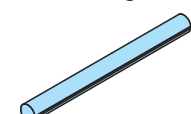
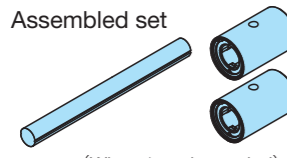
 (When 2 pieces are needed)	Example of identification number indication <b>LMG 10 C1 /U</b> Only C1 can be specified.	Order quantity <b>2 pieces</b>
 (When 1 unit is needed)	Example of identification number indication <b>LMG T 10 R300</b>	Order quantity <b>1 unit</b>
 (When 1 set is needed)	Example of identification number indication <b>LMG T 10 C2 R300 /U</b>	Order quantity <b>1 set</b>

## Moment of Inertia of Sectional Area and Section Coefficient of Shaft with Grooved Raceway

Table 5 Moment of inertia of sectional area and section coefficient of shaft with grooved raceway

Size	Moment of inertia of sectional area mm <sup>4</sup>		Section coefficient mm <sup>3</sup>	
	Solid shaft	Hollow shaft	Solid shaft	Hollow shaft
6	60	59	20	20
8	190	190	49	48
10	470	460	95	93
13	1 360	1 300	210	200
16	3 130	2 930	390	360
20	7 720	7 230	770	720

## Lubrication

Grease is not pre-packed in the LMG series, so please perform adequate lubrication as needed. Both oil lubrication and grease lubrication are available in the LMG series. For grease lubrication, use of high-quality lithium-soap base grease is recommended.

## Dust Protection

No dust protection seal is provided for LMG series. For applications in other than clean environment, cover the entire unit with a protective case, etc. to prevent harmful foreign substances such as dust and particles from outside from entering. The special specification with end seals (supplemental code / U) has a dust protection effect. However, if large amount of contaminant or dust are floating, or if large particles of foreign substances such as chips or sand may adhere to the shaft with grooved raceway, it is recommended to attach a protective cover to the linear motion mechanism.

## Precaution for Use

### 1 Fitting of external cylinder

Generally, clearance fit (H7) is recommended for fitting between the external cylinder and the housing bore. The transition fit (J7) may be applied for special use.

### 2 Typical mounting structure

Mounting examples of the external cylinder are shown in Fig. 1. The fixing thread depth of mounting screws for the external cylinder must not exceed the maximum fixing thread depth indicated in the dimension table. Since the screw hole for the external cylinder is penetrated, the shaft with grooved raceway will be pushed by the screw if the fixing thread depth is too deep, and the running accuracy and life will be adversely affected.

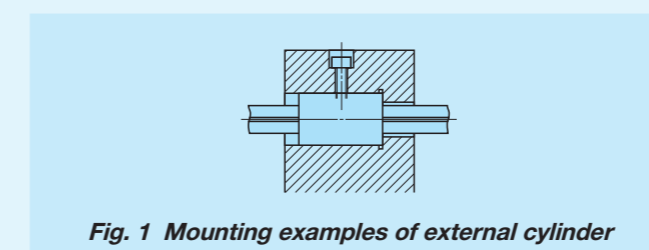

Fig. 1 Mounting examples of external cylinder

### 3 Operating temperature

The maximum operating temperature is 120°C and temperature up to 100°C is allowed for continuous operation. When the temperature exceeds 100°C, contact IKO.

### 4 Mounting of external cylinder

When press-fitting the external cylinder to the housing, assemble them correctly by using a press and a suitable jig fixture. (See Fig. 2.)

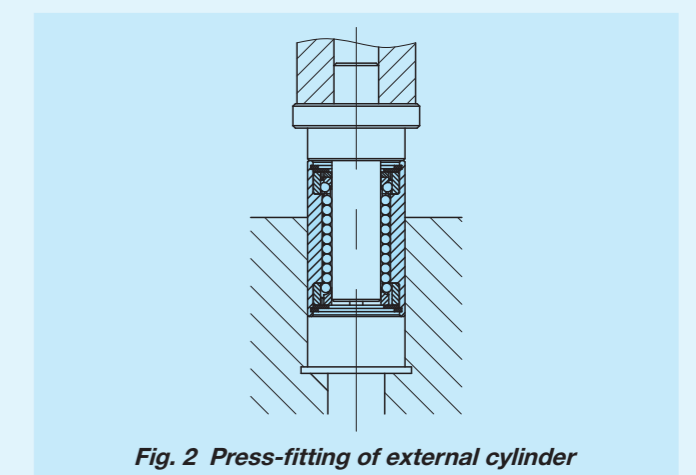

Fig. 2 Press-fitting of external cylinder

### 5 Multiple external cylinders used in close proximity

When using multiple external cylinders in close distance to the same housing, it is recommended to ensure that the distance between the external cylinders is three times as long as the length of the external cylinder. When using multiple external cylinders in closer distance, contact IKO.

### 6 Loaded condition with rotating torque

Use IKO Linear Ball Spline G under loaded conditions with a rotating torque bi-directionally or repeatedly.

Shape	LMG					
Size	6	8	10	13	16	20

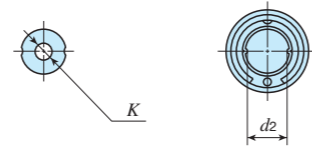

Hollow shaft dimension for LMGT

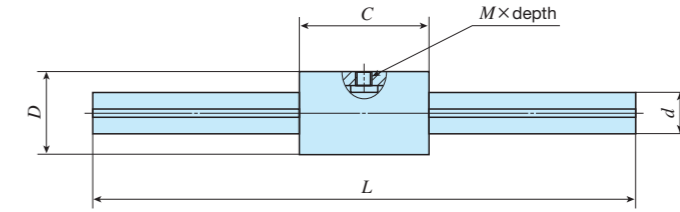

Identification number	Interchangeable	Mass (Ref.) g		Nominal dimensions and tolerances mm										Basic dynamic load rating C N	Basic static load rating C <sub>0</sub> N	Dynamic <sup>(5)</sup> torque rating T N · m	Static <sup>(5)</sup> torque rating T <sub>0</sub> N · m	
		External cylinder	Shaft with grooved raceway <sup>(1)</sup>	D	Dim. D tolerance	C	Dim. C tolerance	M × depth <sup>(2)</sup>	d	Dim. d tolerance	d <sub>2</sub> <sup>(3)</sup>	K	L <sup>(4)</sup>					Maximum length
LMG 6	○	9.4	22.0	12	0 -0.011	19	0 -0.200	M2.5 × 1.9 (2.5)	6	0 -0.012	5.2	-	150 200	300	587	641	2.1	2.2
LMGT 6	○		19.5															
LMG 8	○	15.7	39.3	15	0 -0.011	24	0 -0.200	M3 × 2.4 (3)	8	0 -0.015	7	-	150 200 250	500	769	962	3.5	4.3
LMGT 8	○		33.7											400				
LMG 10	○	31.5	61.2	19	0 -0.013	29	0 -0.200	M3 × 3.1 (4)	10	0 -0.015	8.9	-	200 300	600	1 410	1 710	8.0	9.7
LMGT 10	○		51.4															
LMG 13	○	45.4	104	23	0 -0.013	32	0 -0.200	M3 × 3.4 (4.5)	13	0 -0.018	11.9	-	200 300 400	800	1 880	2 150	13.7	15.7
LMGT 13	○		81.4															
LMG 16	○	78.2	157	28	0 -0.013	37	0 -0.200	M4 × 4.1 (5.5)	16	0 -0.018	14	-	200 300 400	1 000	2 590	2 930	23.1	26.1
LMGT 16	○		118															
LMG 20	○	110	246	32	0 -0.016	42	0 -0.200	M4 × 4.1 (5.5)	20	0 -0.021	17.5	-	300 400 500 600	1 000	3 010	3 660	32.8	39.9
LMGT 20	○		185															

- Notes (1) The mass of the shaft with grooved raceway is the value per 100 mm of the track groove part.  
 (2) The values in ( ) are the maximum fixing thread depth.  
 (3) d<sub>2</sub> represents the maximum diameter for end machining. (Perform annealing if end machining will be performed.)  
 (4) Represents standard length. We can produce other than the standard length, please specify the length of the shaft with grooved raceway by indicating the length in mm with the identification number.  
 (5) Applicable under loaded conditions with an unidirectional torque at all times.  
 Use IKO Linear Ball Spline G under loaded conditions with a rotating torque bi-directionally or repeatedly.
- Remark: Linear Bushing G are all interchangeable specification.

LMG · LM · LMS

# Linear Bushing

# LM



## Points

### ● Simple replacement for rolling guide

Since the structure adopts the raceway to be run along the shaft, the rolling guide of conventional bushing type can be easily modified to rolling guide without major design changes.

### ● Wide range of variations for your needs

For each dimensional series, standard, adjustable clearance, and open types are available with and without seals. You can select an optimal Linear Bushing for the specifications of your machine and device.

### ● Stainless steel superior in corrosion resistance are listed on lineup.

Products made of stainless steel are highly resistant to corrosion, so that they are suitable for applications where rust prevention oil is not preferred, such as in a cleanroom environment.

## Identification Number and Specification

### Example of an identification number

The specification of LM series is indicated by the identification number. Indicate the identification number, consisting of a model code, dimensions, a material code, a part code, a shape code, and a classification symbol for each specification to apply.

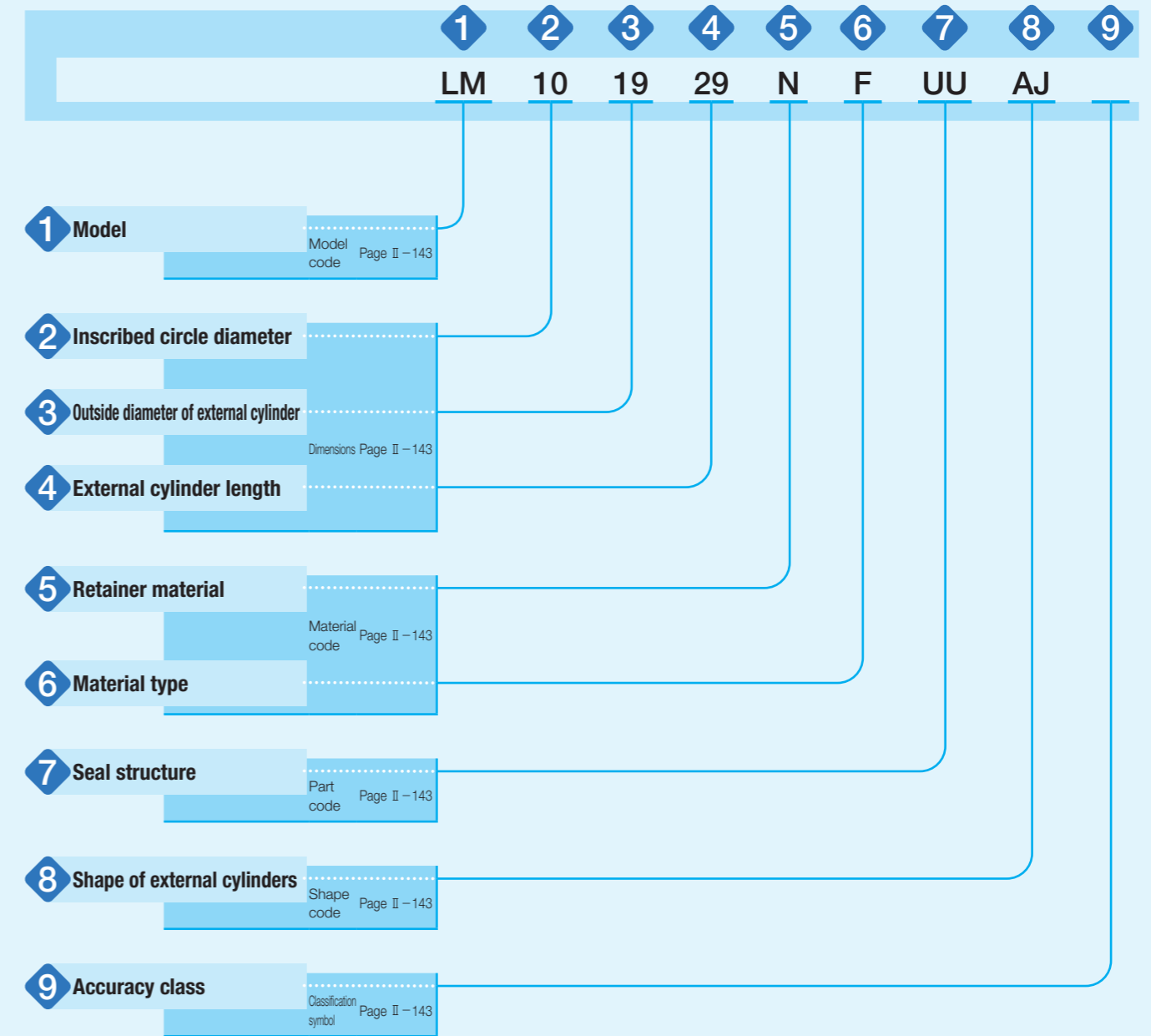



LMG · LM · LMS

<b>1 Model</b>	Linear Bushing (LM Series)	Metric series : LM : LME (European specification <sup>(1)</sup> ) Inch series : LMB	
	For applicable models and sizes, see Table 1.		
<b>2 Inscribed circle diameter</b>		For the metric series, indicate the inscribed circle diameter in mm. For the inch series, indicate the inscribed circle diameter in the unit of 1/16 inch.	
<b>3 Outside diameter of external cylinder</b>		For the metric series, indicate the outside diameter of external cylinder in mm. For the inch series, indicate the outside diameter of external cylinder in the unit of 1/16 inch.	
<b>4 External cylinder length</b>		For the metric series, indicate the length of the external cylinder in mm. For the inch series, indicate the length of external cylinder in the unit of 1/16 inch.	
<b>5 Retainer material</b>	High carbon steel made : No symbol Synthetic resin made : N	Specify the retainer material. For applicable models and sizes, see the "Identification number" column in the dimension table on pages II-147 to II-168.	
<b>6 Material type</b>	High carbon steel made : No symbol Stainless steel made : F <sup>(2)</sup>	Specify the component part material. For applicable models and sizes, see the "Identification number" column in the dimension table on pages II-147 to II-168.	
<b>7 Seal structure</b>	Without seal : No symbol With one end seal : U With two end seals : UU	The models with one end seal and two end seals incorporate seals with superior dust protection performance for preventing intrusion of foreign substances. For the inch series, only the type without seal (no symbol) can be specified. The maximum allowable temperature for seals is 120°C.	
<b>8 Shape of external cylinders</b>	Standard type : No symbol Adjustable clearance type : AJ Open type : OP	For applicable models and sizes, see Table 1.	
<b>9 Accuracy class</b>	High : No symbol Precision : P	High class (no symbol) and precision class (P) are available for the accuracy class of LM and LMB standard type series. For the adjustable clearance type and the open type, only high class (no symbol) is available, and the accuracy values are applicable only before cutting the external cylinders. For details of accuracy, see the dimension table on pages II-147 to II-168.	

Note <sup>(1)</sup> It is specification with the dimensions and tolerances generally used in Europe.  
<sup>(2)</sup> The cage will be always stainless steel even when high carbon steel (no symbol) is specified.

Table 1 Models and sizes of LM series

External cylinder shape	Dimensional series	Material type	Seal structure	Model	Size (Shaft diameter)	
Standard type 	Metric series	High carbon steel made	Without seal	LM LME	6 ~150 mm 5 ~ 80 mm	
			With one end seal	LM ... U LME ... U	6 ~150 mm 5 ~ 80 mm	
			With two end seals	LM ... UU LME ... UU	6 ~150 mm 5 ~ 80 mm	
		Stainless steel made	Without seal	LM ... F LME ... F	6 ~ 60 mm 5 ~ 60 mm	
			With one end seal	LM ... F U LME ... F U	6 ~ 60 mm 5 ~ 60 mm	
			With two end seals	LM ... F UU LME ... F UU	6 ~ 60 mm 5 ~ 60 mm	
	Inch series	High carbon steel made	Without seal	LMB	6.350~101.6 mm (1/4~ 4in)	
	Adjustable clearance type 	Metric series	High carbon steel made	Without seal	LM ... AJ LME ... AJ	6 ~150 mm 5 ~ 80 mm
				With one end seal	LM ... U AJ LME ... U AJ	6 ~150 mm 5 ~ 80 mm
With two end seals				LM ... UU AJ LME ... UU AJ	6 ~150 mm 5 ~ 80 mm	
Stainless steel made			Without seal	LM ... F AJ LME ... F AJ	6 ~ 60 mm 5 ~ 60 mm	
			With one end seal	LM ... F U AJ LME ... F U AJ	6 ~ 60 mm 5 ~ 60 mm	
			With two end seals	LM ... F UU AJ LME ... F UU AJ	6 ~ 60 mm 5 ~ 60 mm	
Inch series		High carbon steel made	Without seal	LMB ... AJ	6.350~101.6 mm (1/4~ 4in)	
Open type 		Metric series	High carbon steel made	Without seal	LM ... OP LME ... OP	10 ~150 mm 12 ~ 80 mm
				With one end seal	LM ... U OP LME ... U OP	10 ~150 mm 12 ~ 80 mm
	With two end seals			LM ... UU OP LME ... UU OP	10 ~150 mm 12 ~ 80 mm	
	Stainless steel made		Without seal	LM ... F OP LME ... F OP	10 ~ 60 mm 12 ~ 60 mm	
			With one end seal	LM ... F U OP LME ... F U OP	10 ~ 60 mm 12 ~ 60 mm	
			With two end seals	LM ... F UU OP LME ... F UU OP	10 ~ 60 mm 12 ~ 60 mm	
	Inch series	High carbon steel made	Without seal	LMB ... OP	12.700~101.6 mm (1/2~ 4in)	

Standard type : Product with high accuracy used generally over a wide range

Adjustable clearance type : This type has a cut-away slit in an axial direction of external cylinder, which is capable of clearance adjustment. If installed in a housing whose inscribed circle diameter is adjustable, it enables radial clearance to be freely adjusted without optional fitting and also enables preloading to operate.

Open type : This type is in sectoral form with the external cylinder cut away in slit by one-row raceway or two-row raceways of ball in an axial direction. In order to avoid the occurrence of long shaft deflection, it is possible to accordingly add the shaft support block tailored to (E) dimension of the sectoral form shown in the dimension table, in a midway point. And, it is also capable of clearance adjustment.

## Relationship between Load Rating and Ball Raceway

The load rating of LM series varies according to the loading direction and position of ball raceway. The dimension table describes two types of values shown in Fig. 1.1 and Fig. 1.2 according to the loading direction and position of ball raceway.

Fig. 1.1 shows the case where the loading direction and ball raceway position coincides with each other, representing the loading direction A in the dimension table. Generally, this is applied when the ball raceway position cannot be specified to indeterminate direction load or loading direction.

Fig. 1.2 shows the case where the loading direction is positioned between ball raceways, representing the loading direction B in the dimension table. Generally, this can be subjected to load bigger than loading direction A.

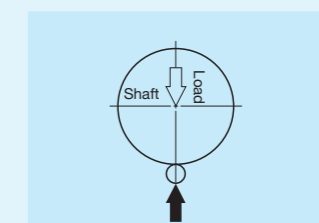

Fig. 1.1 Loading direction A

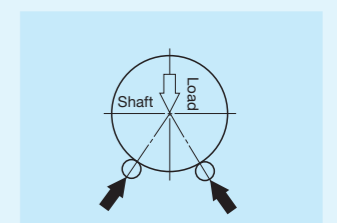

Fig. 1.2 Loading direction B

1N=0.102kgf=0.2248lbs.  
1mm=0.03937inch

# Lubrication

Grease is not pre-packed in the LM series, so please perform adequate lubrication as needed. Both of oil lubrication and grease lubrication are available in the LM series. For grease lubrication, use of high-quality lithium-soap base grease is recommended.

# Precaution for Use

## ①Fitting

For fitting with a housing hole, clearance fit is usually used but transition fit can also be used for special usage. For adjustable clearance type and open type, the shaft diameter shall be set as much as possible to less than the lower limit of the allowance of the inscribed circle diameter, and while the dimension of a housing hole shall be set to more than the upper limit of the allowance of the outside diameter of the external cylinder.

Table 2 Recommended fit

Models and accuracy class	Tolerance class				
	Shaft		Housing hole		
	Ordinary clearance	Interference fit	Clearance fit	Transition fit	
LM, LMB	High	f6, g6	h6	H7	J7
	Precision	f5, g5	h5	H6	J6
LME	—	h6	j6	H7	J7

## ②Clearance

For adjustable clearance type and open type, clearance adjustment can be easily performed if the unit is mounted into a housing with the bore diameter dimension adjustable. However, if a large preload is produced due to the clearance adjustment, the deformation at the contact portion of the external cylinder and ball may become large, thereby deteriorating the life. Therefore, it is recommended to finish the shaft dimension within the allowance of the recommended fitting and set the clearance at zero or under a slightly-preloaded condition. Although the clearance adjustment is performed while measuring the clearance with a dial gauge after fitting in a shaft, a method is generally taken to rotate the shaft under unloaded condition during clearance adjustment and stop the adjustment at the timing when detecting a slight resistance. At this time, the Linear Bushing clearance is at zero or under a slight preload condition. Meanwhile, the clearance adjustment for open type with three-row ball raceways cannot be performed.

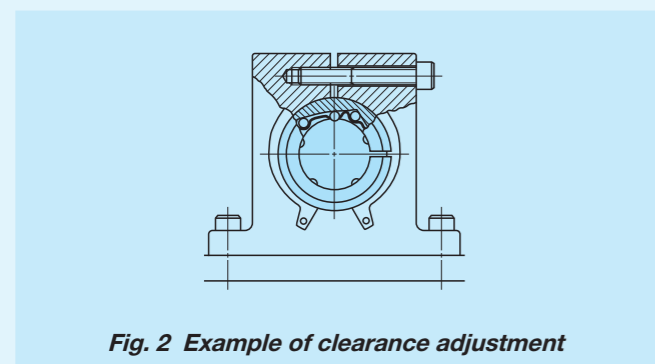

Fig. 2 Example of clearance adjustment

## ③Raceway

Since LM series operates with a shaft as a raceway surface, the shaft should be heat-treated and ground. Recommended values for surface hardness and roughness of the shaft are shown in Table 3 and the recommended value for the minimum effective hardening depth is shown in Table 4.

Table 3 Surface hardness and roughness of shaft

Item	Recommended value	Remark
Surface hardness	58~64HRC	When the surface hardness is low, multiply the load rating by hardness factor (1).
Surface roughness	0.2 μmRa or lower (0.8 μmRy or lower)	Where accuracy standard is low, around 0.8 μmRa (3.2 μmRy) is also allowed.

Note (1) For hardness factor, refer to Fig. 3 in page III-5.

Table 4 Minimum effective hardening depth of shaft unit: mm

Shaft diameter		Recommended value for minimum effective hardening depth
Over	Incl.	
—	28	0.8
28	50	1.0
50	100	1.5
100	150	2.0

## ④When accompanied by rotational motion

LM series units support only linear motion but do not support rotational motion. When performing rotational motion and linear motion of short stroke length, IKO Stroke Rotary Bushing is recommended to be used. And, for the usage requiring rotational motion and linear motion of long stroke length, it is recommended to use in combination with IKO needle bearing as shown in Fig. 3.

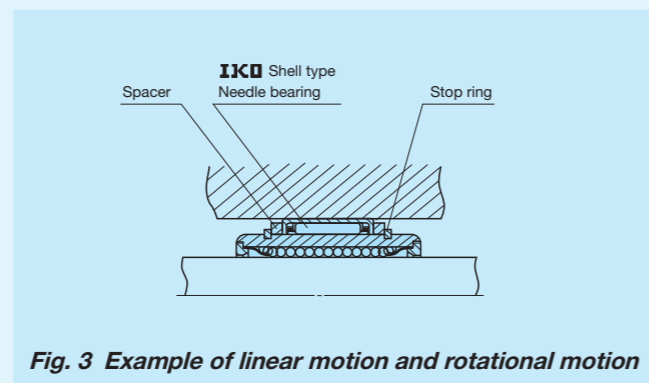

Fig. 3 Example of linear motion and rotational motion

## ⑤Precaution for use of open type with three-row linear bushing

The open type with three-row Linear Bushing of balls may only be used with load direction indicated in Fig. 4.1. In addition, if two of them are used in parallel, mount them as indicated in 4.2, taking into account the load distribution to rolling elements. And, note that the clearance adjustment cannot be performed.

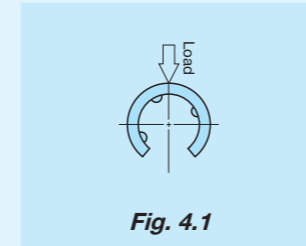

Fig. 4.1

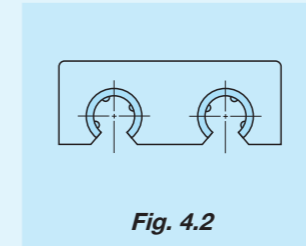

Fig. 4.2

## ⑥Operating temperature

If the retainer is made of carbon steel, it can withstand higher temperature. However, if you use it in an environment exceeding 100°C, please contact IKO. The maximum operating temperature of synthetic resin made products is 100°C and temperature up to 80°C is allowed for continuous operation.

## ⑦Mounting

When pressing an external cylinder into the housing hole, do it softly while applying a jig to the sides of the external cylinder not to hit the end plate (see Fig. 5). After pressing-in, use a stop ring or stopper plate to fix it in an axial direction. When inserting shaft after mounting the external cylinder, be careful not to shock the ball or retainer. In addition, when two shafts are used, mount one accurately and then the other by referring to the first one so as to ensure parallelism with it. Typical mounting example is shown in Fig. 6.

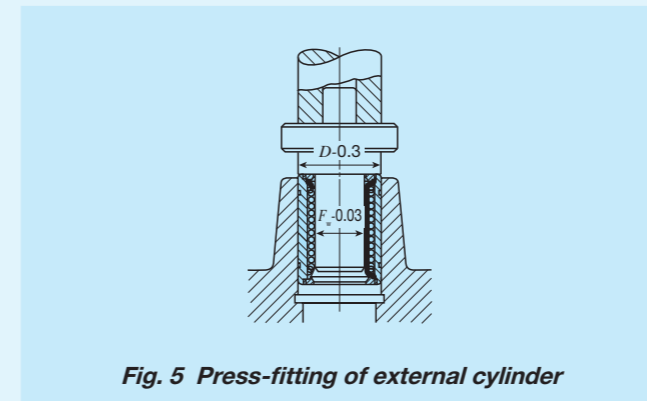

Fig. 5 Press-fitting of external cylinder

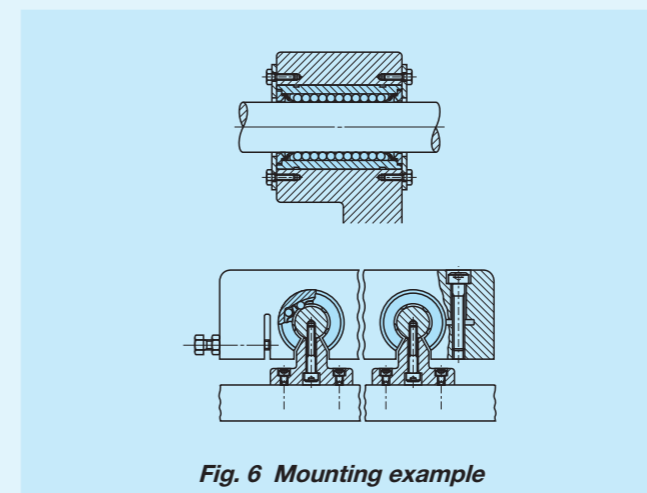

Fig. 6 Mounting example

# Related Products

## Slide shaft

To make full use of performance of the LM series, we also offer shaft with high accuracy for Linear Bushing grounded after heat treatment. If you are interested, contact IKO. Conventional ordinary type shafts are also available.

## Felt seals for Linear Bushing

Though the type with seal is standardized for the LM series, the type without seal and felt seals may be used together when emphasis is put on rolling friction resistance. Dimensions for felt seals are shown in Table 5.

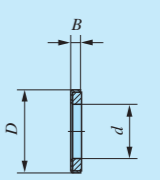

Table 5 Dimensions of felt seals for Linear Bushing



Identification number	unit: mm		
	d	D	B
FLM 6	6	12	2
FLM 8	8	15	2
FLM 10	10	19	3
FLM 13	13	23	3
FLM 16	16	28	4
FLM 20	20	32	4
FLM 25	25	40	5
FLM 30	30	45	5
FLM 35	35	52	5
FLM 40	40	60	5
FLM 50	50	80	10
FLM 60	60	90	10
FLM 80	80	120	10
FLM 100	100	150	10

Remark: For adjustable clearance type, open type and inch series felt seals, contact IKO.



	Standard type					Adjustable clearance type					Open type							
Shape	LM LM...N					LM...AJ LM...N AJ					LM...OP LM...N OP							
																		
Shaft diameter	6	8	10	12	13	16	6	8	10	12	13	16	—	—	10	12	13	16
	20	25	30	35	40	50	20	25	30	35	40	50	20	25	30	35	40	50
	60	80	100	120	150	60	80	100	120	150	60	80	100	120	150			

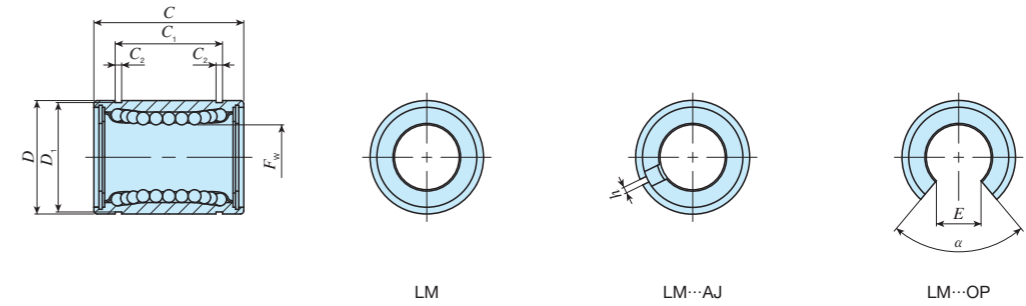



Shaft diameter mm	Identification number										Nominal dimensions and tolerances mm										Eccentricity		Basic dynamic load rating		Basic static load rating						
	Standard type		Ball raceway	Mass (Ref.) g	Adjustable clearance type		Ball raceway	Mass (Ref.) g	Open type		Ball raceway	Mass (Ref.) g	$F_w$	Dim. $F_w$ tolerance $\mu\text{m}$		$D$	Dim. $D$ tolerance $\mu\text{m}$	$C$	Dim. $C$ tolerance $\mu\text{m}$	$C_1$ (1)	Dim. $C_1$ tolerance $\mu\text{m}$	$C_2$	$D_1$	$h$	$E$	$\alpha$ Degree	Maximum $\mu\text{m}$ P H	Load rating $C$		Load rating $C_0$	
	P	H			Load direction A N	Load direction B N			Load direction A N	Load direction B N																					
6	LM 61219	4	8	—	—	—	—	—	—	—	—	6			12		19		13.5		1.1	11.5	—	—			80.7	92.7	167	237	
	LM 61219 N	4	7.6	LM 61219 N AJ*	4	7.5	—	—	—	—	—	8			15	0	17		11.5		1.1	14.3	—	—			87.4	100	160	226	
8	LM 81517	4	13	—	—	—	—	—	—	—	—	8			15	-11	24		17.5		1.1	14.3	—	—			121	139	255	361	
	LM 81524	4	18	—	—	—	—	—	—	—	—	8			15		24		17.5		1.1	14.3	—	—			121	139	255	361	
10	LM 101929	4	30	—	—	—	—	—	—	—	—	10	0	0	19		29		22		1.3	18	—	—			179	206	354	501	
	LM 101929 N	4	27.5	LM 101929 N AJ*	4	26.5	LM 101929 N OP*	3	18	—	—	10	-6	-9	19		29		22		1.3	18	1	6.8	80	8	12	179	206	354	501
12	LM 122130	4	29	LM 122130 AJ*	4	28	LM 122130 OP*	3	19	—	—	12			21	0	30	-200	23	-200	1.3	20	1.5	8	80			259	298	503	711
	LM 122130 N	4	31.5	LM 122130 N AJ*	4	30.5	LM 122130 N OP*	3	22	—	—	12			21	0	30	-200	23	-200	1.3	20	1.5	8	80			259	298	503	711
13	LM 132332	4	43	LM 132332 AJ*	4	42	LM 132332 OP*	3	31	—	—	13			23	-13	32		23		1.3	22	1.5	9	80			266	306	506	716
	LM 132332 N	4	42.5	LM 132332 N AJ*	4	41.5	LM 132332 N OP*	3	31	—	—	13			23	-13	32		23		1.3	22	1.5	9	80			266	306	506	716
16	LM 162837	4	70	LM 162837 AJ*	4	69.5	LM 162837 OP*	3	58	—	—	16			28		37		26.5		1.6	27	1.5	11	80			426	489	766	1 080
	LM 162837 N	4	69	LM 162837 N AJ*	4	68	LM 162837 N OP*	3	52	—	—	16			28		37		26.5		1.6	27	1.5	11	80			426	489	766	1 080
20	LM 203242	5	92	LM 203242 AJ*	5	91	LM 203242 OP*	4	79	—	—	20			32		42		30.5		1.6	30.5	1.5	11	60			562	668	1 010	1 470
	LM 203242 N	5	87	LM 203242 N AJ*	5	85	LM 203242 N OP*	4	69	—	—	20			32		42		30.5		1.6	30.5	1.5	11	60			562	668	1 010	1 470
25	LM 254059	6	226	LM 254059 AJ*	6	222	LM 254059 OP*	5	203	—	—	25	0	0	40	0	59		41		1.85	38	2	12	50	10	15	920	974	1 780	2 280
	LM 254059 N	6	220	LM 254059 N AJ*	6	216	LM 254059 N OP*	5	188	—	—	25	-7	-10	40	-16	59		41		1.85	38	2	12	50	10	15	920	974	1 780	2 280
30	LM 304564	6	253	LM 304564 AJ*	6	250	LM 304564 OP*	5	228	—	—	30			45		64		44.5		1.85	43	2.5	15	50			1 460	1 540	2 780	3 560
	LM 304564 N	6	250	LM 304564 N AJ*	6	245	LM 304564 N OP*	5	210	—	—	30			45		64		44.5		1.85	43	2.5	15	50			1 460	1 540	2 780	3 560
35	LM 355270	6	388	LM 355270 AJ*	6	380	LM 355270 OP*	5	355	—	—	35			52		70	0	49.5	0	2.1	49	2.5	17	50			1 610	1 710	3 080	3 940
	LM 355270 N	6	380	LM 355270 N AJ*	6	375	LM 355270 N OP*	5	335	—	—	35			52		70	-300	49.5	-300	2.1	49	2.5	17	50			1 610	1 710	3 080	3 940
40	LM 406080	6	596	LM 406080 AJ*	6	585	LM 406080 OP*	5	546	—	—	40	0	0	60	0	80		60.5		2.1	57	3	20	50	12	20	2 030	2 150	3 620	4 640
	LM 406080 N	6	585	LM 406080 N AJ*	6	579	LM 406080 N OP*	5	500	—	—	40	-8	-12	60	-19	80		60.5		2.1	57	3	20	50	12	20	2 030	2 150	3 620	4 640
50	LM 5080100	6	1 615	LM 5080100 AJ*	6	1 595	LM 5080100 OP*	5	1 420	—	—	50			80		100		74		2.6	76.5	3	25	50			3 940	4 180	7 130	9 120
	LM 5080100 N	6	1 580	LM 5080100 N AJ*	6	1 560	LM 5080100 N OP*	5	1 340	—	—	50			80		100		74		2.6	76.5	3	25	50			3 940	4 180	7 130	9 120

Note (1) The width of hub for fixing with circlip should be the value obtained by subtracting a circlip width value times two from the  $C_1$  dimension.

- Remarks 1. "P" and "H" in Dim.  $F_w$  tolerance and Eccentricity represent precision and high, respectively.  
 2. Standard type and adjustable clearance type end plates are fixed with stop ring for holes.  
 3. The identification numbers with \* are our semi-standard items.

# IKO Linear Bushing

	Standard type						Adjustable clearance type						Open type					
Shape	LM LM...N						LM... AJ LM...N AJ						LM... OP LM...N OP					
																		
Shaft diameter	6	8	10	12	13	16	6	8	10	12	13	16	—	—	10	12	13	16
	20	25	30	35	40	50	20	25	30	35	40	50	20	25	30	35	40	50
	60	80	100	120	150	60	80	100	120	150	60	80	100	120	150			

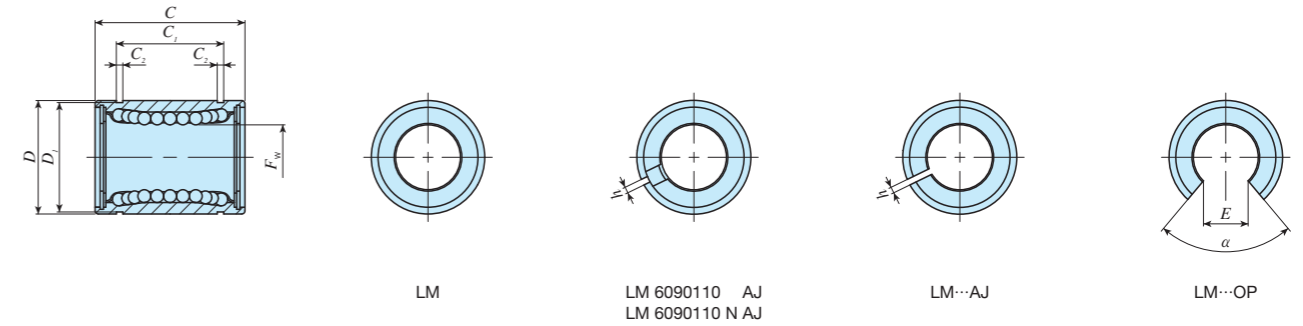



Shaft diameter mm	Identification number										Nominal dimensions and tolerances mm												Eccentricity		Basic dynamic load rating		Basic static load rating						
	Standard type		Ball raceway	Mass (Ref.) g	Adjustable clearance type		Ball raceway	Mass (Ref.) g	Open type		Ball raceway	Mass (Ref.) g	$F_w$	Dim. $F_w$ tolerance $\mu\text{m}$		$D$	Dim. $D$ tolerance $\mu\text{m}$	$C$	Dim. $C$ tolerance $\mu\text{m}$	$C_1^{(1)}$	Dim. $C_1$ tolerance $\mu\text{m}$	$C_2$	$D_1$	$h$	$E$	$\alpha$ Degree	Maximum $\mu\text{m}$	P	H	$C$		$C_0$	
	P	H			P	H			P	H				Load direction A N	Load direction B N															Load direction A N	Load direction B N		
60	LM 6090110	6	1 817	LM 6090110 AJ*	6	1 788	LM 6090110 OP*	5	1 650	60	0	0	90	0	110	0	85	0	3.15	86.5	3	30	50	17	25	4 760	5 040	8 150	10 400				
	LM 6090110 N	6	1 787	LM 6090110 N AJ*	6	1 757	LM 6090110 N OP*	5	1 610	60	-9	-15	120	-22	140	-300	105.5	-300	4.15	116	3	40	50	17	25	8 710	9 220	14 500	18 500				
80	LM 80120140*	6	4 520	LM 80120140 AJ*	6	4 400	LM 80120140 OP*	5	3 750	80	0	0	150	0	175	0	125.5	0	4.15	145	3	50	50	20	30	14 500	15 300	22 800	29 200				
100	LM 100150175*	6	8 600	LM 100150175 AJ*	6	8 540	LM 100150175 OP*	5	7 200	100	0	0	150	0	175	0	125.5	0	4.15	145	3	50	50	20	30	14 500	15 300	22 800	29 200				
120	LM 120180200*	8	15 000	LM 120180200 AJ*	8	14 900	LM 120180200 OP*	6	11 600	120	-10	-20	180	-25	200	-400	158.6	-400	4.15	175	3	85	80	20	30	25 800	25 500	44 300	49 400				
150	LM 150210240*	8	20 250	LM 150210240 AJ*	8	20 150	LM 150210240 OP*	6	15 700	150	0	0	210	0	240	-400	170.6	-400	5.15	204	3	105	80	25	40	35 600	35 100	61 200	68 200				

Note (1) The width of hub for fixing with circlip should be the value obtained by subtracting a circlip width value times two from the  $C_1$  dimension.

- Remarks 1. "P" and "H" in Dim.  $F_w$  tolerance and Eccentricity represent precision and high, respectively.  
 2. Standard type and adjustable clearance type (shaft diameter 60 mm) end plates are fixed with stop ring for holes.  
 3. The identification numbers with \* are our semi-standard items.

LMG • LM • LMS

# IKO Linear Bushing With Seal

	Standard type					Adjustable clearance type					Open type							
Shape	LM... UU LM...N UU					LM... UU AJ LM...N UU AJ					LM... UU OP LM...N UU OP							
																		
Shaft diameter	6	8	10	12	13	16	6	8	10	12	13	16	—	—	10	12	13	16
	20	25	30	35	40	50	20	25	30	35	40	50	20	25	30	35	40	50
	60	80	100	120	150	60	80	100	120	150	60	80	100	120	150			

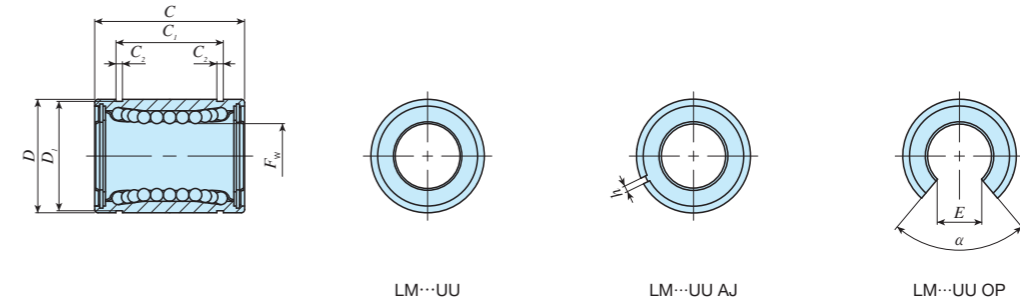



Shaft diameter mm	Identification number										Nominal dimensions and tolerances mm														Eccentricity		Basic dynamic load rating		Basic static load rating				
	Standard type		Ball raceway	Mass (Ref.) g	Adjustable clearance type		Ball raceway	Mass (Ref.) g	Open type		Ball raceway	Mass (Ref.) g	F <sub>w</sub>	Dim. F <sub>w</sub> tolerance μm		D	Dim. D tolerance μm	C	Dim. C tolerance μm	C <sub>1</sub> (1)	Dim. C <sub>1</sub> tolerance μm	C <sub>2</sub>	D <sub>1</sub>	h	E	α	Maximum μm	P	H	Load direction A N	Load direction B N	Load direction A N	Load direction B N
6	LM 61219 UU	4	8	—	—	—	—	—	—	—	—	6			12		19		13.5		1.1	11.5	—	—	—				80.7	92.7	167	237	
	LM 61219 N UU	4	7.6	LM 61219 N UU AJ*	4	7.5	—	—	—	—	—	8			15	0 -11	17		11.5		1.1	14.3	—	—	—				87.4	100	160	226	
8	LM 81517 UU	4	13	—	—	—	—	—	—	—	—	8			15		24		17.5		1.1	14.3	—	—	—				121	139	255	361	
	LM 81524 UU	4	18	—	—	—	—	—	—	—	—	8			15		24		17.5		1.1	14.3	—	—	—				121	139	255	361	
10	LM 101929 UU	4	30	—	—	—	—	—	—	—	—	10	0 -6	0 -9	19		29		22		1.3	18	—	—	—	8	12		179	206	354	501	
	LM 101929 N UU	4	27.5	LM 101929 N UU AJ*	4	26.5	LM 101929 N UU OP*	3	18	—	—	12			21	0	30	-200	23	-200	1.3	20	1.5	8	80			259	298	503	711		
12	LM 122130 UU	4	29	LM 122130 UU AJ*	4	28	LM 122130 UU OP*	3	19	—	—	12			21	0	30	-200	23	-200	1.3	20	1.5	8	80			259	298	503	711		
	LM 122130 N UU	4	31.5	LM 122130 N UU AJ*	4	30.5	LM 122130 N UU OP*	3	22	—	—	13			23	-13	32		23		1.3	22	1.5	9	80			266	306	506	716		
13	LM 132332 UU	4	43	LM 132332 UU AJ*	4	42	LM 132332 UU OP*	3	31	—	—	13			23		32		23		1.3	22	1.5	9	80			266	306	506	716		
	LM 132332 N UU	4	42.5	LM 132332 N UU AJ*	4	41.5	LM 132332 N UU OP*	3	31	—	—	16			28		37		26.5		1.6	27	1.5	11	80			426	489	766	1 080		
16	LM 162837 UU	4	70	LM 162837 UU AJ*	4	69.5	LM 162837 UU OP*	3	58	—	—	16			28		37		26.5		1.6	27	1.5	11	80			426	489	766	1 080		
	LM 162837 N UU	4	69	LM 162837 N UU AJ*	4	68	LM 162837 N UU OP*	3	52	—	—	20			32		42		30.5		1.6	30.5	1.5	11	60			562	668	1 010	1 470		
20	LM 203242 UU	5	92	LM 203242 UU AJ*	5	91	LM 203242 UU OP*	4	79	—	—	20			32		42		30.5		1.6	30.5	1.5	11	60			562	668	1 010	1 470		
	LM 203242 N UU	5	87	LM 203242 N UU AJ*	5	85	LM 203242 N UU OP*	4	69	—	—	25	0 -7	0 -10	40	0 -16	59		41		1.85	38	2	12	50	10	15		920	974	1 780	2 280	
25	LM 254059 UU	6	226	LM 254059 UU AJ*	6	222	LM 254059 UU OP*	5	203	—	—	25	0 -7	0 -10	40	0 -16	59		41		1.85	38	2	12	50	10	15		920	974	1 780	2 280	
	LM 254059 N UU	6	220	LM 254059 N UU AJ*	6	216	LM 254059 N UU OP*	5	188	—	—	30			45		64		44.5		1.85	43	2.5	15	50			1 460	1 540	2 780	3 560		
30	LM 304564 UU	6	253	LM 304564 UU AJ*	6	250	LM 304564 UU OP*	5	228	—	—	30			45		64		44.5		1.85	43	2.5	15	50			1 460	1 540	2 780	3 560		
	LM 304564 N UU	6	250	LM 304564 N UU AJ*	6	245	LM 304564 N UU OP*	5	210	—	—	35			52		70	-300	49.5	-300	2.1	49	2.5	17	50			1 610	1 710	3 080	3 940		
35	LM 355270 UU	6	387	LM 355270 UU AJ*	6	380	LM 355270 UU OP*	5	355	—	—	35			52		70	-300	49.5	-300	2.1	49	2.5	17	50			1 610	1 710	3 080	3 940		
	LM 355270 N UU	6	380	LM 355270 N UU AJ*	6	375	LM 355270 N UU OP*	5	335	—	—	40	0 -8	0 -12	60	0 -19	80		60.5		2.1	57	3	20	50	12	20		2 030	2 150	3 620	4 640	
40	LM 406080 UU	6	596	LM 406080 UU AJ*	6	585	LM 406080 UU OP*	5	546	—	—	40	0 -8	0 -12	60	0 -19	80		60.5		2.1	57	3	20	50	12	20		2 030	2 150	3 620	4 640	
	LM 406080 N UU	6	585	LM 406080 N UU AJ*	6	579	LM 406080 N UU OP*	5	500	—	—	50			80		100		74		2.6	76.5	3	25	50			3 940	4 180	7 130	9 120		
50	LM 5080100 UU	6	1 615	LM 5080100 UU AJ*	6	1 595	LM 5080100 UU OP*	5	1 420	—	—	50			80		100		74		2.6	76.5	3	25	50			3 940	4 180	7 130	9 120		
	LM 5080100 N UU	6	1 580	LM 5080100 N UU AJ*	6	1 560	LM 5080100 N UU OP*	5	1 340	—	—																						

Note (1) The width of hub for fixing with circlip should be the value obtained by subtracting a circlip width value times two from the C<sub>1</sub> dimension.

- Remarks 1. "P" and "H" in Dim. F<sub>w</sub> tolerance and Eccentricity represent precision and high, respectively.  
 2. Standard type and adjustable clearance type end plates are fixed with stop ring for holes.  
 3. The identification numbers with \* are our semi-standard items.

LMG • LM • LMS

# IKO Linear Bushing With Seal

	Standard type						Adjustable clearance type						Open type						
Shape	LM... UU LM...N UU						LM... UU AJ LM...N UU AJ						LM... UU OP LM...N UU OP						
																			
Shaft diameter	6	8	10	12	13	16	6	8	10	12	13	16	—	—	10	12	13	16	
	20	25	30	35	40	50	20	25	30	35	40	50	20	25	30	35	40	50	
	60	80	100	120	150	60	80	100	120	150	60	80	100	120	150				

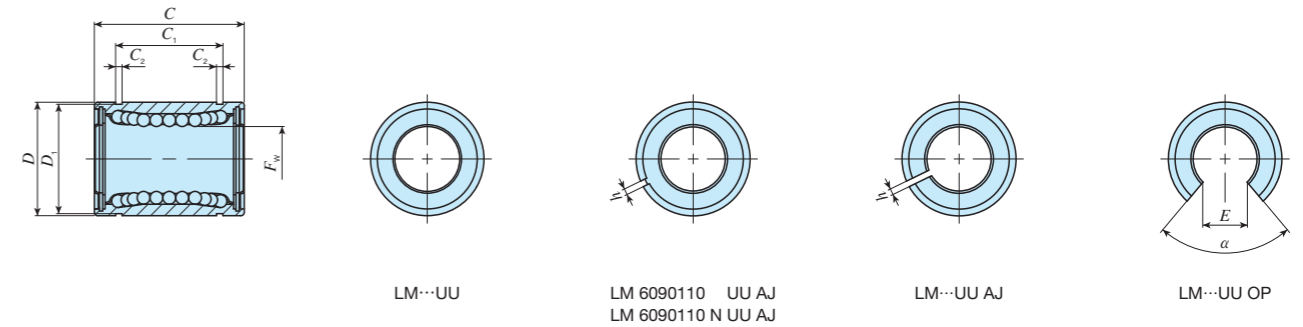



Shaft diameter mm	Identification number										Nominal dimensions and tolerances mm														Eccentricity		Basic dynamic load rating		Basic static load rating			
	Standard type		Ball raceway	Mass (Ref.)	Adjustable clearance type		Ball raceway	Mass (Ref.)	Open type		Ball raceway	Mass (Ref.)	$F_w$	Dim. $F_w$ tolerance $\mu\text{m}$		$D$	Dim. $D$ tolerance $\mu\text{m}$	$C$	Dim. $C$ tolerance $\mu\text{m}$	$C_1^{(1)}$	Dim. $C_1$ tolerance $\mu\text{m}$	$C_2$	$D_1$	$h$	$E$	$\alpha$	Maximum $\mu\text{m}$		Load direction A	Load direction B	Load direction A	Load direction B
	P	H	P	H	P	H	P	H	P	H	P	H		P	H												P	H				
60	LM 6090110 UU	6	1 817	LM 6090110 UU AJ*	6	1 788	LM 6090110 UU OP*	5	1 650			60	0	0	90	0	110	0	85	0	3.15	86.5	3	30	50	17	25	4 760	5 040	8 150	10 400	
	LM 6090110 N UU	6	1 787	LM 6090110 N UU AJ*	6	1 757	LM 6090110 N UU OP*	5	1 610			80	-9	-15	120	-22	140	-300	105.5	-300	4.15	116	3	40	50	20	30	8 710	9 220	14 500	18 500	
80	LM 80120140 UU*	6	4 400	LM 80120140 UU AJ*	6	4 360	LM 80120140 UU OP*	5	3 640			100	0	0	150	0	175	0	125.5	0	4.15	145	3	50	50	20	30	14 500	15 300	22 800	29 200	
120	LM 120180200 UU*	8	14 700	LM 120180200 UU AJ*	8	14 600	LM 120180200 UU OP*	6	11 400			120	-10	-20	180	-25	200	-400	158.6	-400	4.15	175	3	85	80	20	30	25 800	25 500	44 300	49 400	
150	LM 150210240 UU*	8	19 900	LM 150210240 UU AJ*	8	19 800	LM 150210240 UU OP*	6	15 400			150	0	0	210	0	240	0	170.6	0	5.15	204	3	105	80	25	40	35 600	35 100	61 200	68 200	

Note (1) The width of hub for fixing with circlip should be the value obtained by subtracting a circlip width value times two from the  $C_1$  dimension.

- Remarks 1. "P" and "H" in Dim.  $F_w$  tolerance and Eccentricity represent precision and high, respectively.  
 2. Standard type and adjustable clearance type (shaft diameter 60 mm) end plates are fixed with stop ring for holes.  
 3. The identification numbers with \* are our semi-standard items.

LMG • LM • LMS

	Standard type					Adjustable clearance type					Open type								
Shape	LME LME...N					LME... AJ LME...N AJ					LME... OP LME...N OP								
																			
Shaft diameter	5	8	12	16	20	25	5	8	12	16	20	25	—	—	12	16	20	25	
	30	40	50	60	80	30	40	50	60	80	30	40	50	60	80				

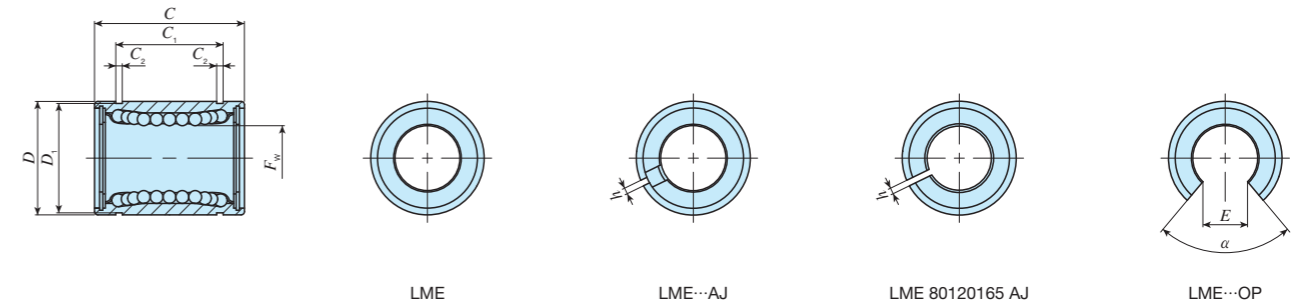



Shaft diameter mm	Identification number										Nominal dimensions and tolerances mm											Eccentricity Maximum μm	Basic dynamic load rating C		Basic static load rating C <sub>0</sub>					
	Standard type		Ball raceway	Mass (Ref.) g	Adjustable clearance type		Ball raceway	Mass (Ref.) g	Open type		Ball raceway	Mass (Ref.) g	F <sub>w</sub>	Dim. F <sub>w</sub> tolerance μm	D	Dim. D tolerance μm	C	Dim. C tolerance μm	C <sub>1</sub> ( <sup>1</sup> )	Dim. C <sub>1</sub> tolerance μm	C <sub>2</sub>		D <sub>1</sub>	h	E	α Degree	Load direction A N	Load direction B N	Load direction A N	Load direction B N
5	LME	51222 N*	4	11	LME	51222 N AJ*	4	9.5	—	—	—	5		12	0	22		14.5		1.1	11.5	1	—	—	12	90.8	104	219	310	
8	LME	81625 *	4	20	—	—	—	—	—	—	—	8	+ 8 0	16	- 8	25		16.5		1.1	15.2	1	—	—		121	139	255	361	
	LME	81625 N*	4	20	LME	81625 N AJ*	4	19.5	—	—	—																			
12	LME	122232 *	4	41.5	LME	122232 AJ*	4	40.5	LME	122232 OP*	3	32	12		22	0	32	- 200	22.9	- 200	1.3	21	1.5	7.5	78	12	259	298	503	711
	LME	122232 N*	4	40	LME	122232 N AJ*	4	39	LME	122232 N OP*	3	30																		
16	LME	162636 *	4	56.5	LME	162636 AJ*	4	55.5	LME	162636 OP*	3	48	16		26	- 9	36		24.9		1.3	24.9	1.5	10	78		283	325	514	726
	LME	162636 N*	4	55	LME	162636 N AJ*	4	54	LME	162636 N OP*	3	46																		
20	LME	203245 *	5	97	LME	203245 AJ*	5	96	LME	203245 OP*	4	84	20		32		45		31.5		1.6	30.3	2	10	60		562	668	1 010	1 470
	LME	203245 N*	5	91	LME	203245 N AJ*	5	90	LME	203245 N OP*	4	75																		
25	LME	254058 *	6	222	LME	254058 AJ*	6	219	LME	254058 OP*	5	195	25		40	0	58		44.1		1.85	37.5	2	12.5	60	15	920	974	1 780	2 280
	LME	254058 N*	6	215	LME	254058 N AJ*	6	212	LME	254058 N OP*	5	181																		
30	LME	304768 *	6	338	LME	304768 AJ*	6	333	LME	304768 OP*	5	309	30		47	0	68		52.1		1.85	44.5	2	12.5	50		1 350	1 430	2 500	3 200
	LME	304768 N*	6	325	LME	304768 N AJ*	6	320	LME	304768 N OP*	5	272																		
40	LME	406280 *	6	712	LME	406280 AJ*	6	701	LME	406280 OP*	5	665	40		62	0	80	- 300	60.6	- 300	2.15	59	3	16.8	50	17	2 030	2 150	3 620	4 640
	LME	406280 N*	6	705	LME	406280 N AJ*	6	694	LME	406280 N OP*	5	600																		
50	LME	5075100 *	6	1 147	LME	5075100 AJ*	6	1 127	LME	5075100 OP*	5	1 080	50		75	- 13	100		77.6		2.65	72	3	21	50		3 940	4 180	7 130	9 120
	LME	5075100 N*	6	1 130	LME	5075100 N AJ*	6	1 110	LME	5075100 N OP*	5	970																		
60	LME	6090125 *	6	2 051	LME	6090125 AJ*	6	2 001	LME	6090125 OP*	5	1 900	60		90	0	125	- 400	101.7	- 400	3.15	86.5	3	27.2	54	20	4 760	5 040	8 150	10 400
	LME	6090125 N*	6	2 050	LME	6090125 N AJ*	6	2 000	LME	6090125 N OP*	5	1 580																		
80	LME	80120165 *	6	5 140	LME	80120165 AJ*	6	5 000	LME	80120165 OP*	5	4 380	80	+ 16 - 4	120	- 15	165		133.7		4.15	116	3	36.3	54		8 710	9 220	14 500	18 500

Note (1) The width of hub for fixing with circlip should be the value obtained by subtracting a circlip width value times two from the C<sub>1</sub> dimension.

- Remarks 1. High carbon steel-made retainer (shaft diameter 8 mm), and standard type and adjustable clearance type (shaft diameter 12 mm to 60 mm) end plates are fixed with stop ring for holes.  
2. The identification numbers with \* are our semi-standard items.

LMG • LM • LMS

# IKO Linear Bushing With Seal

	Standard type					Adjustable clearance type					Open type								
Shape	LME... UU LME...N UU					LME... UU AJ LME...N UU AJ					LME... UU OP LME...N UU OP								
																			
Shaft diameter	5	8	12	16	20	25	5	8	12	16	20	25	—	—	12	16	20	25	
	30	40	50	60	80	30	40	50	60	80	30	40	50	60	80				

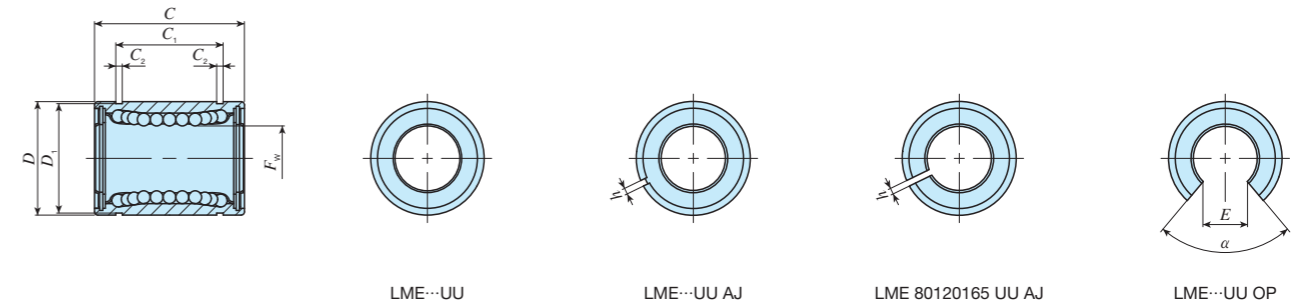

Shaft diameter mm	Identification number										Nominal dimensions and tolerances mm											Eccentricity Maximum μm	Basic dynamic load rating C		Basic static load rating C <sub>0</sub>					
	Standard type		Ball raceway	Mass (Ref.) g	Adjustable clearance type		Ball raceway	Mass (Ref.) g	Open type		Ball raceway	Mass (Ref.) g	F <sub>w</sub>	Dim. Fw tolerance μm	D	Dim. D tolerance μm	C	Dim. C tolerance μm	C <sub>1</sub> ( <sup>1</sup> )	Dim. C <sub>1</sub> tolerance μm	C <sub>2</sub>		D <sub>1</sub>	h	E	α Degree	Load direction A N	Load direction B N	Load direction A N	Load direction B N
5	LME 51222 N UU*	4	11	LME 51222 N UU AJ*	4	9.5	—	—	—	—	—	5		12	0	22		14.5		1.1	11.5	1	—	—	12	90.8	104	219	310	
8	LME 81625 UU*	4	20	—	—	—	—	—	—	—	—	8	+8 0	16	-8	25		16.5		1.1	15.2	1	—	—	12	121	139	255	361	
12	LME 122232 UU*	4	41.5	LME 122232 UU AJ*	4	40.5	LME 122232 UU OP*	3	32	—	—	12		22	0	32	0	22.9	0	1.3	21	1.5	7.5	78	12	259	298	503	711	
16	LME 162636 UU*	4	56.5	LME 162636 UU AJ*	4	55.5	LME 162636 UU OP*	3	48	—	—	16	+9 -1	26	-9	36	-200	24.9	-200	1.3	24.9	1.5	10	78	12	283	325	514	726	
20	LME 203245 UU*	5	97	LME 203245 UU AJ*	5	96	LME 203245 UU OP*	4	84	—	—	20		32		45		31.5		1.6	30.3	2	10	60	12	562	668	1 010	1 470	
25	LME 254058 UU*	6	222	LME 254058 UU AJ*	6	219	LME 254058 UU OP*	5	195	—	—	25	+11 -1	40	0	58		44.1		1.85	37.5	2	12.5	60	15	920	974	1 780	2 280	
30	LME 304768 UU*	6	338	LME 304768 UU AJ*	6	333	LME 304768 UU OP*	5	309	—	—	30		47		68	0	52.1	0	1.85	44.5	2	12.5	50	12	1 350	1 430	2 500	3 200	
40	LME 406280 UU*	6	712	LME 406280 UU AJ*	6	701	LME 406280 UU OP*	5	665	—	—	40		62	0	80	-300	60.6	-300	2.15	59	3	16.8	50	17	2 030	2 150	3 620	4 640	
50	LME 5075100 UU*	6	1 147	LME 5075100 UU AJ*	6	1 127	LME 5075100 UU OP*	5	1 080	—	—	50	+13 -2	75	-13	100		77.6		2.65	72	3	21	50	17	3 940	4 180	7 130	9 120	
60	LME 6090125 UU*	6	2 051	LME 6090125 UU AJ*	6	2 001	LME 6090125 UU OP*	5	1 900	—	—	60		90	0	125	0	101.7	0	3.15	86.5	3	27.2	54	20	4 760	5 040	8 150	10 400	
80	LME80120165 UU*	6	5 030	LME80120165 UU AJ*	6	4 930	LME80120165 UU OP*	5	4 210	—	—	80	+16 -4	120	-15	165	-400	133.7	-400	4.15	116	3	36.3	54	20	8 710	9 220	14 500	18 500	

Notes (1) The width of hub for fixing with circlip should be the value obtained by subtracting a circlip width value times two from the C<sub>1</sub> dimension.

(2) The seal is slightly off from the external cylinder end.

Remarks 1. High carbon steel-made retainer (shaft diameter 8 mm), and standard type and adjustable clearance type (shaft diameter 12 mm to 60 mm) end plates are fixed with stop ring for holes.

2. The identification numbers with \* are our semi-standard items.

LMG • LM • LMS

# IKO Linear Bushing Inch Series

	Standard type				Adjustable clearance type				Open type			
Shape	LMB LMB···N				LMB··· AJ LMB···N AJ				LMB··· OP LMB···N OP			
	Shaft diameter	6.350	9.525	12.700	15.875	6.350	9.525	12.700	15.875	—	—	12.700
19.050		25.400	31.750	38.100	19.050	25.400	31.750	38.100	19.050	25.400	31.750	38.100
50.800		63.500	76.200	101.600	50.800	63.500	76.200	101.600	50.800	63.500	76.200	101.600

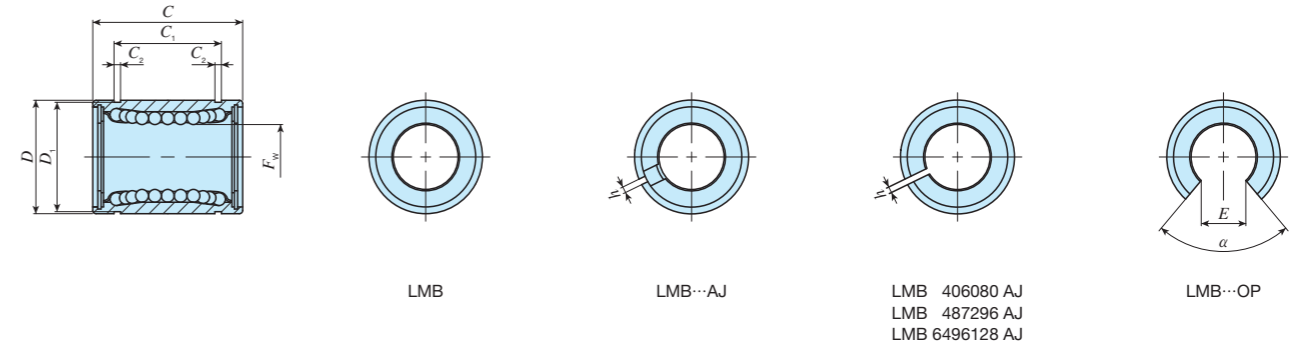

Shaft diameter mm (inch)	Identification number										Nominal dimensions and tolerances inch/mm													Eccentricity Maximum $\mu\text{m}$ P H	Basic dynamic load rating C		Basic static load rating C <sub>0</sub>							
	Standard type		Ball raceway	Mass (Ref.) g	Adjustable clearance type		Ball raceway	Mass (Ref.) g	Open type		Ball raceway	Mass (Ref.) g	F <sub>w</sub>	Dim. F <sub>w</sub> tolerance $\mu\text{m}$		D	Dim. D tolerance $\mu\text{m}$	C	Dim. C tolerance $\mu\text{m}$	C <sub>1</sub> <sup>(1)</sup>	Dim. C <sub>1</sub> tolerance $\mu\text{m}$	C <sub>2</sub>	D <sub>1</sub>		h	E	$\alpha$ Degree	P	H	Load direction A N	Load direction B N	Load direction A N	Load direction B N	
																																		P
6.350 (1/4)	LMB 4812 *	4	10.5	—	—	—	—	—	—	—	—	1/4			1/2	0	3/4			12.98		0.992	11.906	—	—					82.6	94.9	168	238	
	LMB 4812 N*	4	8.5	LMB 4812 N AJ*	4	8	—	—	—	—	—	6.350			12.700	-11	19.050			16.15		0.992	14.935	—	—					94.8	109	174	246	
9.525 (3/8)	LMB 61014 *	4	16.5	—	—	—	—	—	—	—	—	3/8			5/8		7/8			16.15		0.992	14.935	—	—					94.8	109	174	246	
	LMB 61014 N*	4	12.5	LMB 61014 N AJ*	4	12	—	—	—	—	—	9.525	0	0	15.875		22.225			24.46		1.168	20.853	1.5	7.9	80					264	303	505	714
12.700 (1/2)	LMB 81420 *	4	37.5	LMB 81420 AJ*	4	36.5	LMB 81420 OP*	3	28	3	28	1/2	-6	-9	7/8	0	1 1/4	0		28.04		1.422	26.899	1.5	9.5	80					424	488	766	1 080
	LMB 81420 N*	4	37	LMB 81420 N AJ*	4	36	LMB 81420 N OP*	3	27	3	27	12.700			22.225	-13	31.750	-200		29.61		1.422	29.870	1.5	11.1	60					554	659	1 000	1 470
15.875 (5/8)	LMB 101824 *	4	79.6	LMB 101824 AJ*	4	77.6	LMB 101824 OP*	3	64	3	64	5/8			1 1/8		1 1/2		28.04		1.422	26.899	1.5	9.5	80					424	488	766	1 080	
	LMB 101824 N*	4	76	LMB 101824 N AJ*	4	74	LMB 101824 N OP*	3	57	3	57	15.875			28.575		38.100			29.61		1.422	29.870	1.5	11.1	60					554	659	1 000	1 470
19.050 (3/4)	LMB 122026 *	5	99.5	LMB 122026 AJ*	5	97.5	LMB 122026 OP*	4	86	4	86	3/4			1 1/4		1 5/8		29.61		1.422	29.870	1.5	11.1	60					554	659	1 000	1 470	
	LMB 122026 N*	5	95	LMB 122026 N AJ*	5	93	LMB 122026 N OP*	4	76	4	76	19.050	0	0	31.750	0	41.275			44.57		1.727	37.306	1.5	14.3	50					923	978	1 780	2 280
25.400 (1)	LMB 162536 *	6	207	LMB 162536 AJ*	6	205	LMB 162536 OP*	5	190	5	190	1	-7	-10	1 9/16	-16	2 1/4		44.57		1.727	37.306	1.5	14.3	50					923	978	1 780	2 280	
	LMB 162536 N*	6	200	LMB 162536 N AJ*	6	198	LMB 162536 N OP*	5	170	5	170	25.400			39.688		57.150			50.92		1.727	47.904	2.5	15.9	50					1 370	1 450	2 510	3 210
31.750 (1 1/4)	LMB 203242 *	6	434	LMB 203242 AJ*	6	424	LMB 203242 OP*	5	390	5	390	1 1/4			2		2 5/8		50.92		1.727	47.904	2.5	15.9	50					1 370	1 450	2 510	3 210	
	LMB 203242 N*	6	421	LMB 203242 N AJ*	6	411	LMB 203242 N OP*	5	375	5	375	31.750			50.800	0	66.675			61.26		2.184	56.870	3	19.1	50					2 010	2 130	3 610	4 620
38.100 (1 1/2)	LMB 243848 *	6	662	LMB 243848 AJ*	6	652	LMB 243848 OP*	5	610	5	610	1 1/2	0	0	2 3/8	-19	3		61.26		2.184	56.870	3	19.1	50					2 010	2 130	3 610	4 620	
	LMB 243848 N*	6	646	LMB 243848 N AJ*	6	636	LMB 243848 N OP*	5	595	5	595	38.100	-8	-12	60.325		76.200	-300		81.07		2.616	72.085	3	25.4	50					3 960	4 190	7 140	9 130
50.800 (2)	LMB 324864 *	6	1 185	LMB 324864 AJ*	6	1 165	LMB 324864 OP*	5	1 120	5	1 120	2			3		4		81.07		2.616	72.085	3	25.4	50					3 960	4 190	7 140	9 130	
	LMB 324864 N*	6	1 140	LMB 324864 N AJ*	6	1 120	LMB 324864 N OP*	5	980	5	980	50.800			76.200		101.600			100.99		3.048	90.220	3	31.8	50					5 190	5 490	9 090	11 600
63.500 (2 1/2)	LMB 406080 *	6	2 600	LMB 406080 AJ*	6	2 560	LMB 406080 OP*	5	2 230	5	2 230	2 1/2			3 3/4	0	5		100.99		3.048	90.220	3	31.8	50					5 190	5 490	9 090	11 600	
	LMB 406080 N*	6	2 560	LMB 406080 N AJ*	6	2 560	LMB 406080 N OP*	5	2 230	5	2 230	63.500	0	0	95.250	-22	127.000			120.04		3.048	109.474	3	38.1	50					8 620	9 120	14 500	18 500
76.200 (3)	LMB 487296 *	6	4 380	LMB 487296 AJ*	6	4 350	LMB 487296 OP*	5	3 750	5	3 750	3	-9	-15	4 1/2		6		120.04		3.048	109.474	3	38.1	50					8 620	9 120	14 500	18 500	
	LMB 487296 N*	6	4 350	LMB 487296 N AJ*	6	4 350	LMB 487296 N OP*	5	3 750	5	3 750	76.200			114.300		152.400	0		158.95		3.53	145.923	3	50.8	50	20	30			17 000	18 000	28 600	36 500
101.600 (4)	LMB 6496128 *	6	10 200	LMB 6496128 AJ*	6	10 150	LMB 6496128 OP*	5	8 740	5	8 740	4	0	0	6	0	8	-400		158.95		3.53	145.923	3	50.8	50	20	30			17 000	18 000	28 600	36 500
	LMB 6496128 N*	6	10 150	LMB 6496128 N AJ*	6	10 150	LMB 6496128 N OP*	5	8 740	5	8 740	101.600	-10	-20	152.400	-25	203.200			158.95		3.53	145.923	3	50.8	50	20	30			17 000	18 000	28 600	36 500



Notes (1) The width of hub for fixing with circlip should be the value obtained by subtracting a circlip width value times two from the C<sub>1</sub> dimension.

Remarks 1. "P" and "H" in Dim. F<sub>w</sub> tolerance and Eccentricity represent precision and high, respectively.

2. High carbon steel-made retainer (shaft diameter 6.350 mm and 9.525 mm), and standard type and adjustable clearance type (shaft diameter 12.700 mm to 50.800 mm) end plates are fixed with stop ring for holes.

3. The identification numbers with \* are our semi-standard items.

# IKO Linear Bushing Stainless Steel Made

	Standard type					Adjustable clearance type					Open type				
Shape	LM... F LM...N F					LM... FAJ LM...N FAJ					LM... F OP LM...N F OP				
															
Shaft diameter	6	8	10	12	13	6	8	10	12	13	—	—	10	12	13
	16	20	25	30	35	16	20	25	30	35	16	20	25	30	35
	40	50	60			40	50	60			40	50	60		

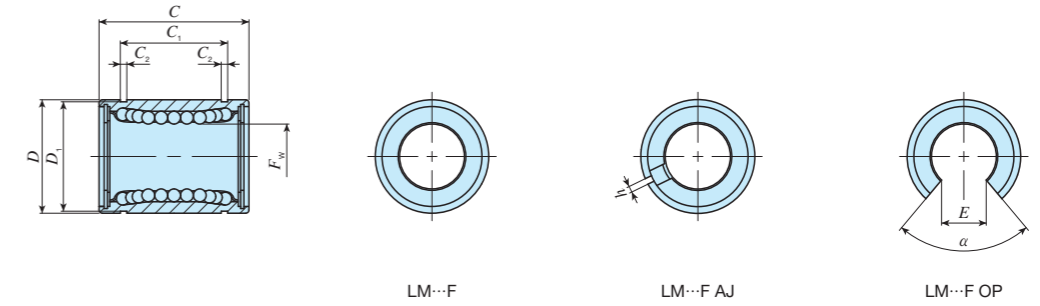

Shaft diameter mm	Identification number										Nominal dimensions and tolerances mm														Eccentricity		Basic dynamic load rating		Basic static load rating				
	Standard type		Ball raceway	Mass (Ref.) g	Adjustable clearance type		Ball raceway	Mass (Ref.) g	Open type		Ball raceway	Mass (Ref.) g	F <sub>w</sub>	Dim. F <sub>w</sub> tolerance μm		D	Dim. D tolerance μm	C	Dim. C tolerance μm	C <sub>1</sub> ( <sup>1</sup> )	Dim. C <sub>1</sub> tolerance μm	C <sub>2</sub>	D <sub>1</sub>	h	E	α	Maximum μm	P	H	Load direction A N	Load direction B N	Load direction A N	Load direction B N
	P	H	P	H	P	H	P	H	P	H	μm	μm		μm	μm																		
6	LM 61219 F	4	8	—	—	—	—	—	—	—	—	6			12		19		13.5		1.1	11.5	—	—	—				80.7	92.7	167	237	
	LM 61219 N F	4	7.6	LM 61219 N F AJ*	4	7.5	—	—	—	—	—	8			15	0 -11	17		11.5		1.1	14.3	—	—	—				87.4	100	160	226	
8	LM 81517 F	4	13	—	—	—	—	—	—	—	—	8			15		24		17.5		1.1	14.3	—	—	—				121	139	255	361	
	LM 81524 F	4	18	—	—	—	—	—	—	—	—	8			15		24		17.5		1.1	14.3	—	—	—				121	139	255	361	
10	LM 101929 F	4	30	—	—	—	—	—	—	—	—	10	0 -6	0 -9	19		29		22		1.3	18	—	—	—	8	12		179	206	354	501	
	LM 101929 N F	4	27.5	LM 101929 N F AJ*	4	26.5	LM 101929 N F OP*	3	18	—	—	12			21	0 -200	30		23		1.3	20	1.5	8	80				259	298	503	711	
12	LM 122130 F	4	29	LM 122130 F AJ*	4	28	LM 122130 F OP*	3	19	—	—	12			21	0 -13	30		23		1.3	20	1.5	8	80				259	298	503	711	
	LM 122130 N F	4	31.5	LM 122130 N F AJ*	4	30.5	LM 122130 N F OP*	3	22	—	—	13			23		32		23		1.3	22	1.5	9	80				266	306	506	716	
13	LM 132332 F	4	43	LM 132332 F AJ*	4	42	LM 132332 F OP*	3	31	—	—	13			23		32		23		1.3	22	1.5	9	80				266	306	506	716	
	LM 132332 N F	4	42.5	LM 132332 N F AJ*	4	41.5	LM 132332 N F OP*	3	31	—	—	16			28		37		26.5		1.6	27	1.5	11	80				426	489	766	1 080	
16	LM 162837 F	4	70	LM 162837 F AJ*	4	69.5	LM 162837 F OP*	3	58	—	—	16			28		37		26.5		1.6	27	1.5	11	80				426	489	766	1 080	
	LM 162837 N F	4	69	LM 162837 N F AJ*	4	68	LM 162837 N F OP*	3	52	—	—	20			32		42		30.5		1.6	30.5	1.5	11	60				562	668	1 010	1 470	
20	LM 203242 F	5	92	LM 203242 F AJ*	5	91	LM 203242 F OP*	4	79	—	—	20			32		42		30.5		1.6	30.5	1.5	11	60				562	668	1 010	1 470	
	LM 203242 N F	5	87	LM 203242 N F AJ*	5	85	LM 203242 N F OP*	4	69	—	—	25	0 -7	0 -10	40	0 -16	59		41		1.85	38	2	12	50	10	15		920	974	1 780	2 280	
25	LM 254059 F	6	226	LM 254059 F AJ*	6	222	LM 254059 F OP*	5	203	—	—	25	0 -7	0 -10	40	0 -16	59		41		1.85	38	2	12	50	10	15		920	974	1 780	2 280	
	LM 254059 N F	6	220	LM 254059 N F AJ*	6	216	LM 254059 N F OP*	5	188	—	—	30			45		64		44.5		1.85	43	2.5	15	50				1 460	1 540	2 780	3 560	
30	LM 304564 F	6	253	LM 304564 F AJ*	6	250	LM 304564 F OP*	5	228	—	—	30			45		64		44.5		1.85	43	2.5	15	50				1 460	1 540	2 780	3 560	
	LM 304564 N F	6	250	LM 304564 N F AJ*	6	245	LM 304564 N F OP*	5	210	—	—	35			52		70		49.5		2.1	49	2.5	17	50				1 610	1 710	3 080	3 940	
35	LM 355270 F	6	387	LM 355270 F AJ*	6	380	LM 355270 F OP*	5	355	—	—	35			52		70		49.5		2.1	49	2.5	17	50				1 610	1 710	3 080	3 940	
	LM 355270 N F	6	380	LM 355270 N F AJ*	6	375	LM 355270 N F OP*	5	335	—	—	40	0 -8	0 -12	60	0 -19	80		60.5		2.1	57	3	20	50	12	20		2 030	2 150	3 620	4 640	
40	LM 406080 F	6	596	LM 406080 F AJ*	6	585	LM 406080 F OP*	5	546	—	—	40	0 -8	0 -12	60	0 -19	80		60.5		2.1	57	3	20	50	12	20		2 030	2 150	3 620	4 640	
	LM 406080 N F	6	585	LM 406080 N F AJ*	6	579	LM 406080 N F OP*	5	500	—	—	50			80		100		74		2.6	76.5	3	25	50				3 940	4 180	7 130	9 120	
50	LM 5080100 F	6	1 615	LM 5080100 F AJ*	6	1 595	LM 5080100 F OP*	5	1 420	—	—	50			80		100		74		2.6	76.5	3	25	50				3 940	4 180	7 130	9 120	
	LM 5080100 N F	6	1 580	LM 5080100 N F AJ*	6	1 560	LM 5080100 N F OP*	5	1 340	—	—	60	0 -9	0 -15	90	0 -22	110		85		3.15	86.5	3	30	50	17	25		4 760	5 040	8 150	10 400	
60	LM 6090110 F	6	1 817	LM 6090110 F AJ*	6	1 788	LM 6090110 F OP*	5	1 650	—	—	60	0 -9	0 -15	90	0 -22	110		85		3.15	86.5	3	30	50	17	25		4 760	5 040	8 150	10 400	
	LM 6090110 N F	6	1 787	LM 6090110 N F AJ*	6	1 757	LM 6090110 N F OP*	5	1 610	—	—																						

Note (1) The width of hub for fixing with circlip should be the value obtained by subtracting a circlip width value times two from the C<sub>1</sub> dimension.

- Remarks 1. "P" and "H" in Dim. F<sub>w</sub> tolerance and Eccentricity represent precision and high, respectively.
- 2. Standard type and adjustable clearance type end plates are fixed with stop ring for holes.
- 3. The identification numbers with \* are our semi-standard items.

LMG • LM • LMS



# IKO Linear Bushing Stainless Steel Made With Seal

Shape	Standard type					Adjustable clearance type					Open type				
	LM... F UU LM... N F UU					LM... F UU AJ LM... N F UU AJ					LM... F UU OP LM... N F UU OP				
Shaft diameter	6	8	10	12	13	6	8	10	12	13	—	—	10	12	13
	16	20	25	30	35	16	20	25	30	35	16	20	25	30	35
	40	50	60			40	50	60			40	50	60		

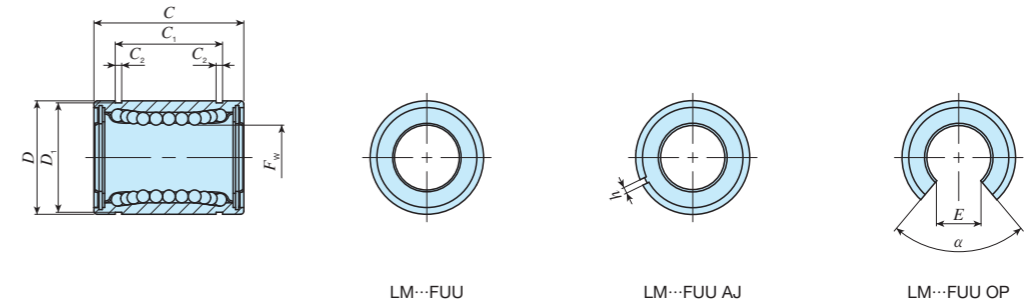



Shaft diameter mm	Identification number										Nominal dimensions and tolerances mm													Eccentricity		Basic dynamic load rating		Basic static load rating					
	Standard type		Ball raceway	Mass (Ref.) g	Adjustable clearance type		Ball raceway	Mass (Ref.) g	Open type		Ball raceway	Mass (Ref.) g	F <sub>w</sub>	Dim. F <sub>w</sub> tolerance μm		D	Dim. D tolerance μm	C	Dim. C tolerance μm	C <sub>1</sub> ( <sup>1</sup> )	Dim. C <sub>1</sub> tolerance μm	C <sub>2</sub>	D <sub>1</sub>	h	E	α	Maximum μm	P	H	Load direction A N	Load direction B N	Load direction A N	Load direction B N
6	LM 61219 F UU	4	8	—	—	—	—	—	—	—	—	6			12		19		13.5		1.1	11.5	—	—	—				80.7	92.7	167	237	
	LM 61219 N F UU	4	7.6	LM 61219 N F UU AJ*	4	7.5	—	—	—	—	—	8			15	0 -11	17		11.5		1.1	14.3	—	—	—				87.4	100	160	226	
8	LM 81517 F UU	4	13	—	—	—	—	—	—	—	—	8			15		24		17.5		1.1	14.3	—	—	—				121	139	255	361	
	LM 81524 F UU	4	18	—	—	—	—	—	—	—	—	8			15		24		17.5		1.1	14.3	—	—	—				121	139	255	361	
10	LM 101929 F UU	4	30	—	—	—	—	—	—	—	—	10	0 -6	0 -9	19		29		22		1.3	18	—	—	—				179	206	354	501	
	LM 101929 N F UU	4	27.5	LM 101929 N F UU AJ*	4	26.5	LM 101929 N F UU OP*	3	18	—	—	10			19		29		22		1.3	18	—	—	—				179	206	354	501	
12	LM 122130 F UU	4	29	LM 122130 F UU AJ*	4	28	LM 122130 F UU OP*	3	19	—	—	12			21	0	30	-200	23	-200	1.3	20	1.5	8	80			259	298	503	711		
	LM 122130 N F UU	4	31.5	LM 122130 N F UU AJ*	4	30.5	LM 122130 N F UU OP*	3	22	—	—	12			21	0	30	-200	23	-200	1.3	20	1.5	8	80			259	298	503	711		
13	LM 132332 F UU	4	43	LM 132332 F UU AJ*	4	42	LM 132332 F UU OP*	3	31	—	—	13			23	-13	32		23		1.3	22	1.5	9	80			266	306	506	716		
	LM 132332 N F UU	4	42.5	LM 132332 N F UU AJ*	4	41.5	LM 132332 N F UU OP*	3	31	—	—	13			23	-13	32		23		1.3	22	1.5	9	80			266	306	506	716		
16	LM 162837 F UU	4	70	LM 162837 F UU AJ*	4	69.5	LM 162837 F UU OP*	3	58	—	—	16			28		37		26.5		1.6	27	1.5	11	80			426	489	766	1 080		
	LM 162837 N F UU	4	69	LM 162837 N F UU AJ*	4	68	LM 162837 N F UU OP*	3	52	—	—	16			28		37		26.5		1.6	27	1.5	11	80			426	489	766	1 080		
20	LM 203242 F UU	5	92	LM 203242 F UU AJ*	5	91	LM 203242 F UU OP*	4	79	—	—	20			32		42		30.5		1.6	30.5	1.5	11	60			562	668	1 010	1 470		
	LM 203242 N F UU	5	87	LM 203242 N F UU AJ*	5	85	LM 203242 N F UU OP*	4	69	—	—	20			32		42		30.5		1.6	30.5	1.5	11	60			562	668	1 010	1 470		
25	LM 254059 F UU	6	226	LM 254059 F UU AJ*	6	222	LM 254059 F UU OP*	5	203	—	—	25	0 -7	0 -10	40	0	59		41		1.85	38	2	12	50	10	15	920	974	1 780	2 280		
	LM 254059 N F UU	6	220	LM 254059 N F UU AJ*	6	216	LM 254059 N F UU OP*	5	188	—	—	25			40	0	59		41		1.85	38	2	12	50	10	15	920	974	1 780	2 280		
30	LM 304564 F UU	6	253	LM 304564 F UU AJ*	6	250	LM 304564 F UU OP*	5	228	—	—	30			45		64		44.5		1.85	43	2.5	15	50			1 460	1 540	2 780	3 560		
	LM 304564 N F UU	6	250	LM 304564 N F UU AJ*	6	245	LM 304564 N F UU OP*	5	210	—	—	30			45		64		44.5		1.85	43	2.5	15	50			1 460	1 540	2 780	3 560		
35	LM 355270 F UU	6	387	LM 355270 F UU AJ*	6	380	LM 355270 F UU OP*	5	355	—	—	35			52		70		49.5		2.1	49	2.5	17	50			1 610	1 710	3 080	3 940		
	LM 355270 N F UU	6	380	LM 355270 N F UU AJ*	6	375	LM 355270 N F UU OP*	5	335	—	—	35			52		70		49.5		2.1	49	2.5	17	50			1 610	1 710	3 080	3 940		
40	LM 406080 F UU	6	596	LM 406080 F UU AJ*	6	585	LM 406080 F UU OP*	5	546	—	—	40	0 -8	0 -12	60	0	80	-300	60.5	-300	2.1	57	3	20	50	12	20	2 030	2 150	3 620	4 640		
	LM 406080 N F UU	6	585	LM 406080 N F UU AJ*	6	579	LM 406080 N F UU OP*	5	500	—	—	40			60	0	80	-300	60.5	-300	2.1	57	3	20	50	12	20	2 030	2 150	3 620	4 640		
50	LM 5080100 F UU	6	1 615	LM 5080100 F UU AJ*	6	1 595	LM 5080100 F UU OP*	5	1 420	—	—	50			80		100		74		2.6	76.5	3	25	50			3 940	4 180	7 130	9 120		
	LM 5080100 N F UU	6	1 580	LM 5080100 N F UU AJ*	6	1 560	LM 5080100 N F UU OP*	5	1 340	—	—	50			80		100		74		2.6	76.5	3	25	50			3 940	4 180	7 130	9 120		
60	LM 6090110 F UU	6	1 817	LM 6090110 F UU AJ*	6	1 788	LM 6090110 F UU OP*	5	1 650	—	—	60	0 -9	0 -15	90	0	110		85		3.15	86.5	3	30	50	17	25	4 760	5 040	8 150	10 400		
	LM 6090110 N F UU	6	1 787	LM 6090110 N F UU AJ*	6	1 757	LM 6090110 N F UU OP*	5	1 610	—	—	60			90	0	110		85		3.15	86.5	3	30	50	17	25	4 760	5 040	8 150	10 400		

Note (1) The width of hub for fixing with circlip should be the value obtained by subtracting a circlip width value times two from the C<sub>1</sub> dimension.

- Remarks 1. "P" and "H" in Dim. F<sub>w</sub> tolerance and Eccentricity represent precision and high, respectively.  
 2. Standard type and adjustable clearance type end plates are fixed with stop ring for holes.  
 3. The identification numbers with \* are our semi-standard items.

LMG • LM • LMS

# IKO Linear Bushing Stainless Steel Made

	Standard type					Adjustable clearance type					Open type				
Shape	LME... F LME... N F					LME... F AJ LME... N F AJ					LME... F OP LME... N F OP				
															
Shaft diameter	5	8	12	16	20	5	8	12	16	20	—	—	12	16	20
	25	30	40	50	60	25	30	40	50	60	25	30	40	50	60

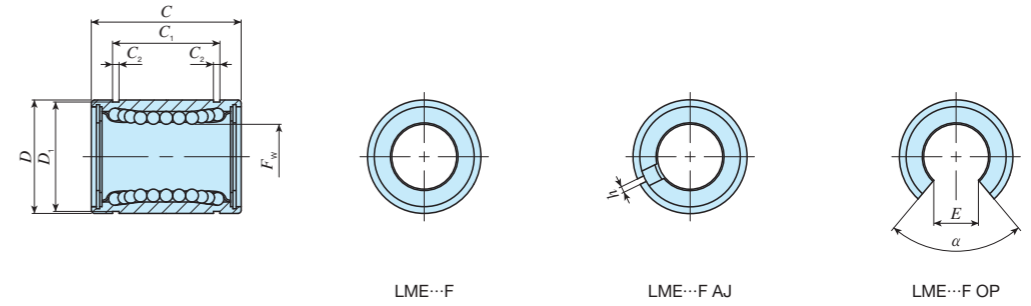



Shaft diameter mm	Identification number										Nominal dimensions and tolerances mm											Eccentricity Maximum μm	Basic dynamic load rating C		Basic static load rating C <sub>0</sub>					
	Standard type		Ball raceway	Mass (Ref.) g	Adjustable clearance type		Ball raceway	Mass (Ref.) g	Open type		Ball raceway	Mass (Ref.) g	F <sub>w</sub>	Dim. F <sub>w</sub> tolerance μm	D	Dim. D tolerance μm	C	Dim. C tolerance μm	C <sub>1</sub> ( <sup>1</sup> )	Dim. C <sub>1</sub> tolerance μm	C <sub>2</sub>		D <sub>1</sub>	h	E	α Degree	Load direction A N	Load direction B N	Load direction A N	Load direction B N
5	LME	51222 N F*	4	11	LME	51222 N F AJ*	4	9.5	—	—	—	5		12	0	22	0	14.5	0	1.1	11.5	1	—	—	12	90.8	104	219	310	
8	LME	81625 F*	4	20	—	—	—	—	—	—	—	8	+ 8 0	16	- 8	25	0	16.5	0	1.1	15.2	—	—	—	12	121	139	255	361	
	LME	81625 N F*	4	20	LME	81625 N F AJ*	4	19.5	—	—	—																			
12	LME	122232 F*	4	41.5	LME	122232 F AJ*	4	40.5	LME	122232 F OP*	3	32	12		22	0	32	0	22.9	0	1.3	21	1.5	7.5	78	12	259	298	503	711
	LME	122232 N F*	4	40	LME	122232 N F AJ*	4	39	LME	122232 N F OP*	3	30																		
16	LME	162636 F*	4	56.5	LME	162636 F AJ*	4	55.5	LME	162636 F OP*	3	48	16	+ 9 - 1	26	- 9	36	-200	24.9	-200	1.3	24.9	1.5	10	78	12	283	325	514	726
	LME	162636 N F*	4	55	LME	162636 N F AJ*	4	54	LME	162636 N F OP*	3	46																		
20	LME	203245 F*	5	97	LME	203245 F AJ*	5	96	LME	203245 F OP*	4	84	20		32		45		31.5		1.6	30.3	2	10	60	12	562	668	1 010	1 470
	LME	203245 N F*	5	91	LME	203245 N F AJ*	5	90	LME	203245 N F OP*	4	75																		
25	LME	254058 F*	6	222	LME	254058 F AJ*	6	219	LME	254058 F OP*	5	195	25	+11 - 1	40	0	58		44.1		1.85	37.5	2	12.5	60	15	920	974	1 780	2 280
	LME	254058 N F*	6	215	LME	254058 N F AJ*	6	212	LME	254058 N F OP*	5	181																		
30	LME	304768 F*	6	338	LME	304768 F AJ*	6	333	LME	304768 F OP*	5	309	30		47		68	0	52.1	0	1.85	44.5	2	12.5	50	17	1 350	1 430	2 500	3 200
	LME	304768 N F*	6	325	LME	304768 N F AJ*	6	320	LME	304768 N F OP*	5	272																		
40	LME	406280 F*	6	712	LME	406280 F AJ*	6	701	LME	406280 F OP*	5	665	40		62	0	80	-300	60.6	-300	2.15	59	3	16.8	50	17	2 030	2 150	3 620	4 640
	LME	406280 N F*	6	705	LME	406280 N F AJ*	6	694	LME	406280 N F OP*	5	600																		
50	LME	5075100 F*	6	1 147	LME	5075100 F AJ*	6	1 127	LME	5075100 F OP*	5	1 080	50	+13 - 2	75	-13	100		77.6		2.65	72	3	21	50	17	3 940	4 180	7 130	9 120
	LME	5075100 N F*	6	1 130	LME	5075100 N F AJ*	6	1 110	LME	5075100 N F OP*	5	970																		
60	LME	6090125 F*	6	2 051	LME	6090125 F AJ*	6	2 001	LME	6090125 F OP*	5	1 900	60		90	0	125	0	101.7	0	3.15	86.5	3	27.2	54	20	4 760	5 040	8 150	10 400
	LME	6090125 N F*	6	2 050	LME	6090125 N F AJ*	6	2 000	LME	6090125 N F OP*	5	1 580																		

Note (1) The width of hub for fixing with circlip should be the value obtained by subtracting a circlip width value times two from the C<sub>1</sub> dimension.

- Remarks 1. Stainless steel-made retainer (shaft diameter 8 mm), and standard type and adjustable clearance type (shaft diameter 12 mm to 60 mm) end plates are fixed with stop ring for holes.  
2. The identification numbers with \* are our semi-standard items.

LMG • LM • LMS

# IKO Linear Bushing Stainless Steel Made With Seal

	Standard type					Adjustable clearance type					Open type									
Shape	LME... F UU LME...N F UU					LME... FUU AJ LME...N FUU AJ					LME... F UU OP LME...N F UU OP									
																				
Shaft diameter	5	8	12	16	20	5	8	12	16	20	—	—	12	16	20	25	30	40	50	60

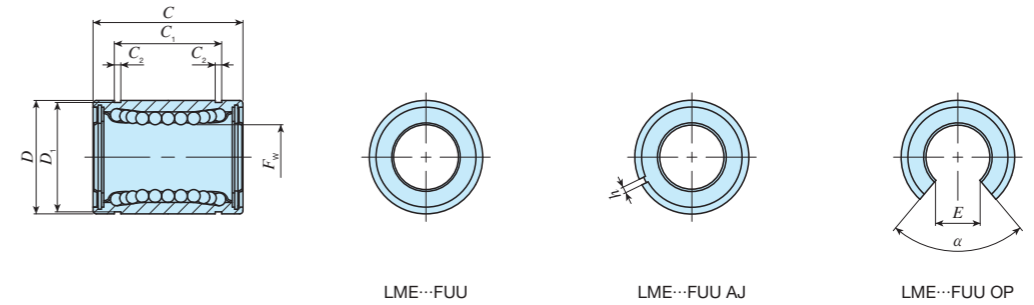

Shaft diameter mm	Identification number										Nominal dimensions and tolerances mm											Eccentricity Maximum μm	Basic dynamic load rating C		Basic static load rating C <sub>0</sub>					
	Standard type		Ball raceway	Mass (Ref.) g	Adjustable clearance type		Ball raceway	Mass (Ref.) g	Open type		Ball raceway	Mass (Ref.) g	F <sub>w</sub>	Dim. Fw tolerance μm	D	Dim. D tolerance μm	C	Dim. C tolerance μm	C <sub>1</sub> ( <sup>1</sup> )	Dim. C <sub>1</sub> tolerance μm	C <sub>2</sub>		D <sub>1</sub>	h	E	α	Load direction A N	Load direction B N	Load direction A N	Load direction B N
5	LME 51222 N F UU*	4	11	LME 51222 N F UU AJ*	4	9.5	—	—	—	—	—	5		12	0	22		14.5		1.1	11.5	1	—	—	12	90.8	104	219	310	
8	LME 81625 F UU*	4	20	—	—	—	—	—	—	—	—	8	+ 8 0	16	- 8	25		16.5		1.1	15.2	1	—	—	12	121	139	255	361	
	LME 81625 N F UU*	4	20	LME 81625 N F UU AJ*	4	19.5	—	—	—	—	—																			
12	LME 122232 F UU*	4	41.5	LME 122232 F UU AJ*	4	40.5	LME 122232 F UU OP*	3	32	3	32	12		22	0	32	0	22.9	0	1.3	21	1.5	7.5	78	12	259	298	503	711	
	LME 122232 N F UU*	4	40	LME 122232 N F UU AJ*	4	39	LME 122232 N F UU OP*	3	30	3	30																			
16	LME 162636 F UU*	4	56.5	LME 162636 F UU AJ*	4	55.5	LME 162636 F UU OP*	3	48	3	48	16	+ 9 - 1	26	- 9	36	- 200	24.9	- 200	1.3	24.9	1.5	10	78	12	283	325	514	726	
	LME 162636 N F UU*	4	55	LME 162636 N F UU AJ*	4	54	LME 162636 N F UU OP*	3	46	3	46																			
20	LME 203245 F UU*	5	97	LME 203245 F UU AJ*	5	96	LME 203245 F UU OP*	4	84	4	84	20		32		45		31.5		1.6	30.3	2	10	60	12	562	668	1 010	1 470	
	LME 203245 N F UU*	5	91	LME 203245 N F UU AJ*	5	90	LME 203245 N F UU OP*	4	75	4	75																			
25	LME 254058 F UU*	6	222	LME 254058 F UU AJ*	6	219	LME 254058 F UU OP*	5	195	5	195	25	+11 - 1	40	0	58		44.1		1.85	37.5	2	12.5	60	15	920	974	1 780	2 280	
	LME 254058 N F UU*( <sup>2</sup> )	6	215	LME 254058 N F UU AJ*( <sup>2</sup> )	6	212	LME 254058 N F UU OP*( <sup>2</sup> )	5	181	5	181																			
30	LME 304768 F UU*	6	338	LME 304768 F UU AJ*	6	333	LME 304768 F UU OP*	5	309	5	309	30		47		68	0	52.1	0	1.85	44.5	2	12.5	50	17	1 350	1 430	2 500	3 200	
	LME 304768 N F UU*	6	325	LME 304768 N F UU AJ*	6	320	LME 304768 N F UU OP*	5	272	5	272																			
40	LME 406280 F UU*	6	712	LME 406280 F UU AJ*	6	701	LME 406280 F UU OP*	5	665	5	665	40		62	0	80	- 300	60.6	- 300	2.15	59	3	16.8	50	17	2 030	2 150	3 620	4 640	
	LME 406280 N F UU*	6	705	LME 406280 N F UU AJ*	6	694	LME 406280 N F UU OP*	5	600	5	600																			
50	LME 5075100 F UU*	6	1 147	LME 5075100 F UU AJ*	6	1 127	LME 5075100 F UU OP*	5	1 080	5	1 080	50	+13 - 2	75	- 13	100		77.6		2.65	72	3	21	50	17	3 940	4 180	7 130	9 120	
	LME 5075100 N F UU*	6	1 130	LME 5075100 N F UU AJ*	6	1 110	LME 5075100 N F UU OP*	5	970	5	970																			
60	LME 6090125 F UU*	6	2 051	LME 6090125 F UU AJ*	6	2 001	LME 6090125 F UU OP*	5	1 900	5	1 900	60		90	0	125	- 400	101.7	- 400	3.15	86.5	3	27.2	54	20	4 760	5 040	8 150	10 400	
	LME 6090125 N F UU*	6	2 050	LME 6090125 N F UU AJ*	6	2 000	LME 6090125 N F UU OP*	5	1 580	5	1 580																			

Notes (<sup>1</sup>) The width of hub for fixing with circlip should be the value obtained by subtracting a circlip width value times two from the C<sub>1</sub> dimension.

(<sup>2</sup>) The seal is slightly off from the external cylinder end.

Remarks 1. Stainless steel-made retainer (shaft diameter 8 mm), and standard type and adjustable clearance type (shaft diameter 12 mm to 60 mm) end plates are fixed with stop ring for holes.

2. The identification numbers with \* are our semi-standard items.

LMG • LM • LMS

# Miniature Linear Bushing

# LMS

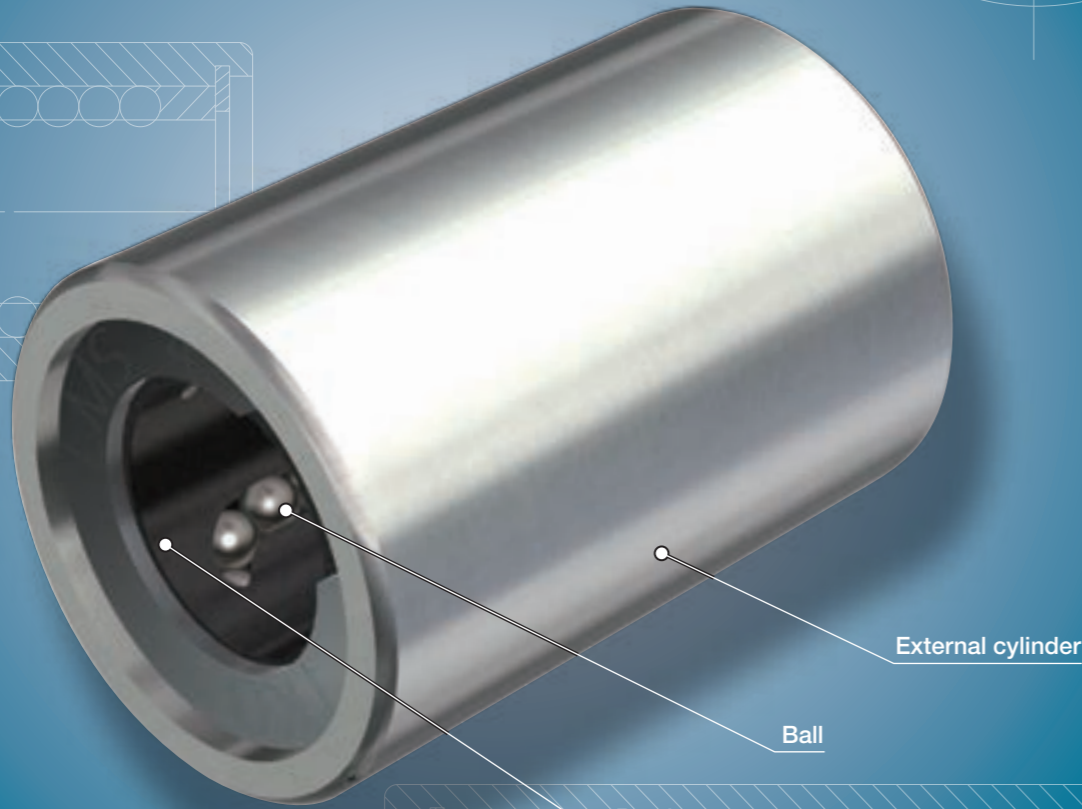
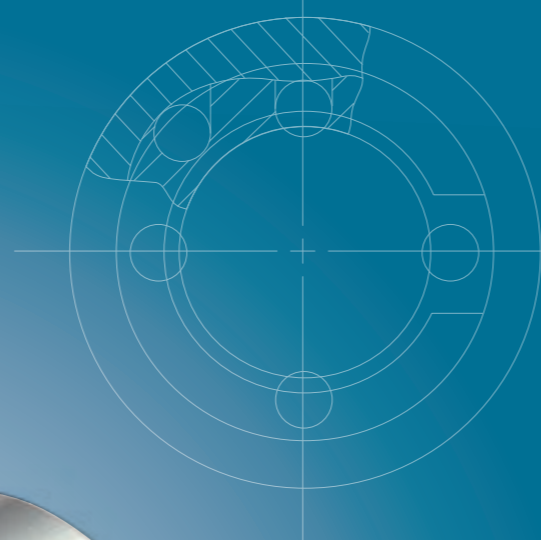

## Points

### 1 Compact design

The ultra-small size allows for compact machine and device design.

### 2 Wide variation

As the lineup of two types of external cylinder length are available, i.e. standard and long, you can select an optimal Linear Bushing for the specifications of your machine and device.

### 3 Stainless steel selections for excellent corrosion resistance

Products made of stainless steel are highly resistant to corrosion, so that they are suitable for applications where rust prevention oil is not preferred, such as in a cleanroom environment.

## Identification Number and Specification

### Example of an identification number

The specification of LMS series is indicated by the identification number. Indicate the identification number, consisting of a model code, dimensions, a material code, a part code, and a classification symbol for each specification to apply.

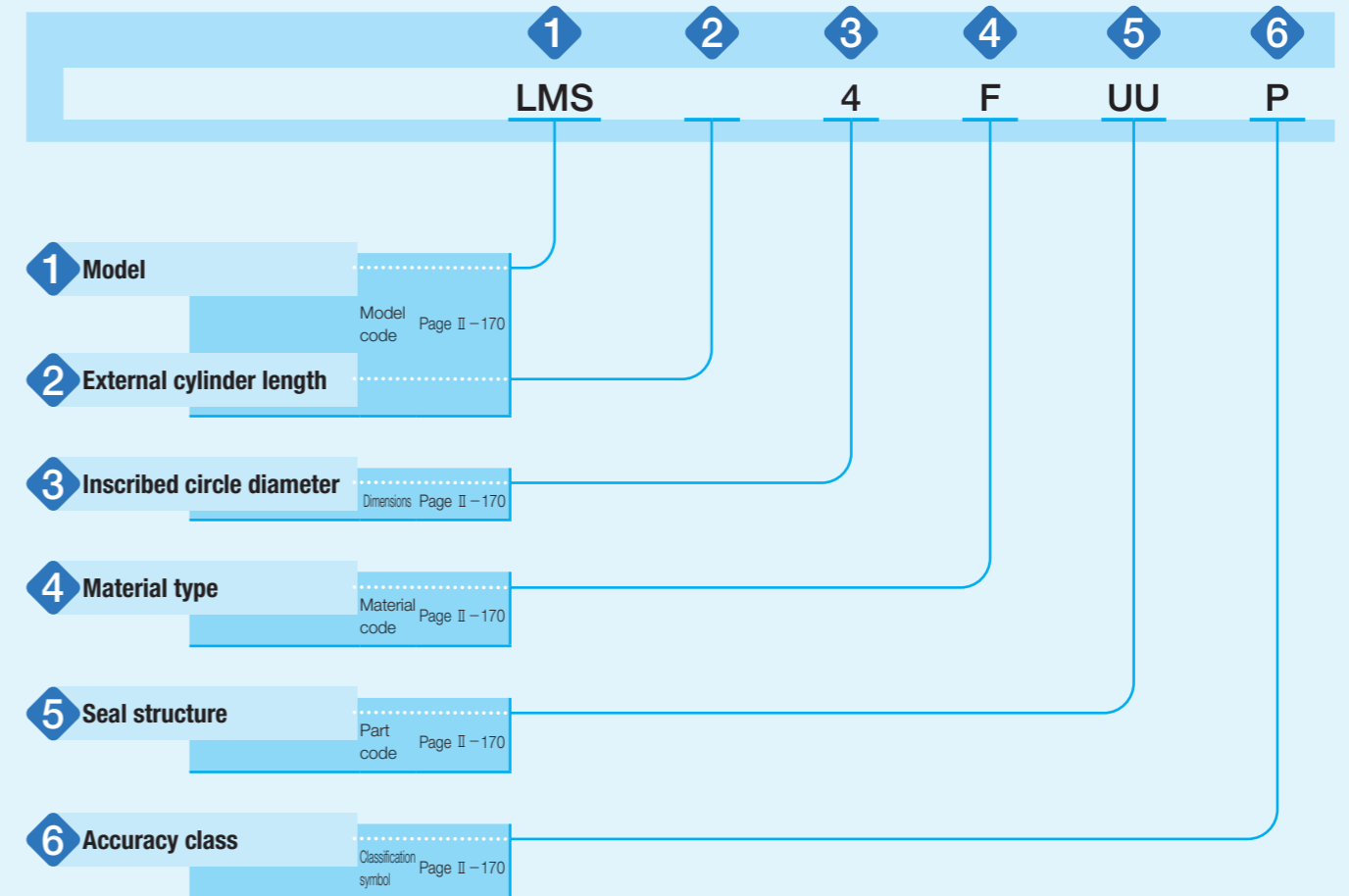

## Identification Number and Specification

<b>1 Model</b>	Miniature Linear Bushing (LMS series)	: LMS	
For applicable models and sizes, see Table 1.			
<b>2 External cylinder length</b>	Standard Long	: No symbol : L	
<b>3 Inscribed circle diameter</b>	Indicate the inscribed circle diameter in mm.		
<b>4 Material type</b>	High carbon steel made Stainless steel made	: No symbol : F	Specify the component part material. For applicable models and sizes, see Table 1.
<b>5 Seal structure</b>	Without seal With two end seals	: No symbol : UU	The models with two end seals incorporate seals with superior dust protection performance for preventing intrusion of foreign substances.
<b>6 Accuracy class</b>	High Precision	: No symbol : P	For details of accuracy, see the dimension table on page II-172. Precision applies only to the standard type. Especially when it is necessary to control clearance with the shaft strictly, the tolerance of inscribed circle diameter can be sorted by 0.002 mm before delivery. Contact IKO for further information.

Table 1 Models and sizes of LMS series

Shape	External cylinder length	Material type	Seal structure	Model	Size		
					3	4	5
	Standard	High carbon steel made	Without seal	LMS	○	○	○
			With two end seals	LMS...UU	○	○	○
		Stainless steel made	Without seal	LMS...F	○	○	○
			With two end seals	LMS...FUU	○	○	○
	Long	High carbon steel made	Without seal	LMSL	○	○	○
			With two end seals	LMSL...UU	○	○	○
		Stainless steel made	Without seal	LMSL...F	○	○	○
			With two end seals	LMSL...FUU	○	○	○

### Relationship between Load Rating and Ball Raceway

The load rating of LMS series varies according to the loading direction and position of ball raceway. The dimension table describes two types of values shown in Fig. 1.1 and Fig. 1.2 according to the loading direction and position of ball raceway.

Fig. 1.1 shows the case where the loading direction and ball raceway position coincides with each other, representing the loading direction A in the dimension table. Generally, this is applied when the ball raceway position cannot be specified to indeterminate direction load or loading direction.

Fig. 1.2 shows the case where the loading direction is positioned between ball raceways, representing the loading direction B in the dimension table. Generally, this can be subjected to load bigger than loading direction A.

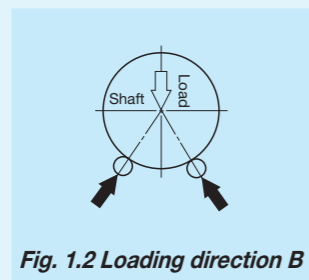
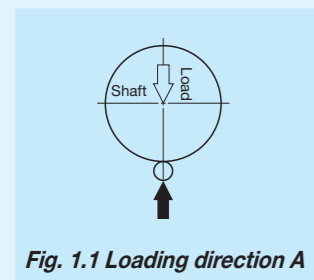

### Lubrication

Grease is not pre-packed in the LMS series, so please perform adequate lubrication as needed.

Both of oil lubrication and grease lubrication are available in the LMS series. For grease lubrication, it is typically applied lightly to the shaft and each row. Use of high-quality lithium-soap base grease is recommended for the grease to use.

### Related Products

#### Shaft for Miniature Linear Bushing

To make full use of performance of the LMS series, we also offer shaft with high accuracy for Miniature Linear Bushing grounded after heat treatment. If you are interested, contact IKO.

### Precaution for Use

#### 1 Fitting of external cylinder

Recommended fit for the LMS series is indicated in Table 2. As the external cylinder is thin, use epoxy type adhesive agent for fixing to the housing hole, instead of press-fitting.

Table 2 Recommended fit (Tolerances of dimensions for shaft and housing hole) unit:  $\mu\text{m}$

Accuracy class	Item	Shaft	Housing hole
High	Shaft	-6	+12
		-14	0
Precision	Housing hole	-4	+8
		-9	0

#### 2 Raceway

LMS series operates with a shaft as a raceway surface, the shaft should be heat-treated and ground. Recommended surface hardness, roughness, and minimum effective hardening depth of shaft are indicated in Table 3.

Table 3 Surface hardness, roughness, and effective hardening depth of shaft

Item	Recommended value	Remark
Surface hardness	58~64HRC	When the surface hardness is low, multiply the load rating by hardness factor <sup>(1)</sup> .
Surface roughness	0.2 $\mu\text{mRa}$ or lower (0.8 $\mu\text{mRy}$ or lower)	-
Effective hardening depth	0.8 mm or higher	-

Note <sup>(1)</sup> For hardness factor, refer to Fig. 3 in page III-5.

#### 3 When accompanied by rotational motion

LMS series units support only linear motion but do not support rotational motion. When performing rotational motion and linear motion of short stroke length, IKO Miniature Stroke Rotary Bushing is recommended to be used.

#### 4 Insertion of shaft

When inserting a shaft to the external cylinder, be careful not to let the shaft pried open as it may cause dropping of balls or deformation of the retainer.

#### 5 Operating temperature

The maximum operating temperature is 120°C and temperature up to 100°C is allowed for continuous operation. When the temperature exceeds 100°C, contact IKO.

## IKO Miniature Linear Bushing

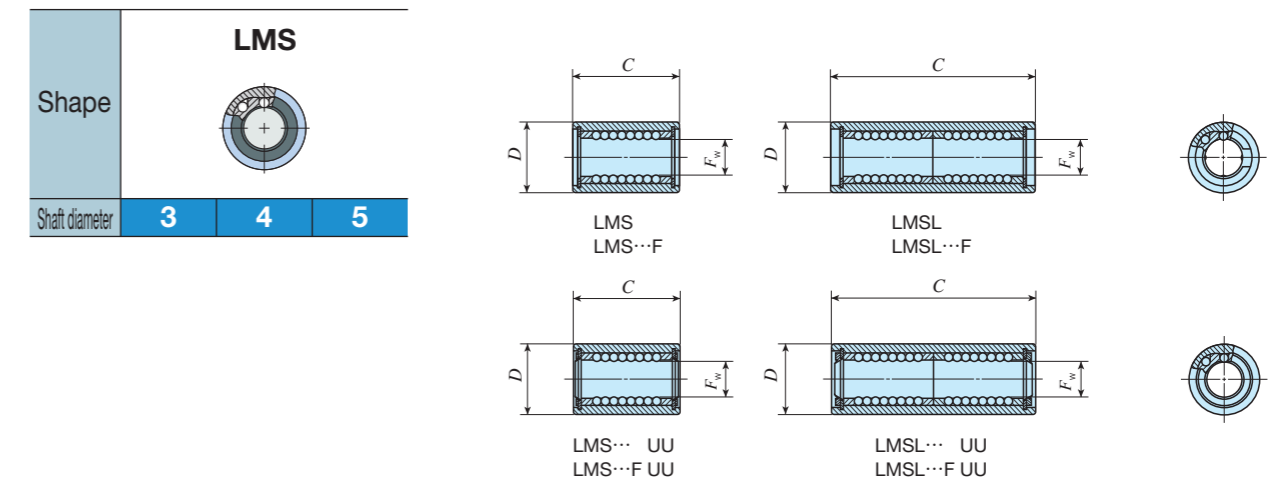

Shaft diameter mm	Identification number	Ball raceway	Mass (Ref.) g	Nominal dimensions and tolerances mm						Eccentricity		Basic dynamic load rating		Basic static load rating				
				Dim. $F_w$ tolerance		Dim. $D$ tolerance		Dim. $C$ tolerance	Maximum		$C$		$C_0$					
				$\mu\text{m}$ P	$\mu\text{m}$ H	$\mu\text{m}$ P	$\mu\text{m}$ H		$\mu\text{m}$ P	$\mu\text{m}$ H	Load direction A N	Load direction B N	Load direction A N	Load direction B N				
3	LMS 3	4	1.8	0	0	-5	-8	0	0	10	0	-120	2	4	48.9	56.1	37.4	52.9
	LMS 3 F																	
	LMS 3 UU																	
	LMS 3 F UU																	
	LMSL 3																	
	LMSL 3 F																	
LMSL 3 UU																		
LMSL 3 F UU																		
4	LMS 4	4	2.8	0	0	-5	-8	0	0	12	0	-120	2	4	58.6	67.3	47.5	67.1
	LMS 4 F																	
	LMS 4 UU																	
	LMS 4 F UU																	
	LMSL 4																	
	LMSL 4 F																	
LMSL 4 UU																		
LMSL 4 F UU																		
5	LMS 5	4	3.8	0	0	-5	-8	0	0	15	0	-120	2	4	135	155	103	146
	LMS 5 F																	
	LMS 5 UU																	
	LMS 5 F UU																	
	LMSL 5																	
	LMSL 5 F																	
LMSL 5 UU																		
LMSL 5 F UU																		

Remark: "P" and "H" in Dim.  $F_w$  tolerance and Eccentricity represent precision and high, respectively.