

General Explanation



Load Rating and Life

Life of linear motion rolling guides

Even in normal operational status, a linear motion rolling guide will reach the end of its life after a certain period of operations. As repeated load is constantly applied onto a raceway and rolling elements of the linear motion rolling guide, this leads to leprous damage (scale-like wear fragments) called fatigue flaking due to rolling contact fatigue of materials, it will be unusable at the end. Total traveling distance before occurrence of this fatigue flaking on a raceway or rolling elements is called the life of linear motion rolling guide. As the life of linear motion rolling guide may vary depending on material fatigue phenomenon, rating life based on statistic calculation is used.

Rating life

Rating life of linear motion rolling guide refers to the total traveling distance ⁽¹⁾ 90% of a group of the same linear motion rolling guide can operate without linear motion rolling guide material damages due to rolling contact fatigue when they are operated individually under the same conditions.

Note ⁽¹⁾ Stroke Rotary Bushing is represented as total number of rotations.

Basic dynamic load rating C

Basic dynamic load rating refers to load with certain direction and size that is logically endurable for rating life indicated in Table 1 when a group of the same linear motion rolling guides is operated individually under the same conditions.

Table 1 Load rating

Series	Rating life
Crossed Roller Way Roller Way & Flat Roller Cage	100×10 ³ m
Linear Slide Unit Linear Ball Spline Linear Bushing	50×10 ³ m
Stroke Rotary Bushing	10 ⁶ rotations

Basic static load rating C_0

Basic static load rating refers to static load generating a certain contact stress at the center of contact parts of the rolling elements and a raceway under maximum load, which is the load at the allowable limit for normal rolling motion. Generally, it is used considering static safety factor.

Allowable load F

Allowable load refers to load of smooth rolling motion on contact surface to which maximum contact stress is applied and the sum of whose elastic deformation of rolling elements and raceway is small. Therefore, use applied load within the allowable load range if very smooth rolling motion and high accuracy are required.

Dynamic torque rating T

Dynamic torque rating refers to a torque with a certain direction and size with which 90% of a group of the same linear ball splines can run 50 × 10³m without material damages due to rolling contact fatigue when they are operated individually.

Static torque rating T_0 Static moment rating T_0, T_x, T_y

Static torque rating and static moment rating refer to static torque or moment load generating a certain level of contact stress at the center of contact parts of rolling elements and a raceway under the maximum load when the torque or moment load (see Fig. 1) are loaded, which is the torque or moment load at the allowable limit for normal rolling motion. Generally, it is used considering static safety factor.

Load direction and load rating

Linear motion rolling guide is used with its load rating corrected in accordance to the load direction. Basic dynamic load rating and basic static load rating indicated in the dimension table should be corrected before use. As the values to be corrected vary depending on series, please see an explanation for each series.

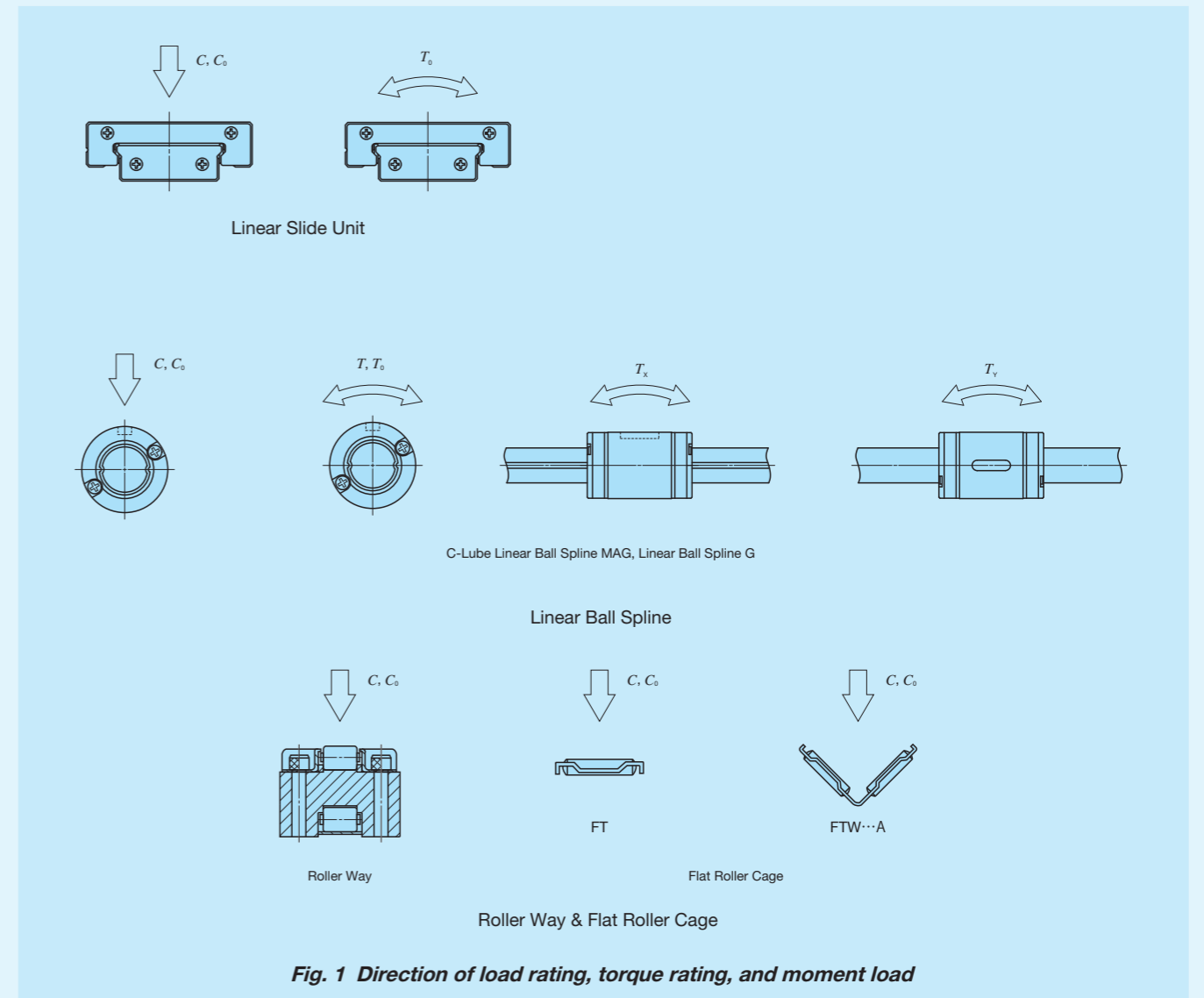

Fig. 1 Direction of load rating, torque rating, and moment load

Remark: For the cases of Crossed Roller Way and Linear Bushing, see an explanation of each series.

Calculating formula of life

Rating life and basic dynamic load rating of a linear motion rolling guide are correlated as indicated in Table 2.1 and Table 2.2.

Table 2.1 Calculating formula of life for each series

Series	Calculating formula of rating life		Code description
	Total traveling distance 10 ³ m	Life length h	
Crossed Roller Way Roller Way & Flat Roller Cage	$L=100\left(\frac{C}{P}\right)^{\frac{10}{3}}$	$L_h = \frac{10^6 L}{2Sn_1 \times 60}$	L : Rating life, 10 ³ m C : Basic dynamic load rating, N T : Dynamic torque rating, N·m P : Dynamic equivalent load (or applied load), N M : Applied torque N·m L _h : Rating life in hours h S : Stroke length mm n ₁ : Number of strokes per minute min ⁻¹
Linear Slide Unit Linear Bushing	$L=50\left(\frac{C}{P}\right)^3$		
Linear Ball Spline	$L=50\left(\frac{C}{P}\right)^3$ $L=50\left(\frac{T}{M}\right)^3$		

Table 2.2 Calculating formula of life for Stroke Rotary Bushing

Series	Calculating formula of rating life		Code description
	Total number of rotation 10 ⁶ rotations	Life length h	
Rotational motion	$L = \left(\frac{C}{P}\right)^3$	$L_h = \frac{10^6 L}{60\sqrt{(D_{PW}n)^2 + (10Sn_1)^2}/D_{PW}}$	L : Rating life, 10 ⁶ rotations C : Basic dynamic load rating, N P : Applied load N L _h : Rating life in hours h n : Rotational speed min ⁻¹ n ₁ : Number of strokes per minute min ⁻¹ S : Stroke length mm D _{PW} : Pitch circle diameter of balls mm (D _{PW} ≈ 1.15F _w) F _w : Inscribed circle diameter mm
Rotational and rotary compound motion			
Rotary and linear motion		$L_h = \frac{10^6 L}{600Sn_1(\pi D_{PW})}$	

Temperature factor

As the allowable contact stress is decreased at operating temperature above 150°C, the basic dynamic load rating should be corrected by the following equation:

$$C_t = f_t C \dots\dots\dots(1)$$

where, C_t : Basic dynamic load rating taking into account temperature increase, N
 f_t : Temperature factor (see Fig. 2)
 C : Basic dynamic load rating, N

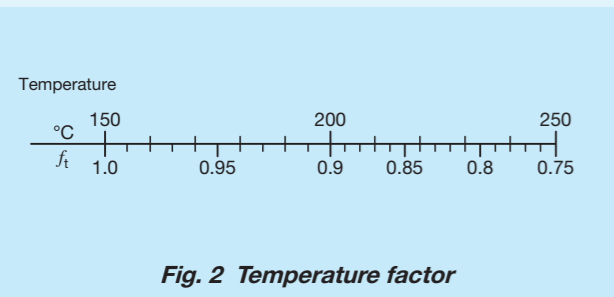

Hardness factor

Hardness of a raceway must be 58 to 64 HRC. When it is lower than 58 HRC, correct basic dynamic load rating by the following equation:

$$C_H = f_H C \dots\dots\dots(2)$$

where, C_H : Basic dynamic load rating taking into account the hardness, N
 f_H : Hardness factor (see Fig. 3)
 C : Basic dynamic load rating, N

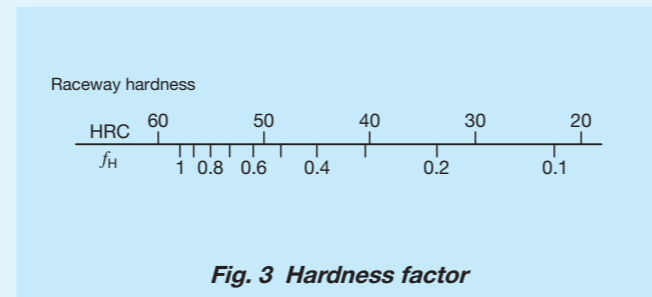

Load factor

Load applied to a linear motion rolling guide can be larger than theoretical load due to machine vibration or shock. Generally, the applied load is obtained by multiplying it by the load factor indicated in Table 3.

Table 3 Load factor

Operating conditions	f _w
Smooth operation free from shock	1 ~1.2
Normal operation	1.2~1.5
Operation with shock load	1.5~3

Static safety factor

Generally, basic static load rating and static moment rating (or static torque rating) is considered as load at the allowable limit for normal rolling motion. However, static safety factor must be considered according to operating conditions and required performance of the linear motion rolling guide.

Static safety factor can be obtained by the following equation and typical values are indicated in Table 4.

Equation (4) is a representative equation for moment load or torque. Static moment rating and maximum moment load in each direction is applied for the calculation.

$$f_s = \frac{C_0}{P_0} \dots\dots\dots(3)$$

$$f_s = \frac{T_0}{M_0} \dots\dots\dots(4)$$

where, f_s : Static safety factor
 C₀ : Basic static load rating, N
 P₀ : Static equivalent load, N
 (Or applied load (maximum load))
 T₀ : Static moment rating, N·m
 (Or static torque rating)
 M₀ : Moment load or torque in each direction, N·m
 (Maximum moment load or maximum torque)

Table 4 Static safety factor

Series	Operational condition and static safety factor		
	Operation with vibration and/or shock	High operating performance	Normal operating conditions
Crossed Roller Way	4 ~6	3~5	2.5~3
Linear Slide Unit	3 ~5	2~4	1 ~3
Linear Ball Spline	5 ~7	4~6	3 ~5
Linear Bushing	2.5	2	1.5
Stroke Rotary Bushing	2.5	2	1.5
Roller Way & Flat Roller Cage	4 ~6	3~5	2.5~3

Preload

Objectives of preload

In some cases, the linear motion rolling guide is used with clearance given to the linear motion rolling guide when light motion with small load is required. However, for some applications it may be used with play in the guiding mechanism removed or with preload to increase rigidity.

Preload is applied to the contact parts of a raceway and rolling elements with internal stress generated in advance. When an external load is applied on the preloaded linear motion rolling guide, shock absorbing with this internal stress makes elastic deformation smaller, and its rigidity is increased. (See Fig.4)

Preload setting

Preload amount is determined by considering the characteristics of the machines or equipments on which the linear motion rolling guide is mounted and the nature of load acting on the linear motion rolling guide. The standard amount of preload for linear motion rolling guides is, in general, approx. 1/3 of load when the rolling elements are balls (steel balls) and approx. 1/2 of load when they are rollers (cylindrical rollers). If the linear motion rolling guides are required to have very high rigidity to withstand vibration or fluctuating load, a larger preload may be applied.

Precaution for preload selection

Even when high rigidity must be required, excessive preload should be avoided, because it will produce an excessive stress between rolling elements and raceways, and eventually result in short life of linear motion rolling guides. It is important to apply a proper amount of preload, considering the operational conditions. When using with a large preload, contact IKO. Linear Bushing and Stroke Rotary Bushing should never be given a large amount of preload.

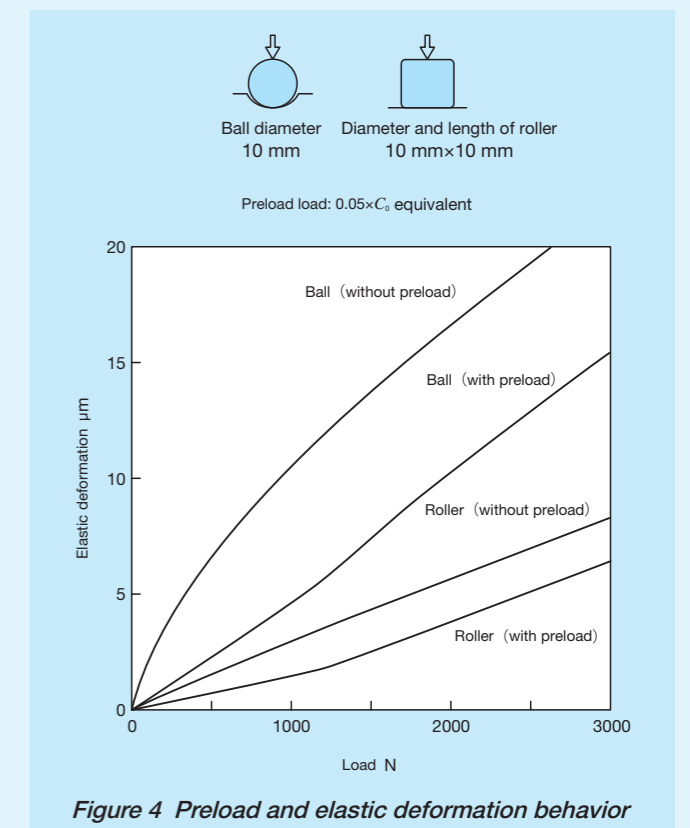

Figure 4 Preload and elastic deformation behavior

1N=0.102kgf=0.2248lbs.
 1mm=0.03937inch

Friction of linear motion rolling guide

The static friction (start-up friction) of linear motion rolling guides is much lower than that of conventional plain guides. Also, the difference between static friction and dynamic friction is small, and frictional resistance varies little when velocity changes. These are excellent features of linear motion rolling guides, and account for their ability to reduce power consumption, suppress operating temperature rise, and increase traveling speed. Since frictional resistance and variation are small, high speed response characteristics to motion commands and high accuracy positioning can be achieved.

Friction coefficient

The frictional resistance of linear motion rolling guides varies with their model, applied load, velocity and characteristics of lubricant. Generally, lubricant or seals are major factors in determining the frictional resistance in light load or high speed operation, while the amount of load is the major factor in heavy load or low speed operation. The frictional resistance of linear motion rolling guides depends on various factors, but generally the following formula is used.

$$F = \mu P \dots\dots\dots(3)$$

where, F : Frictional resistance, N
 μ : Dynamic friction coefficient
 P : Applied load, N

For sealed guides, seal resistance is added to the above value, but this resistance varies greatly depending on the interference amount of seal lip and lubrication conditions. Where the lubrication and mounting condition are correct and the load is moderate, the friction coefficients of linear motion rolling guide in operation are within the range shown in Table 5. Generally, friction coefficient is large under small load.

Table 5 Friction coefficient

Series name	Dynamic friction coefficient μ ⁽¹⁾
Crossed Roller Way	0.0010~0.0030
Linear Slide Unit	0.0010~0.0020
Linear Ball Spline	0.0020~0.0040
Linear Bushing	0.0020~0.0030
Stroke Rotary Bushing	0.0006~0.0012
Roller Way	0.0020~0.0040
Flat Roller Cage	0.0010~0.0030

Note ⁽¹⁾ These friction coefficients do not include seal.

Objectives of lubrication

The objectives of applying lubricant for linear motion rolling guides is to keep raceways, rolling elements, etc. in a linear motion rolling guide from metal contact, and thereby reduce friction and wear preventing heat generation and seizure. When an adequate oil film is formed at the rolling contact area between the raceways and rolling elements, the contact stress due to load can be reduced. To manage the formation of adequate oil film is important for ensuring the reliability of linear motion rolling mechanism.

Selection of lubricant

To obtain the full performance of linear motion rolling guides, it is necessary to select an appropriate lubricant and lubrication method by considering the model, load and velocity of each linear motion rolling guide. However, as compared with plain guides, lubrication of linear motion rolling guides is much simpler. Only a small amount of lubrication oil is needed and replenishment interval is longer, so maintenance can be greatly reduced. Grease and oil are the two most commonly used lubricants for linear motion rolling guides.

Grease lubrication

For linear motion rolling guides, lithium-soap base grease (Consistency No.2 of JIS) is commonly used. For rolling guides operating under heavy load conditions, grease containing extreme pressure additives is recommended. In clean and high-vacuum environments, where low dust generating performance and low vaporization characteristics are required, greases containing a synthetic-base oil or a soap other than the lithium-soap base are used. For applications in these environments, due consideration is necessary to select a grease that is suitable for the operating conditions of linear motion rolling guide and achieves satisfactory lubrication performance at the same time.

Table 6 Pre-packed grease list

Series name	Pre-packed grease
C-Lube Linear Ball Spline MAG Linear Ball Spline G	Alvania EP Grease 2 [Shell Lubricants Japan K.K.]

Grease replenishment interval

The quality of any grease will gradually deteriorate as operating time passes. Therefore, periodic replenishment is necessary. Grease replenishment interval varies depending on the operating conditions. A six month interval is generally recommended, and if the machine operation consists of reciprocating motions with many cycles and long strokes, replenishment every three month is recommended.

In addition, linear motion rolling guides in which the lubrication part "C-Lube" is built deliver long-term maintenance free performance. This eliminates the need for lubrication mechanism and workload which used to be necessary for linear motion rolling guides and significantly reduces maintenance cost.

Grease replenishment method

New grease must be supplied through a grease feed device such as a grease nipple until old grease is discharged. After grease is replenished, running-in is performed and excess grease will be discharged to outside of the linear motion rolling guide. Discharged grease must then be removed before starting the operation. The amount of grease required for standard replenishment is about 1/3 to 1/2 of the free space inside the linear motion rolling guide. When grease is supplied from a grease nipple for the first time, there will be grease lost in the replenishment path. The amount lost should be taken into consideration. Generally, immediately after grease is replenished, frictional resistance tends to increase. If additional running-in is performed for 10 to 20 reciprocating cycles after excess grease is discharged, frictional resistance becomes small and stable. For applications where low frictional resistance is required, the replenishment amount of grease may be reduced, but it must be kept to an appropriate level so as not to give a bad influence on the lubrication performance.

Mixing of different type of grease

Mixing different types of grease may result in changing the properties of base oil, soap base, or additives used, and, in some cases, severely deteriorate the lubrication performance or cause trouble due to chemical changes of additives. Old grease should therefore be removed thoroughly before filling with new grease.

Table 7 Grease brands used in linear motion rolling guide

Brand	Base oil	Thickener	Consistency	Range of operating temperature ⁽²⁾ °C	Usage
Alvania EP Grease 2	[Shell Lubricants Japan K.K.] Mineral oil	Lithium	284	-20~110	General application with extreme-pressure additive
Alvania Grease S2	[Shell Lubricants Japan K.K.] Mineral oil	Lithium	283	-25~120	General application
Multemp PS No.2	[KYODO YUSHI CO., LTD.] Synthetic oil, Mineral oil	Lithium	275	-50~130	General application
IKO Low Dust-Generation Grease for Clean Environment CG2	[NIPPON THOMPSON CO., LTD.] Synthetic oil	Urea	280	-40~200	For clean environment Long life
IKO Low Dust-Generation Grease for Clean Environment CGL	[NIPPON THOMPSON CO., LTD.] Synthetic oil, Mineral oil	Lithium / Calcium	225	-30~120	For clean environment Low sliding
Klüberalfa GR Y-VAC3 ⁽¹⁾	[NOK KLUEBER] Synthetic oil	Ethylene tetra-fluoride	No.3	-20~250	For vacuum
IKO Anti-Fretting Grease AF2	[NIPPON THOMPSON CO., LTD.] Synthetic oil	Urea	285	-50~170	Fretting-proof
6459 Grease N	[Shell Lubricants Japan K.K.] Mineral oil	Poly-urea	305	-	Fretting-proof

Notes ⁽¹⁾ Set replenishment intervals to short.

⁽²⁾ The Ranges of operating temperature are quoted from the grease manufacturer's cataloged values, but do not guarantee regular use under high temperature environment.

Remarks Check with the chosen grease manufacturer's catalog before use.
 For grease for applications other than those listed, please contact IKO.

Oil lubrication

For oil lubrication, heavy load requires high oil viscosity and high velocity requires low oil viscosity. Generally, for linear motion rolling guides operating under heavy load, lubrication oil with a viscosity of about 68 mm²/s is used. For linear motion rolling guides under light load at high speed operation, lubrication oil with a viscosity of about 13 mm²/s is used.

Lubrication part "C-Lube"

C-Lube Linear Ball Spline MAG has built-in lubrication part, "C-Lube".

C-Lube is a porous resin with molding formed fine resin powder. It is a lubrication part impregnated with a large amount of lubrication oil in its open pores by capillary inside. Lubrication oil is supplied directly to balls (steel balls), not to the spline shaft. When the balls have contact with C-Lube built in the external cylinder, lubrication oil is supplied to the surface of the balls. As the steel balls circulate, the lubricant is distributed to the loading area along the track rail. This results in adequate lubrication oil being properly maintained in the loading area and lubrication performance will last for a long time.

The surface of C-Lube is always covered with the lubrication oil. Lubrication oil is continuously supplied to the surface of steel balls by surface tension in the contact of C-Lube surface and steel balls.

Precaution for Use

Cleaning and removing fat

Never clean a linear motion rolling guide that has integrated C-lube with organic solvents or white kerosene with fat removing properties.

Precautions regarding oil components

Rust prevention oil or grease is used for the linear motion rolling guide. Therefore, oil may drip or spatter depending on the operating conditions. Consider installing a shielding plate if necessary.

Storage

Store the linear motion rolling guide horizontally indoors in the IKO packing and packaging provided. Avoid high temperature, low temperature and high humidity. In products pre-packed with lubricant, the lubricant will deteriorate over time if products are stored for a long time. Be sure to reapply lubricant before use.

Statements

● Unit Conversion Rate Table

SI, CGS series and gravity system unit cross-reference table

Amount Unit system	Length	Mass	Time	Acceleration	Force	Stress and pressure
SI	m	kg	s	m/s ²	N	Pa
CGS series	cm	g	s	Gal	dyn	dyn/cm ²
Gravity system	m	kgf·s ² /m	s	m/s ²	kgf	kgf/m ²

SI unit conversion

Amount	Unit name	Code	SI conversion rate	SI unit name	Code
Angle	D	°	$\pi/180$	Radian	rad
	Min	'	$\pi/10\ 800$		
	Sec	"	$\pi/648\ 000$		
Length	Meter	m	1	Meter	m
	Micron	μ	10^{-6}		
	Angstrom	Å	10^{-10}		
	X ray unit		$\approx 1.002\ 08 \times 10^{-13}$		
	Nautical mile	n mile	1852		
Area	Square meter	m ²	1	Square meter	m ²
	Are	a	10^2		
	Hectare	ha	10^4		
Volume	Cubic meter	m ³	1	Cubic meter	m ³
	Liter	l, L	10^{-3}		
Mass	Kilogram	kg	1	Kilogram	kg
	Ton	t	10^3		
	Atomic mass unit	u	$\approx 1.660\ 57 \times 10^{-27}$		
Time	Sec	s	1	Sec	s
	Min	min	60		
	Hr	h	3 600		
	Day	d	86 400		
Velocity	Meter per second	m/s	1	Meter per second	m/s
	Knot	kn	$1\ 852/3\ 600$		
Frequency and vibration	Number of cycle	s ⁻¹	1	Hertz	Hz
Number of rotations	Rotation per minute	min ⁻¹	1/60	Per second	s ⁻¹
Angular velocity	Radian per second	rad/s	1	Radian per second	rad/s
Acceleration	Meter per second	m/s ²	1	Meter per second	m/s ²
	G	G	9.806 65		
Force	Weight in kg	kgf	9.806 65	Newton	N
	Weight in ton	tf	9 806.65		
	Dyne	dyn	10^{-5}		
Force moment load	Weight in kg meter	kgf·m	9.806 65	Newton meter	N·m
Stress and pressure	Weight in kg per square meter	kgf/m ²	9.806 65	Pascal	Pa
	Weight in kg per square cm	kgf/cm ²	$9.806\ 65 \times 10^4$		
	Weight in kg per square mm	kgf/mm ²	$9.806\ 65 \times 10^6$		

Energy	Power	Temperature	Viscosity	Kinetic viscosity	Flux	Flux density	Magnetic field intensity
J	W	K	Pa·s	m ² /s	Wb	T	A/m
erg	erg/s	°C	P	St	Mx	Gs	Oe
kgf·m	kgf·m/s	°C	kgf·s/m ²	m ² /s	—	—	—

Amount	Unit name	Code	SI conversion rate	SI unit name	Code
Pressure	Meter water column	mH ₂ O	9 806.65	Pascal	Pa
	millimeter of mercury column	mmHg	$101\ 325/760$		
	Torr	Torr	$101\ 325/760$		
	Air pressure	atm	101 325		
	Bar	bar	10^5		
Energy	Erg	erg	10^{-7}	Joule	J
	IT calorie	cal _{IT}	4.186 8		
	Weight in kg meter	kgf·m	9.806 65		
	Kilowatt per hour	kW·h	3.600×10^6		
	French horse-power per hour	PS·h	$\approx 2.647\ 79 \times 10^6$		
Electron volt	eV	$\approx 1.602\ 19 \times 10^{-19}$			
Power and motivity	Watt	W	1	Watt	W
	French horse-power	PS	≈ 735.5		
	Weight in kg meter per second	kgf·m/s	9.806 65		
Viscosity	Poise	P	10^{-1}	Pascal second	Pa·s
	Centipoise	cP	10^{-3}		
	Weight in kg second per square meter	kgf·s/m ²	9.806 65		
Kinetic viscosity	Stokes	St	10^{-4}	Square meter per second	m ² /s
	Centistokes	cSt	10^{-6}		
Temperature	D	°C	+273.15	Kelvin	K
Radioactivity	Curie	Ci	3.7×10^{10}	Becquerel	Bq
Exposure radiation dose	Roentgen	R	2.58×10^{-4}	Coulomb per kg	C/kg
Absorbed dose	Rad	rad	10^{-2}	Gray	Gy
	Dose equivalent	Rem	10^{-2}	Sievert	Sv
Flux	Maxwell	Mx	10^{-8}	Weber	Wb
Flux density	Gamma	γ	10^{-9}	Tesla	T
	Gauss	Gs	10^{-4}		
Magnetic field intensity	Oersted	Oe	$10^3/4\pi$	Ampere per meter	A/m
Electric charge	Coulomb	C	1	Coulomb	C
Electric potential difference	Volt	V	1	Volt	V
Capacitance	Farad	F	1	Farad	F
(Electric) Resistance	Ohm	Ω	1	Ohm	Ω
(Electric) Conductance	Siemens	S	1	Siemens	S
Inductance	Henry	H	1	Henry	H
Current	Ampere	A	1	Ampere	A

● Inch-mm Conversion Table

1 inch=25.4mm

inch		0"	1"	2"	3"	4"	5"	6"	7"	8"
Fractional number	Decimal number									
1 / 64"	0.015625	0.397	25.797	51.197	76.597	101.997	127.397	152.797	178.197	203.597
1 / 32"	0.031250	0.794	26.194	51.594	76.994	102.394	127.794	153.194	178.594	203.994
3 / 64"	0.046875	1.191	26.591	51.991	77.391	102.791	128.191	153.591	178.991	204.391
1 / 16"	0.062500	1.588	26.988	52.388	77.788	103.188	128.588	153.988	179.388	204.788
5 / 64"	0.078125	1.984	27.384	52.784	78.184	103.584	128.984	154.384	179.784	205.184
3 / 32"	0.093750	2.381	27.781	53.181	78.581	103.981	129.381	154.781	180.181	205.581
7 / 64"	0.109375	2.778	28.178	53.578	78.978	104.378	129.778	155.178	180.578	205.978
1 / 8"	0.125000	3.175	28.575	53.975	79.375	104.775	130.175	155.575	180.975	206.375
9 / 64"	0.140625	3.572	28.972	54.372	79.772	105.172	130.572	155.972	181.372	206.772
5 / 32"	0.156250	3.969	29.369	54.769	80.169	105.569	130.969	156.369	181.769	207.169
11 / 64"	0.171875	4.366	29.766	55.166	80.566	105.966	131.366	156.766	182.166	207.566
3 / 16"	0.187500	4.762	30.162	55.562	80.962	106.362	131.762	157.162	182.562	207.962
13 / 64"	0.203125	5.159	30.559	55.959	81.359	106.759	132.159	157.559	182.959	208.359
7 / 32"	0.218750	5.556	30.956	56.356	81.756	107.156	132.556	157.956	183.356	208.756
15 / 64"	0.234375	5.953	31.353	56.753	82.153	107.553	132.953	158.353	183.753	209.153
1 / 4"	0.250000	6.350	31.750	57.150	82.550	107.950	133.350	158.750	184.150	209.550
17 / 64"	0.265625	6.747	32.147	57.547	82.947	108.347	133.747	159.147	184.547	209.947
9 / 32"	0.281250	7.144	32.544	57.944	83.344	108.744	134.144	159.544	184.944	210.344
19 / 64"	0.296875	7.541	32.941	58.341	83.741	109.141	134.541	159.941	185.341	210.741
5 / 16"	0.312500	7.938	33.338	58.738	84.138	109.538	134.938	160.338	185.738	211.138
21 / 64"	0.328125	8.334	33.734	59.134	84.534	109.934	135.334	160.734	186.134	211.534
11 / 32"	0.343750	8.731	34.131	59.531	84.931	110.331	135.731	161.131	186.531	211.931
23 / 64"	0.359375	9.128	34.528	59.928	85.328	110.728	136.128	161.528	186.928	212.328
3 / 8"	0.375000	9.525	34.925	60.325	85.725	111.125	136.525	161.925	187.325	212.725
25 / 64"	0.390625	9.922	35.322	60.722	86.122	111.522	136.922	162.322	187.722	213.122
13 / 32"	0.406250	10.319	35.719	61.119	86.519	111.919	137.319	162.719	188.119	213.519
27 / 64"	0.421875	10.716	36.116	61.516	86.916	112.316	137.716	163.116	188.516	213.916
7 / 16"	0.437500	11.112	36.512	61.912	87.312	112.712	138.112	163.512	188.912	214.312
29 / 64"	0.453125	11.509	36.909	62.309	87.709	113.109	138.509	163.909	189.309	214.709
15 / 32"	0.468750	11.906	37.306	62.706	88.106	113.506	138.906	164.306	189.706	215.106
31 / 64"	0.484375	12.303	37.703	63.103	88.503	113.903	139.303	164.703	190.103	215.503
1 / 2"	0.500000	12.700	38.100	63.500	88.900	114.300	139.700	165.100	190.500	215.900

1 inch=25.4mm

inch		0"	1"	2"	3"	4"	5"	6"	7"	8"
Fractional number	Decimal number									
33 / 64"	0.515625	13.097	38.497	63.897	89.297	114.697	140.097	165.497	190.897	216.297
17 / 32"	0.531250	13.494	38.894	64.294	89.694	115.094	140.494	165.894	191.294	216.694
35 / 64"	0.546875	13.891	39.291	64.691	90.091	115.491	140.891	166.291	191.691	217.091
9 / 16"	0.562500	14.288	39.688	65.088	90.488	115.888	141.288	166.688	192.088	217.488
37 / 64"	0.578125	14.684	40.084	65.484	90.884	116.284	141.684	167.084	192.484	217.884
19 / 32"	0.593750	15.081	40.481	65.881	91.281	116.681	142.081	167.481	192.881	218.281
39 / 64"	0.609375	15.478	40.878	66.278	91.678	117.078	142.478	167.878	193.278	218.678
5 / 8"	0.625000	15.875	41.275	66.675	92.075	117.475	142.875	168.275	193.675	219.075
41 / 64"	0.640625	16.272	41.672	67.072	92.472	117.872	143.272	168.672	194.072	219.472
21 / 32"	0.656250	16.669	42.069	67.469	92.869	118.269	143.669	169.069	194.469	219.869
43 / 64"	0.671875	17.066	42.466	67.866	93.266	118.666	144.066	169.466	194.866	220.266
11 / 16"	0.687500	17.462	42.862	68.262	93.662	119.062	144.462	169.862	195.262	220.662
45 / 64"	0.703125	17.859	43.259	68.659	94.059	119.459	144.859	170.259	195.659	221.059
23 / 32"	0.718750	18.256	43.656	69.056	94.456	119.856	145.256	170.656	196.056	221.456
47 / 64"	0.734375	18.653	44.053	69.453	94.853	120.253	145.653	171.053	196.453	221.853
3 / 4"	0.750000	19.050	44.450	69.850	95.250	120.650	146.050	171.450	196.850	222.250
49 / 64"	0.765625	19.447	44.847	70.247	95.647	121.047	146.447	171.847	197.247	222.647
25 / 32"	0.781250	19.844	45.244	70.644	96.044	121.444	146.844	172.244	197.644	223.044
51 / 64"	0.796875	20.241	45.641	71.041	96.441	121.841	147.241	172.641	198.041	223.441
13 / 16"	0.812500	20.638	46.038	71.438	96.838	122.238	147.638	173.038	198.438	223.838
53 / 64"	0.828125	21.034	46.434	71.834	97.234	122.634	148.034	173.434	198.834	224.234
27 / 32"	0.843750	21.431	46.831	72.231	97.631	123.031	148.431	173.831	199.231	224.631
55 / 64"	0.859375	21.828	47.228	72.628	98.028	123.428	148.828	174.228	199.628	225.028
7 / 8"	0.875000	22.225	47.625	73.025	98.425	123.825	149.225	174.625	200.025	225.425
57 / 64"	0.890625	22.622	48.022	73.422	98.822	124.222	149.622	175.022	200.422	225.822
29 / 32"	0.906250	23.019	48.419	73.819	99.219	124.619	150.019	175.419	200.819	226.219
59 / 64"	0.921875	23.416	48.816	74.216	99.616	125.016	150.416	175.816	201.216	226.616
15 / 16"	0.937500	23.812	49.212	74.612	100.012	125.412	150.812	176.212	201.612	227.012
61 / 64"	0.953125	24.209	49.609	75.009	100.409	125.809	151.209	176.609	202.009	227.409
31 / 32"	0.968750	24.606	50.006	75.406	100.806	126.206	151.606	177.006	202.406	227.806
63 / 64"	0.984375	25.003	50.403	75.803	101.203	126.603	152.003	177.403	202.803	228.203

● Hardness Conversion Table (Reference)

Rockwell C scale hardness Load 1471N HRC	Vickers hardness HV	Brinell hardness		Rockwell hardness		Shore hardness HS
		Standard ball	Tungsten Carbide ball	A scale	B scale	
				Load 588.4N Diamond circular cone	Load 980.7N Diameter 1/16in ball	
68	940	—	—	85.6	—	97
67	900	—	—	85.0	—	95
66	865	—	—	84.5	—	92
65	832	—	(739)	83.9	—	91
64	800	—	(722)	83.4	—	88
63	772	—	(705)	82.8	—	87
62	746	—	(688)	82.3	—	85
61	720	—	(670)	81.8	—	83
60	697	—	(654)	81.2	—	81
59	674	—	(634)	80.7	—	80
58	653	—	615	80.1	—	78
57	633	—	595	79.6	—	76
56	613	—	577	79.0	—	75
55	595	—	560	78.5	—	74
54	577	—	543	78.0	—	72
53	560	—	525	77.4	—	71
52	544	(500)	512	76.8	—	69
51	528	(487)	496	76.3	—	68
50	513	(475)	481	75.9	—	67
49	498	(464)	469	75.2	—	66
48	484	451	455	74.7	—	64
47	471	442	443	74.1	—	63
46	458	432	432	73.6	—	62
45	446	421	421	73.1	—	60
44	434	409	409	72.5	—	58
43	423	400	400	72.0	—	57
42	412	390	390	71.5	—	56
41	402	381	381	70.9	—	55
40	392	371	371	70.4	—	54
39	382	362	362	69.9	—	52

Rockwell C scale hardness Load 1471N HRC	Vickers hardness HV	Brinell hardness		Rockwell hardness		Shore hardness HS
		Standard ball	Tungsten Carbide ball	A scale	B scale	
				Load 588.4N Diamond circular cone	Load 980.7N Diameter 1/16in ball	
38	372	353	353	69.4	—	51
37	363	344	344	68.9	—	50
36	354	336	336	68.4	(109.0)	49
35	345	327	327	67.9	(108.5)	48
34	336	319	319	67.4	(108.0)	47
33	327	311	311	66.8	(107.5)	46
32	318	301	301	66.3	(107.0)	44
31	310	294	294	65.8	(106.0)	43
30	302	286	286	65.3	(105.5)	42
29	294	279	279	64.7	(104.5)	41
28	286	271	271	64.3	(104.0)	41
27	279	264	264	63.8	(103.0)	40
26	272	258	258	63.3	(102.5)	38
25	266	253	253	62.8	(101.5)	38
24	260	247	247	62.4	(101.0)	37
23	254	243	243	62.0	100.0	36
22	248	237	237	61.5	99.0	35
21	243	231	231	61.0	98.5	35
20	238	226	226	60.5	97.8	34
(18)	230	219	219	—	96.7	33
(16)	222	212	212	—	95.5	32
(14)	213	203	203	—	93.9	31
(12)	204	194	194	—	92.3	29
(10)	196	187	187	—	90.7	28
(8)	188	179	179	—	89.5	27
(6)	180	171	171	—	87.1	26
(4)	173	165	165	—	85.5	25
(2)	166	158	158	—	83.5	24
(0)	160	152	152	—	81.7	24

● Tolerances of Shaft Dimensions

Classification of diameter mm		b12		c12		d6		e6		e12		f5		f6		g5	
Above	Below	H	L	H	L	H	L	H	L	H	L	H	L	H	L	H	L
—	3	-140	-240	-60	-160	-20	-26	-14	-20	-14	-114	-6	-10	-6	-12	-2	-6
3	6	-140	-260	-70	-190	-30	-38	-20	-28	-20	-140	-10	-15	-10	-18	-4	-9
6	10	-150	-300	-80	-230	-40	-49	-25	-34	-25	-175	-13	-19	-13	-22	-5	-11
10	18	-150	-330	-95	-275	-50	-61	-32	-43	-32	-212	-16	-24	-16	-27	-6	-14
18	30	-160	-370	-110	-320	-65	-78	-40	-53	-40	-250	-20	-29	-20	-33	-7	-16
30	40	-170	-420	-120	-370	-80	-96	-50	-66	-50	-300	-25	-36	-25	-41	-9	-20
40	50	-180	-430	-130	-380	-80	-96	-50	-66	-50	-300	-25	-36	-25	-41	-9	-20
50	65	-190	-490	-140	-440	-100	-119	-60	-79	-60	-360	-30	-43	-30	-49	-10	-23
65	80	-200	-500	-150	-450	-100	-119	-60	-79	-60	-360	-30	-43	-30	-49	-10	-23
80	100	-220	-570	-170	-520	-120	-142	-72	-94	-72	-422	-36	-51	-36	-58	-12	-27
100	120	-240	-590	-180	-530	-120	-142	-72	-94	-72	-422	-36	-51	-36	-58	-12	-27
120	140	-260	-660	-200	-600	-145	-170	-85	-110	-85	-485	-43	-61	-43	-68	-14	-32
140	160	-280	-680	-210	-610	-145	-170	-85	-110	-85	-485	-43	-61	-43	-68	-14	-32
160	180	-310	-710	-230	-630	-145	-170	-85	-110	-85	-485	-43	-61	-43	-68	-14	-32
180	200	-340	-800	-240	-700	-170	-199	-100	-129	-100	-560	-50	-70	-50	-79	-15	-35
200	225	-380	-840	-260	-720	-170	-199	-100	-129	-100	-560	-50	-70	-50	-79	-15	-35
225	250	-420	-880	-280	-740	-170	-199	-100	-129	-100	-560	-50	-70	-50	-79	-15	-35
250	280	-480	-1000	-300	-820	-190	-222	-110	-142	-110	-630	-56	-79	-56	-88	-17	-40
280	315	-540	-1060	-330	-850	-190	-222	-110	-142	-110	-630	-56	-79	-56	-88	-17	-40
315	355	-600	-1170	-360	-930	-210	-246	-125	-161	-125	-695	-62	-87	-62	-98	-18	-43
355	400	-680	-1250	-400	-970	-210	-246	-125	-161	-125	-695	-62	-87	-62	-98	-18	-43
400	450	-760	-1390	-440	-1070	-230	-270	-135	-175	-135	-765	-68	-95	-68	-108	-20	-47
450	500	-840	-1470	-480	-1110	-230	-270	-135	-175	-135	-765	-68	-95	-68	-108	-20	-47

Classification of diameter mm		h12		js5		j5		js6		j6		j7		k5		k6	
Above	Below	H	L	H	L	H	L	H	L	H	L	H	L	H	L	H	L
—	3	0	-100	+2	-2	+2	-2	+3	-3	+4	-2	+6	-4	+4	0	+6	0
3	6	0	-120	+2.5	-2.5	+3	-2	+4	-4	+6	-2	+8	-4	+6	+1	+9	+1
6	10	0	-150	+3	-3	+4	-2	+4.5	-4.5	+7	-2	+10	-5	+7	+1	+10	+1
10	18	0	-180	+4	-4	+5	-3	+5.5	-5.5	+8	-3	+12	-6	+9	+1	+12	+1
18	30	0	-210	+4.5	-4.5	+5	-4	+6.5	-6.5	+9	-4	+13	-8	+11	+2	+15	+2
30	40	0	-250	+5.5	-5.5	+6	-5	+8	-8	+11	-5	+15	-10	+13	+2	+18	+2
40	50	0	-250	+5.5	-5.5	+6	-5	+8	-8	+11	-5	+15	-10	+13	+2	+18	+2
50	65	0	-300	+6.5	-6.5	+6	-7	+9.5	-9.5	+12	-7	+18	-12	+15	+2	+21	+2
65	80	0	-300	+6.5	-6.5	+6	-7	+9.5	-9.5	+12	-7	+18	-12	+15	+2	+21	+2
80	100	0	-350	+7.5	-7.5	+6	-9	+11	-11	+13	-9	+20	-15	+18	+3	+25	+3
100	120	0	-350	+7.5	-7.5	+6	-9	+11	-11	+13	-9	+20	-15	+18	+3	+25	+3
120	140	0	-400	+9	-9	+7	-11	+12.5	-12.5	+14	-11	+22	-18	+21	+3	+28	+3
140	160	0	-400	+9	-9	+7	-11	+12.5	-12.5	+14	-11	+22	-18	+21	+3	+28	+3
160	180	0	-400	+9	-9	+7	-11	+12.5	-12.5	+14	-11	+22	-18	+21	+3	+28	+3
180	200	0	-460	+10	-10	+7	-13	+14.5	-14.5	+16	-13	+25	-21	+24	+4	+33	+4
200	225	0	-460	+10	-10	+7	-13	+14.5	-14.5	+16	-13	+25	-21	+24	+4	+33	+4
225	250	0	-460	+10	-10	+7	-13	+14.5	-14.5	+16	-13	+25	-21	+24	+4	+33	+4
250	280	0	-520	+11.5	-11.5	+7	-16	+16	-16	+16	-16	+26	-26	+27	+4	+36	+4
280	315	0	-520	+11.5	-11.5	+7	-16	+16	-16	+16	-16	+26	-26	+27	+4	+36	+4
315	355	0	-570	+12.5	-12.5	+7	-18	+18	-18	+18	-18	+29	-28	+29	+4	+40	+4
355	400	0	-570	+12.5	-12.5	+7	-18	+18	-18	+18	-18	+29	-28	+29	+4	+40	+4
400	450	0	-630	+13.5	-13.5	+7	-20	+20	-20	+20	-20	+31	-32	+32	+5	+45	+5
450	500	0	-630	+13.5	-13.5	+7	-20	+20	-20	+20	-20	+31	-32	+32	+5	+45	+5

unit: μm

Classification of diameter mm		g6		h5		h6		h7		h8		h9		h10		h11	
Above	Below	H	L	H	L	H	L	H	L	H	L	H	L	H	L	H	L
—	3	-2	-8	0	-4	0	-6	0	-10	0	-14	0	-25	0	-40	0	-60
3	6	-4	-12	0	-5	0	-8	0	-12	0	-18	0	-30	0	-48	0	-75
6	10	-5	-14	0	-6	0	-9	0	-15	0	-22	0	-36	0	-58	0	-90
10	18	-6	-17	0	-8	0	-11	0	-18	0	-27	0	-43	0	-70	0	-110
18	30	-7	-20	0	-9	0	-13	0	-21	0	-33	0	-52	0	-84	0	-130
30	40	-9	-25	0	-11	0	-16	0	-25	0	-39	0	-62	0	-100	0	-160
40	50	-9	-25	0	-11	0	-16	0	-25	0	-39	0	-62	0	-100	0	-160
50	65	-10	-29	0	-13	0	-19	0	-30	0	-46	0	-74	0	-120	0	-190
65	80	-10	-29	0	-13	0	-19	0	-30	0	-46	0	-74	0	-120	0	-190
80	100	-12	-34	0	-15	0	-22	0	-35	0	-54	0	-87	0	-140	0	-220
100	120	-12	-34	0	-15	0	-22	0	-35	0	-54	0	-87	0	-140	0	-220
120	140	-14	-39	0	-18	0	-25	0	-40	0	-63	0	-100	0	-160	0	-250
140	160	-14	-39	0	-18	0	-25	0	-40	0	-63	0	-100	0	-160	0	-250
160	180	-14	-39	0	-18	0	-25	0	-40	0	-63	0	-100	0	-160	0	-250
180	200	-15	-44	0	-20	0	-29	0	-46	0	-72	0	-115	0	-185	0	-290
200	225	-15	-44	0	-20	0	-29	0	-46	0	-72	0	-115	0	-185	0	-290
225	250	-15	-44	0	-20	0	-29	0	-46	0	-72	0	-115	0	-185	0	-290
250	280	-17	-49	0	-23	0	-32	0	-52	0	-81	0	-130	0	-210	0	-320
280	315	-17	-49	0	-23	0	-32	0	-52	0	-81	0	-130	0	-210	0	-320
315	355	-18	-54	0	-25	0	-36	0	-57	0	-89	0	-140	0	-230	0	-360
355	400	-18	-54	0	-25	0	-36	0	-57	0	-89	0	-140	0	-230	0	-360
400	450	-20	-60	0	-27	0	-40	0	-63	0	-97	0	-155	0	-250	0	-400
450	500	-20	-60	0	-27	0	-40	0	-63	0	-97	0	-155	0	-250	0	-400

unit: μm

Classification of diameter mm		m5		m6		n5		n6		p6	
Above	Below	H	L	H	L	H	L	H	L	H	L
—	3	+6	+2	+8	+2	+8	+4	+10	+4	+12	+6
3	6	+9	+4	+12	+4	+13	+8	+16	+8	+20	+12
6	10	+12	+6	+15	+6	+16	+10	+19	+10	+24	+15
10	18	+15	+7	+18	+7	+20	+12	+23	+12	+29	+18
18	30	+17	+8	+21	+8	+24	+15	+28	+15	+35	+22
30	40	+20	+9	+25	+9	+28	+17	+33	+17	+42	+26
40	50	+20	+9	+25	+9	+28	+17	+33	+17	+42	+26
50	65	+24	+11	+30	+11	+33	+20	+39	+20	+51	+32
65	80	+24	+11	+30	+11	+33	+20	+39	+20	+51	+32
80	100	+28	+13	+35	+13	+38	+23	+45	+23	+59	+37
100	120	+28	+13	+35	+13	+38	+23	+45	+23	+59	+37
120	140	+33	+15	+40	+15	+45	+27	+52	+27	+68	+43
140	160	+33	+15	+40	+15	+45	+27	+52	+27	+68	+43
160	180	+33	+15	+40	+15	+45	+27	+52	+27	+68	+43
180	200	+37	+17	+46	+17	+51	+31	+60	+31	+79	+50
200	225	+37	+17	+46	+17	+51	+31	+60	+31	+79	+50
225	250	+37	+17	+46	+17	+51	+31	+60	+31	+79	+50
250	280	+43	+20	+52	+20	+57	+34	+66	+34	+88	+56
280	315	+43	+20	+52	+20	+57	+34	+66	+34	+88	+56
315	355	+46	+21	+57	+21	+62	+37	+73	+37	+98	+62
355	400	+46	+21	+57	+21	+62	+37	+73	+37	+98	+62
400	450	+50	+23	+63	+23	+67	+40	+80	+40	+108	+68
450	500	+50	+23	+63	+23	+67	+40	+80	+		

● Tolerances of Housing Hole Dimensions

Classification of diameter mm		B12		E7		E11		E12		F6		F7		G6		G7	
Above	Below	H	L	H	L	H	L	H	L	H	L	H	L	H	L	H	L
—	3	+ 240	+140	+ 24	+ 14	+ 74	+ 14	+114	+ 14	+ 12	+ 6	+ 16	+ 6	+ 8	+ 2	+12	+ 2
3	6	+ 260	+140	+ 32	+ 20	+ 95	+ 20	+140	+ 20	+ 18	+10	+ 22	+10	+12	+ 4	+16	+ 4
6	10	+ 300	+150	+ 40	+ 25	+115	+ 25	+175	+ 25	+ 22	+13	+ 28	+13	+14	+ 5	+20	+ 5
10	18	+ 330	+150	+ 50	+ 32	+142	+ 32	+212	+ 32	+ 27	+16	+ 34	+16	+17	+ 6	+24	+ 6
18	30	+ 370	+160	+ 61	+ 40	+170	+ 40	+250	+ 40	+ 33	+20	+ 41	+20	+20	+ 7	+28	+ 7
30	40	+ 420	+170	+ 75	+ 50	+210	+ 50	+300	+ 50	+ 41	+25	+ 50	+25	+25	+ 9	+34	+ 9
40	50	+ 430	+180														
50	65	+ 490	+190	+ 90	+ 60	+250	+ 60	+360	+ 60	+ 49	+30	+ 60	+30	+29	+10	+40	+10
65	80	+ 500	+200														
80	100	+ 570	+220	+107	+ 72	+292	+ 72	+422	+ 72	+ 58	+36	+ 71	+36	+34	+12	+47	+12
100	120	+ 590	+240														
120	140	+ 660	+260														
140	160	+ 680	+280	+125	+ 85	+335	+ 85	+485	+ 85	+ 68	+43	+ 83	+43	+39	+14	+54	+14
160	180	+ 710	+310														
180	200	+ 800	+340														
200	225	+ 840	+380	+146	+100	+390	+100	+560	+100	+ 79	+50	+ 96	+50	+44	+15	+61	+15
225	250	+ 880	+420														
250	280	+1000	+480	+162	+110	+430	+110	+630	+110	+ 88	+56	+108	+56	+49	+17	+69	+17
280	315	+1060	+540														
315	355	+1170	+600	+182	+125	+485	+125	+695	+125	+ 98	+62	+119	+62	+54	+18	+75	+18
355	400	+1250	+680														
400	450	+1390	+760	+198	+135	+535	+135	+765	+135	+108	+68	+131	+68	+60	+20	+83	+20
450	500	+1470	+840														

Classification of diameter mm		JS7		J7		K5		K6		K7		M6		M7		N6	
Above	Below	H	L	H	L	H	L	H	L	H	L	H	L	H	L	H	L
—	3	+ 5	- 5	+ 4	- 6	0	- 4	0	- 6	0	-10	- 2	- 8	-2	-12	- 4	-10
3	6	+ 6	- 6	+ 6	- 6	0	- 5	+2	- 6	+ 3	- 9	- 1	- 9	0	-12	- 5	-13
6	10	+ 7	- 7	+ 8	- 7	+1	- 5	+2	- 7	+ 5	-10	- 3	-12	0	-15	- 7	-16
10	18	+ 9	- 9	+10	- 8	+2	- 6	+2	- 9	+ 6	-12	- 4	-15	0	-18	- 9	-20
18	30	+10	-10	+12	- 9	+1	- 8	+2	-11	+ 6	-15	- 4	-17	0	-21	-11	-24
30	40	+12	-12	+14	-11	+2	- 9	+3	-13	+ 7	-18	- 4	-20	0	-25	-12	-28
40	50																
50	65	+15	-15	+18	-12	+3	-10	+4	-15	+ 9	-21	- 5	-24	0	-30	-14	-33
65	80																
80	100	+17	-17	+22	-13	+2	-13	+4	-18	+10	-25	- 6	-28	0	-35	-16	-38
100	120																
120	140																
140	160	+20	-20	+26	-14	+3	-15	+4	-21	+12	-28	- 8	-33	0	-40	-20	-45
160	180																
180	200																
200	225	+23	-23	+30	-16	+2	-18	+5	-24	+13	-33	- 8	-37	0	-46	-22	-51
225	250																
250	280	+26	-26	+36	-16	+3	-20	+5	-27	+16	-36	- 9	-41	0	-52	-25	-57
280	315																
315	355	+28	-28	+39	-18	+3	-22	+7	-29	+17	-40	-10	-46	0	-57	-26	-62
355	400																
400	450	+31	-31	+43	-20	+2	-25	+8	-32	+18	-45	-10	-50	0	-63	-27	-67
450	500																

unit: μm

Classification of diameter mm		H6		H7		H8		H9		H10		H11		JS6		J6	
Above	Below	H	L	H	L	H	L	H	L	H	L	H	L	H	L	H	L
—	3	+ 6	0	+10	0	+14	0	+ 25	0	+ 40	0	+ 60	0	+ 3	- 3	+ 2	-4
3	6	+ 8	0	+12	0	+18	0	+ 30	0	+ 48	0	+ 75	0	+ 4	- 4	+ 5	-3
6	10	+ 9	0	+15	0	+22	0	+ 36	0	+ 58	0	+ 90	0	+ 4.5	- 4.5	+ 5	-4
10	18	+11	0	+18	0	+27	0	+ 43	0	+ 70	0	+110	0	+ 5.5	- 5.5	+ 6	-5
18	30	+13	0	+21	0	+33	0	+ 52	0	+ 84	0	+130	0	+ 6.5	- 6.5	+ 8	-5
30	40																
40	50	+16	0	+25	0	+39	0	+ 62	0	+100	0	+160	0	+ 8	- 8	+10	-6
50	65																
65	80	+19	0	+30	0	+46	0	+ 74	0	+120	0	+190	0	+ 9.5	- 9.5	+13	-6
80	100																
100	120	+22	0	+35	0	+54	0	+ 87	0	+140	0	+220	0	+11	-11	+16	-6
120	140																
140	160	+25	0	+40	0	+63	0	+100	0	+160	0	+250	0	+12.5	-12.5	+18	-7
160	180																
180	200	+29	0	+46	0	+72	0	+115	0	+185	0	+290	0	+14.5	-14.5	+22	-7
200	225																
225	250	+32	0	+52	0	+81	0	+130	0	+210	0	+320	0	+16	-16	+25	-7
250	280																
280	315	+36	0	+57	0	+89	0	+140	0	+230	0	+360	0	+18	-18	+29	-7
315	355																
355	400	+40	0	+63	0	+97	0	+155	0	+250	0	+400	0	+20	-20	+33	-7
400	450																
450	500																

unit: μm

Classification of diameter mm		N7		P6		P7		R7		S7	
Above	Below	H	L	H	L	H	L	H	L	H	L
—	3	- 4	-14	- 6	-12	- 6	- 16	- 10	- 20	- 14	- 24
3	6	- 4	-16	- 9	-17	- 8	- 20	- 11	- 23	- 15	- 27
6	10	- 4	-19	-12	-21	- 9	- 24	- 13	- 28	- 17	- 32
10	18	- 5	-23	-15	-26	-11	- 29	- 16	- 34	- 21	- 39
18	30	- 7	-28	-18	-31	-14	- 35	- 20	- 41	- 27	- 48
30	40	- 8	-33	-21	-37	-17	- 42	- 25	- 50	- 34	- 59
40	50										
50	65	- 9	-39	-26	-45	-21	- 51	- 30	- 60	- 42	- 72
65	80										
80	100	-10	-45	-30	-52	-24	- 59	- 38	- 73	- 58	- 93
100	120										
120	140	-12	-52	-36	-61	-28	- 68	- 48	- 88	- 77	-117
140	160										
160	180										
180	200	-14	-60	-41	-70	-33	- 79	- 60	-106	-105	-151
200	225										
225	250										
250	280	-14	-66	-47	-79	-36	- 88	- 74	-126	-138	-190
280	315										
315	355	-16	-73	-51	-87	-41	- 98	- 87	-144	-169	-226
355	400										
400	450	-17	-80	-55	-95	-45	-108	-103	-166	-209	-272
450	500										

Model Code Index

Model code	Series name	Catalog name	Page	Model code	Series name	Catalog name	Page
B				LM...F AJ	Linear Bushing	RED	II-161
B				LM...F OP	Linear Bushing	RED	II-161
BG	Stroke Rotary Cage	RED	II-192	LM...F UU	Linear Bushing	RED	II-163
BK...A	Miniature Stroke Rotary Bushing	RED	II-187	LM...F UU AJ	Linear Bushing	RED	II-163
BSP...SL	Precision Linear Slide Unit	RED	II- 89	LM...F UU OP	Linear Bushing	RED	II-163
BSPG...SL	Precision Linear Slide Unit	RED	II- 91	LM...N	Linear Bushing	RED	II-147
BSR...SL	Precision Linear Slide Unit	RED	II- 93	LM...N AJ	Linear Bushing	RED	II-147
BSU...A	Linear Slide Unit	RED	II- 99	LM...N F	Linear Bushing	RED	II-161
BWU	High Rigidity Precision Linear Slide Unit	RED	II- 81	LM...N F AJ	Linear Bushing	RED	II-161
C				LM...N F OP	Linear Bushing	RED	II-161
C				LM...N F UU	Linear Bushing	RED	II-163
CRW	Crossed Roller Way	RED	II- 33	LM...N F UU AJ	Linear Bushing	RED	II-163
CRW...SL	Crossed Roller Way	RED	II- 33	LM...N F UU OP	Linear Bushing	RED	II-163
CRWG	Anti-Creep Cage Crossed Roller Way	RED	II- 27	LM...N OP	Linear Bushing	RED	II-147
CRWG...H	Anti-Creep Cage Crossed Roller Way H	RED	II- 31	LM...N UU	Linear Bushing	RED	II-151
CRWM	Crossed Roller Way	RED	II- 49	LM...N UU AJ	Linear Bushing	RED	II-151
CRWU	Crossed Roller Way Unit	RED	II- 63	LM...N UU OP	Linear Bushing	RED	II-151
CRWU...R	Crossed Roller Way Unit	RED	II- 67	LM...OP	Linear Bushing	RED	II-147
CRWU...RS	Crossed Roller Way Unit	RED	II- 71	LM...UU	Linear Bushing	RED	II-151
CRWUG	Anti-Creep Cage Crossed Roller Way Unit	RED	II- 61	LM...UU AJ	Linear Bushing	RED	II-151
F				LM...UU OP	Linear Bushing	RED	II-151
F				LMB	Linear Bushing	RED	II-159
FT	Flat Roller Cage	RED	II-211	LMB...AJ	Linear Bushing	RED	II-159
FT...N	Flat Roller Cage	RED	II-211	LMB...N	Linear Bushing	RED	II-159
FT...V	Flat Roller Cage	RED	II-211	LMB...N AJ	Linear Bushing	RED	II-159
FTW...A	Flat Roller Cage	RED	II-212	LMB...N OP	Linear Bushing	RED	II-159
FTW...VA	Flat Roller Cage	RED	II-212	LMB...OP	Linear Bushing	RED	II-159
G				LME	Linear Bushing	RED	II-155
G				LME...AJ	Linear Bushing	RED	II-155
GSN	Roller Way	RED	II-204	LME...F	Linear Bushing	RED	II-165
L				LME...F AJ	Linear Bushing	RED	II-165
L				LME...F OP	Linear Bushing	RED	II-165
LM	Linear Bushing	RED	II-147	LME...F UU	Linear Bushing	RED	II-167
LM...AJ	Linear Bushing	RED	II-147	LME...F UU AJ	Linear Bushing	RED	II-167
LM...F	Linear Bushing	RED	II-161	LME...F UU OP	Linear Bushing	RED	II-167
				LME...N	Linear Bushing	RED	II-155
				LME...N AJ	Linear Bushing	RED	II-155
				LME...N F	Linear Bushing	RED	II-165
				LME...N F AJ	Linear Bushing	RED	II-165

Note: BLUE denotes CAT-1600E, while RED denotes CAT-1601E.

Model Code Index

Model code	Series name	Catalog name	Page	Model code	Series name	Catalog name	Page
LME...N F OP	Linear Bushing	RED	II-165	LRXS	Linear Roller Way Super X	BLUE	II-209
LME...N F UU	Linear Bushing	RED	II-167	LRXSC	Linear Roller Way Super X	BLUE	II-209
LME...N F UU AJ	Linear Bushing	RED	II-167	LRXSG	Linear Roller Way Super X	BLUE	II-209
LME...N F UU OP	Linear Bushing	RED	II-167	LSAG	Linear Ball Spline G	RED	II-123
LME...N OP	Linear Bushing	RED	II-155	LSAGF	Linear Ball Spline G	RED	II-127
LME...N UU	Linear Bushing	RED	II-157	LSAGFL	Linear Ball Spline G	RED	II-127
LME...N UU AJ	Linear Bushing	RED	II-157	LSAGFLT	Linear Ball Spline G	RED	II-127
LME...N UU OP	Linear Bushing	RED	II-157	LSAGFT	Linear Ball Spline G	RED	II-127
LME...OP	Linear Bushing	RED	II-155	LSAGL	Linear Ball Spline G	RED	II-123
LME...UU	Linear Bushing	RED	II-157	LSAGLT	Linear Ball Spline G	RED	II-123
LME...UU AJ	Linear Bushing	RED	II-157	LSAGT	Linear Ball Spline G	RED	II-123
LME...UU OP	Linear Bushing	RED	II-157	LWE	Linear Way E	BLUE	II- 75
LMG	Linear Bushing G	RED	II-139	LWE...Q	Low Decibel Linear Way E	BLUE	II- 75
LMGT	Linear Bushing G	RED	II-139	LWE...SL	Linear Way E	BLUE	II- 75
LMS	Miniature Linear Bushing	RED	II-172	LWEC	Linear Way E	BLUE	II- 75
LMS...F	Miniature Linear Bushing	RED	II-172	LWEC...SL	Linear Way E	BLUE	II- 75
LMS...F UU	Miniature Linear Bushing	RED	II-172	LWEG	Linear Way E	BLUE	II- 75
LMS...UU	Miniature Linear Bushing	RED	II-172	LWEG...SL	Linear Way E	BLUE	II- 75
LMSL	Miniature Linear Bushing	RED	II-172	LWES	Linear Way E	BLUE	II- 83
LMSL...F	Miniature Linear Bushing	RED	II-172	LWES...Q	Low Decibel Linear Way E	BLUE	II- 83
LMSL...F UU	Miniature Linear Bushing	RED	II-172	LWES...SL	Linear Way E	BLUE	II- 83
LMSL...UU	Miniature Linear Bushing	RED	II-172	LWESC	Linear Way E	BLUE	II- 83
LRWM	Linear Way Module	BLUE	II-243	LWESC...SL	Linear Way E	BLUE	II- 83
LRWX...B	Linear Roller Way X	BLUE	II-227	LWESG	Linear Way E	BLUE	II- 83
LRWXH	Linear Roller Way X	BLUE	II-229	LWESG...SL	Linear Way E	BLUE	II- 83
LRX	Linear Roller Way Super X	BLUE	II-191	LWET	Linear Way E	BLUE	II- 79
LRXC	Linear Roller Way Super X	BLUE	II-191	LWET...Q	Low Decibel Linear Way E	BLUE	II- 79
LRXD	Linear Roller Way Super X	BLUE	II-199	LWET...SL	Linear Way E	BLUE	II- 79
LRXD...SL	Linear Roller Way Super X	BLUE	II-199	LWETC	Linear Way E	BLUE	II- 79
LRXDC	Linear Roller Way Super X	BLUE	II-199	LWETC...SL	Linear Way E	BLUE	II- 79
LRXDC...SL	Linear Roller Way Super X	BLUE	II-199	LWETG	Linear Way E	BLUE	II- 79
LRXDG	Linear Roller Way Super X	BLUE	II-199	LWETG...SL	Linear Way E	BLUE	II- 79
LRXDG...SL	Linear Roller Way Super X	BLUE	II-199	LWFF	Linear Way F	BLUE	II-151
LRXDL	Linear Roller Way Super X	BLUE	II-207	LWFH	Linear Way F	BLUE	II-149
LRXG	Linear Roller Way Super X	BLUE	II-191	LWFS	Linear Way F	BLUE	II-153
LRXH	Linear Roller Way Super X	BLUE	II-191	LWFS...SL	Linear Way F	BLUE	II-153
LRXHC	Linear Roller Way Super X	BLUE	II-191	LWH...B	Linear Way H	BLUE	II-107
LRXHG	Linear Roller Way Super X	BLUE	II-191	LWH...M	Linear Way H	BLUE	II-107
LRXL	Linear Roller Way Super X	BLUE	II-197	LWH...MU	Linear Way H	BLUE	II-107

Note: BLUE denotes CAT-1600E, while RED denotes CAT-1601E.

Model Code Index

Model code	Series name	Catalog name	Page	Model code	Series name	Catalog name	Page
L							
LWH...SL	Linear Way H	BLUE	II-107	LWLF...B	Linear Way L	BLUE	II-33
LWHD	Linear Way H	BLUE	II-121	LWLF...N	Linear Way L	BLUE	II-33
LWHD...B	Linear Way H	BLUE	II-123	LWLG...B	Linear Way L	BLUE	II-25
LWHD...M	Linear Way H	BLUE	II-123	LWLG...N	Linear Way L	BLUE	II-25
LWHD...MU	Linear Way H	BLUE	II-123	LWLM	Linear Way Module	BLUE	II-241
LWHD...SL	Linear Way H	BLUE	II-121	LWU...B	Linear Way U	BLUE	II-167
LWHDG	Linear Way H	BLUE	II-123	M			
LWHDG...SL	Linear Way H	BLUE	II-121	MAG	C-Lube Linear Ball Spline MAG	RED	II-123
LWHG	Linear Way H	BLUE	II-107	MAGF	C-Lube Linear Ball Spline MAG	RED	II-127
LWHS...B	Linear Way H	BLUE	II-127	MAGFT	C-Lube Linear Ball Spline MAG	RED	II-127
LWHS...M	Linear Way H	BLUE	II-127	MAGL	C-Lube Linear Ball Spline MAG	RED	II-123
LWHS...MU	Linear Way H	BLUE	II-127	MAGLT	C-Lube Linear Ball Spline MAG	RED	II-123
LWHS...SL	Linear Way H	BLUE	II-127	MAGT	C-Lube Linear Ball Spline MAG	RED	II-123
LWHS	Linear Way H	BLUE	II-127	ME	C-Lube Linear Way ME	BLUE	II-75
LWHT	Linear Way H	BLUE	II-113	ME...SL	C-Lube Linear Way ME	BLUE	II-75
LWHT...B	Linear Way H	BLUE	II-113	MEC	C-Lube Linear Way ME	BLUE	II-75
LWHT...M	Linear Way H	BLUE	II-113	MEC...SL	C-Lube Linear Way ME	BLUE	II-75
LWHT...MU	Linear Way H	BLUE	II-113	MEG	C-Lube Linear Way ME	BLUE	II-75
LWHT...SL	Linear Way H	BLUE	II-113	MEG...SL	C-Lube Linear Way ME	BLUE	II-75
LWHTG	Linear Way H	BLUE	II-115	MES	C-Lube Linear Way ME	BLUE	II-83
LWHY	Linear Way H	BLUE	II-131	MES...SL	C-Lube Linear Way ME	BLUE	II-83
LWL	Linear Way L	BLUE	II-23	MESC	C-Lube Linear Way ME	BLUE	II-83
LWL...B	Linear Way L	BLUE	II-25	MESC...SL	C-Lube Linear Way ME	BLUE	II-83
LWL...B CS	Linear Way L	BLUE	II-27	MESG	C-Lube Linear Way ME	BLUE	II-83
LWL...N	Linear Way L	BLUE	II-25	MESG...SL	C-Lube Linear Way ME	BLUE	II-83
LWL...Y	Linear Way L	BLUE	II-23	MET	C-Lube Linear Way ME	BLUE	II-79
LWLC	Linear Way L	BLUE	II-23	MET...SL	C-Lube Linear Way ME	BLUE	II-79
LWLC...B	Linear Way L	BLUE	II-25	METC	C-Lube Linear Way ME	BLUE	II-79
LWLC...N	Linear Way L	BLUE	II-25	METC...SL	C-Lube Linear Way ME	BLUE	II-79
LWLF	Linear Way L	BLUE	II-31	METG	C-Lube Linear Way ME	BLUE	II-79
LWLF...B	Linear Way L	BLUE	II-31	METG...SL	C-Lube Linear Way ME	BLUE	II-79
LWLF...BCS	Linear Way L	BLUE	II-35	MH	C-Lube Linear Way MH	BLUE	II-107
LWLF...N	Linear Way L	BLUE	II-31	MH...M	C-Lube Linear Way MH	BLUE	II-107
LWLFC	Linear Way L	BLUE	II-31	MH...MU	C-Lube Linear Way MH	BLUE	II-107
LWLFC...B	Linear Way L	BLUE	II-31	MHD	C-Lube Linear Way MH	BLUE	II-121
LWLFC...N	Linear Way L	BLUE	II-31	MHD...M	C-Lube Linear Way MH	BLUE	II-123
				MHD...MU	C-Lube Linear Way MH	BLUE	II-123

Note: BLUE denotes CAT-1600E, while RED denotes CAT-1601E.

Model Code Index

Model code	Series name	Catalog name	Page	Model code	Series name	Catalog name	Page
MHD...SL	C-Lube Linear Way MH	BLUE	II-121	MXNG	C-Lube Linear Roller Way Super MX	BLUE	II-213
MHDC...SL	C-Lube Linear Way MH	BLUE	II-121	MXNL	C-Lube Linear Roller Way Super MX	BLUE	II-213
MHDG	C-Lube Linear Way MH	BLUE	II-123	MXNS	C-Lube Linear Roller Way Super MX	BLUE	II-215
MHDG...SL	C-Lube Linear Way MH	BLUE	II-121	MXNSG	C-Lube Linear Roller Way Super MX	BLUE	II-215
MHG	C-Lube Linear Way MH	BLUE	II-107	MXNSL	C-Lube Linear Roller Way Super MX	BLUE	II-215
MHS	C-Lube Linear Way MH	BLUE	II-127	MXS	C-Lube Linear Roller Way Super MX	BLUE	II-209
MHS...M	C-Lube Linear Way MH	BLUE	II-129	MXSC	C-Lube Linear Roller Way Super MX	BLUE	II-209
MHS...MU	C-Lube Linear Way MH	BLUE	II-129	MXSG	C-Lube Linear Roller Way Super MX	BLUE	II-209
MHS...SL	C-Lube Linear Way MH	BLUE	II-127	MXSL	C-Lube Linear Roller Way Super MX	BLUE	II-209
MHSG	C-Lube Linear Way MH	BLUE	II-127	O			
MHT	C-Lube Linear Way MH	BLUE	II-113	OR...A	Miniature Stroke Rotary Bushing	RED	II-187
MHT...M	C-Lube Linear Way MH	BLUE	II-115	R			
MHT...MU	C-Lube Linear Way MH	BLUE	II-115	RW	Roller Way	RED	II-201
MHT...SL	C-Lube Linear Way MH	BLUE	II-113	RWB	Roller Way	RED	II-202
MHTG	C-Lube Linear Way MH	BLUE	II-113	S			
ML	C-Lube Linear Way ML	BLUE	II-23	SF...A	Miniature Stroke Rotary Bushing	RED	II-187
MLC	C-Lube Linear Way ML	BLUE	II-23	SR	Roller Way	RED	II-203
MLF	C-Lube Linear Way ML	BLUE	II-31	ST	Stroke Rotary Bushing	RED	II-179
MLFC	C-Lube Linear Way ML	BLUE	II-31	ST...B	Stroke Rotary Bushing	RED	II-179
MLFG	C-Lube Linear Way ML	BLUE	II-33	ST...UU	Stroke Rotary Bushing	RED	II-181
MLG	C-Lube Linear Way ML	BLUE	II-25	ST...UU B	Stroke Rotary Bushing	RED	II-181
MLL	C-Lube Linear Way ML	BLUE	II-27	STS	Miniature Stroke Rotary Bushing	RED	II-187
MLV	C-Lube Linear Way MLV	BLUE	II-47	STSI	Miniature Stroke Rotary Bushing	RED	II-187
MUL	C-Lube Linear Way MUL	BLUE	II-167				
MV	C-Lube Linear Way MV	BLUE	II-59				
MX	C-Lube Linear Roller Way Super MX	BLUE	II-191				
MXC	C-Lube Linear Roller Way Super MX	BLUE	II-191				
MXD	C-Lube Linear Roller Way Super MX	BLUE	II-199				
MXD...SL	C-Lube Linear Roller Way Super MX	BLUE	II-199				
MXDC	C-Lube Linear Roller Way Super MX	BLUE	II-199				
MXDG	C-Lube Linear Roller Way Super MX	BLUE	II-199				
MXDL	C-Lube Linear Roller Way Super MX	BLUE	II-201				
MXG	C-Lube Linear Roller Way Super MX	BLUE	II-191				
MXH	C-Lube Linear Roller Way Super MX	BLUE	II-191				
MXHC	C-Lube Linear Roller Way Super MX	BLUE	II-191				
MXHG	C-Lube Linear Roller Way Super MX	BLUE	II-191				
MXHL	C-Lube Linear Roller Way Super MX	BLUE	II-191				
MXL	C-Lube Linear Roller Way Super MX	BLUE	II-191				
MXN	C-Lube Linear Roller Way Super MX	BLUE	II-213				

Note: BLUE denotes CAT-1600E, while RED denotes CAT-1601E.

IKO Linear Motion Rolling Guide Series,

Configuration of General Catalog

IKO Linear Motion Rolling Guide Series General Catalog Consists of **BLUE** (CAT-1600E) and

RED (CAT-1601E), the two volumes.



CAT-1600E

【Models】

- Rail Guide Type
- Endless Linear Motion Type

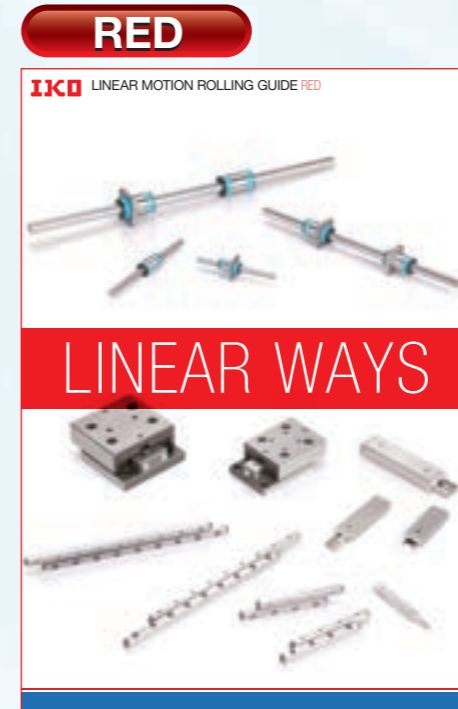

CAT-1601E

【Models】

- Rail Guide Type
- Limited Linear Motion Type
- Shaft Guide Type
- Endless Linear Motion Type
- Limited Linear Motion Type + Rolling Motion Type
- Flat Guide Type
- Endless Linear Motion Type
- Limited Linear Motion Type

C-Lube Linear Way ML Linear Way L C-Lube Linear Way MLV C-Lube Linear Way MV Linear Way E C-Lube Linear Way ME Linear Way H C-Lube Linear Way MH Linear Way H

ML · LWL



MLV

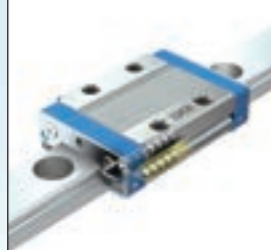

MV



ME · LWE



MH · LWH



Linear Way F

LWF



C-Lube Linear Way MUL Linear Way U

MUL · LWU



C-Lube Linear Roller Way Super MX Linear Roller Way Super X

MX · LRX



Linear Roller Way X

LRWX



Linear Way Module

LWLM · LRWM



Rail Guide Type
Crossed Roller Way

CRW(G)(···H)
CRWU(G)



Rail Guide Type
Linear Slide Unit

BWU·BSP(G)
BSU···A



Shaft Guide Type
Linear Ball Spline

MAG·LSAG



Shaft Guide Type
Linear Bushing

LMG · LM · LMS



Shaft Guide Type
Stroke Rotary Bushing

ST · STSI · BG



Flat Guide Type
Roller Way & Flat Roller Cage

RW · SR · GSN
FT·FTW···A



IKO Introduction of Technical Service Site

"IKO Technical Service Site" can be accessed from our home page. The site provides various tools for selecting Linear Ways and Linear Roller Ways. Please utilize these tools for assistance when selecting products. Additionally the site also provides CAD data and product catalogs for the Needle Series, Linear Motion Rolling Guide Series, and Mechatronics Series for download. Please utilize them to improve your design efficiency.

<https://www.ikont.co.jp/eg/>

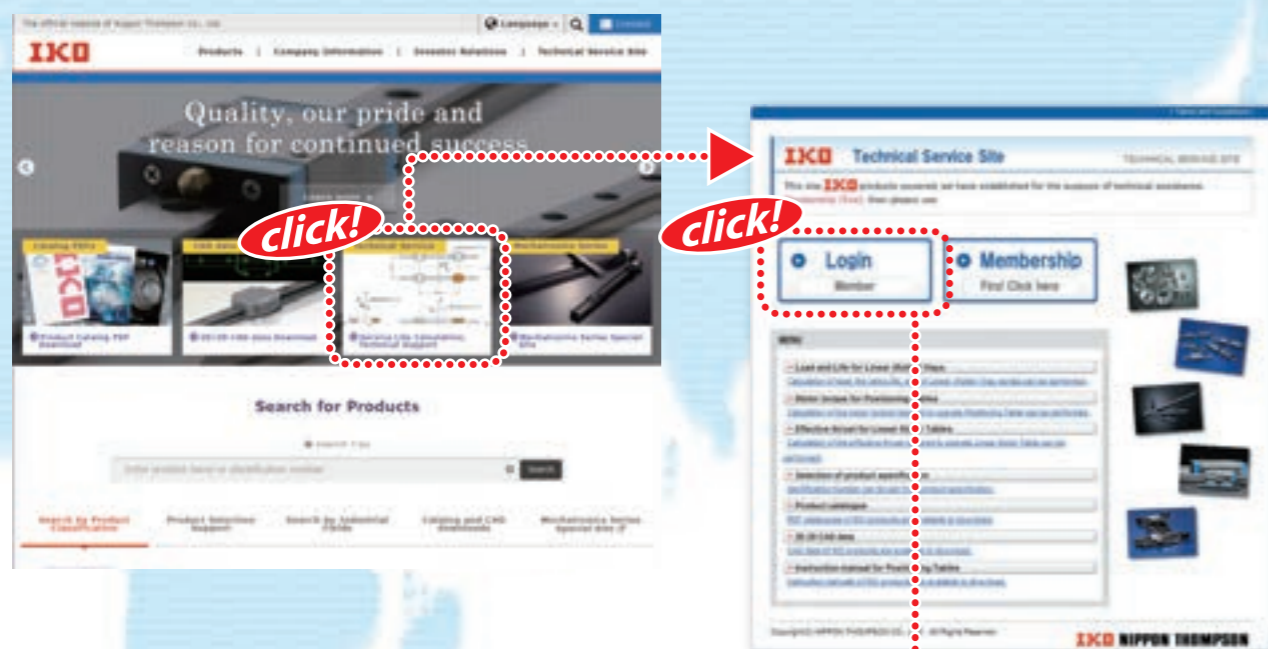

1. Technical calculations

For Linear Way/Linear Roller Way load and life calculation, you can obtain the calculated load and the rating life by entering the operating conditions. Also you can derive the motor torque required for operation and the effective thrust force during operation in the sections of motor torque calculation and calculation of effective thrust force of linear motor tables respectively, and output the calculation results in PDF format, as well as save the histories.



2. Selection of Identification Number

By selecting such specification as model code, dimensions, part code, material code, preload symbol, classification symbol, interchangeable code and supplemental code of Linear ways/Linear roller ways, you can easily specify the identification number used for ordering.

Also you can browse the CAD data of the selected products, calculate the load, and output the selection results in PDF format, as well as save the histories.



3. Downloading CAD data

2-dimensional CAD data (DXF file)

There are two types of figures, brief figure and detailed figure. The brief figure shows only the external view lines, and the detailed figure shows the detailed lines. The drawing consists of three drawings: front view, side view and plain view. The scale shows only the original size (1:1), and it does not show dimension lines.



3-dimensional CAD data

It is linked to the mechanical parts CAD library "PART community". Entering the rail dimension and option contents to the detail, you can view the 2D/3D CAD data suitable for the specification for free of charge.



4. Downloading Catalog and Operation Manual

You can download product catalogs of needle series, linear motion rolling guide series and mechatronics series, operation manuals of precision positioning tables and various electrical components in PDF format, as well as support software for precision positioning tables. If you would like a copy of our catalog, please visit the IKO official website and apply for the catalog, or contact our regional office or sales office nearby.

Oil Minimum

IKO Gentle to The Earth

Nippon Thompson Co., Ltd. is working to develop global environment-friendly products.

It is committed to developing products that make its customers' machinery and equipment more reliable, thereby contributing to preserving the global environment.

This development stance manifests well in the keyword "Oil Minimum."

Our pursuit of Oil Minimum has led to the creation of IKO's proprietary family of lubricating parts as "C-Lube."

- IKO Linear Motion Rolling Guides are manufactured through a control system that alleviates their impact on the global environment to meet the quality requirements of ISO 14001 in compliance with the quality requirements level of ISO 9001 for quality improvement.
- The standard products listed in this catalog comply with the specifications of the ten hazardous materials cited in the European RoHS Directive.

NIPPON THOMPSON CO., LTD. (JAPAN)

Head Office : 19-19, Takanawa 2-chome, Minato-ku,
Tokyo, 108-8586, Japan
Phone : +81 (0)3-3448-5850
Fax : +81 (0)3-3447-7637
E-mail : ntt@ikonet.co.jp
URL : https://www.ikonet.co.jp/eg/
Plant : Gifu, Kamakura



IKO INTERNATIONAL, INC. (U.S.A.)

East Coast Operation (Sales Head Office)

91 Walsh Drive,
Parsippany, NJ, 07054,
U.S.A.
Phone : +1-973-402-0254
Toll Free : +1-800-922-0337
Fax : +1-973-402-0441
E-mail : eco@ikonet.co.jp



Midwest Operation

101 Mark Street, Unit-G,
Wood Dale, IL, 60191,
U.S.A.
Phone : +1-630-766-6464
Toll Free : +1-800-323-6694
Fax : +1-630-766-6869
E-mail : mwo@ikonet.co.jp

West Coast Operation

9830 Norwalk Boulevard, Suite 198,
Santa Fe Springs, CA, 90670,
U.S.A.
Phone : +1-562-941-1019
Toll Free : +1-800-252-3665
Fax : +1-562-941-4027
E-mail : wco@ikonet.co.jp

Silicon Valley Sales Office

1500 Wyatt Drive, Suite 10,
Santa Clara, CA, 95054,
U.S.A.
Phone : +1-408-492-0240
Toll Free : +1-800-252-3665
Fax : +1-408-492-0245
E-mail : wco@ikonet.co.jp

Southeast Operation

3235 Satellite Boulevard Building 400, Suite 230,
Duluth, GA, 30096,
U.S.A.
Phone : +1-770-418-1904
Toll Free : +1-800-874-6445
Fax : +1-770-418-9403
E-mail : seo@ikonet.co.jp

Southwest Operation

6191 N STATE HIGHWAY 161, STE 440,
IRVING, TX 75038-2264,
U.S.A.
Phone : +1-972-925-0444
Toll Free : +1-800-295-7886
Fax : +1-972-707-0385
E-mail : swo@ikonet.co.jp

IKO THOMPSON BEARINGS CANADA, INC.(CANADA)

731-2425, Matheson Boulevard East, 7th floor,
Mississauga, Ontario, L4W 5K4, Canada
Phone : +1-647-931-3933
E-mail : itc@ikonet.co.jp

IKO BRASIL SERVIÇOS EMPRESARIAIS LTDA. (BRAZIL)

Rua Frei Caneca 1407,
Condominio Edificio Barão de Monte Cedro,
Cjs. 801/802, Consolação, São Paulo- SP
Cep: 01307-909
Phone : +55 (0)11-2366-3033
E-mail : itb@ikonet.co.jp

NIPPON THOMPSON EUROPE B.V. (EUROPE)

The Netherlands (Sales Head Office)

Keersopstraat 35,
3044 EX, Rotterdam,
The Netherlands
Phone : +31 (0)10-462 68 68
E-mail : nte@ikonet.co.jp



Germany Branch

Mündelheimer Weg 54,
40472 Düsseldorf,
Germany
Phone : +49 (0)211-41 40 61
Fax : +49 (0)211-42 76 93
E-mail : ntd@ikonet.co.jp

Regensburg Sales Office

Im Gewerbepark D 04,
93059 Regensburg,
Germany
Phone : +49 (0)941-20 60 70
Fax : +49 (0)941-20 60 719
E-mail : ntdr@iko-nt.de

U.K. Branch

2 Vincent Avenue, Crownhill,
Milton Keynes, Bucks, MK8 0AB,
United Kingdom
Phone : +44 (0)1908-566144
E-mail : sales@iko.co.uk

Spain Branch

Autovia Madrid-Barcelona, Km. 43,700
Polig. Ind. AIDA - Nove A-8, Ofic. 2-1ª
19200-Azuqueca de Henares,
(Guadalajara) Spain
Phone : +34 949-26 33 90
Fax : +34 949-26 31 13
E-mail : nts@ikonet.co.jp

France Branch

Bâtiment le Raphaël-Paris, Nord 2,
22 avenue des Nations
BP54394 Villepinte
95943 ROISSY C.D.G Cedex
France
Phone : +33 (0)1-48 16 57 39
Fax : +33 (0)1-48 16 57 46
E-mail : ntf@ikont.eu

IKO THOMPSON ASIA CO., LTD. (THAILAND)

Unit 305,3rd Fl., Zuellig house, 1-7 Silom Rd.,
Silom Bangrak, Bangkok 10500, Thailand
Phone : +66 (0)2637-5115
Fax : +66 (0)2637-5116
E-mail : ita@ikonet.co.jp

See you again at
IKO Website
<https://www.ikonet.co.jp/eg/>

IKO THOMPSON KOREA CO.,LTD. (KOREA)

201, Worldvision Bldg., 77-1, Yeouinaru-ro,
Yeongdeungpo-gu, Seoul, Korea
Phone : +82 (0)2-6337-5851
Fax : +82 (0)2-6337-5852
E-mail : itk@ikonet.co.jp

IKO-THOMPSON (SHANGHAI) LTD. (CHINA)

Shanghai (Sales Head Office)

2301-02, 2310, MetroPlaza No.555,
LouShanGuan Road, Changning District,
Shanghai, People's Republic of China, 200051
Phone : +86 (0)21-3250-5525
Fax : +86 (0)21-3250-5526
E-mail : ntc@ikonet.co.jp

Beijing Branch

Room 1909, Tower C Oriental Media Center,
Guanghua Road No. 4 Chaoyang District, Beijing,
People's Republic of China, 100026
Phone : +86 (0)10-6515-7681
Fax : +86 (0)10-6515-7689
E-mail : ntc@ikonet.co.jp

Guangzhou Branch

Room 834, Garden Tower, Garden Hotel
368 Huanshi East Road, Yuexiu District, Guangzhou,
Guangdong
People's Republic of China, 510064
Phone : +86 (0)20-8384-0797
Fax : +86 (0)20-8381-2863
E-mail : ntc@ikonet.co.jp

Wuhan Branch

Room 2300, Truroll Plaza No.72, Wusheng Road,
Qiao kou District, Wuhan, Hubei,
People's Republic of China, 430033
Phone : +86 (0)27-8556-1610
Fax : +86 (0)27-8556-1630
E-mail : ntc@ikonet.co.jp

Shenzhen Branch

Room1808, KEENSTAR Building 18,
Chuangye 2nd Rd 248, Bao'an, Shenzhen, Guangdong,
People's Republic of China, 518081
Phone : +86 (0)755-2265-0553
Fax : +86 (0)755-2298-0665
E-mail : ntc@ikonet.co.jp

Xian Branch

Room 2010, Block B, Chaoyang International Plaza,
No. 166,
Changle West Road, Xincheng District Xi'an, Shanxi,
People's Republic of China, 710032
Phone : +86 (0)29-8323-5115
E-mail : ntc@ikonet.co.jp

Qingdao Branch

Room 608, Building 47, Huarun City,
No. 101 Shenzhen Road, Laoshan District,
Qingdao City, Shandong
People's Republic of China, 266100
Phone : +86 (0)532-8670-2246
Fax : +86 (0)532-8670-2242
E-mail : ntc@ikonet.co.jp

Shenyang Branch

2-1203 Tower I, City Plaza Shenyang NO.206,
Nanjing North Street, Heping District,
Shenyang, Liaoning
People's Republic of China, 110001
Phone : +86 (0)24-2334-2662
Fax : +86 (0)24-2334-2442
E-mail : ntc@ikonet.co.jp

Ningbo Office

Room 3406, Zhongnongxin Building, No.181,
Zhongshan East Road, Haishu District,
Ningbo, Zhejiang
People's Republic of China, 315000
Phone : +86 (0)574-8718-9535
Fax : +86 (0)574-8718-9533
E-mail : ntc@ikonet.co.jp