

Types of Mechatronics Series

	Drive model	
Ball screw drive		
Linear motor drive	Moving magnet	
	Moving coil	
Timing belt drive		
Worm gear drive		

Characteristics of Mechatronics Series

	Motion direction	Stroke length	Thrust force	Speed	Acceleration	Positioning accuracy
Ball screw drive	Linear					
	Vertical	○	◎	○	△	○
	Alignment					
Linear motor drive	Moving magnet					
	Linear	△	△	◎	◎	◎
Moving coil	Alignment					
Linear motor drive	Moving coil					
	Linear	◎	△	◎	◎	◎
Timing belt drive	Linear	◎	○	◎	◎	△
Worm gear drive	Rotation	◎	◎	△	△	○

Code description ◎Excellent ○Good △Fair

Precision Positioning Table TE

- High-strength aluminum alloy is used for main components
- Light weight, low profile and compact positioning table



Ball screw drive
Linear



TE...B

II-4 >>>

Precision Positioning Table TU

- High rigidity U-shaped track rail adopted
- Various table specifications are available according to your use.

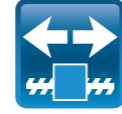

Ball screw drive
Linear



TU

II-32 >>>

Precision Positioning Table LB

- High-speed type using a timing belt drive
- Parallel arrangement of Linear Way ensures stable and high operating performance.



Timing belt drive
Linear



TSLB

II-232 >>>

Nano Linear NT

- Pursuing ultimate compactification
- Very low profile of NT38V: only 11mm
- A wide variety of selections support optimal choice according to your use.



Linear motor drive
Linear

NT...V NT...XZ
NT...H NT...XZH



II-244 >>>

Precision Positioning Table L

- Standard type highly-proven in various fields
- Parallel arrangement of Linear Ways with stable performance

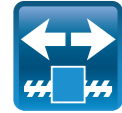

Ball screw drive
Linear



TSL...M

II-102 >>>

Precision Positioning Table LH

- Component parts from rigorous selection ensure high accuracy and reliability.
- High rigidity and large carrying mass

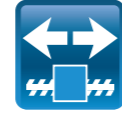

Ball screw drive
Linear



TSLH...M

CTLH...M

II-122 >>>

Alignment Stage SA

- Sectional height of 3 axes X, Y and θ is only 52mm (SA65DE).
- X- and Y-axis: 0.1 μ m, θ -axis: excellent resolution as high as 0.25 sec (SA200DE)



Linear motor drive
Alignment
Linear



SA...DE

II-276 >>>

Linear Motor Table LT

- Both high speed and high resolution are achieved.
- High acceleration / deceleration, high response and smooth operations
- Long term maintenance free specification with C-Lube built in



Linear motor drive
Linear

LT...CE LT...H
LT...LD

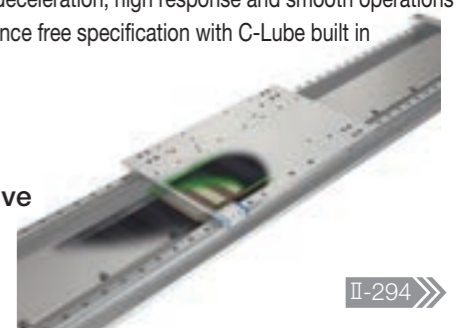

II-294 >>>

Super Precision Positioning Table TX

- Achieved ultimate positioning performance with rolling guide type
- High accuracy attained by fully-closed loop control

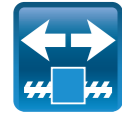

Ball screw drive
Linear



TX...M

CTX...M

II-150 >>>

Cleanroom Precision Positioning Table TC

- Optional for use in high cleanliness environment for semiconductor and LCD manufacturing machines
- Light weight, low profile and compact positioning table

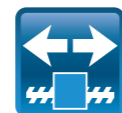

Ball screw drive
Linear



TC...EB

II-172 >>>

Alignment Table AT

- High accuracy positioning ensuring precise angle correction
- Crossed Roller Bearing ensures high rigidity and compactness.



Ball screw drive
Alignment

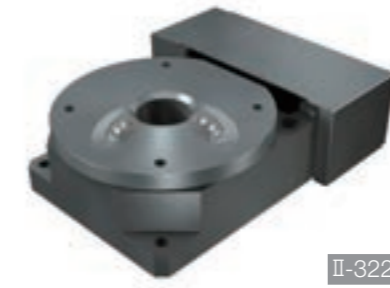

AT

II-322 >>>

Rotation Stage SK

- Crossed Roller Bearings ensure high rigidity and compactness
- Allows smooth, high-accuracy positioning
- Direct mounting of the table or test object reduces labor hours required for design work



Worm gear drive
Rotation



SK...W

II-334 >>>

Micro Precision Positioning Table TM

- Ground ball screw drive realizes ultra-small size with sectional height of 20mm and width of 17mm.
- High positioning accuracy and excellent durability

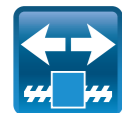

Ball screw drive
Linear



TM

II-190 >>>

Precision Positioning Table TS/CT

- Compact structure with low profile
- Crossed Roller Way guaranteeing high reliability and high accuracy

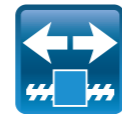

Ball screw drive
Linear



TS

CT

II-208 >>>

Alignment Module AM

- Supports free designing of stage according to your use
- Control tolerance of height within $\pm 10 \mu$ m



Ball screw drive
Alignment



AM

II-342 >>>

Precision Elevating Table TZ

- Unique wedge mechanism ensures compact and high accuracy vertical positioning.
- TZ...X achieving high accuracy and high rigidity through adoption of C-Lube Linear Roller Way Super X



Ball screw drive
Vertical



TZ...H TZ...X

II-356 >>>

A Variety of Models and Variations



Precision Positioning Table TE

TE...B

Ball screw drive



- High-strength aluminum alloy is used for main components
- Light weight, low profile and compact positioning table
- High accuracy positioning
- Long term maintenance free specification with C-Lube built in
- Excellent cost performance

Specification

Model and size	Maximum stroke (mm)	Maximum speed (mm/s)	Ball screw lead (mm)
TE50B	410	800	4, 8
TE60B	600	1 000	5, 10, 20
TE86B	800	1 860	10, 20

Accuracy

Positioning repeatability	○
Positioning accuracy	○
Lost motion	—
Parallelism in table motion A	—
Parallelism in table motion B	○
Attitude accuracy	—
Straightness	—
Backlash	○

See page

II-4



Precision Positioning Table L

TSL...M

Ball screw drive



- Standard type highly-proven in various fields
- Parallel arrangement of Linear Ways with stable performance
- High running accuracy and positioning accuracy
- Many size variations support easy multi-axis system configurations.
- Long term maintenance free specification with C-Lube built in

Specification

Model and size	Maximum stroke (mm)	Maximum speed (mm/s)	Ball screw lead (mm)
TSL 90 M	300	500	5, 10
TSL 120 M	600	500	5, 10
TSL 170 M	500	500	5, 10
TSL 170S M	1 000	500	5, 10
TSL 220 M	1 000	500	5, 10

Accuracy

Positioning repeatability	○
Positioning accuracy	○
Lost motion	—
Parallelism in table motion A	—
Parallelism in table motion B	○
Attitude accuracy	—
Straightness	—
Backlash	○

See page

II-102



Precision Positioning Table TU

TU

Ball screw drive



- Original high rigidity U-shaped track rail adopted
- Various table specifications are available according to your use.
- Slide table with high accuracy and high rigidity in a single structure
- Easy ordering just by specifying the identification number for the required functions and performance

Specification

Model and size	Maximum stroke (mm)	Maximum speed (mm/s)	Ball screw lead (mm)
TU 25	100	400	4
TU 30	230	500	5
TU 40	285	800	4, 8
TU 50	560	1 000	5, 10
TU 60	1 010	1 860	5, 10, 20
TU 86	1 400	1 480	10, 20
TU100	1 140	1 110	20
TU130	1 260	1 110	25

Accuracy

Positioning repeatability	○
Positioning accuracy	○
Lost motion	—
Parallelism in table motion A	—
Parallelism in table motion B	○
Attitude accuracy	—
Straightness	—
Backlash	○

See page

II-32



Precision Positioning Table LH

TSLH...M

Ball screw drive



CTLH...M

(Two-axis specification)

- Component parts from rigorous selection ensure high accuracy and reliability.
- High rigidity and large carrying mass
- High running accuracy and positioning accuracy
- The series including ultra large size with table width of 420mm
- Long term maintenance free specification with C-Lube built in

Specification

Model and size	Maximum stroke (mm)	Maximum speed (mm/s)	Ball screw lead (mm)
TSLH120M	300	500	5, 10
TSLH220M	400	500	5, 10
TSLH320M	500	448	5, 10
TSLH420M	800	448	5, 10
CTLH120M	300 × 300	500	5, 10
CTLH220M	400 × 400	500	5, 10
CTLH320M	500 × 500	448	5, 10

Accuracy

Positioning repeatability	○
Positioning accuracy	○
Lost motion	—
Parallelism in table motion A	○
Parallelism in table motion B	—
Attitude accuracy	—
Straightness	◎
Backlash	◎

See page

II-122

A Variety of Models and Variations



Super Precision Positioning Table TX

TX...M (Single-axis specification)  Ball screw drive
CTX...M (Two-axis specification)  Linear

- Achieved ultimate positioning performance with rolling guide type
- Fully-closed loop control equipped with super high accuracy linear encoder ensuring high accuracy
- Control method selectable according to needs
- Long term maintenance free specification with C-Lube built in

Specification

Model and size	Maximum stroke (mm)	Maximum speed (mm/s)	Ball screw lead (mm)
TX 120M	300	500	5, 10
TX 220M	400	500	5, 10
TX 320M	500	448	5, 10
TX 420M	800	448	5, 10
CTX120M	300 × 200	500	5, 10
CTX220M	400 × 300	500	5, 10

Accuracy

Positioning repeatability	◎
Positioning accuracy	◎
Lost motion	◎
Parallelism in table motion A	◎
Parallelism in table motion B	—
Attitude accuracy	◎
Straightness	◎
Backlash	◎

See page

II-150



Micro Precision Positioning Table TM

TM  Ball screw drive  Linear

- Ground ball screw drive realizes ultra-small size with sectional height of 20mm and width of 17mm.
- High positioning accuracy and excellent durability
- Two types of slide table shapes selectable according to needs
- Super-miniature sensor can be built in.

Specification

Model and size	Maximum stroke (mm)	Maximum speed (mm/s)	Ball screw lead (mm)
TM15	60	75	0.5, 1.0, 1.5
TM15G	50	75	0.5, 1.0, 1.5

Accuracy

Positioning repeatability	○
Positioning accuracy	○
Lost motion	—
Parallelism in table motion A	—
Parallelism in table motion B	—
Attitude accuracy	—
Straightness	—
Backlash	—

See page

II-190



Cleanroom Precision Positioning Table TC

TC...EB  Ball screw drive  Linear

- Optional for use in high cleanliness environment for semiconductor and LCD manufacturing machines
- Light weight, low profile and compact positioning table
- Compatible with cleanliness class 3
- Long term maintenance free specification with C-Lube built in

Specification

Model and size	Maximum stroke (mm)	Maximum speed (mm/s)	Ball screw lead (mm)
TC50EB	200	400	4, 8
TC60EB	500	500	5, 10
TC86EB	800	1 000	10, 20

Accuracy



Positioning repeatability	○
Positioning accuracy	○
Lost motion	—
Parallelism in table motion A	—
Parallelism in table motion B	○
Attitude accuracy	—
Straightness	—
Backlash	○

See page

II-172



Precision Positioning Table TS/CT

TS (Single-axis specification)  Ball screw drive
CT (Two-axis specification)  Linear

- Compact structure with low profile
- Crossed Roller Way guaranteeing high reliability and high accuracy positioning
- Compact design achieved by utilizing wide area of slide table

Specification

Model and size	Maximum stroke (mm)		Maximum speed (mm/s)	Ball screw lead (mm)
	X-axis	Y-axis		
TS 55/ 55	± 7.5		30	1
TS 75/ 75	± 12.5		30	1
TS125/125	± 25		250	1, 2, 5
TS125/220	± 60		250	2, 5
TS220/220	± 60		250	2, 5
TS220/310	± 90		250	2, 5
TS260/350	±125		250	2, 5
CT 55/ 55	± 7.5	± 7.5	30	1
CT 75/ 75	± 12.5	± 12.5	30	1
CT125/125	± 25	± 25	250	1, 2, 5
CT220/220	± 60	± 60	250	2, 5
CT260/350	± 75	±125	250	2, 5
CT350/350	±125	±125	250	2, 5

Accuracy

Positioning repeatability	○
Positioning accuracy	○
Lost motion	—
Parallelism in table motion A	◎
Parallelism in table motion B	○
Attitude accuracy	—
Straightness	—
Backlash	○

See page

II-208

A Variety of Models and Variations

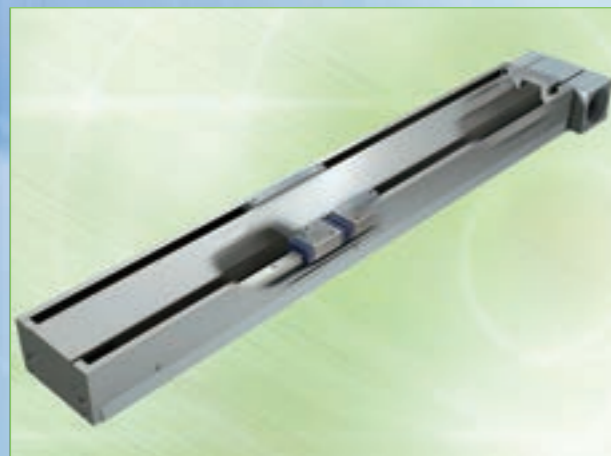

Precision Positioning Table LB

TSLB

Timing belt drive



- Timing belt drive achieves high speed travel at 1,500mm/s.
- Parallel arrangement of Linear Way ensures stable and high operating performance.
- Long stroke up to 1,200mm

Specification

Model and size	Maximum stroke (mm)	Maximum speed (mm/s)	Resolution (mm)
TSLB 90	600	1 500	0.1
TSLB120	1 000	1 500	0.1
TSLB170	1 200	1 500	0.1

Accuracy

Positioning repeatability	△
Positioning accuracy	—
Lost motion	—
Parallelism in table motion A	—
Parallelism in table motion B	△
Attitude accuracy	—
Straightness	—
Backlash	—

See page

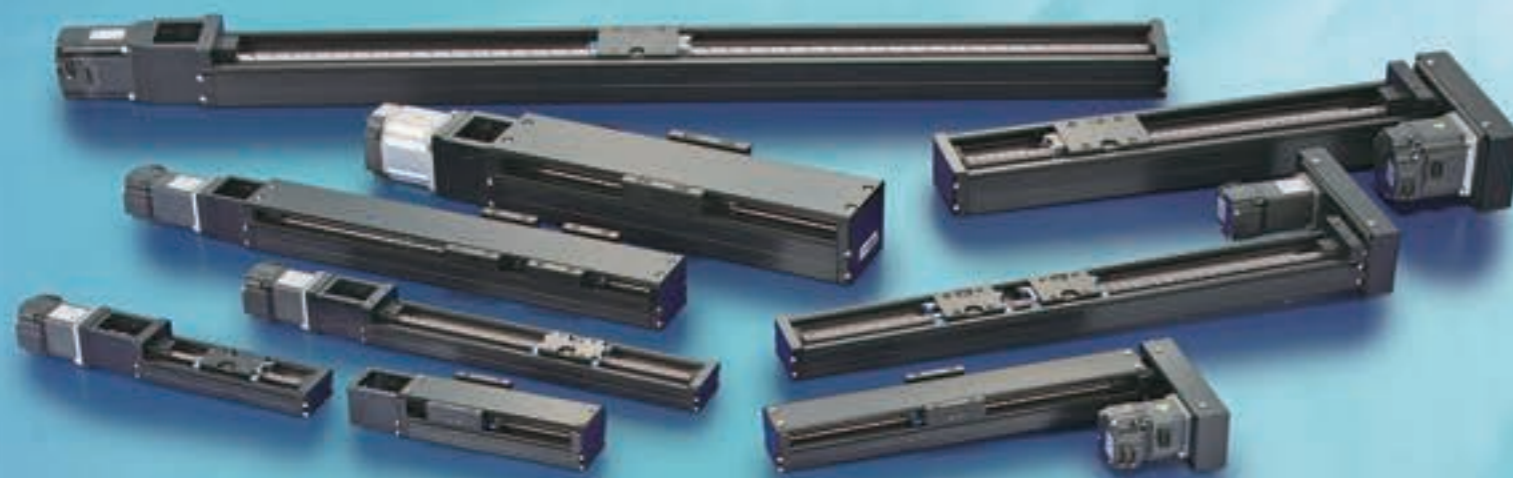
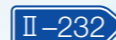

Nano Linear NT

Standard Type

NT...V

Linear motor drive



- Pursuing ultimate compactification
- Very low profile of NT38V: only 11mm
- A wide variety of selections support optimal choice according to your use.
- High acceleration / deceleration ensuring highly responsive positioning
- Two-axis combination of X and Y

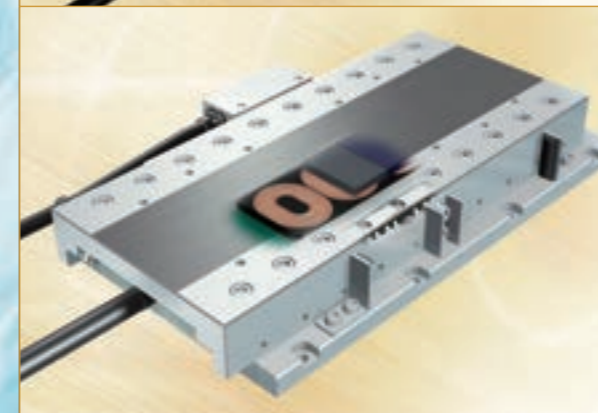

High Accuracy Type

NT...H

Linear motor drive



- Pursuing ultimate compactification
- High attitude accuracy
- High speed stability
- Simple system configuration



Pick and Place Unit

NT...XZ
NT...XZH

Linear motor drive



- Pursuing ultimate compactification
- High-tact positioning
- Ultrathin and space saving
- Operation monitoring function

Specification

Model and size	Maximum stroke (mm)	Maximum speed (mm/s)	Resolution (μm)
NT38V	18	500	0.1, 0.5
NT55V	65	1 300	0.1, 0.5
NT80V	120	1 300	0.1, 0.5
NT88H	65	400	0.01, 0.05
NT80XZ	45	1 300	0.1, 0.5
NT90XZH	25	1 300	0.1, 0.5

Accuracy

Item	NT...V	NT...H	NT...XZ
Positioning repeatability	◎	◎	◎
Positioning accuracy	—	◎	—
Lost motion	—	—	—
Parallelism in table motion A	—	◎	—
Parallelism in table motion B	—	—	—
Attitude accuracy	—	◎	—
Straightness	—	◎	—
Backlash	—	—	—

See page



A Variety of Models and Variations



Alignment Stage SA

Linear motor drive
SA...DE   Linear Alignment

- Slim and compact design with sectional height of 3 axes, X, Y and θ being only 52mm (SA65DE)
- X- and Y-axis: 0.1 μm , θ -axis: excellent resolution as high as 0.36 sec (SA120DE)
- Free and independent combination of X, Y and θ

Specification

Model and size	Maximum stroke Maximum operating angle	Maximum speed	Resolution
SA 65 DE/X	10 (mm)	500 (mm/s)	0.1, 0.5 (μm)
SA120 DE/X	20 (mm)	800 (mm/s)	0.1, 0.5 (μm)
SA 200 DE/X	20 (mm)	800 (mm/s)	0.1, 0.5 (μm)
SA 65 DE/S	50 (degree)	720 (degree/s)	0.64 (s)
SA120 DE/S	60 (degree)	400 (degree/s)	0.36 (s)
SA200 DE/S	280 (degree)	270 (degree/s)	0.25 (s)

Accuracy

Positioning repeatability	◎
Positioning accuracy	—
Lost motion	—
Parallelism in table motion A	—
Parallelism in table motion B	—
Attitude accuracy	—
Straightness	—
Backlash	—

See page

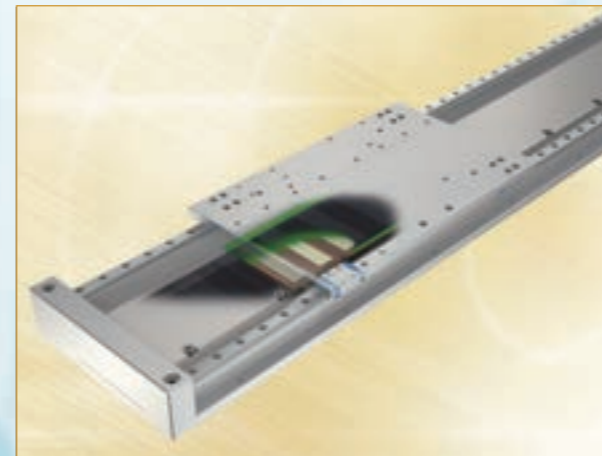

Linear Motor Table LT

Compact Type
LT...CE  Linear motor drive

- Compact
- High static stability
- High speed stability
- High acceleration / deceleration and high response
- Long term maintenance free specification with C-Lube built in

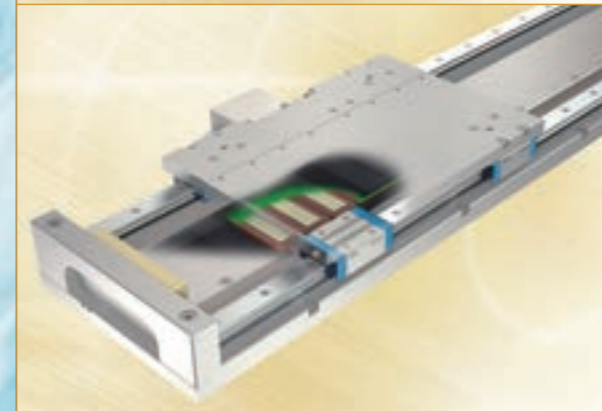

Long Stroke Type
LT...LD  Linear motor drive

- Super long stroke
- High static stability
- High speed stability
- Both high speed and high resolution are achieved.
- Long term maintenance free specification with C-Lube built in

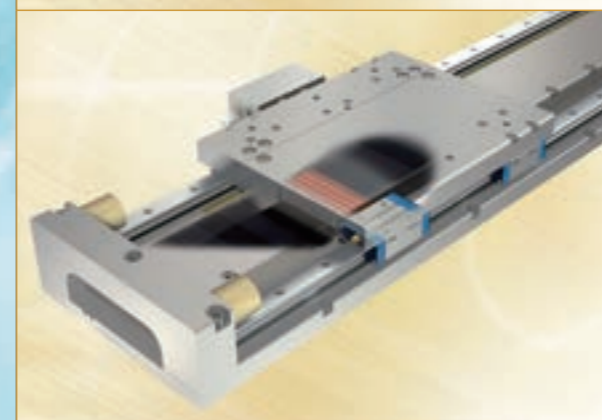

High Thrust Type
LT...H  Linear motor drive

- High thrust
- High acceleration / deceleration, high response and smooth operations
- High static stability
- Air-cooling capable
- Long term maintenance free specification with C-Lube built in

Specification

Model and size	Maximum stroke (mm)	Maximum speed (mm/s)	Resolution (μm)
LT100CE	1 000	2 000	0.1, 0.5, 1.0
LT150CE	1 200	2 000	0.1, 0.5, 1.0
LT130LD	2 760	3 000	0.1, 0.5, 1.0
LT170LD	2 720	3 000	0.1, 0.5, 1.0
LT170H	2 670	1 500	0.1, 0.5, 1.0

Accuracy

Item	LT...CE	LT...LD	LT...H
Positioning repeatability	◎	◎	◎
Positioning accuracy	—	—	—
Lost motion	—	—	—
Parallelism in table motion A	—	—	—
Parallelism in table motion B	—	—	—
Attitude accuracy	—	—	—
Straightness	—	—	—
Backlash	—	—	—

See page

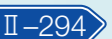

A Variety of Models and Variations

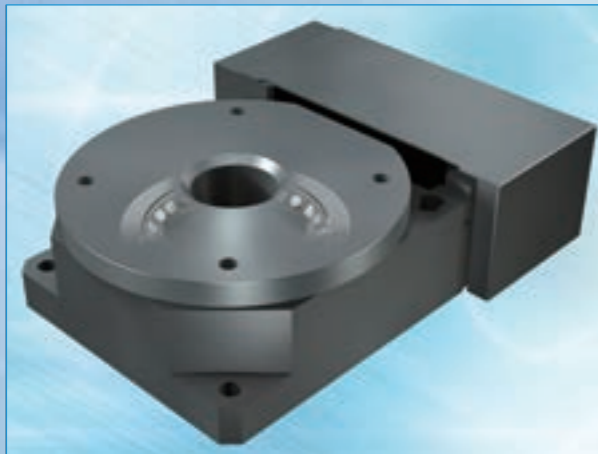

Alignment Table AT

AT

Ball screw drive



Alignment

- High accuracy positioning ensuring precise angle correction
- Crossed Roller Bearing ensures high rigidity and compactness.
- High positioning repeatability
- A series of 3 sizes

Specification

Model and size	Maximum operating angle (degree)	Ball screw lead (mm)	Rotator resolution (μm)
AT120	± 5	1	1
AT200	± 5	1	1
AT300	± 10	2	2

Accuracy

Positioning repeatability	◎
Positioning accuracy	—
Lost motion	—
Parallelism in table motion A	—
Parallelism in table motion B	—
Attitude accuracy	—
Straightness	—
Backlash	—

See page

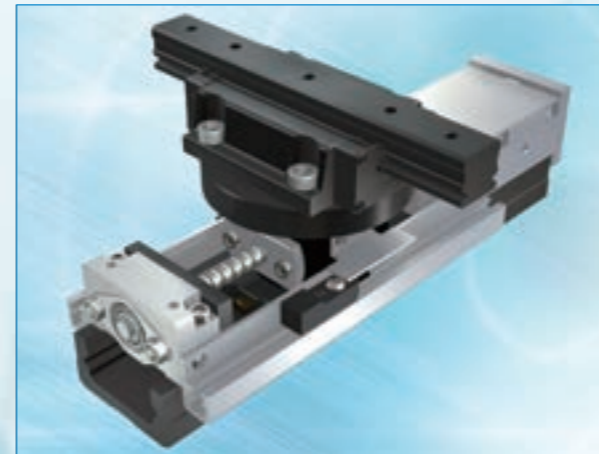

Alignment Module AM

AM

Ball screw drive



Alignment

- Supports free designing of stage according to your use
- Control tolerance of height within $\pm 10\mu\text{m}$
- Variety of positioning operations in combination of X, Y, and θ
- Ideal for large size equipment
- High accuracy, high rigidity, and high reliability

Specification

Model and size	Maximum stroke (mm)	Length of track rail (mm)	Ball screw lead (mm)
AM25	30	130	4
AM40	30	180	4
AM60	90	290	5
AM86	120	390	5

Accuracy

Positioning repeatability	○
Positioning accuracy	○
Lost motion	—
Parallelism in table motion A	—
Parallelism in table motion B	○
Attitude accuracy	—
Straightness	—
Backlash	○

See page

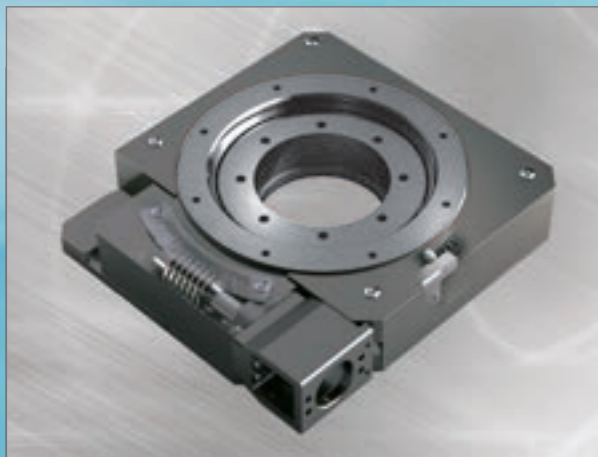

Rotation Stage SK

SK...W

Worm gear drive



Rotation

- Crossed Roller Bearings ensure high rigidity and compactness
- Allows smooth, high-accuracy positioning
- Direct mounting of the table or test object reduces labor hours required for design work

Specification

Model and size	Table diameter (mm)	Operating angle range (degree)	Maximum number of table revolutions (min^{-1})
SK120W	115	360	5
SK120W/SC	120	320	

Accuracy

Positioning repeatability	○
Positioning accuracy	◎
Lost motion	△
Parallelism in table motion A	—
Parallelism in table motion B	—
Attitude accuracy	—
Straightness	—
Backlash	△

See page

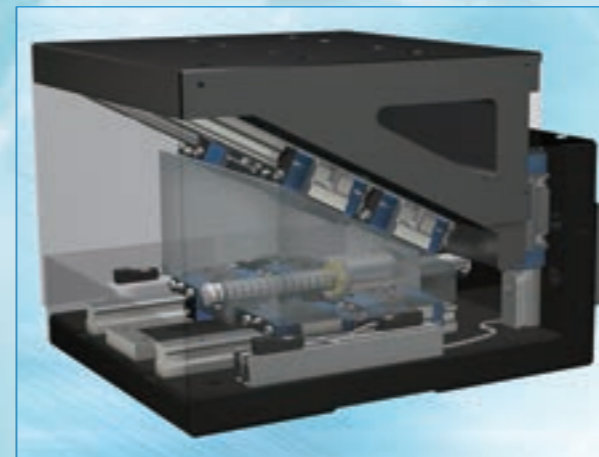
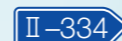

Precision Elevating Table TZ

TZ

Ball screw drive



Linear

- Unique wedge mechanism ensures compact and high accuracy vertical positioning.
- TZ...X achieving high accuracy and high rigidity through adoption of C-Lube Linear Roller Way Super MX
- Linear encoder mountable
- Long term maintenance free with C-Lube built in
- A series of two types of reduction ratios

Specification

Model and size	Maximum stroke (mm)	Maximum speed (mm/s)	Ball screw lead (mm)
TZ120X	10	100	4
TZ200H	24	125	5
TZ200X	24	125	5

Accuracy

Positioning repeatability	○
Positioning accuracy	○
Lost motion	○
Parallelism in table motion A	—
Parallelism in table motion B	—
Attitude accuracy	○
Straightness	—
Backlash	—

See page



For light weight and low profile innovative tables

Precision Positioning Table TE

TE...B



High-strength aluminum alloy is used for main components. Light weight and compact structure with slide table assembled inside the U-shaped bed!

● Mass unit: kg

Bed width(mm)	TU	TE...B
50	1.8	0.52
60	3.3	1.0
86	10.9	3.7

The value shows the mass of the entire table with 1 standard table.

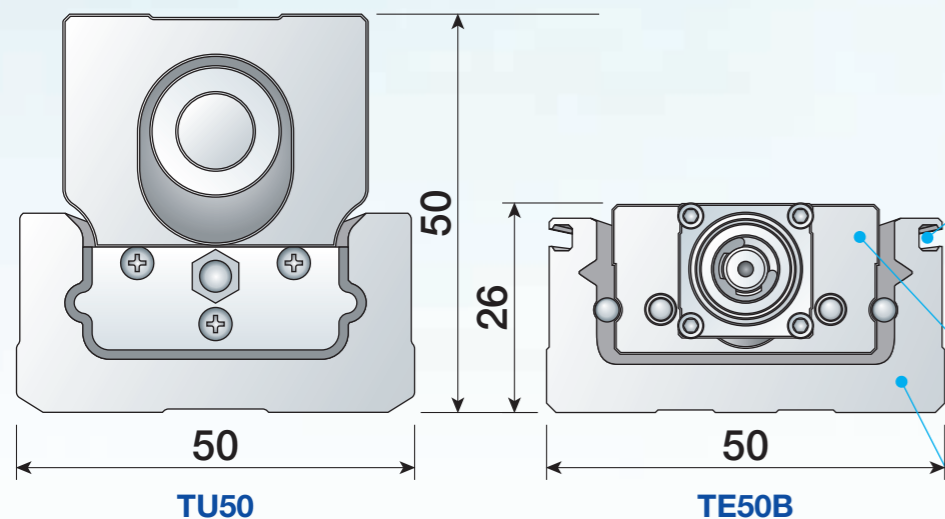
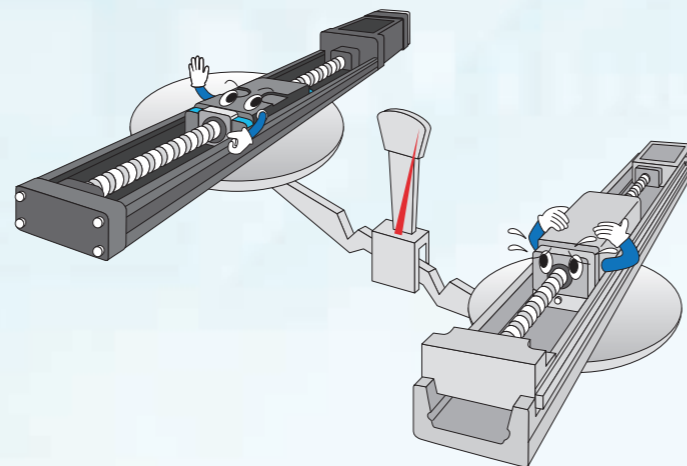

Respective sensors to be attached directly into the mounting groove

Slide table and linear motion rolling guide integrated in a single structure to ensure low profile and compact design!

Ultra light weight achieved through the use of slide table and bed made of high-strength aluminum alloy!

For ultimate compactification

Micro Precision Positioning Table TM

TM



Ground ball screw specification realizes ultra-small size with sectional height of 20mm and width of 17mm.

Micro Linear Way L with track rail width of 2mm is adopted in the table guiding parts, and miniature ball screw with screw diameter of 2mm is used in the feeding mechanism. The unparalleled low cross sectional height in the ground ball screw drive is achieved.

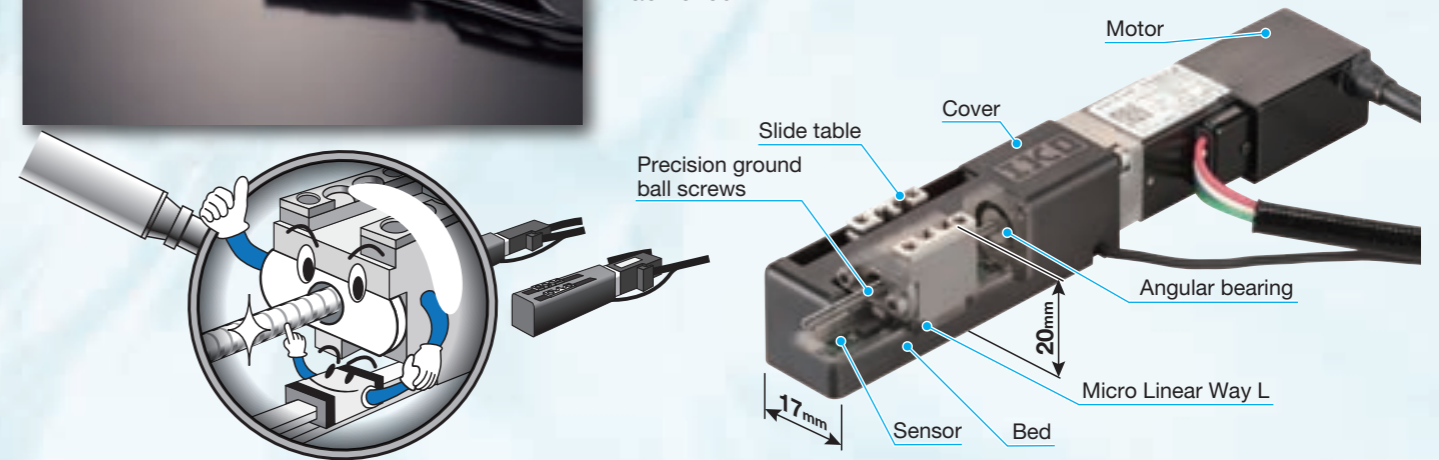

Nano Linear NT

NT...V



Pursuing ultimate compactification NT38V10, the smallest in the series, is only 11mm in sectional height, 38mm in table width and 62mm in entire length.

The occupied space is not increased even when tables are layered in X and Y, so further miniaturization of the positioning mechanism is promoted.

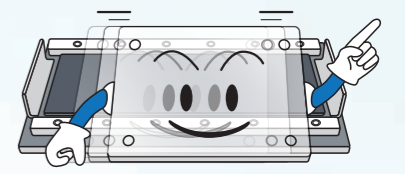

Model	NT...V						
	NT38V10	NT38V18	NT55V25	NT55V65	NT80V25	NT80V65	NT80V120
Model and size							
Sectional dimension							

For higher accuracy

Super Precision Positioning Table TX

TX...M, CTX...M



Super high positioning accuracy and resolution guaranteed with an onboard super high accuracy linear encoder!

Adoption of C-Lube Linear Roller Way Super MX ensures ultimate running performance. Fully-closed loop control is established by super high resolution linear encoder to ensure high positioning accuracy over the whole stroke length.

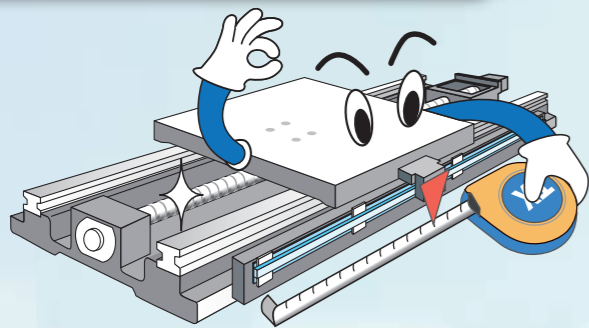
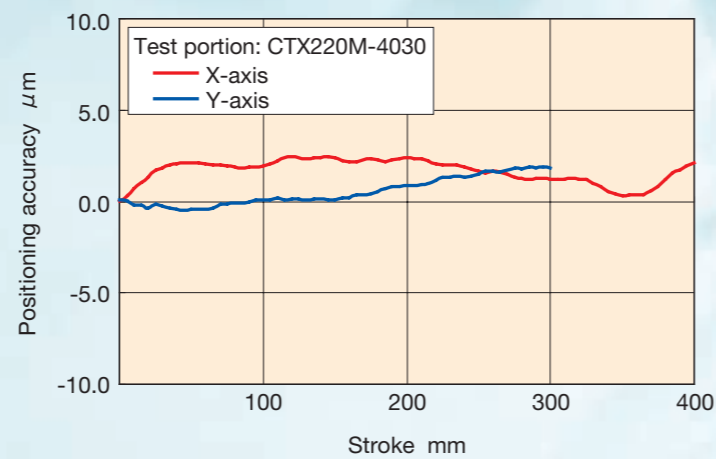

Nano Linear NT

NT...H



High attitude accuracy is realized!

Combination of parts processed with high accuracy and Anti-Creep Cage Crossed Roller Way realizes attitude accuracy of 5 sec or less. Variations in attitude due to movement is minimized, which ensures high positioning repeatability.

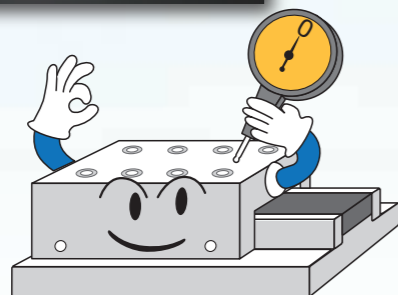
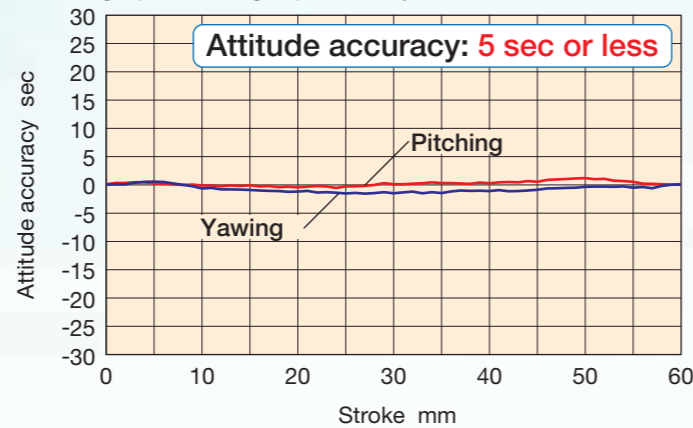

For attaining both high accuracy positioning and high speed

Linear Motor Table LT

LT...LD



Direct drive enables both high-precision positioning and high speed.

Supports high speed operation required for long stroke motion. It is possible to perform high-speed motion of up to 3,000mm/s.

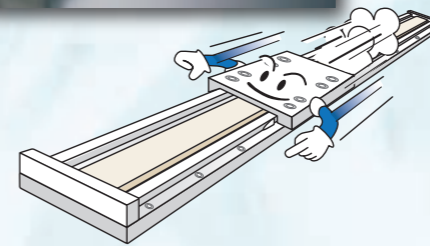
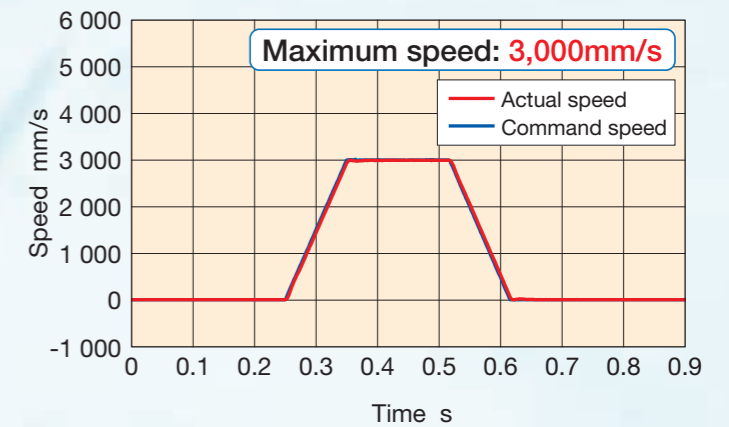

For high speed stability

Linear Motor Table LT

LT...CE, LT...LD, LT...H

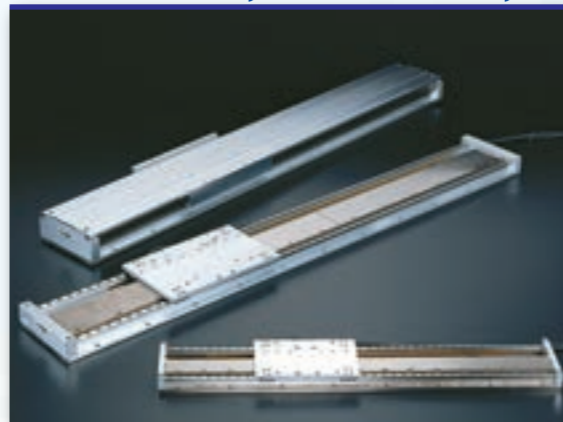

Direct drive and advanced servo technology has achieved high speed stability.

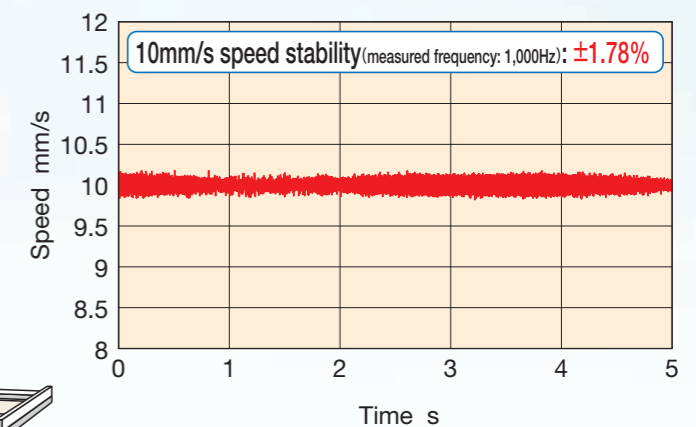

For choosing from a wide variety of options

Easy ordering is possible right now just by specifying the identification number for the required functions and performance!

Precision Positioning Table TU

TU



Shape of slide table

Two types of shape are available according to needs.

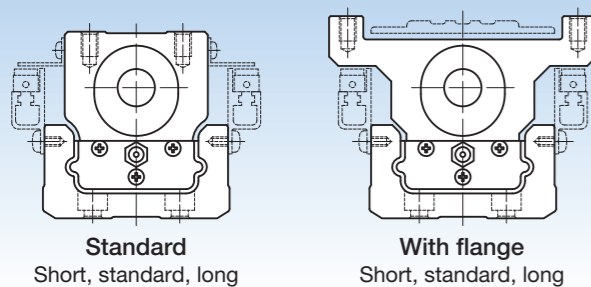

Number of slide tables

Two slide tables can be mounted on the track rail depending on the applied load and the moment.

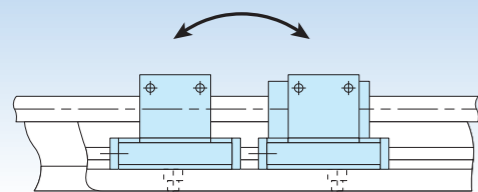

Type and lead of ball screw

Rolled ball screw or ground ball screw can be selected according to the required accuracy. Ball screw lead is also selectable.

Precision Positioning Table TE

TE...B



Motor folding back specification

Shortening the overall length of the table will contribute to space-saving.

With bridge cover

A specification with bridge cover is available for preventing foreign matter from falling onto the table.

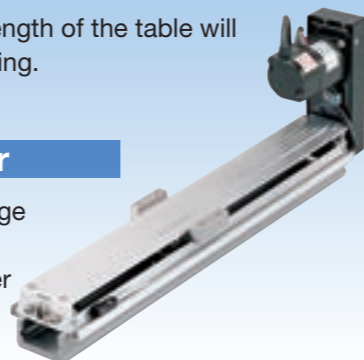

Table with bellows

A specification with bellows is available for preventing foreign matter from intruding into the inside of the table.



Black chrome surface treatment

Black permeable film is applied on the surface of slide table and ball screw to improve corrosion resistance.

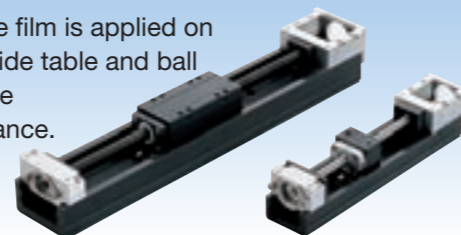

For clean environment applications

Cleanroom Precision Positioning Table TC

TC...EB



Cleanliness class 3 is achieved!

Stainless sheet with excellent corrosion resistance and side cover seal up drive parts and slide table guiding parts. Stainless sheet is pressed onto the side cover by resin roller within the slide table. The structure which ensures proper attraction by the strong magnet sheet prevents dust from generating to the surrounding of the table by air suction from the sealed internal space.

TC50EB150

(Ball screw lead: 4mm)

Stroke length : 50mm
Speed : 200mm/s
Suction amount : 5L/min

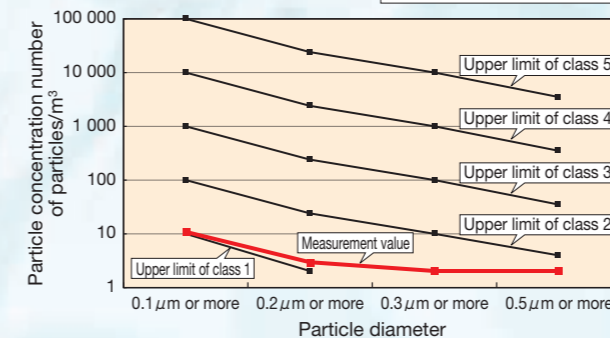

TC50EB300

(Ball screw lead: 8mm)

Stroke length : 200mm
Speed : 400mm/s
Suction amount : 10L/min

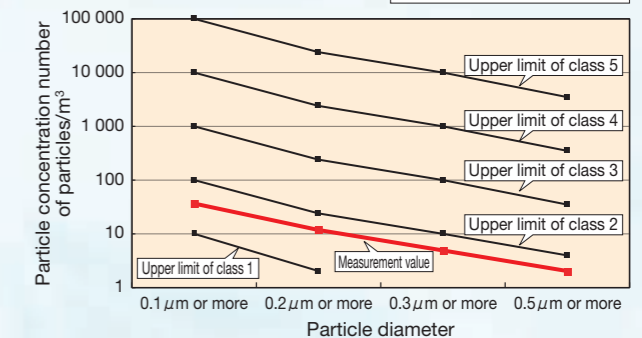

TC60EB300

(Ball screw lead: 10mm)

Stroke length : 200mm
Speed : 500mm/s
Suction amount : 30L/min

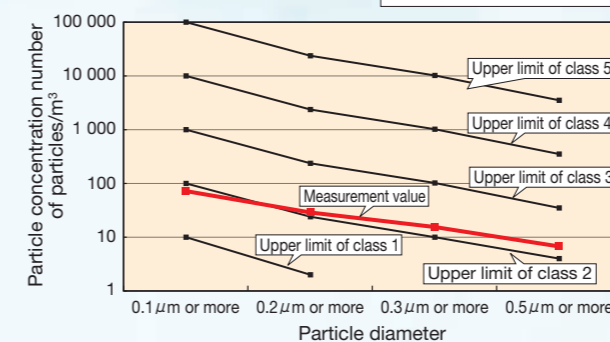

TC60EB600

(Ball screw lead: 10mm)

Stroke length : 500mm
Speed : 500mm/s
Suction amount : 30L/min

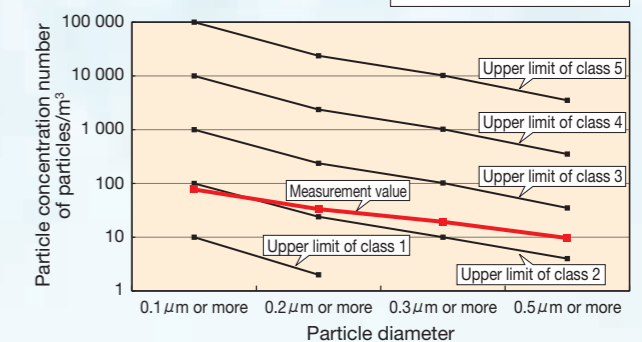

TC86EB640

(Ball screw lead: 20mm)

Stroke length : 200mm
Speed : 1 000mm/s
Suction amount : 70L/min

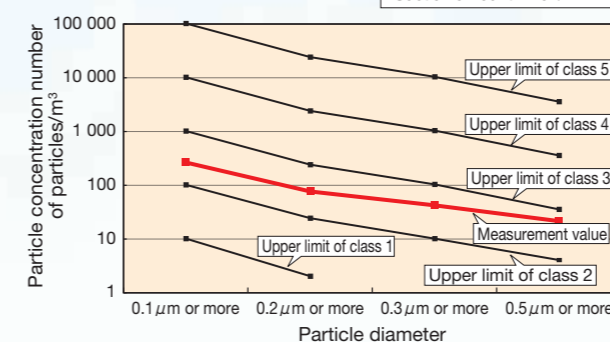

TC86EB940

(Ball screw lead: 20mm)

Stroke length : 800mm
Speed : 560mm/s
Suction amount : 40L/min

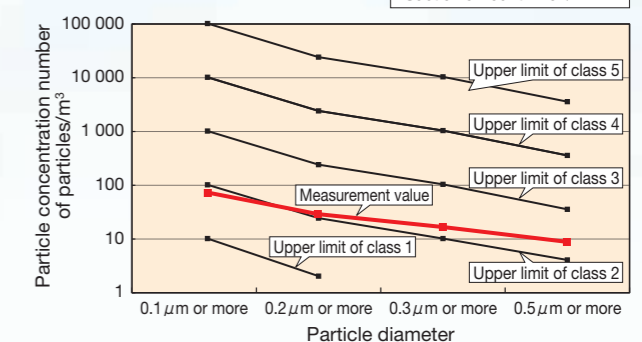

For maintenance free



Original and world's first structure with **[C-Lube]**

C-Lube integrated

Lubrication oil is carried through circulation of rolling elements

The lubrication oil is supplied directly to the rolling elements, not to the track rail.
When rolling elements make contact with the capillary lubricating element integrated with the circulation path of slide unit rolling elements, the lubrication oil is supplied to surfaces of rolling elements and carried to the loading area through circulation of rolling elements.
This results in adequate lubrication oil being properly maintained in the loading area and lubrication performance will last for a long time.

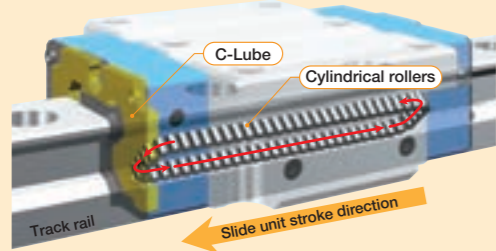

Lubrication oil is directly supplied to surfaces of the rolling elements

The surface of capillary lubricating element is always covered with the lubrication oil.
Lubrication oil is continuously supplied to the surface of rolling elements by surface tension in the contact of capillary lubricating element surface and rolling elements.
On the surface of capillary lubricating element with which the rolling elements make contact, new lubrication oil is always supplied from the other sections.

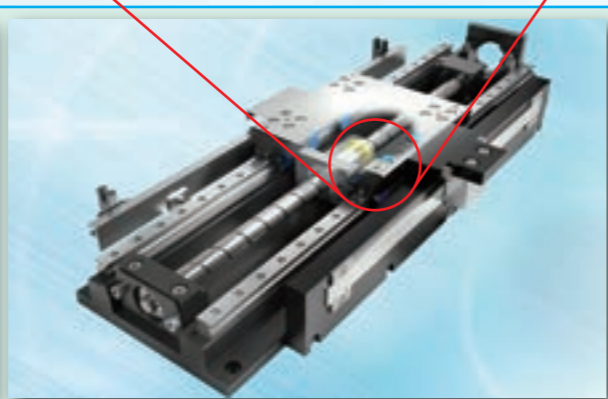
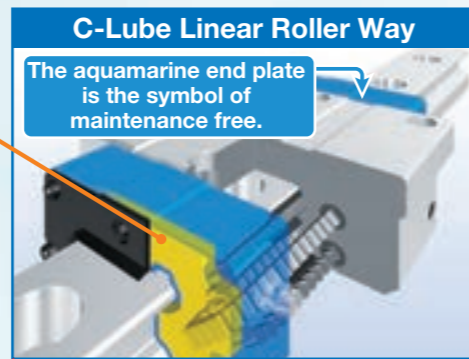
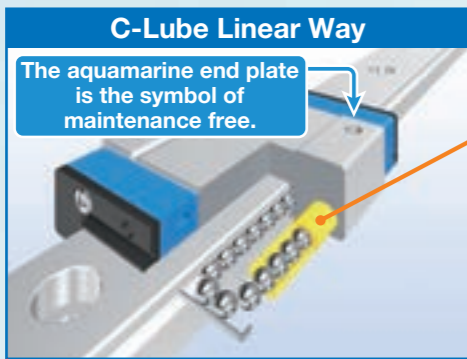
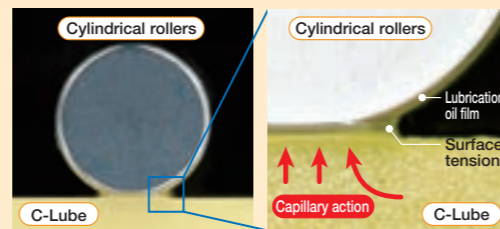

- Precision Positioning Table TE
- Precision Positioning Table L
- Precision Positioning Table LH
- Cleanroom Precision Positioning Table TC
- Precision Elevating Table TZ
- Super Precision Positioning Table TX
- Nano Linear NT
- Alignment Stage SA
- Linear Motor Table LT

Series with **[C-Lube]** built in

For a wider variety of needs

Extensive experience in special stages will help us precisely address your particular needs such as stages related to various axis configurations. If needed, please contact IKO.

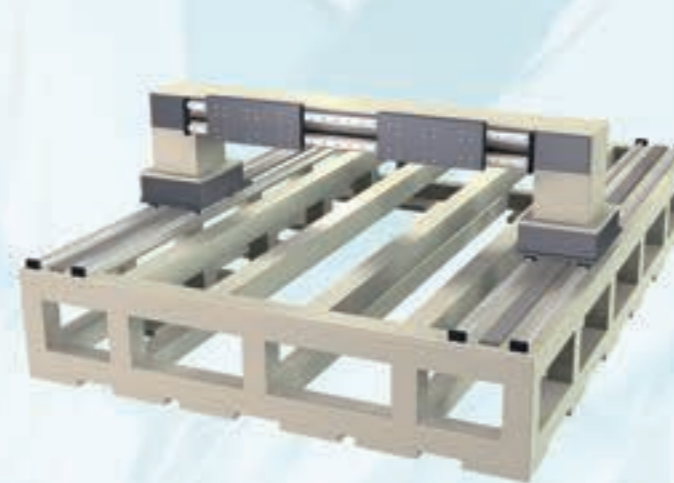

▲ Liquid crystal substrate manufacturing equipment



▲ Liquid crystal substrate manufacturing equipment



▲ Electronic parts inspection equipment



▲ Liquid crystal substrate inspection equipment

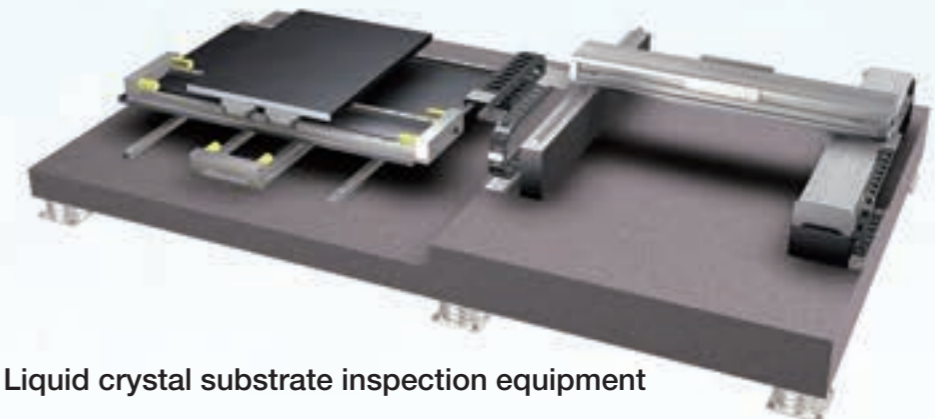

▲ Liquid crystal substrate inspection equipment