

**C-Lube Linear Way ML
Linear Way L**

ML • LWL

C-Lube Linear Way ML

ML



The aquamarine end plate is the symbol of maintenance free.



Points

● Extremely small size realized by simple structure

For details ▶ P.I-19

Super small-size linear motion rolling guide produced by two-row four-point contact simple structure and original small sizing technology. The track rail width of LWL1, the smallest size, is only 1mm.

● Wide range of variations for your needs

For details ▶ P.I-25

The slide unit shape can be selected from two types, the standard type and the wide type suited for single-row track rail uses, and there are four types with different lengths of slide unit with same section. Furthermore, the track rail has the variation of standard type and tapped rail type with the screw thread implanted, allowing you to select an optimal product for the specifications of your machine and device.

● Ball retained type for easy operation

The slide unit of ball retained type incorporates the ball retaining band, which prevents the ball from dropping down when the slide unit is removed from the track rail.

This safety structure brings you an easy operation to the machines / equipment.

● Stainless steel selections for excellent corrosion resistance

For details ▶ P.I-43

Stainless steel highly corrosion-resistant is used as the basic specification, so that the products are suitable for applications where rust prevention oil is not preferred, such as in cleanroom environment. High carbon steel products suited to general purposes are also provided.

● Widely supports special environment uses

For details ▶ P.I-33

C-Lube Linear Way ML for special environment uses are provided as a series. Increasingly varied special environment uses are supported, such as by high-speed / low-noise specifications by combining silicon nitride ceramics and low dust-generation specifications.

Identification Number and Specification

Example of an identification number

The specifications of ML(F) and LWL(F) series are indicated by the identification number. Indicate the identification number, consisting of a model code, dimensions, a part code, a material code, a preload symbol, a classification symbol, an interchangeable code, and any supplemental codes for each specification to apply.

Non-interchangeable specification	1	2	4	5	6	3	7	8	9	10	11
Assembled set	ML	C	12	C1	R200			T ₁	P		/U
Interchangeable specification											
Single slide unit	ML	C	12	C1				T ₁	P	S1	/U
Single track rail ⁽¹⁾	LWL		12		R200	B			P	S1	
Assembled set	ML	C	12	C1	R200			T ₁	P	S1	/U

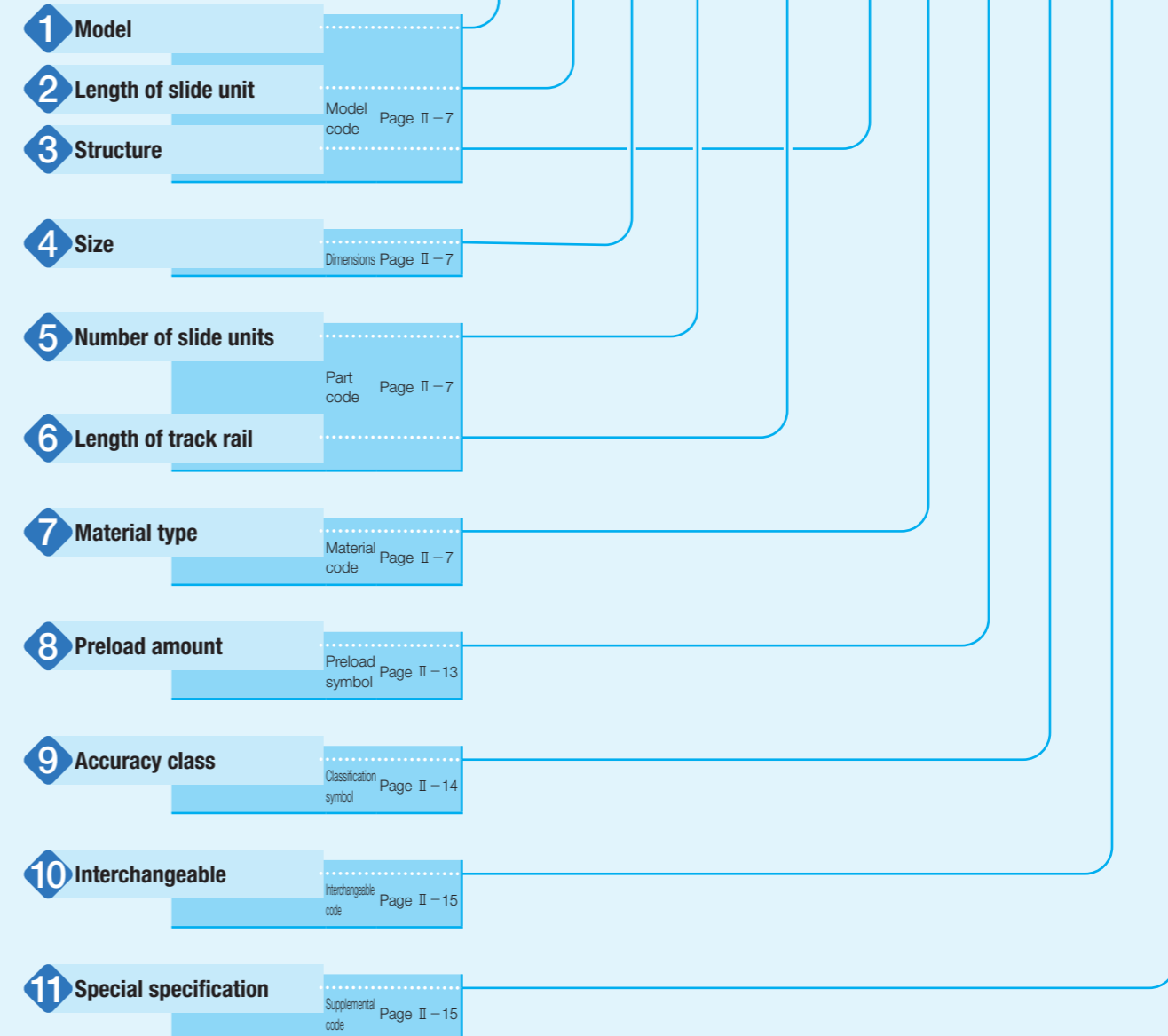

Note ⁽¹⁾ Indicate "LWL...B" or "LWLF...B" for the model code of the single track rail regardless of the series and the combination of slide unit models.
 1N=0.102kgf=0.2248lbs.
 1mm=0.03937inch

Identification Number and Specification — Model · Length of Slide Unit ·

1 Model

C-Lube Linear Way ML (ML(F) series) Standard type : ML
Wide type : MLF

Linear way L ⁽¹⁾ (LWL (F) series) Standard type : LWL
Wide type : LWLF

For applicable models and sizes, see Table 2.1 and Table 2.2.
Indicate "LWL...B" or "LWLF...B" for the model code of the single track rail regardless of the series and the combination of slide unit models.

Note ⁽¹⁾ This model has no built-in C-Lube.

2 Length of slide unit

Short : C For applicable models and sizes, see Table 2.1 and Table 2.2.
Standard : No symbol
Long : G
Extra long : L

3 Structure

Table 1.1 Structure of ML and LWL

Model	Types and sizes of track rails	Structure	
ML	Standard rail specification Size: 5~25	Ball retained type : No symbol	
	Tapped rail specification Size: 3 Size: 5, 7, 9	Ball non-retained type : No symbol Ball retained type : N	
LWL	Standard rail specification	Ball retained type : B	
	Tapped rail specification	Mounting from bottom Size: 2, 3	Ball non-retained type : No symbol
		Mounting from lateral Size: 5, 7, 9	Ball retained type : N
	Solid rail specification Size: 1	Ball non-retained type : Y	
	Solid rail specification Size: 1	Ball non-retained type : No symbol	

Table 1.2 Structure of MLF and LWLF

Model	Types of track rails	Structure
MLF	Standard rail specification Size: 6	Ball non-retained type : No symbol
	Tapped rail specification Size: 10~42	Ball retained type
LWLF	Standard rail specification	Size: 6 Ball non-retained type : N
		Size: 10~18 Ball retained type
	Tapped rail specification	Size: 4, 6 Ball non-retained type : No symbol
		Size: 10~42 Ball retained type : B
	Size: 2 Ball non-retained type : No symbol	
	Size: 6 Ball non-retained type : N	
	Size: 10~18 Ball retained type	

For applicable models and sizes, see Table 2.1 and Table 2.2.

4 Size

Standard type 1, 2, 3, 5, 7, 9, 12, 15, 20, 25 For applicable models and sizes, see Table 2.1 and Table 2.2.
Wide type 2, 4, 6, 10, 14, 18, 24, 30, 42

5 Number of slide units

: C○ For an assembled set, indicates the number of slide units assembled on a track rail. For a single slide unit, only "C1" is specified.

6 Length of track rail









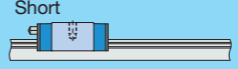

: R○ Indicate the length of track rail in mm.
For standard and maximum lengths, see Table 3.1, Table 3.2, and Table 3.3.

7 Material type

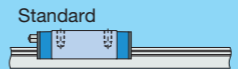
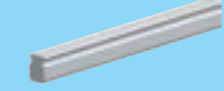
Stainless steel made : No symbol For applicable models and sizes, see Table 2.1 and Table 2.2.
High carbon steel made : CS

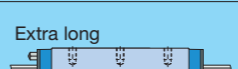
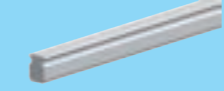
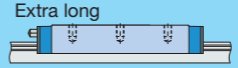





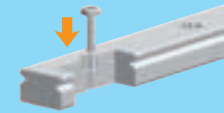

Structure · Size · Number of Slide Unit · Length of Track Rail · Material Type —

Table 2.1 Models and sizes of standard type ML(F) and LWL(F) series

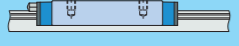
Types of track rails	Material type	Length of slide unit	Structure	Model	Size											
					1	2	3	5	7	9	12	15	20	25		
Standard rail specification 	Stainless steel made	Short 	Ball retained type	MLC	-	-	-	○	○	○	○	○	○	○	○	○
		LWLC...B		-	-	-	○	○	○	○	○	○	○	○		
		ML		-	-	-	○	○	○	○	○	○	○	○		
		LWL...B		-	-	-	○	○	○	○	○	○	○	○		
Tapped rail specification Mounting from bottom 	Stainless steel made	Long 	Ball retained type	MLG	-	-	-	-	○	○	○	○	○	○	○	
		LWLG...B		-	-	-	-	○	○	○	○	○	○			
		MLL		-	-	-	-	-	○	○	○	-	-			
		LWL...BCS		-	-	-	-	-	○	○	○	○	-			
Tapped rail specification Mounting from lateral 	High carbon steel made	Standard 	Ball retained type	LWL...Y	○	-	-	-	-	-	-	-	-	-	-	
		Standard 		Ball non-retained type	MLC	-	-	○	-	-	-	-	-	-	-	
		LWLC			-	-	○	-	-	-	-	-	-	-		
		Solid rail specification 		Stainless steel made	Long 	Ball retained type	MLC...N	-	-	-	○	○	○	-	-	-
LWLC...N	-		-		-		○	○	○	-	-	-				
ML	-		-		○		-	-	-	-	-	-	-			
LWL	-		○		○		-	-	-	-	-	-	-			
Tapped rail specification Mounting from lateral 	Stainless steel made	Standard 	Ball retained type	ML...N	-	-	-	○	○	○	-	-	-	-		
		LWL...N		-	-	-	○	○	○	-	-	-				
Solid rail specification 	Stainless steel made	Extra long 	Ball retained type	MLG...N	-	-	-	-	○	○	-	-	-	-		
		LWLG...N		-	-	-	-	○	○	-	-	-				
Tapped rail specification Mounting from lateral 	Stainless steel made	Standard 	Ball non-retained type	LWL...Y	○	-	-	-	-	-	-	-	-	-		
		Standard 		Ball non-retained type	LWL	○	-	-	-	-	-	-	-	-		

Remark: For the models indicated in , the interchangeable specification is available.

Table 2.2 Models and sizes of wide type ML(F) and LWL(F) series

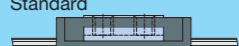
Types of track rails	Material type	Length of slide unit	Structure	Model	Size																			
					2	4	6	10	14	18	24	30	42											
Standard rail specification 	Stainless steel made	Short 	Ball retained type	MLFC	-	-	-	○	○	○	○	○	○	Ball non-retained type	MLFC	-	-	○	-	-	-	-	-	
			LWLF...B	-	-	-	○	○	○	○	○	○	LWLF		-	-	○	-	-	-	-	-		
		Standard 	Ball retained type	MLF	-	-	-	○	○	○	○	○	○	Ball non-retained type	MLF	-	-	○	-	-	-	-	-	
			LWLF...B	-	-	-	○	○	○	○	○	○	LWLF		-	○	○	-	-	-	-	-		
		Long 	Ball retained type	MLFG	-	-	-	-	○	○	○	○	○	Ball non-retained type	MLFG	-	-	-	-	-	-	-	-	
			LWLF...B	-	-	-	-	-	-	-	-	-	LWLF		-	○	○	-	-	-	-	-		
	High carbon steel made	Standard 	Ball retained type	LWLF...BCS	-	-	-	-	-	○	○	○	○											
			Stainless steel made	Short 	Ball retained type	MLFC...N	-	-	-	○	○	○	-	-	-	Ball non-retained type	MLFC...N	-	-	○	-	-	-	-
					LWLF...N	-	-	-	○	○	○	-	-	-	LWLF...N		-	-	○	-	-	-	-	
				Standard 	Ball retained type	MLF...N	-	-	-	○	○	○	-	-	-	Ball non-retained type	MLF...N	-	-	○	-	-	-	-
LWLF...N	-	-	-		○	○	○	-	-	-	LWLF...N	-	-	○	-		-	-	-					
Tapped rail specification Mounting from bottom 	Stainless steel made	Long 	Ball retained type	MLFG...N	-	-	-	-	○	○	-	-	-	Ball non-retained type	MLFG...N	-	-	-	-	-	-	-		
			LWLF...N	-	-	-	-	-	-	-	-	-	LWLF		○	-	-	-	-	-	-			
		Standard 	Ball non-retained type	LWLF	○	-	-	-	-	-	-	-	-	-										

Remark: For the models indicated in , the interchangeable specification is available.

Table 3.1 Standard and maximum length of stainless steel track rail (Standard type)

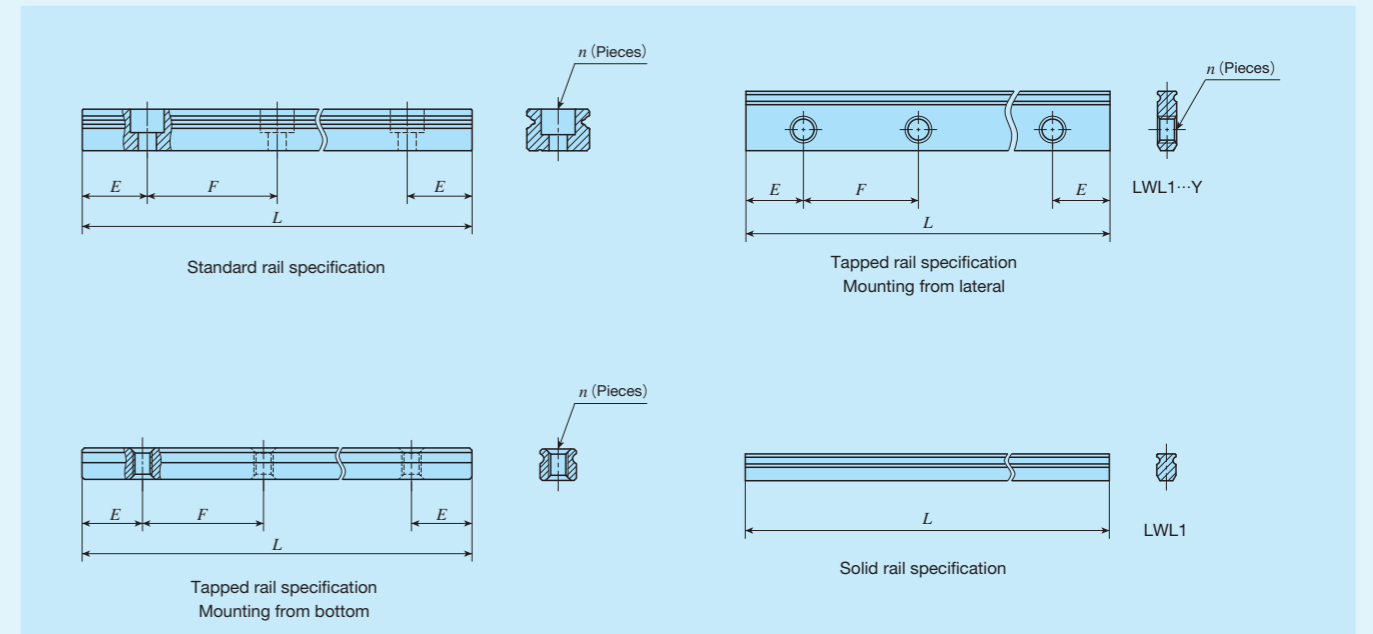

unit: mm

Item	Identification number						
	LWL1...Y	LWL1	LWL2	ML 3 LWL3	ML 5 ⁽⁴⁾ LWL5...B ⁽⁴⁾	ML 7 ⁽⁴⁾ LWL7...B ⁽⁴⁾	
Standard length L (n)	18 (3)	18 (-)	32 (4)	30 (3)	60 (4)	60 (4)	
	30 (5)	30 (-)	40 (5)	40 (4)	90 (6)	90 (6)	
	42 (7)	42 (-)	56 (7)	60 (6)	105 (7)	120 (8)	
			80 (10)	80 (8)	120 (8)	150 (10)	180 (12)
Pitch of mounting holes F	6	-	8	10	15	15	
E	3	-	4	5	7.5	7.5	
	Standard E or higher dimensions ⁽¹⁾ below	2.5	-	2.5	3	4	4.5
Maximum length ⁽²⁾	102	102	104 (200)	150 (300)	210 (510)	300 (990)	
Maximum number of butt-jointing track rail ⁽³⁾	-	-	-	-	5	7	
Maximum length of butt-jointing track rail ⁽³⁾	-	-	-	-	915	1 905	
Item	Identification number						
	ML 9 ⁽⁴⁾ LWL9...B ⁽⁴⁾	ML 12 LWL12...B	ML 15 LWL15...B	ML 20 LWL20...B	ML 25 LWL25...B		
Standard length L (n)	60 (3)	100 (4)	160 (4)	180 (3)	240 (4)		
	80 (4)	150 (6)	240 (6)	240 (4)	300 (5)		
	120 (6)	200 (8)	320 (8)	360 (6)	360 (6)		
	160 (8)	275 (11)	440 (11)	480 (8)	480 (8)		
	220 (11)	350 (14)	560 (14)	660 (11)	660 (11)		
280 (14)	475 (19)	680 (17)	840 (14)	900 (15)			
Pitch of mounting holes F	20	25	40	60	60		
E	10	12.5	20	30	30		
	Standard E or higher dimensions ⁽¹⁾ below	4.5	5	5.5	8	9	
Maximum length ⁽²⁾	860 (1 200)	1 000 (1 450)	1 000 (1 480)	960 (1 800)	960 (1 800)		
Maximum number of butt-jointing track rail ⁽³⁾	2	2	2	2	2		
Maximum length of butt-jointing track rail ⁽³⁾	1 660	1 925	1 880	1 740	1 740		

Notes (1) Not applicable to track rail with stopper pins (supplemental code "/S").

(2) Length up to the value in () can be produced. If needed, please contact IKO.

(3) Not applicable to interchangeable specifications or tapped rail specifications.

(4) Also applicable to tapped rail specification.

Remarks 1. A typical identification number is indicated, but is applied to all models of the same size.

2. Indicate "LWL...B" for the model code of the single track rail regardless of the series and the combination of slide unit models.

3. If not directed, E dimensions for both ends will be the same within the range of standard E dimensions. To change the dimensions, indicate the specified rail mounting hole positions "/E" of special specification. For more information, see page III-30.

Table 3.2 Standard and maximum length of stainless steel track rail (Wide type)

Item	Identification number	LWLF2	LWLF4	MLF 6 ⁽⁴⁾ LWLF6 ⁽⁴⁾	MLF 10 ⁽⁴⁾ LWLF10...B ⁽⁴⁾	MLF 14 ⁽⁴⁾ LWLF14...B ⁽⁴⁾
Standard length L (n)		18 (3) 30 (5) 42 (7) 54 (9)	40 (4) 60 (6) 70 (7) 80 (8) 100 (10)	60 (4) 90 (6) 105 (7) 120 (8) 150 (10)	60 (3) 80 (4) 120 (6) 160 (8) 220 (11) 280 (14)	90 (3) 120 (4) 150 (5) 180 (6) 240 (8) 300 (10)
Pitch of mounting holes F		6	10	15	20	30
E		3	5	7.5	10	15
Standard E or higher dimensions ⁽¹⁾ below		2.5	3.5	4.5	4.5	5.5
Maximum length ⁽²⁾		102	180 (300)	240 (300)	300 (500)	300 (990)
Maximum number of butt-jointing track rail ⁽³⁾		—	—	—	7	8
Maximum length of butt-jointing track rail ⁽³⁾		—	—	—	1 840	1 950
Item	Identification number	MLF 18 ⁽⁴⁾ LWLF18...B ⁽⁴⁾	MLF 24 LWLF24...B	MLF 30 LWLF30...B	MLF 42 LWLF42...B	
Standard length L (n)		90 (3) 120 (4) 150 (5) 180 (6) 240 (8) 300 (10)	120 (3) 160 (4) 240 (6) 320 (8) 400 (10) 480 (12)	160 (4) 240 (6) 320 (8) 440 (11) 560 (14) 680 (17)	160 (4) 240 (6) 320 (8) 440 (11) 560 (14) 680 (17)	
Pitch of mounting holes F		30	40	40	40	
E		15	20	20	20	
Standard E or higher dimensions ⁽¹⁾ below		5.5	6.5	6.5	6.5	
Maximum length ⁽²⁾		690 (1 860)	680 (1 960)	680 (2 000)	680 (2 000)	
Maximum number of butt-jointing track rail ⁽³⁾		3	3	3	3	
Maximum length of butt-jointing track rail ⁽³⁾		1 920	1 840	1 840	1 840	

unit: mm

Notes (1) Not applicable to track rail with stopper pins (supplemental code "/S").

(2) Length up to the value in () can be produced. If needed, please contact IKO.

(3) Not applicable to interchangeable specifications or tapped rail specifications.

(4) Also applicable to tapped rail specification.

Remarks 1. A typical identification number is indicated, but is applied to all models of the same size.

2. Indicate "LWLF...B" for the model code of the single track rail regardless of the series and the combination of slide unit models.

3. If not directed, E dimensions for both ends will be the same within the range of standard E dimensions. To change the dimensions, indicate the specified rail mounting hole positions "/E" of special specification. For more information, see page III-30.

Table 3.3 Standard and maximum length of high carbon steel track rail (Standard type, Wide type)

Item	Identification number	LWL 9...BCS	LWL12...BCS	LWL15...BCS	LWL20...BCS
Standard length L (n)		80 (4) 160 (8) 220 (11) 280 (14) 380 (19) 500 (25) 600 (30)	100 (4) 200 (8) 275 (11) 350 (14) 475 (19) 600 (24) 700 (28)	160 (4) 320 (8) 440 (11) 560 (14) 680 (17) 800 (20) 920 (23)	180 (3) 240 (4) 360 (6) 480 (8) 660 (11) 900 (15) 1 020 (17)
Pitch of mounting holes F		20	25	40	60
E		10	12.5	20	30
Standard E or higher dimensions ⁽¹⁾ below		4.5	5	5.5	8
Maximum length		1 000	1 500	1 520	1 560
Item	Identification number	LWLF18...BCS	LWLF24...BCS	LWLF30...BCS	LWLF42...BCS
Standard length L (n)		90 (3) 180 (6) 240 (8) 300 (10) 420 (14) 510 (17) 600 (20)	120 (3) 240 (6) 320 (8) 400 (10) 600 (15) 720 (18) 800 (20)	160 (4) 320 (8) 440 (11) 560 (14) 680 (17) 800 (20) 920 (23)	160 (4) 320 (8) 440 (11) 560 (14) 680 (17) 800 (20) 920 (23)
Pitch of mounting holes F		30	40	40	40
E		15	20	20	20
Standard E or higher dimensions ⁽¹⁾ below		5.5	6.5	6.5	6.5
Maximum length		1 500	1 520	1 600	1 600

unit: mm

Note (1) Not applicable to track rail with stopper pins (supplemental code "/S").

Remarks 1. A typical identification number is indicated, but is applied to all models of the same size.

2. If not directed, E dimensions for both ends will be the same within the range of standard E dimensions. To change the dimensions, indicate the specified rail mounting hole positions "/E" of special specification. For more information, see page III-30.

8 Preload amount	Clearance	: T ₀	Specify this item for an assembled set or a single slide unit. For details of the preload amount, see Table 4. For applicable preload types, see Table 5.1 and Table 5.2.
	Standard	: No symbol	
	Light preload	: T ₁	

Table 4 Preload amount

Preload type	Item	Preload symbol	Preload amount N	Operational conditions
Clearance		T ₀	0 ⁽¹⁾	• Very light motion
Standard		(No symbol)	0 ⁽²⁾	• Light and precise motion
Light preload		T ₁	0.02 C ₀	• Almost no vibrations • Load is evenly balanced • Light and precise motion

Notes ⁽¹⁾ There is zero or subtle clearance.
⁽²⁾ Indicates zero or minimal amount of preload.
Remark: C₀ indicates the basic static load rating.

Table 5.1 Application of preload (Standard type)

Size	Preload type (preload symbol)		
	Clearance (T ₀)	Standard (No symbol)	Light preload (T ₁)
1	○	—	—
2	○	—	—
3	○	—	—
5	○	○	—
7	○ ⁽¹⁾	○	○ ⁽¹⁾
9	○ ⁽¹⁾	○	○ ⁽¹⁾
12	○ ⁽¹⁾	○	○ ⁽¹⁾
15	○ ⁽¹⁾	○	○ ⁽¹⁾
20	○	○	○
25	○	○	○

Note ⁽¹⁾ Not applicable when /HB is specified.
Remark: The mark indicates that interchangeable specification products are available.

Table 5.2 Application of preload (Wide type)

Size	Preload type (preload symbol)		
	Clearance (T ₀)	Standard (No symbol)	Light preload (T ₁)
2	○	—	—
4	○	—	—
6	○	—	—
10	○	○	—
14	○	○	○
18	○	○	○
24	○	○	○
30	○	○	○
42	○	○	○

Remark: The mark indicates that interchangeable specification products are available.

9 Accuracy class	High	: H	For interchangeable specification products, assemble a slide unit and a track rail of the same accuracy class. Size 1 series have "No symbols." For the details of accuracy class, see Table 6.1 and 6.2.
	Precision	: P	

Table 6.1 Tolerance and allowable values (Series of size 1)

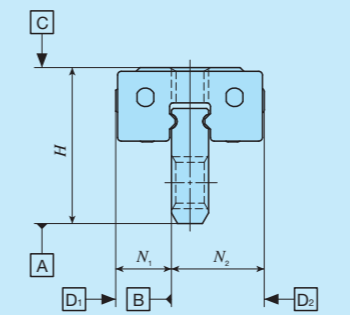

Item	Tolerance
Dim. H tolerance	±0.020
Dim. N ₁ and Dim. N ₂ tolerance	±0.025

unit: mm

Table 6.2 Tolerance and allowance (Series of size 2 or larger excluding LWLF2)

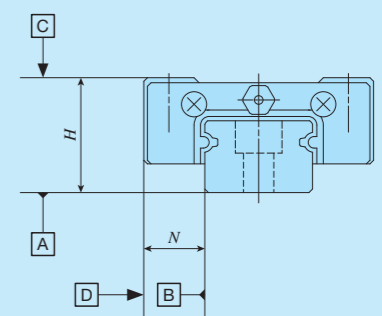

Item	High (H)	Precision (P)
Dim. H tolerance	±0.020	±0.010
Dim. N tolerance	±0.025	±0.015
Dim. variation of H ⁽¹⁾	0.015	0.007
Dim. variation of N ⁽¹⁾	0.020	0.010
Dim. variation of H for multiple assembled sets ⁽²⁾	0.030	0.020
Parallelism in operation of the slide unit C surface to A surface	See Fig. 1	
Parallelism in operation of the slide unit D surface to B surface	See Fig. 1	

unit: mm

Notes ⁽¹⁾ It means the size variation between slide units mounted on the same track rail.
⁽²⁾ Applicable to the interchangeable specification.

Table 6.3 Tolerance and allowance (LWLF 2)

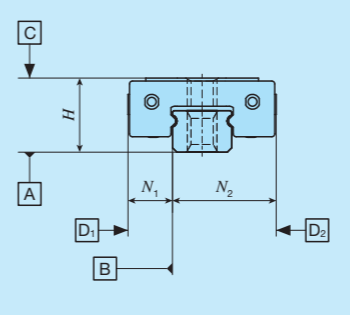

Class (classification symbol)	High (H)	Precision (P)
Dim. H tolerance	±0.020	±0.010
Dim. N ₁ and Dim. N ₂ tolerance	±0.025	±0.015
Dim. variation of H ⁽¹⁾	0.015	0.007
Dim. variation of N ⁽¹⁾	0.020	0.010
Parallelism in operation of the slide unit C surface to A surface	See Fig. 1 (If the track rail length is less than 60mm, the value will be the same as 60mm.)	
Parallelism in operation of the slide unit D surface to B surface	See Fig. 1 (If the track rail length is less than 60mm, the value will be the same as 60mm.)	

unit: mm

Note ⁽¹⁾ It means the size variation between slide units mounted on the same track rail.

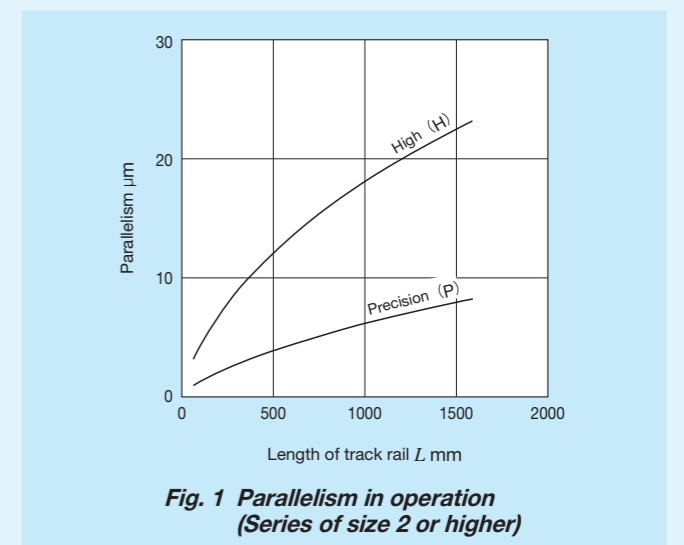
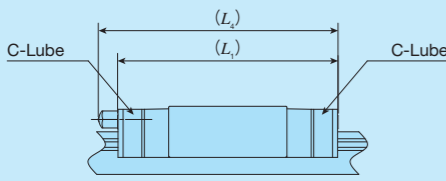

Table 9 Dimension of slide unit with C-Lube plate (Supplemental code /Q)



unit: mm

Identification number	L_1	L_4	Identification number	L_1	L_4
LWLC 5...B	22	—	LWLFC 10...B	26.5	—
LWL 5...B	25	—	LWLF 10...B	30.5	—
LWLC 7...B	27	—	LWLFC 14...B	30.5	—
LWL 7...B	31.5	—	LWLF 14...B	39.5	—
LWLG 7...B	39	—	LWLFG 14...B	50	—
LWLC 9...B	30	—	LWLFC 18...B	34.5	—
LWL 9...B	39	—	LWLF 18...B	46.5	—
LWLG 9...B	49	—	LWLFG 18...B	58.5	—
LWLC 12...B	33	—	LWLFC 24...B	38.5	—
LWL 12...B	42	—	LWLF 24...B	52	—
LWLG 12...B	52	—	LWLFG 24...B	67	—
LWLC 15...B	42	47	LWLFC 30...B	45.5	50
LWL 15...B	52	57	LWLF 30...B	59.5	64
LWLG 15...B	67	72	LWLFG 30...B	78.5	83
LWLC 20...B	48	53	LWLFC 42...B	51.5	56
LWL 20...B	60	65	LWLF 42...B	65	70
LWLG 20...B	78	83	LWLFG 42...B	84.5	89
LWLC 25...B	63.5	74			
LWL 25...B	87.5	98			
LWLG 25...B	107.5	117			

Remarks 1. The dimensions of the slide unit with C-Lube at both ends are indicated.
 2. A typical identification number is indicated, but is applied to all LWL(F) series models of the same size.

Table 10 Load rating / static moment rating of Hybrid C-Lube Linear Way (Supplemental code /HB)

Identification number	C N	C_0 N	T_0 N·m	$T_x^{(1)}$ N·m	$T_y^{(1)}$ N·m
MLC 7.../HB	937	965	3.5	1.6 12.6	1.3 10.6
ML 7.../HB	1 330	1 610	5.9	4.0 23.9	3.3 20.1
MLG 7.../HB	1 690	2 250	8.2	7.5 43.1	6.3 36.2
MLC 9.../HB	1 180	1 260	5.9	2.4 18.2	2.1 15.3
ML 9.../HB	1 810	2 340	10.9	7.7 43.4	6.5 36.4
MLG 9.../HB	2 370	3 420	15.9	15.9 83.6	13.4 70.1
MLL 9.../HB	2 870	4 500	20.9	27.1 134	22.7 112
MLC 12.../HB	2 210	2 030	12.6	4.5 35.5	3.8 29.8
ML 12.../HB	3 330	3 650	22.6	13.1 79.2	11.0 66.4
MLG 12.../HB	4 310	5 270	32.7	26.0 143	21.9 120
MLL 12.../HB	5 820	8 110	50.3	59.3 288	49.8 242
MLC 15.../HB	3 490	3 310	25.5	9.9 71.8	8.3 60.3
ML 15.../HB	4 980	5 520	42.5	25.3 146	21.2 122
MLG 15.../HB	6 620	8 280	63.7	54.3 288	45.5 241
MLL 15.../HB	8 370	11 600	89.2	104 497	86.9 417

Note (1) The upper values of T_x and T_y are for one slide unit and the lower values are for two slide units in close contact.

Table 11 Dimension of track rail with stopper pins (Supplemental code /S)

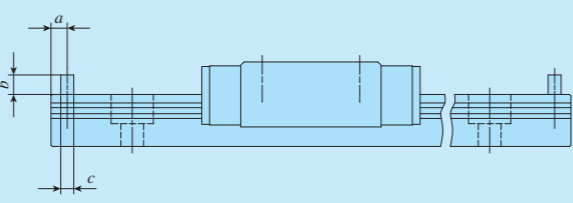

unit: mm

Size	a	b	c
5	—	2	1.6
7	—	2.5	2
9	—	3	
—	10	2	1.6
12	—	3	2
—	14		
15	—	4	
—	18		
20	—	5	
—	24	3	
25	3.5	5	
—	30	4	
—	42	5	

Table 12 H_1 dimension with under seal (Supplemental code /U)

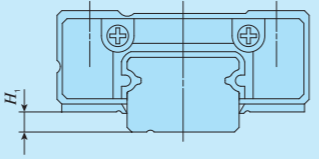

unit: mm

Size	H_1
9	—
12	—
15	—
—	18
20	—
—	24
25	—
—	30
—	42

Note (1) The dimensions are the same as those before mounting of under seal.

Lubrication

Lithium-soap base grease (MULTEMP PS No.2 [KYODO YUSHI CO., LTD.]) is pre-packed in ML(F) and LWL(F) series. Additionally, ML(F) series has C-Lube placed in the recirculation part of balls, so that the interval for reapplying lubricant can be extended and maintenance works such as grease job can be reduced significantly.

ML(F) series and LWL(F) series have grease nipple or oil hole as indicated in Table 14. Since the Size 1, 2, 3, 4 and 6 series do not have an oil hole, apply grease directly to the raceway part of the track rail for re-greasing. Supply nozzles fit to each shapes of grease nipple and dedicated supplying equipment (miniature greasers) fit to oil holes are also available. For order of these parts for lubrication, see Table 13 and Table 14.1 on Page III-23, and Table 15 on page III-24.

Table 13 Oil hole specifications

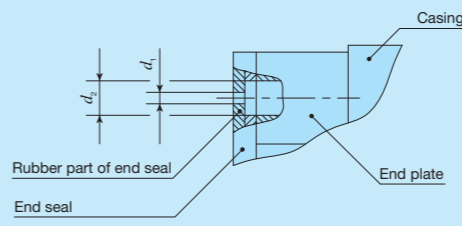

unit: mm

Size	d_1	d_2
5	10	1.1
7	14	1.2
9	18	1.5
12	24	2

Table 14 Parts for lubrication

Size	Grease nipple type (1)	Applicable supply nozzle type	Bolt size of female threads for piping
5, 7, 9, 12	10, 14, 18, 24	Oil hole	Miniature greaser MG10B/MT2
15, 20	30, 42	A-M3	A-5120V A-5240V B-5120V B-5240V
25	—	B-M4	A-8120V B-8120V

Note (1) For grease nipple specification, see Table 14.1 on page III-23.

Remark: Stainless steel grease nipple is also available. If needed, please contact IKO.

Dust Protection

The slide units of ML(F) series and LWL(F) series are equipped with end seals as standard for dust protection. However, if large amount of contaminant or dust are floating, or if large particles of foreign substances such as chips or sand may adhere to the track rail, it is recommended to attach a protective cover to the linear motion mechanism.

No end seal is provided for size 1, 2, 3, 4 or 6 series. For applications in the environment not clean enough, cover the entire unit with a protective case, etc. to prevent harmful foreign substances such as dust and particles from outside to enter.

Precaution for Use

① Mounting surface, reference mounting surface and general mounting structure

When mounting the ML(F) series and LWL(F) series, properly align the reference mounting surfaces B and D (D1 or D2) of the track rail and slide unit with the reference mounting surface of the table and bed and fix them. (See Fig. 2)

Reference mounting surfaces B and D (D1 or D2) and mounting surfaces A and C are precisely ground. By machining the mounting surface of the mating member, such as machine or device, to high accuracy and mounting them properly, stable linear motion with high accuracy is obtained.

The LWL1...Y track rail has the mounting structure in the lateral direction. Two types of mounting structures are available (as shown in Fig. 3.1 and Fig. 3.2).

The reference mounting surfaces of the slide unit LWL1 (Y) and LWLF2 are located at both the left and right sides (D1 and D2). (See Fig. 5.1)

Excluding LWL1 (Y) and LWLF2, the reference mounting surface of the slide unit is on the opposite side of the  mark. (See Fig. 5.2)

The reference mounting surface of the track rail, with the exception of LWL1 (Y), is identified by locating the  mark on the top surface of the track rail. It is the side surface above the mark (in the direction of the arrow). (See Fig. 5.1 and Fig. 5.2)

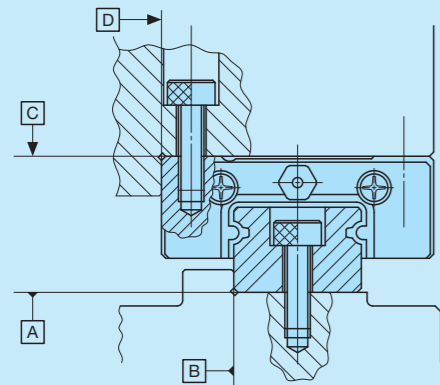

Fig. 2 Reference mounting surface and typical mounting structure

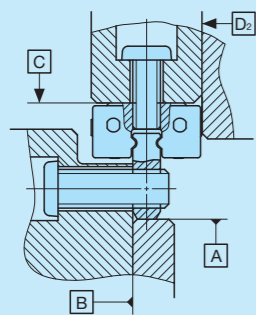

Fig. 3.1 Reference mounting surface of LWL1...Y and typical mounting structure ①

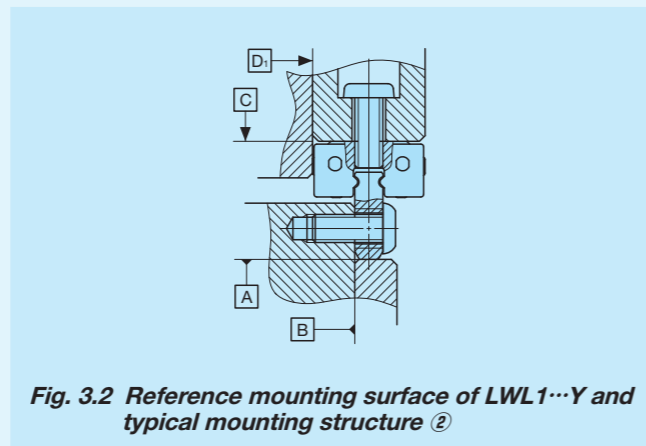

Fig. 3.2 Reference mounting surface of LWL1...Y and typical mounting structure ②

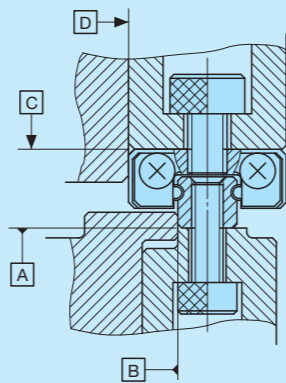

Fig. 4 Reference mounting surface of size 2, 3, 4 and 6 series and typical mounting structure

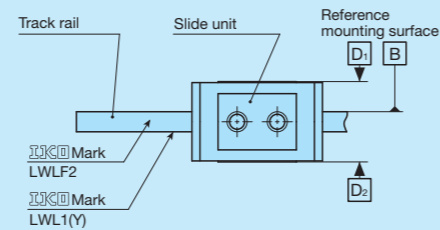

Fig. 5.1 Reference mounting surface of LWL1 (Y) and LWLF2

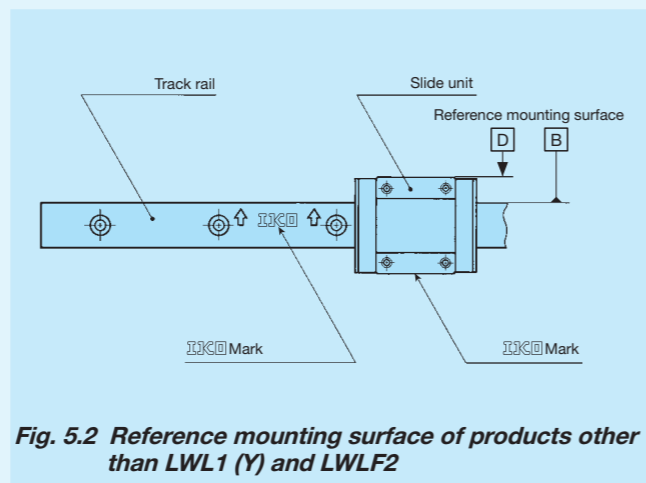

Fig. 5.2 Reference mounting surface of products other than LWL1 (Y) and LWLF2

② Mounting screws for slide unit

To mount a slide unit, tightly fasten the bolt against female thread of slide unit.

The female thread is created through holes of the slide unit for size 1 series, and also through holes for the slide unit and track rail for size 2, 3, 4 and 6 series. When the fixing thread depth of the mounting screw goes too deep, it can interfere with the track rail and impact the running accuracy or product life so that the fixing thread depth should be within the screwing depth specified in the dimension table.

Also prepare the small screws dedicated to precision devices (head diameter 1.8 mm or smaller) for the mounting bolt of slide unit of size 1 and LWLF2.

③ Mounting screws for track rail

In the size 2 and 3 series and tapped rail specifications, track rail mounting bolts are not appended. Prepare mounting bolts whose fixing thread depth is less than H_4 in dimension table.

④ Shoulder height and corner radius of the reference mounting surface

For the opposite corner of the mating reference mounting, it is recommended to have relieved fillet as indicated in Fig. 6. Recommended value for the shoulder height on the mating side is indicated in Table 16.

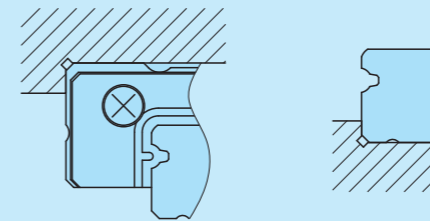

Fig. 6 Corner of the mating reference mounting

⑤ Tightening torque for fixing screw

Typical tightening torque for mounting ML(F) series and LWL(F) series to the steel mating member material is indicated in Table 15. When vibration and shock of the machine or device are large, fluctuating load is large, or moment load is applied, fix it by using the torque 1.2 to 1.5 times larger than the value indicated in the table as necessary. If the mating member material is cast iron or aluminum alloy, reduce the tightening torque depending on the strength characteristics of the mating member material.

Table 15 Tightening torque for fixing screw

Bolt size	Tightening torque N · m	
	Stainless steel-made screw	High carbon steel-made screw
M1 ×0.25	0.04	—
M1.4×0.3	0.10	—
M1.6×0.35	0.15	—
M2 ×0.4	0.31	—
M2.5×0.45	0.62	—
M3 ×0.5	1.1	1.3
M4 ×0.7	2.5	2.9
M5 ×0.8	5.0	5.7
M6 ×1	8.5	—

Remarks 1. The tightening torque is calculated based on strength division 8.8 and property division A2-70.

2. It is recommended that the tightening torque of slide unit mounting holes for series size 1 is to be 70 to 80 % of the values in the table.

Table 16 Shoulder height and corner radius of the reference mounting surface

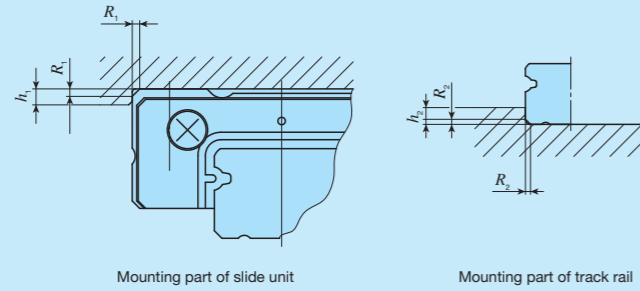

unit: mm

Identification number		Mounting part of slide unit		Mounting part of track rail	
		Shoulder height h_1	Corner radius R_1 (Maximum)	Shoulder height h_2 ⁽¹⁾	Corner radius R_2 (Maximum)
-	LWL 1...Y	1.3	-	2	-
-	LWL 1			-	
-	LWL 2	1	0.1	0.5	0.05
ML 3	LWL 3	1.2	0.15	0.8	0.1
ML 5	LWL 5...B	2	0.3	0.8	0.2
ML 7	LWL 7...B	2.5	0.2	1.2	0.2
ML 9	LWL 9...B	3	0.2	1.5	0.2
-	LWL 9...BCS		0.4		
ML 12	LWL 12...B	4	0.2	2.5	0.2
-	LWL 12...BCS		0.4		
ML 15	LWL 15...B	4.5	0.2	3	0.2
-	LWL 15...BCS		0.4		
ML 20	LWL 20...B	5	0.2	4	0.2
-	LWL 20...BCS		0.4		
ML 25	LWL 25...B	6.5	0.7	4	0.7
-	LWLF 2	1.3	-	-	-
-	LWLF 4	1.5	0.1	0.8	0.1
MLF 6	LWLF 6	2	0.1	0.8	0.1
MLF 10	LWLF 10...B	2	0.3	1.2	0.2
MLF 14	LWLF 14...B	2.5	0.2	1.2	0.2
MLF 18	LWLF 18...B	3	0.2	2.5	0.2
-	LWLF 18...BCS		0.4		
MLF 24	LWLF 24...B	4	0.2	2.5	0.2
-	LWLF 24...BCS		0.4		
MLF 30	LWLF 30...B	4.5	0.2	2.5	0.2
-	LWLF 30...BCS		0.4		
MLF 42	LWLF 42...B	5	0.2	3	0.2
-	LWLF 42...BCS		0.4		

Note ⁽¹⁾ For models with under seals (supplemental code "/U"), it is recommended to use the values 1mm smaller than the values in the table. However for the models of size 9 with under seal, 0.8 mm is recommended.

Remark: A typical identification number is indicated, but is applied to all models of the same size.

Track rail mounting bolts for slide unit and tapped rail specification

For LWL(F) series, track rail mounting bolts for slide unit and tapped rail specification shown in Table 17 and Table 18 are available. If these parts are necessary, please contact IKO. Note that the dimensions are different from the appended track rail mounting bolts.

Table 17 Cross-recessed pan head screw for precision equipment

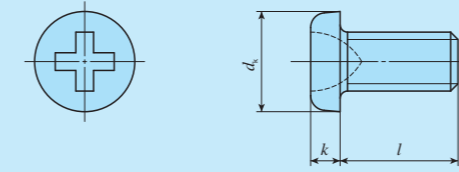

unit: mm

Bolt size (d)	Pitch of screw P	d_k	k	l
M1	0.25	1.8	0.45	3, 4, 5
M1.4 ⁽¹⁾	0.3	2.5	0.8	2.5, 3, 4
M1.6	0.35	2.8	0.85	4, 5, 6
M2 ⁽¹⁾	0.4	3.5	1	3, 4, 5

Note ⁽¹⁾ Based on Camera & Imaging Products Association CIPA AD-003-2020 cross recessed head screw for precision equipment (No. 0 small screw).

Table 18 Hexagon socket head bolt

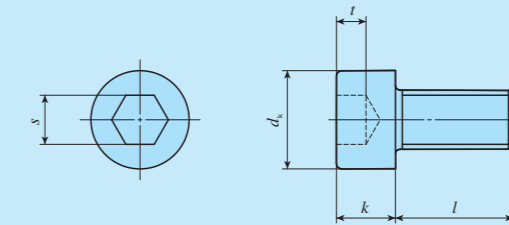

unit: mm

Bolt size (d)	Pitch of screw P	d_k	k	s	t	l
M1.4	0.3	2.6	1.4	1.3	0.6	2.5, 3, 4
M1.6 ⁽¹⁾	0.35	3	1.6	1.5	0.7	4, 5, 6
M2 ⁽¹⁾	0.4	3.8	2	1.5	1	3, 4, 5

Note ⁽¹⁾ Based on hexagon socket head bolts equivalent to JIS B 1176.

IKO C-Lube Linear Way ML

Standard type											
Shape	ML • LWL										
Size	<table border="1"> <tr> <td>1</td><td>2</td><td>3</td><td>5</td><td>7</td> </tr> <tr> <td>9</td><td>12</td><td>15</td><td>20</td><td>25</td> </tr> </table>	1	2	3	5	7	9	12	15	20	25
1	2	3	5	7							
9	12	15	20	25							

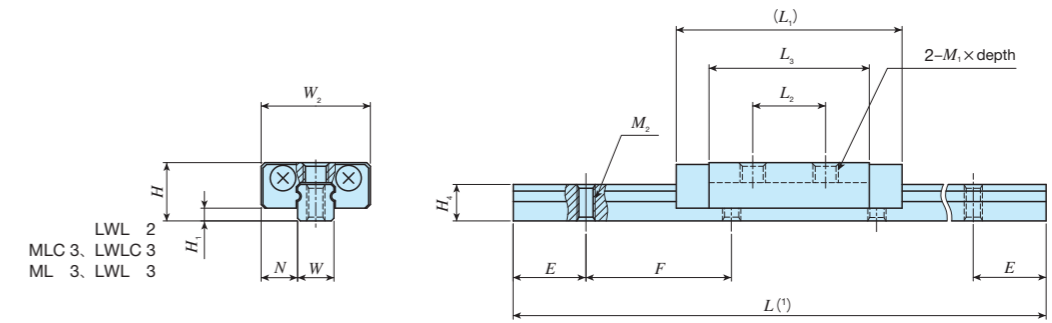
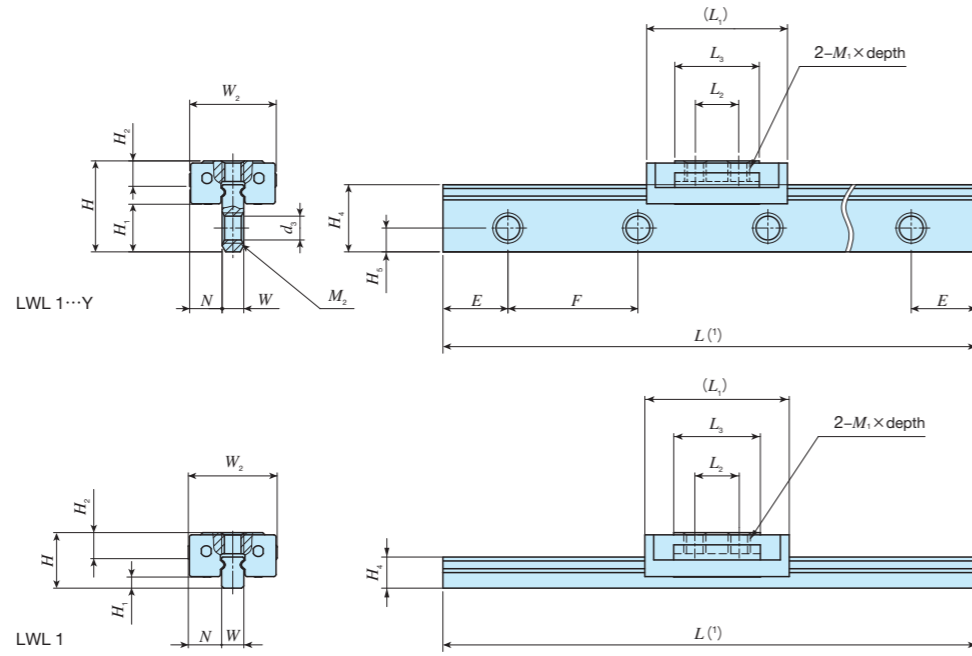

Identification number	Interchangeable	Mass (Ref.) g		Dimensions of assembly mm			Dimensions of slide unit mm							Dimensions of track rail mm						Mounting bolt for track rail (2) mm	Basic dynamic load rating (5) C N	Basic static load rating (5) C0 N	Static moment rating (5) N·m				
		Slide unit	Track rail (per 100 mm)	H	H1	N	W2	L1	L2	L3	M1 × depth	H2	W	H4	H5	M2	d3	E	F				T0	Tx	Ty		
—	LWL 1...Y	—	0.16	2.1	4.2	2.2	1.5	4	6.5	2	3.9	M1 × 0.9	1.2	1	3.1	1.1	M1.4 Through	1.1	3	6	Cross-recessed pan head screw for precision equipment M1 × ℓ or M1.4 × ℓ (3)	66.8	113	0.06	0.07	0.09	
—	LWL 1	—	—	1.0	2.5	0.5	—	—	—	—	—	—	—	1	1.4	—	—	—	—	—	—	—	—	—	—	—	—
—	LWL 2	—	0.9	2.8	3.2	0.7	2	6	12.5	4	8.8	M1.4 × 1.1	—	2	2	—	M1 Through	—	4	8	Cross-recessed pan head screw for precision equipment M1 × ℓ (4)	211	381	0.42	0.54	0.64	
MLC 3	—	—	0.9	5.3	4	1	2.5	8	10.5	3.5	7	M1.6 × 1.3	—	3	2.6	—	M1.6 Through	—	5	10	Cross-recessed pan head screw for precision equipment M1.6 × ℓ (4)	272	406	0.65	0.49	0.58	
LWLC 3	—	1.0	11.5						6.7		251											361	0.58	0.39	3.2		
ML 3	—	1.3	14.5						11	371	632	1.0										1.1	1.3				
LWL 3	—	1.6	15.5						10.7	353	587	0.94										0.98	6.6				

Notes (1) Track rail lengths L are shown in Table 3.1 on page II - 10.
 (2) Track rail mounting bolts are not appended.
 (3) Prepare screws according to mounting structure.
 (4) Choose screws whose dimension allow fixing thread depth into track rail ℓ to be less than H_4 .
 (5) The direction of basic dynamic load rating (C), basic static load rating (C_0), and static moment rating (T_0 , T_x , T_y) are shown in the sketches below.
 The upper values of T_x and T_y are for one slide unit and the lower values are for two slide units in close contact.
 Remarks 1. Metal parts are made of stainless steel.
 2. Do not disassemble a slide unit from the track rail because steel balls are not retained. No end seal is attached.
 3. The specification of small size mounting bolts (M2 and less) are show on page II - 22. If needed, please contact IKO.

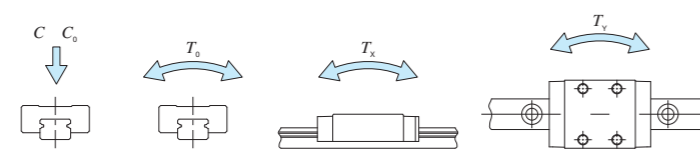

Example of identification number of assembled set

Model code	Dimensions	Part code	Model code	Preload symbol	Classification symbol	Supplemental code
LWL	2	C2 R80	—	T0	P	/D
①	②	③	④	⑤	⑥	⑦

① Model	③ Size	⑥ Preload amount	⑧ Special specification
ML LWL LWL...Y	1, 2, 3	To Clearance	BS, D, E, I, W, Y
② Length of slide unit	④ Number of slide unit (2)	⑦ Accuracy class	
C No symbol		No symbol H P	Ordinary High Precision
⑤ Length of track rail (80 mm)			

IKO C-Lube Linear Way ML

Standard type											
Shape	ML • LWL										
Size	<table border="1"> <tr> <td>1</td> <td>2</td> <td>3</td> <td>5</td> <td>7</td> </tr> <tr> <td>9</td> <td>12</td> <td>15</td> <td>20</td> <td>25</td> </tr> </table>	1	2	3	5	7	9	12	15	20	25
1	2	3	5	7							
9	12	15	20	25							

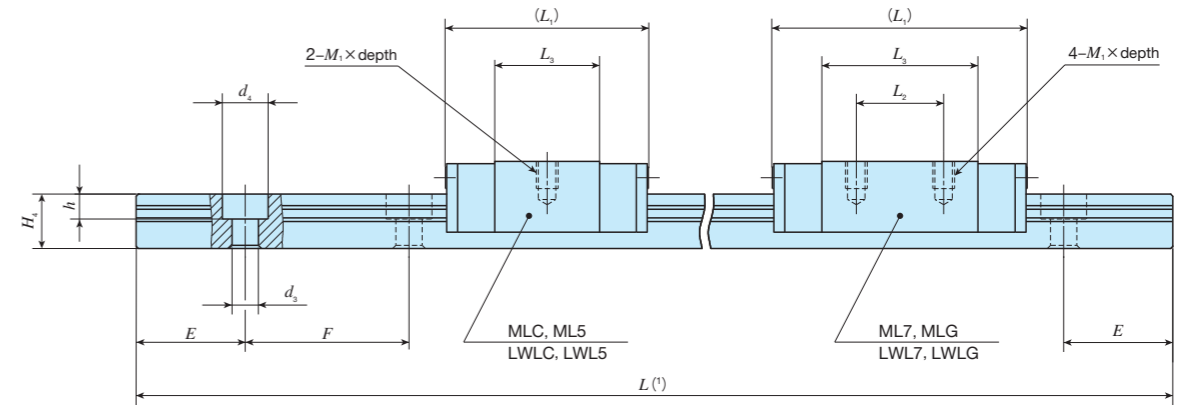
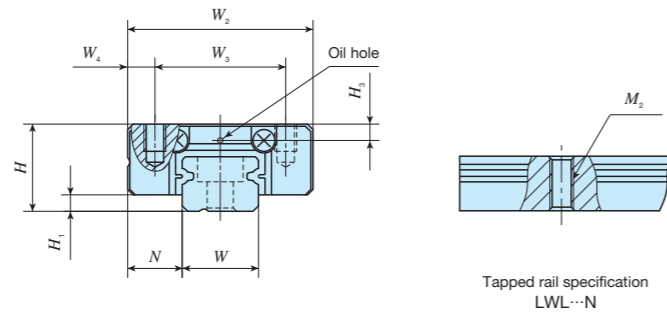

Identification number	Interchangeable	Mass (Ref.) g		Dimensions of assembly mm			Dimensions of slide unit mm							Dimensions of track rail mm						Appended mounting bolt for track rail (2) mm	Basic dynamic load rating (4) C N	Basic static load rating (4) C0 N	Static moment rating (4) N·m						
		Slide unit	Track rail (per 100 mm)	H	H1	N	W2	W3	W4	L1	L2	L3	M1 x depth	H3	W	H4	M2	d3	d4				h	E	F	T0	Tx	Ty	
MLC 5	LWLC 5...B	○	3.4	12	6	1	3.5	12	8	2	16	-	9.6	M2 x 1.5	1.2	5	3.7	-	2.4	3.6	0.8	7.5	15	Cross-recessed pan head screw for precision equipment M2 x 6	562	841	2.2	1.4 8.5	1.2 7.2
MLC 5...N*	LWLC 5...N*	-	13																										
ML 5	LWL 5...B	○	4.3	12																									
ML 5...N*	LWL 5...N*	-	4.4	13																									
MLC 7	LWLC 7...B	○	6.7	22	8	1.5	5	17	12	2.5	19	-	9.6	M2 x 2.5	1.5	7	5	-	2.4	4.2	2.3	7.5	15	Hexagon socket head bolt M2 x 6	937	1 140	4.1	1.8 14.9	1.5 12.5
MLC 7...N*	LWLC 7...N*	-	6.7	24																									
ML 7	LWL 7...B	○	9.1	22																									
ML 7...N*	LWL 7...N*	-	10	24																									
MLG 7	LWLG 7...B	○	13	22	31	12	21.6	-	-	-	31	12	21.6	-	-	7	5	-	2.4	4.2	2.3	7.5	15	Hexagon socket head bolt M2 x 6	1 330	1 890	6.9	4.7 28.2	3.9 23.6
MLG 7...N*	LWLG 7...N*	-	14	24																									
MLG 7	LWLG 7...B	○	13	22																									
MLG 7...N*	LWLG 7...N*	-	14	24																									

Notes (1) Track rail lengths L are shown in Table 3.1 on page II - 10.
 (2) The appended mounting bolts are hexagon socket head bolts equivalent to JIS B 1176 or CIPA AD-003-2020 cross recessed head screw for precision equipment (No. 0 small screw).
 (3) Choose screws whose dimension allow fixing thread depth into track rail ℓ to be less than H_4 .
 (4) The direction of basic dynamic load rating (C), basic static load rating (C_0), and static moment rating (T_0 , T_x , T_y) are shown in the sketches below.
 The upper values of T_x and T_y are for one slide unit and the lower values are for two slide units in close contact.
 If hybrid C-Lube Linear Way specification (supplemental code "/HB") is selected in MLC7, ML7, and MLG7, see Table 10 on page II - 17.

Remarks 1. The specification of oil hole is shown in Table 13 on page II - 18.
 2. The identification numbers with * are our semi-standard items.

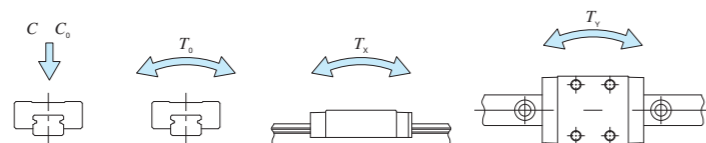

Example of identification number of assembled set

Model code	Dimensions	Part code	Model code	Preload symbol	Classification symbol	Interchangeable code	Supplemental code
ML	C	7	C2	R120	T1	P	/D
①	②	③	④	⑤	⑥	⑦	⑧
① Model	② Length of slide unit	③ Size	④ Number of slide unit (2)	⑤ Length of track rail (120 mm)	⑥ Preload amount	⑦ Accuracy class	⑧ Interchangeable
ML LWL...B LWL...N	C Short No symbol Standard G Long	5, 7	2	120	T0 Clearance No symbol Standard T1 Light preload	H High P Precision	No symbol Non-interchangeable specification S1 S1 specification S2 S2 specification
							⑨ Special specification
							A, BS, D, E, HB, I, LR MN, N, Q, RE, S, W, Y

IKO C-Lube Linear Way ML

Standard type											
Shape	ML • LWL										
Size	<table border="1"> <tr> <td>1</td><td>2</td><td>3</td><td>5</td><td>7</td> </tr> <tr> <td>9</td><td>12</td><td>15</td><td>20</td><td>25</td> </tr> </table>	1	2	3	5	7	9	12	15	20	25
1	2	3	5	7							
9	12	15	20	25							

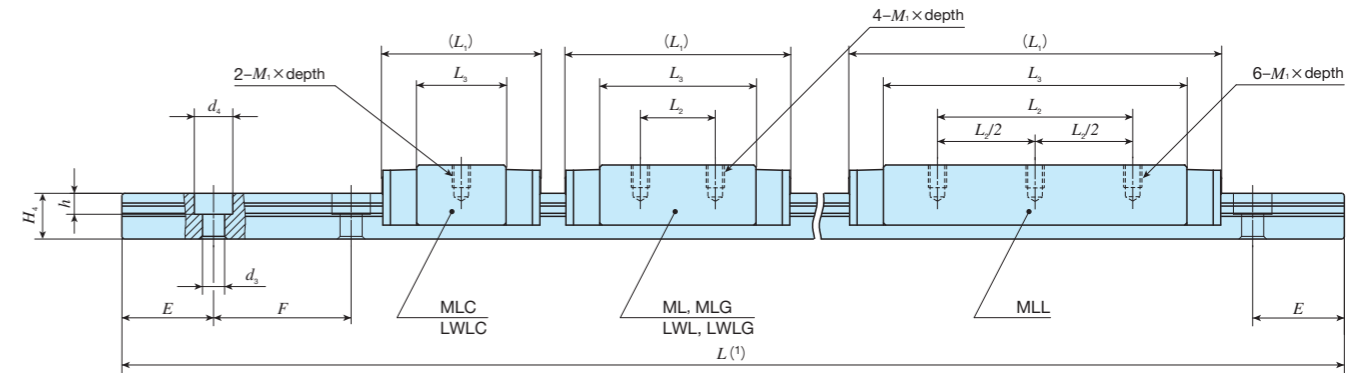
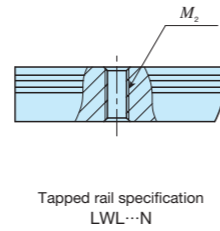
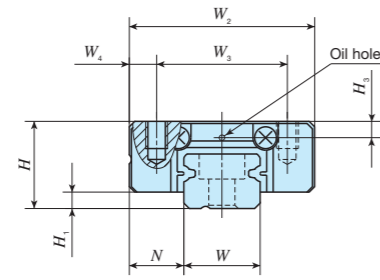

Identification number	ML series	LWL series (No C-Lube)	Interchangeable	Mass (Ref.) g		Dimensions of assembly mm			Dimensions of slide unit mm					Dimensions of track rail mm					Appended mounting bolt for track rail mm Bolt size × ℓ	Basic dynamic load rating ⁽⁴⁾ C N	Basic static load rating ⁽⁴⁾ C ₀ N	Static moment rating ⁽⁴⁾																																																														
				Slide unit	Track rail (per 100 mm)	H	H ₁	N	W ₂	W ₃	W ₄	L ₁	L ₂	L ₃	M ₁ × depth	H ₃	W	H ₄				M ₂	d ₃	d ₄	h	E	F	T ₀ N · m	T _x N · m	T _y N · m																																																						
MLC 9	9	LWLC 9...B	○	11	35	10	2	5.5	20	15	2.5	M3×3	2.2	9	6	M4 Through	3.5	6	3.5	10	20	M3×8	1 180	1 480	6.9	2.9 21.4	2.4 18.0																																																									
MLC 9...N*	9...N*	LWLC 9...N*	—	37	21.5																							—	11.9	—	—	—	—	—	—	—	—	—	—	—	—	—	—	—	—	—	—	—																																				
ML 9	9	LWL 9...B	○	18	35																							30	10	20.8	M3×3	2.2	9	6	M4 Through	3.5	6	3.5	10	20	M3×8	1 810	2 760	12.8	9.1 51.1	7.6 42.9																																						
—	—	LWL 9...BCS	○	19	37																																										—	—	—	—	—	—	—	—	—	—	—	—	—	—	—	—	—	—	—	—																		
ML 9...N*	9...N*	LWL 9...N*	—	18	37																																										—	—	—	—	—	—	—	—	—	—	—	—	—	—	—	—	—	—	—	—	—																	
MLG 9	9	LWLG 9...B	○	26	35																																										40.5	15	30.9	M3×3	2.2	9	6	M4 Through	3.5	6	3.5	10	20	M3×8	2 370	4 030	18.7	18.7 98.3	15.7 82.5																			
MLG 9...N*	9...N*	LWLG 9...N*	—	26	37																																																													—	—	—	—	—	—	—	—	—	—	—	—	—	—	—	—	—	—	—
MLL 9	9	—	○	35	37																																																													—	—	—	—	—	—	—	—	—	—	—	—	—	—	—	—	—	—	—
MLL 9...N*	9...N*	—	—	34	37																							50	26	40.4	—	—	—	—	—	—	—	—	—	—	—	—	—	—	—	—	—																																					
MLC 12	12	LWLC 12...B	○	22	35																							65	13	3	7.5	27	20	3.5	M3×3.5	2.7	12	8	—	3.5	6.5	4.5	12.5	25	M3×8	2 210	2 380	14.8	5.3 41.7	4.5 35.0																																		
ML 12	12	LWL 12...B	○	34	37	25	—	13	—	—	—	—	—	—	—	—	—	—	—	—	—	—	—	—	—																																																											
—	—	LWL 12...BCS	○	35	37	34	15	21.6	—	—	—	—	—	—	—	—	—	—	—	—	—	—	—	—	—	—																																																										
MLG 12	12	LWLG 12...B	○	48	37	44	20	32	—	—	—	—	—	—	—	—	—	—	—	—	—	—	—	—	—	—																																																										
MLL 12	12	—	○	51	37	59.5	30	47.3	—	—	—	—	—	—	—	—	—	—	—	—	—	—	—	—	—	—																																																										
MLL 12...N*	12...N*	—	—	70	37	—	—	—	—	—	—	—	—	—	—	—	—	—	—	—	—	—	—	—	—	—																																																										

Notes (1) Track rail lengths L are shown in Table 3.1 on page II - 10 and Table 3.3 on page II - 12.
 (2) The appended track rail mounting bolts are hexagon socket head bolts equivalent to JIS B 1176. For stainless steel model, stainless steel bolts are appended.
 (3) Choose screws whose dimension allow fixing thread depth into track rail ℓ to be less than H_4 .
 (4) The direction of basic dynamic load rating (C), basic static load rating (C_0), and static moment rating (T_0 , T_x , T_y) are shown in the sketches below.
 The upper values of T_x and T_y are for one slide unit and the lower values are for two slide units in close contact.
 If hybrid C-Lube Linear Way specification (supplemental code "/HB") is selected in ML series, see Table 10 on page II - 17.

Remarks 1. The specification of oil hole is shown in Table 13 on page II - 18.
 2. The identification numbers with * are our semi-standard items.

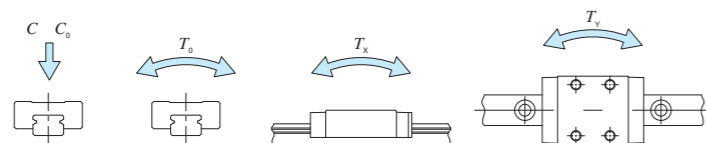

Example of identification number of assembled set

Model code	Dimensions	Part code	Model code	Material code	Preload symbol	Classification symbol	Interchangeable code	Supplemental code	
ML	G	9	C2	R160	T1	P	/D		
1	2	3	4	5	6	7	8	9	
1 Model	2 Length of slide unit	3 Size	4 Number of slide unit (2)	5 Length of track rail (160 mm)	6 Material type	7 Preload amount	8 Accuracy class	9 Interchangeable	10 Special specification
ML LWL...B LWL...N	C No symbol G L	9, 12	2	CS High carbon steel made	T ₀ Clearance No symbol Standard T ₁ Light preload	H High P Precision	A, BS, D, E, HB, I, LR, MN N, Q, RE, S, U, W, Y	No symbol S1 S2	No symbol S1 specification S2 specification

IKO C-Lube Linear Way ML

Standard type					
Shape	ML • LWL				
Size	1	2	3	5	7
	9	12	15	20	25

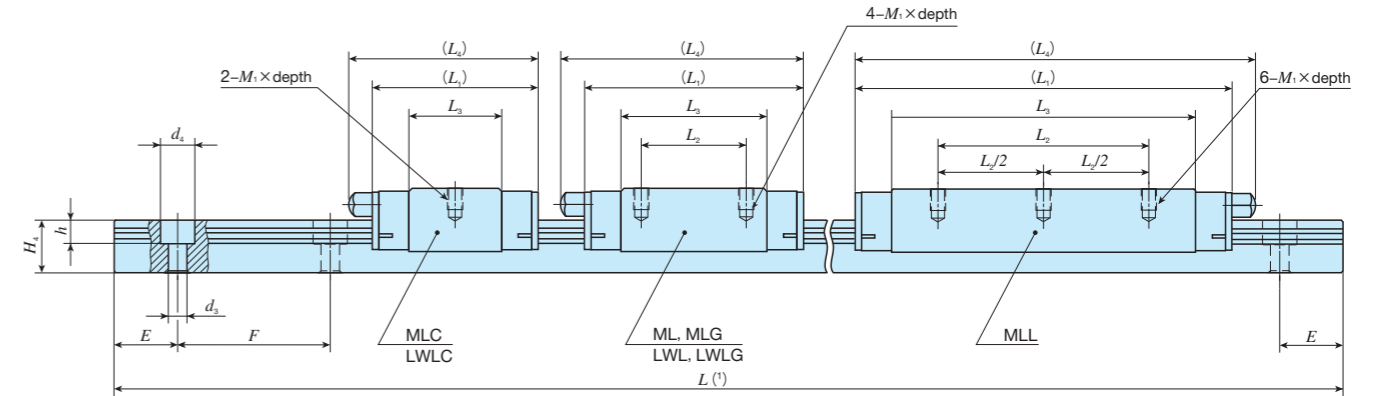
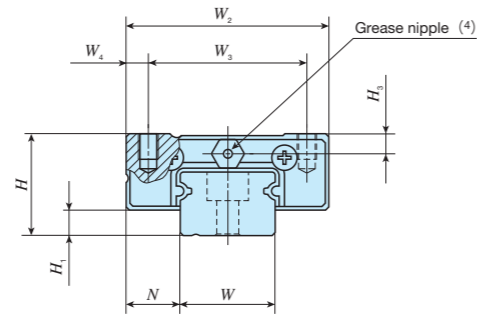

Identification number	Interchangeable	Mass (Ref.) g		Dimensions of assembly mm							Dimensions of slide unit mm					Dimensions of track rail mm						Appended mounting bolt for track rail (2) mm	Basic dynamic load rating (3) C N	Basic static load rating (3) C0 N	Static moment rating (3) N·m			
		Slide unit	Track rail (per 100 mm)	H	H1	N	W2	W3	W4	L1	L2	L3	L4	M1 × depth	H3	W	H4	d3	d4	h	E				F	Bolt size × ℓ	T0	Tx
MLC 15	○	43	107	16	4	8.5	32	25	3.5	32	—	17.8	37	M3×4	3.1	15	10	3.5	6.5	4.5	20	40	M3×10	3 490	3 890	30.0	11.7 84.5	9.8 70.9
LWLC 15...B	○	42								42	20	27.8	47															
ML 15	○	63								42	20	27.8	47															
LWL 15...B	○	64								42	20	27.8	47															
LWL 15...BCS	○	64								42	20	27.8	47															
MLG 15	○	93								57	25	42.8	62															
LWLG 15...B	○	95	57	25	42.7	62																						
MLL 15	○	122	72	40	57.7	76																						
MLC 20	○	89	156	20	5	10	40	30	5	38	—	22.3	43	M4×6	4.2	20	11	6	9.5	5.5	30	60	M5×14	4 580	5 300	54.0	19.4 134	16.3 112
LWLC 20...B	○	89								50	25	34.6	55															
ML 20	○	130								50	25	34.6	55															
LWL 20...B	○	133								50	25	34.6	55															
LWL 20...BCS	○	133								50	25	34.6	55															
MLG 20	○	189								68	30	52.3	73															
LWLG 20...B	○	196	68	30	52.3	73																						
MLC 25	○	189	243	25	5	12.5	48	35	6.5	54.5	—	31.9	64	M6×7	5	23	15	7	11.0	9.0	30	60	M6×16	9 120	10 600	128	57.4 376	48.1 316
LWLC 25...B	○	190								78	35	55.7	88															
ML 25	○	305								78	35	55.7	88															
LWL 25...B	○	310								78	35	55.7	88															
MLG 25	○	405	98	40	75.5	108																						
LWLG 25...B	○	413	98	40	75.5	108																						

- Notes (1) Track rail lengths L are shown in Table 3.1 on page II-10 and Table 3.3 on page II-12.
 (2) The appended track rail mounting bolts are hexagon socket head bolts equivalent to JIS B 1176. For stainless steel model, stainless steel bolts are appended.
 (3) The direction of basic dynamic load rating (C), basic static load rating (C_0), and static moment rating (T_0 , T_x , T_y) are shown in the sketches below. The upper values of T_x and T_y are for one slide unit and the lower values are for two slide units in close contact. If hybrid C-Lube Linear Way specification (supplemental code "/HB") is selected in MLC15, ML15, MLG15, and MLL15, see Table 10 on page II-17.
 (4) The shapes of grease nipple vary by size. The specifications are shown in Table 14 on page II-18.

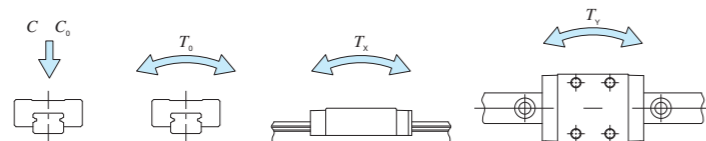

Example of identification number of assembled set

Model code	Dimensions	Part code	Model code	Material code	Preload symbol	Classification symbol	Interchangeable code	Supplemental code
ML	G	15	C2	R320	T1	P	/D	
1	2	3	4	5	6	7	8	9

① Model ML LWL...B Standard type	③ Size 15, 20, 25	⑦ Preload amount T0 Clearance No symbol Standard T1 Light preload	⑨ Interchangeable No symbol Non-interchangeable specification S1 S1 specification S2 S2 specification
② Length of slide unit C Short No symbol Standard G Long L Extra high rigidity long	④ Number of slide unit (2)	⑧ Accuracy class H High P Precision	⑩ Special specification A, BS, D, E, HB, I, LR, MN N, O, RE, S, U, W, Y
⑤ Length of track rail (320 mm)	⑥ Material type No symbol Stainless steel made CS High carbon steel made		

Wide type											
Shape	MLF • LWLF										
Size	<table border="1"> <tr> <td>2</td> <td>4</td> <td>6</td> <td>10</td> <td>14</td> </tr> <tr> <td>18</td> <td>24</td> <td>30</td> <td>42</td> <td></td> </tr> </table>	2	4	6	10	14	18	24	30	42	
2	4	6	10	14							
18	24	30	42								

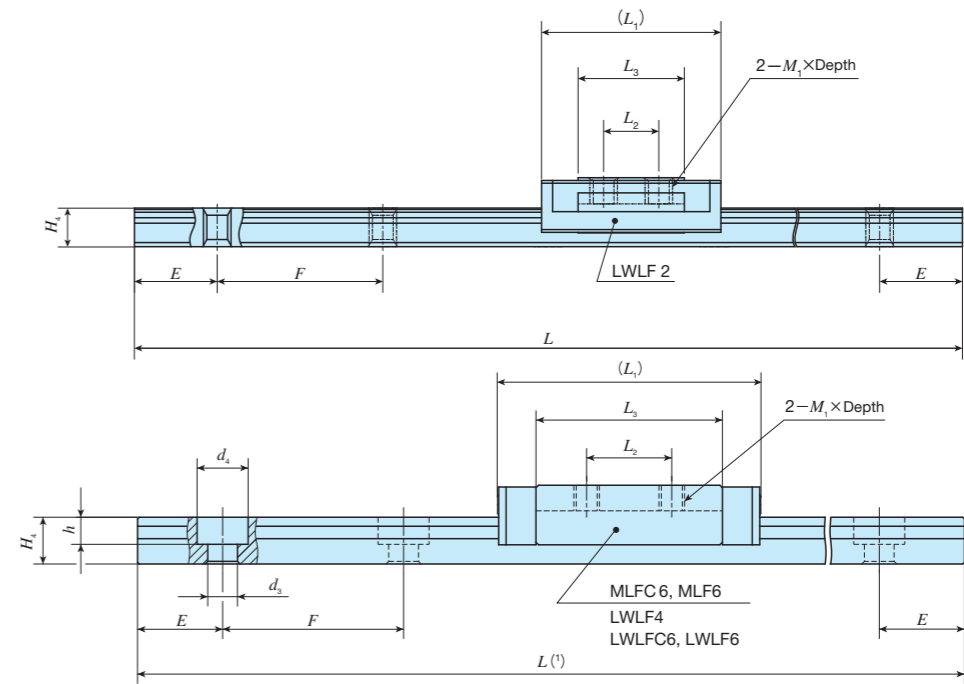
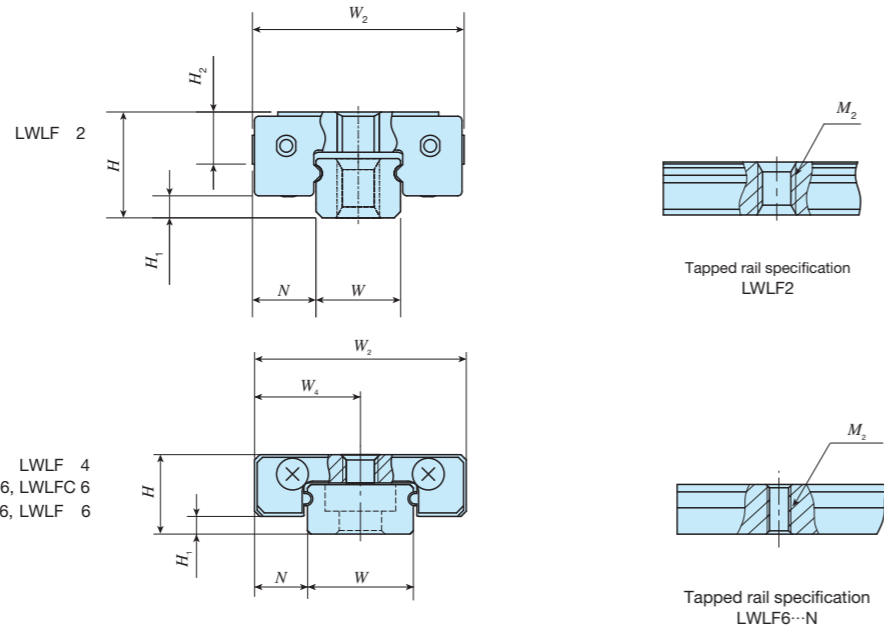

Identification number	Interchangeable	Mass (Ref.) g		Dimensions of assembly mm			Dimensions of slide unit mm							Dimensions of track rail mm						Appended mounting bolt for track rail mm	Basic dynamic load rating ⁽⁴⁾ C N	Basic static load rating ⁽⁴⁾ C ₀ N	Static moment rating ⁽⁴⁾											
		Slide unit	Track rail (per 100 mm)	H	H ₁	N	W ₂	W ₃	W ₄	L ₁	L ₂	L ₃	M ₁ × depth	H ₂	H ₃	W	H ₄	M ₂	d ₃				d ₄	h	E	F	Bolt size × ℓ	T ₀ N·m	T _x N·m	T _y N·m				
—	LWLF 2 ⁽²⁾	—	0.21	2	2.5	0.5	1.5	5	—	—	6.5	2	3.9	M1 × 0.9	1.2	—	2	1.4	M1 Through	—	—	—	3	6	M1 × ℓ ⁽³⁾ (Not appended)	66.8	113	0.12	0.07 0.47	0.09 0.56				
—	LWLF 4 ⁽²⁾	—	2.1	6.8	4	1	3	10	—	5	17	6.5	11.9	M2 × 1.3	—	—	4	2.6	—	1.8	2.8	0.75	5	10	Cross-recessed pan head screw for precision equipment M1.6 × 5	390	677	1.4	1.3 7.1	1.5 8.4				
MLFC 6 ⁽²⁾	LWLFC 6 ⁽²⁾	—	2.1	13	4.5	1	3	12	—	6	15	4.5	9.8	M2 × 1.6	—	—	6	2.8	—	2.4	4	1.5	7.5	15	Cross-recessed pan head screw for precision equipment M2 × 4	334	542	1.7	0.84 5.1	1.0 6.1				
MLFC 6..N ^{(2)*}	LWLFC 6..N ^{(2)*}	—	2.1	12																					M3 Through						—	—	—	M3 × ℓ ⁽³⁾ (Not appended)
MLF 6 ⁽²⁾	LWLF 6 ⁽²⁾	—	3.1	13																					—	—	—	—	Cross-recessed pan head screw for precision equipment M2 × 4	443	813	2.5	1.8 9.9	2.2 11.8
MLF 6..N ^{(2)*}	LWLF 6..N ^{(2)*}	—	3.1	12																					M3 Through	—	—	—	M3 × ℓ ⁽³⁾ (Not appended)					

Notes ⁽¹⁾ Track rail lengths L are shown in Table 3.2 on page II-11.

⁽²⁾ Steel balls are not retained. No end seal is attached.

⁽³⁾ Choose screws whose dimension allow fixing thread depth into track rail ℓ to be less than H_4 .

⁽⁴⁾ The direction of basic dynamic load rating (C), basic static load rating (C_0), and static moment rating (T_0 , T_x , T_y) are shown in the sketches below.

The upper values of T_x and T_y are for one slide unit and the lower values are for two slide units in close contact.

Remarks 1. The identification numbers with * are our semi-standard items.

2. There is no oil hole on the slide unit.

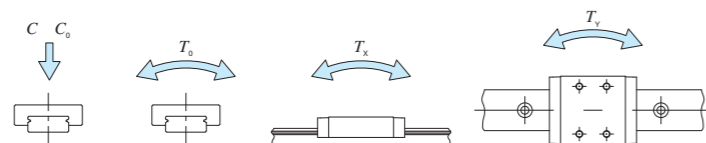

1N=0.102kgf

Example of identification number of assembled set

Model code	Dimensions	Part code	Model code	Preload symbol	Classification symbol	Interchangeable code	Supplemental code
MLF	C	6	C2	R120	T ₀	P	/D
①	②	③	④	⑤	⑥	⑦	⑧

① Model	Wide type
MLF	
LWLF	
LWLF..N	

③ Size	2, 4, 6, 10
④ Number of slide unit	(2)

⑥ Preload amount	Clearance
T ₀	Standard
No symbol	

⑧ Interchangeable	Non-interchangeable specification
No symbol	S1 specification
S1	S2 specification
S2	

② Length of slide unit	Standard
C	
No symbol	

⑤ Length of track rail (120 mm)	
---------------------------------	--

⑦ Accuracy class	Precision
H	
P	

⑨ Special specification	A, BS, D, E, I, MN, N, Q
	RE, S, W, Y

IKO C-Lube Linear Way ML

Wide type											
Shape	MLF • LWLF										
Size	<table border="1"> <tr> <td>2</td> <td>4</td> <td>6</td> <td>10</td> <td>14</td> </tr> <tr> <td>18</td> <td>24</td> <td>30</td> <td>42</td> <td></td> </tr> </table>	2	4	6	10	14	18	24	30	42	
2	4	6	10	14							
18	24	30	42								

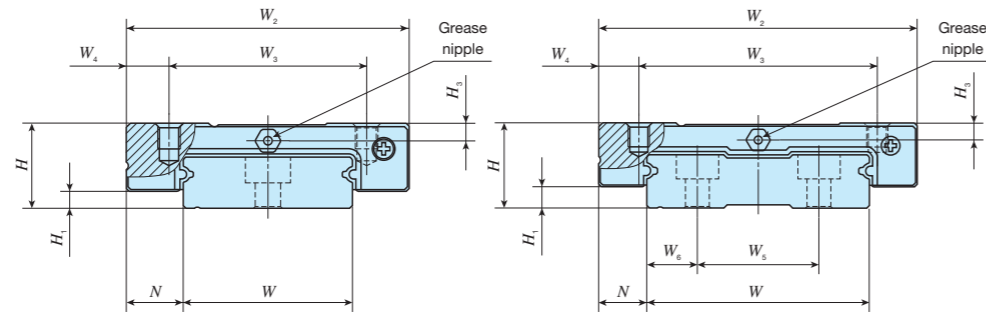

MLFC 42, LWLFC 42
MLF 42, LWLF 42
MLFG 42, LWLFG 42

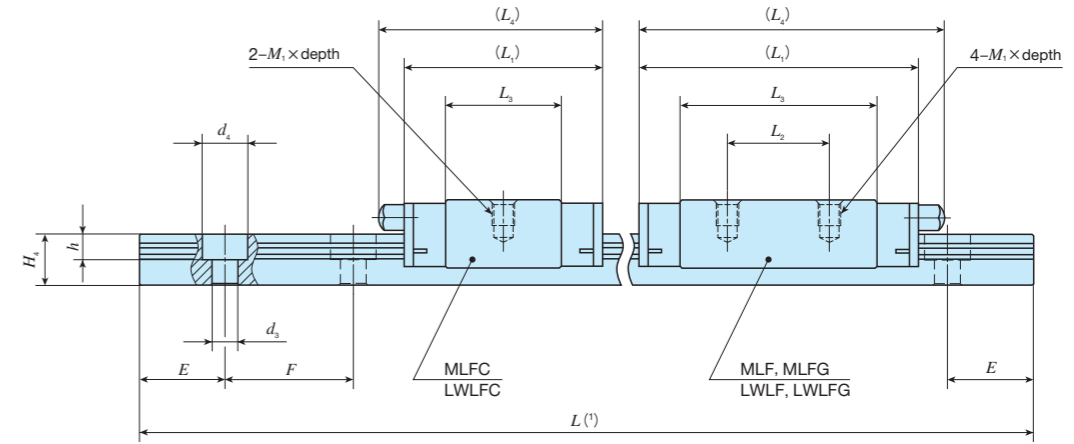

Identification number	Interchangeable	Mass (Ref.) g		Dimensions of assembly mm			Dimensions of slide unit mm							Dimensions of track rail mm							Appended mounting bolt for track rail mm Bolt size × ℓ	Basic dynamic load rating ⁽²⁾ C N	Basic static load rating ⁽²⁾ C ₀ N	Static moment rating ⁽³⁾							
		Slide unit	Track rail (per 100 mm)	H	H ₁	N	W ₂	W ₃	W ₄	L ₁	L ₂	L ₃	L ₄	M ₁ × depth	H ₃	W	H ₄	W ₅	W ₆	d ₃				d ₄	h	E	F	T ₀ N · m	T _x N · m	T _y N · m	
MLFC 30	LWLFC 30...B	○	70	198	15	3	10	50	35	7.5	35.5	—	20.5	40	M4×4.5	3.1	30	9	—	—	4.5	8	4.5	20	40	M4×12	3 890	4 540	69.1	15.4	13.0
MLF 30	LWLF 30...B	○	111								49.5	18	34.8	54															128	48.7	40.8
—	LWLF 30...BCS	○	112								68.5	35	53.8	73															187	100	84.3
MLFG 30	LWLFG 30...B	○	167								—	—	—	—															128	256	215
—	LWLFG 30...B	○	170								—	—	—	—															187	508	426
MLFC 42	LWLFC 42...B	○	95	294	16	4	9	60	45	7.5	41.5	—	25.7	46	M4×4.5	3.2	42	10	23	9.5	4.5	8	4.5	20	40	M4×12	5 440	6 810	144	30.8	25.8
—	LWLF 42...B	○	138								55	20	39.4	60															128	24.8	20.8
—	LWLF 42...BCS	○	140								74.5	35	58.7	79															209	61.3	51.4
MLFG 42	LWLFG 42...B	○	200								—	—	—	—															321	140	117
—	LWLFG 42...B	○	204								—	—	—	—															305	644	541

Notes (1) Track rail lengths L are shown in Table 3.2 on page II - 11 and Table 3.3 on page II - 12.
 (2) The appended track rail mounting bolts are hexagon socket head bolts equivalent to JIS B 1176. For stainless steel model, stainless steel bolts are appended.
 (3) The direction of basic dynamic load rating (C), basic static load rating (C_0), and static moment rating (T_0 , T_x , T_y) are shown in the sketches below.
 The upper values of T_x and T_y are for one slide unit and the lower values are for two slide units in close contact.
 Remark: The specifications of grease nipple are shown in Table 14 on page II - 18.

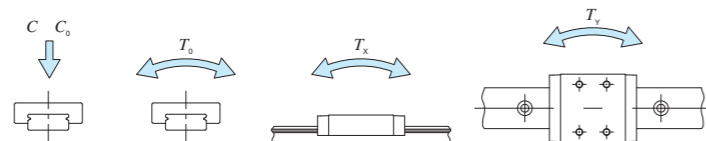

Example of identification number of assembled set

Model code	Dimensions	Part code	Model code	Material code	Preload symbol	Classification symbol	Interchangeable code	Supplemental code
MLF	G	42	C2	R320	T1	P	/D	
①	②	③	④	⑤	⑥	⑦	⑧	⑨

① Model	③ Size	⑦ Preload amount	⑨ Interchangeable
MLF LWLF...B	Wide type	T ₀ Clearance No symbol Standard T ₁ Light preload	No symbol Non-interchangeable specification S1 S1 specification S2 S2 specification
② Length of slide unit	⑤ Length of track rail (320 mm)	⑧ Accuracy class	⑩ Special specification
C Short No symbol Standard G Long	⑥ Material type	H High P Precision	A, BS, D, E, I, LR, MN N, Q, RE, S, U, W, Y
	CS Stainless steel made High carbon steel made		