

TSLH...M
CTLH...M

TSLH...M · CTLH...M

TSLH...M

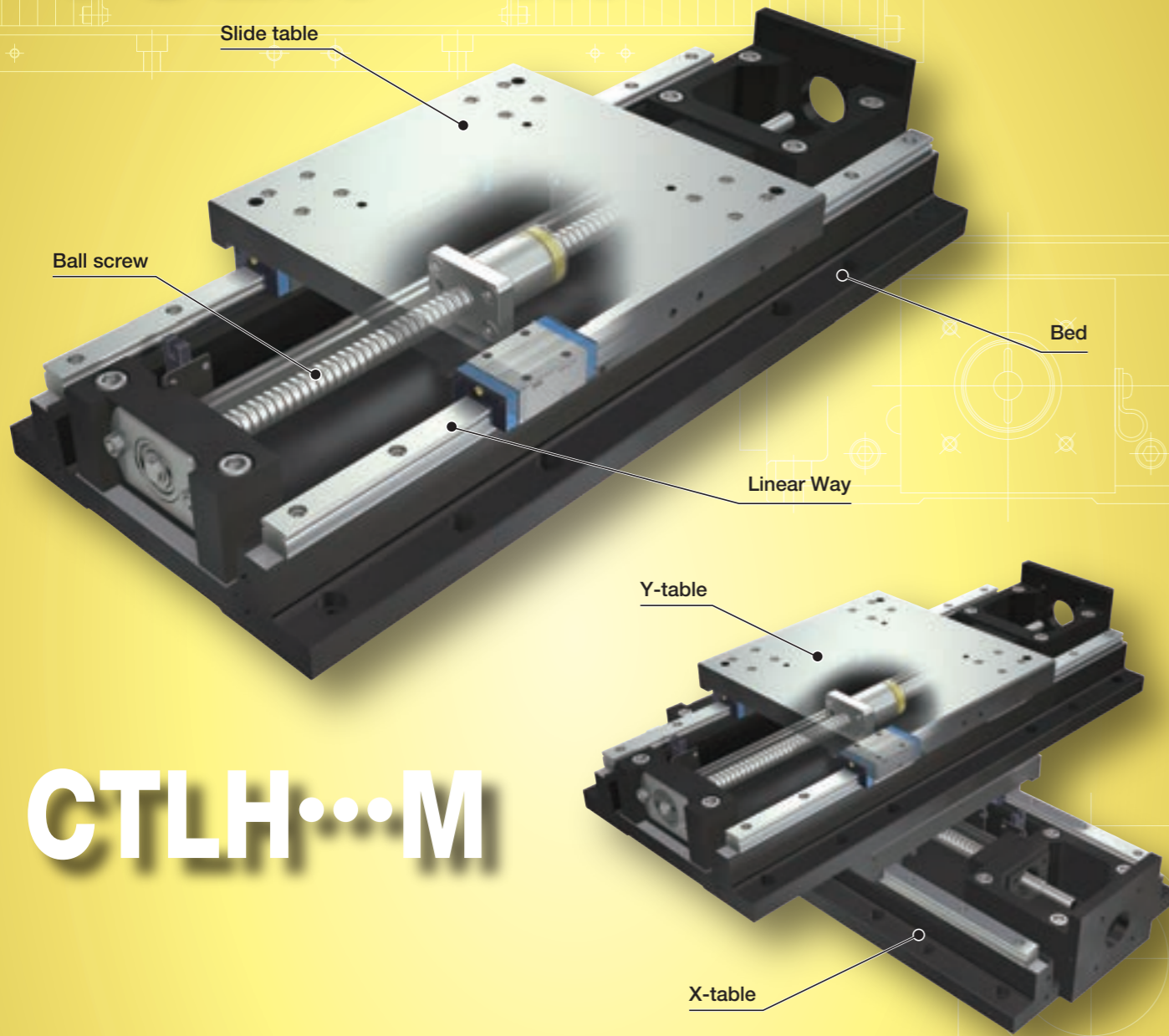
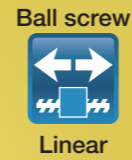

CTLH...M

Major product specifications

Driving method	Precision ball screw
Linear motion rolling guide	Linear Way (ball type)
Built-in lubrication part	Lubrication part "C-Lube" is built-in
Material of table and bed	Cast iron
Sensor	Provided as standard

Accuracy

unit: mm

Positioning repeatability	±0.002
Positioning accuracy	0.010~0.035
Lost motion	-
Parallelism in table motion A	0.010~0.035
Parallelism in table motion B	-
Attitude accuracy	-
Straightness	0.005~0.025
Backlash	0.001

Points

1 High precision, high rigidity positioning table

High precision, high rigidity positioning table configured with high rigidity and vibration damping performance cast iron slide tables and beds.

2 High running accuracy and positioning accuracy

High running accuracy and high accuracy positioning are realized by incorporating 2 sets of Linear Way in parallel on cast iron slide tables and beds finished by accurate ground and combining with precision ball screws.

3 High rigidity and large carrying mass

The structure with large carrying mass, and resistant to moment and complex load since 2 sets of Linear Way are optimally positioned on the high rigidity bed.

Variation

Shape	Model and size	Table width (mm)	Stroke length (mm)											
			100	150	200	250	300	400	500	600	800	1000		
	TSLH120M	120	☆	☆	☆	☆	☆	-	-	-	-	-	-	-
	TSLH220M	220	-	☆	☆	☆	☆	☆	(☆)	(☆)	-	-	-	-
	TSLH320M	320	-	-	-	-	☆	☆	☆	(☆)	(☆)	(☆)	(☆)	(☆)
	TSLH420M	420	-	-	-	-	-	-	☆	☆	☆	(☆)	(☆)	(☆)

Identification Number

Example of an Identification Number
(Single-axis specification)

1 2 1 3 4 5 6 7
TSLH 120 M - 300 / AT301 10 J R

1 Model Page II-126

2 Size Page II-126

3 Stroke length Page II-126

4 Designation of motor attachment Page II-126

5 Ball screw lead Page II-126

6 Designation of bellow Page II-126

7 Surface treatment Page II-126

Identification Number and Specification

- 1 Model TSLH...M: Precision Positioning Table LH (single-axis specification)
- 2 Size Size indicates table width.
Select a size from the list of Table 1.
- 3 Stroke length Select a stroke length from the list of Table 1.
As for a table with bellows, available stroke length is somewhat shorter, so please see the dimension table.

Table 1 Sizes, table width dimensions, and stroke lengths unit: mm

Model and size	Table width	Stroke length
TSLH120M	120	100, 150, 200, 250, 300
TSLH220M	220	150, 200, 250, 300, 400 (500, 600)
TSLH320M	320	300, 400, 500 (600, 800, 1 000)
TSLH420M	420	500, 600, 800 (1 000)

Remark: If the stroke length shown in () is needed, please contact IKO.

- 4 Designation of motor attachment As for a motor attachment, select it from the list of Table 3.
 - Motor should be prepared by customer.
 - Please specify motor attachment applicable to motor for use.
 - A coupling shown in Table 4 is mounted on the main body before shipment. However, the final position adjustment should be made by customer since it is only temporarily fixed.
 - When specifying an AC servomotor attachment, an origin sensor is not provided.
- 5 Ball screw lead 5: Lead 5mm
10: Lead 10mm
- 6 Designation of bellow No symbol: Without bellows
J : With bellows
As for a table with bellows, available stroke length is somewhat shorter, so please see the dimension table.
- 7 Surface treatment No symbol: Black chrome surface treatment
R : Black chrome surface treatment 1
L : Black chrome surface treatment 2
Black chrome surface treatment: This treatment is performed on main parts excluding Linear Way, ball screw, and ball bearing.
Black chrome surface treatment 1: In addition to the above black chrome surface treatment, this treatment is performed even on the surface of Linear Way.
Black chrome surface treatment 2: In addition to the above black chrome surface treatment 1, this treatment is performed even on the surface of ball screw.
The black chrome surface treatment improves the corrosion resistance by forming black permeable film on the surface.
For the upper and lower surfaces of the main body and the reference surfaces of respective parts, surface treatment is excluded.

Identification Number

Example of an Identification Number
(Two-axis specification)

1 2 1 3 4 5 6 7 8 9
CTLH 120 M - 30 20 / AT301 10 J R C



Identification Number and Specification

- 1 **Model** CTLH...M: Precision Positioning Table LH (two-axis specification)
- 2 **Size** Size indicates table width.
Select a size from the list of Table 2.
Tables of different sizes can also be combined.
- 3 **X-axis stroke length** Select a stroke length from the list of Table 2.
- 4 **Y-axis stroke length** Stroke lengths of respective axes are displayed in cm. Please note that allowable lengths for X- and Y-axes vary.
As for a table with bellows, available stroke length is somewhat shorter, so please see the dimension table.

Table 2 Sizes, table width dimensions, and stroke lengths

unit: mm

Model and size	Table width	Stroke length	
		X-axis	Y-axis
CTLH120M	120	100	100
		200	100
		200	200
		300	200
		300	300
CTLH220M	220	200	200
		300	200
		300	300
		400	300
		400	400
CTLH320M	320	300	300
		400	300
		400	400
		500	400
		500	500

- 5 **Designation of motor attachment** As for a motor attachment, select it from the list of Table 3.
 - Motor should be prepared by customer.
 - Please specify motor attachment applicable to motor for use.
 - A coupling shown in Table 4 is mounted on the main body before shipment. However, the final position adjustment should be made by customer since it is only temporarily fixed.
 - When specifying an AC servomotor attachment, an origin sensor is not provided.
- 6 **Ball screw lead** 5: Lead 5mm
10: Lead 10mm
- 7 **Designation of bellows** No symbol: Without bellows
J : With bellows
As for a table with bellows, available stroke length is somewhat shorter, so please see the dimension table.
- 8 **Surface treatment** No symbol: Black chrome surface treatment
R : Black chrome surface treatment 1
L : Black chrome surface treatment 2
Black chrome surface treatment: This treatment is performed on main parts excluding Linear Way, ball screw, and ball bearing.
Black chrome surface treatment 1: In addition to the above black chrome surface treatment, this treatment is performed even on the surface of Linear Way.
Black chrome surface treatment 2: In addition to the above black chrome surface treatment 1, this treatment is performed even on the surface of ball screw.
The black chrome surface treatment improves the corrosion resistance by forming black permeable film on the surface.
For the upper and lower surfaces of the main body and the reference surfaces of respective parts, surface treatment is excluded.
- 9 **Designation of combination direction** No symbol: Standard configuration
C : Reverse configuration
Standard configuration: A direction under the condition where X-axis motor side is placed at the front and Y-axis motor side is placed on the right side respectively.
Reverse configuration: A direction under the condition where X-axis motor side is placed at the front and Y-axis motor side is placed on the left side respectively.

Table 3 Application of motor attachment

Type	Models of motor to be used				Flange size mm	Motor attachment				
	Manufacturer	Series	Model	Rated output W		TSLH120M CTLH120M	TSLH220M CTLH220M	TSLH320M CTLH320M	TSLH420M	
AC servo motor	YASKAWA ELECTRIC CORPORATION	Σ-7	SGM7J-01A	100	□40	AT301	—	—	—	
			SGM7A-01A			AT301	—	—	—	
			SGM7J-02A	200	□60	AT302	AT303	—	—	
			SGM7A-02A			AT302	AT303	—	—	
			SGM7J-04A	400	□60	—	AT303	AT304	—	
			SGM7A-04A			—	AT303	AT304	—	
		SGM7J-08A	750	□80	—	—	AT305	AT306		
		SGM7A-08A			—	—	AT305	AT306		
		Mitsubishi Electric Corporation	J4/J5	HG-MR13	100	□40	AT301	—	—	—
				HG-KR13/HK-KT13W			AT301	—	—	—
				HG-MR23	200	□60	AT302	AT303	—	—
				HG-KR23/HK-KT23W			AT302	AT303	—	—
	HG-MR43			400	□60	—	AT303	AT304	—	
	HG-KR43/HK-KT43W					—	AT303	AT304	—	
	HG-MR73	750	□80	—	—	AT305	AT306			
	HG-KR73/HK-KT7M3W			—	—	AT305	AT306			
	Panasonic Corporation	MINAS A6	MSMF01	100	□38	AT307	—	—	—	
			MSMF02	200	□60	AT308	AT309	AT311	—	
			MSMF04	400		—	AT310	AT312	—	
			MSMF08	750	□80	—	—	AT313	AT314	
			Hitachi Industrial Equipment Systems Co., Ltd	AD	ADMA-01L	100	□40	AT301	—	—
	ADMA-02L	200			□60	AT302	AT303	—	—	
	ADMA-04L	400				—	AT303	AT304	—	
	ADMA-08L	750			□75	—	—	AT305	AT306	
Stepper motor	ORIENTAL MOTOR Co., Ltd.	α step	ARM66	□60	AT315	—	—	—		
			ARM69		AT315	—	—	—		
			ARM98	□85	—	AT317	AT318	—		
			ARM911		—	AT317	AT318	—		
		RKS CRK	CRK56 ⁽¹⁾	□60	AT316	—	—	—		
			RKS59	□85	—	AT317	AT318	—		

Note (1) Applicable to the outer diameter φ8 of motor output shaft.
Remark: For detailed motor specifications, please see respective motor manufacturer's catalog.

Table 4 Coupling models

Motor attachment	Coupling models	Manufacturer	Coupling inertia J_c $\times 10^{-5} \text{kg} \cdot \text{m}^2$
AT301	UA-25C- 8× 8	Sakai Manufacturing Co., Ltd	0.290
AT302	UA-30C- 8×14	Sakai Manufacturing Co., Ltd	0.603
AT303	UA-35C-12×14	Sakai Manufacturing Co., Ltd	1.34
AT304	UA-35C-14×15	Sakai Manufacturing Co., Ltd	1.34
AT305	UA-40C-15×19	Sakai Manufacturing Co., Ltd	2.61
AT306	UA-40C-15×19	Sakai Manufacturing Co., Ltd	2.61
AT307	UA-25C- 8× 8	Sakai Manufacturing Co., Ltd	0.290
AT308	UA-30C- 8×11	Sakai Manufacturing Co., Ltd	0.603
AT309	UA-35C-11×12	Sakai Manufacturing Co., Ltd	1.34
AT310	UA-35C-12×14	Sakai Manufacturing Co., Ltd	1.34
AT311	UA-35C-11×15	Sakai Manufacturing Co., Ltd	1.34
AT312	UA-35C-14×15	Sakai Manufacturing Co., Ltd	1.34
AT313	UA-40C-15×19	Sakai Manufacturing Co., Ltd	2.61
AT314	UA-40C-15×19	Sakai Manufacturing Co., Ltd	2.61
AT315	MSTS-25C- 8×10	Nabeya Bi-tech Kaisha	0.71
AT316	MSTS-25C- 8× 8	Nabeya Bi-tech Kaisha	0.71
AT317	MSTS-32C-12×14	Nabeya Bi-tech Kaisha	2.7
AT318	MSTS-40C-14×15	Nabeya Bi-tech Kaisha	9.0

Remark: For detailed coupling specifications, please see respective manufacturer's catalog.

Table 5 Accuracy

Model and size	Stroke length		Positioning repeatability	Positioning accuracy	Parallelism in table motion A	Straightness	Squareness of XY motion	Backlash
	X-axis	Y-axis						
Single-axis specification	TSLH120M	100	±0.002	0.010	0.010	0.005	—	0.001
		150						
		200						
		250						
	TSLH220M	300	±0.002	0.015	0.015	0.005	—	0.001
		150						
		200						
		250						
	TSLH320M	300	±0.002	0.020	0.015	0.005	—	0.001
		400						
		500						
		600						
TSLH420M	500	±0.002	0.025	0.025	0.015	—	0.001	
	600							
	800							
	800							
Two-axis specification	CTLH120M	100	±0.002	0.015	0.015	0.005	0.005	0.001
		200						
		200						
		200						
	CTLH220M	200	±0.002	0.020	0.025	0.010	0.010	0.001
		300						
		300						
		300						
	CTLH320M	300	±0.002	0.020	0.020	0.005	0.010	0.001
		400						
		400						
		400						

Table 6 Maximum speed

Motor type	Model and size		Maximum speed mm/s	
	Single-axis specification	Two-axis specification	Lead 5mm	Lead 10mm
AC servo motor	TSLH120M TSLH220M	CTLH120M CTLH220M	250	500
	TSLH320M TSLH420M	CTLH320M	224	448
Stepper motor	TSLH120M TSLH220M TSLH320M	CTLH120M CTLH220M CTLH320M	150	300

Remark: To measure the practical maximum speed, it is required to consider operation patterns based on the motor to be used and load conditions.

Table 7 Maximum carrying mass

Model and size	Ball screw lead mm	Carrying mass center of gravity mm Length L Height H	Maximum carrying mass kg							
			Horizontal direction				Vertical direction			
			0	100	200	300	0	100	200	300
TSLH120M	5	0	135	82	48	34	28	28	28	28
		100	135	82	48	34	28	28	28	26
		200	135	81	48	34	28	28	28	23
	10	0	135	79	47	34	28	28	24	20
		100	135	63	36	26	28	28	28	23
		200	135	61	36	25	28	28	28	20
TSLH220M	5	0	218	218	141	103	30	30	30	30
		100	218	218	140	103	30	30	30	30
		200	218	218	140	103	30	30	30	30
	10	0	218	214	139	102	30	30	30	30
		100	187	170	108	79	29	29	29	29
		200	187	167	107	78	29	29	29	29
TSLH320M	5	0	536	536	498	378	27	27	27	27
		100	536	536	496	377	27	27	27	27
		200	536	536	494	376	27	27	27	27
	10	0	536	536	491	375	27	27	27	27
		100	254	254	254	254	25	25	25	25
		200	254	254	254	254	25	25	25	25
TSLH420M	5	0	519	519	519	437	10	10	10	10
		100	519	519	519	437	10	10	10	10
		200	519	519	519	436	10	10	10	10
	10	0	519	519	519	435	10	10	10	10
		100	237	237	237	237	8	8	8	8
		200	237	237	237	237	8	8	8	8

Remark1. The maximum carrying mass is adjusted by the mass when the rating life of the linear motion rolling guide, ball screws, or bearings is 18,000 hours during continuous operation at a number of revolutions of the motor of 3000min⁻¹ and an acceleration/deceleration time of 0.2s. The mass calculated is based upon the basic static load rating of the linear motion rolling guide.
2. Please also check the maximum load mass on page III-19.

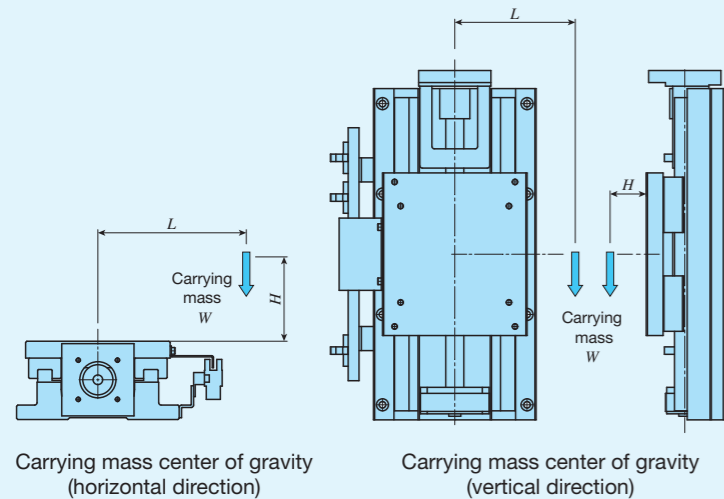
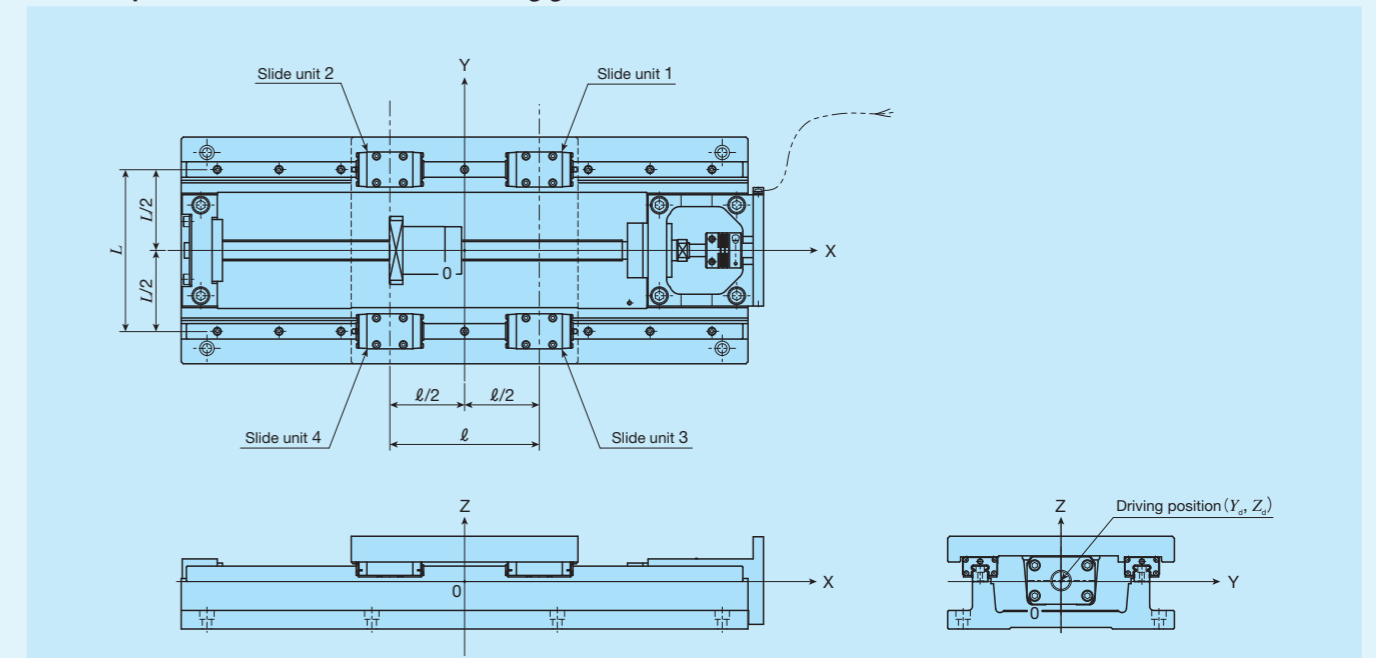

Table 8 Specifications of linear motion rolling guide



Model and size	Basic dynamic load rating ⁽¹⁾ C N	Basic static load rating ⁽¹⁾ C ₀ N	Arrangement			
			L mm	ℓ mm	Y _d mm	Z _d mm
TSLH120M	6 260	8 330	88	82	0	2
TSLH220M	11 600	13 400	157	145	0	1
TSLH320M	25 200	28 800	240	210	0	6
TSLH420M	30 800	38 300	300	290	0	0

Note ⁽¹⁾ Represent the value per slide unit.

Table 9.1 Specifications of ball screw 1

Model and size	Lead mm	Shaft dia. mm	Axial clearance mm	Basic dynamic load rating C N	Basic static load rating C ₀ N
TSLH120M	5	15	0	7 070	12 800
	10			7 070	12 800
TSLH220M	5	20	0	8 230	17 510
	10			10 900	21 700
TSLH320M	5	25	0	16 700	43 500
TSLH420M	10			15 800	32 700

Specifications

Table 9.2 Specifications of ball screw 2

unit: mm

Model and size	Stroke length	Shaft dia.	Overall length
TSLH120M	100	15	256
	150		306
	200		356
	250		406
	300		456
TSLH220M	150	20	370
	200		420
	250		470
	300		520
TSLH320M	300	25	616
	400		716
	500		816
TSLH420M	500	25	916
	600		1 016
	800		1 216

Table 10 Table inertia and starting torque

Model and size	Stroke length mm		Table inertia J_T $\times 10^{-5} \text{kg} \cdot \text{m}^2$		Starting torque T_s $\text{N} \cdot \text{m}$		
	X-axis	Y-axis	Lead 5mm	Lead 10mm	Lead 5mm	Lead 10mm	
Single-axis specification	TSLH120M	100	1.2	1.7	0.07		
		150	1.4	1.9			
		200	1.5	2.1			
		250	1.7	2.3			
		300	1.9	2.5			
	TSLH220M	150	5.1	6.9	0.12		
		200	5.7	7.5			
		250	6.3	8.1			
		300	7.0	8.7			
	TSLH320M	300	20	26	0.20		
400		23	29				
500		26	32				
TSLH420M	500	30	39	0.22			
	600	33	42				
	800	39	48				
Two-axis specification	CTLH120M	100	100	1.8	4.2	0.08	
		200	100	2.2	4.5		
		200	200	2.3	5.1		
		300	200	2.7	5.5		
		300	300	2.8	6.0		
	CTLH220M	200	200	7.8	16	0.12	
		300	200	9.1	17		
		300	300	9.3	18		
		400	300	11	19		
	CTLH320M	300	300	27	51	0.22	0.25
		400	300	30	54		
		400	400	30	57		
		500	400	33	60		
		500	500	34	62		

Remark: As for tables of two-axis specification, the figures represent values in X-axis. For values in Y-axis, see the figures for single-axis specification.

Mounting

For the processing accuracy of the Precision Positioning Table mounting surface and the tightening torque of the fixing screws, see page III-36.

Sensor Specification

Table 11.1 Sensor timing chart (without bellows)

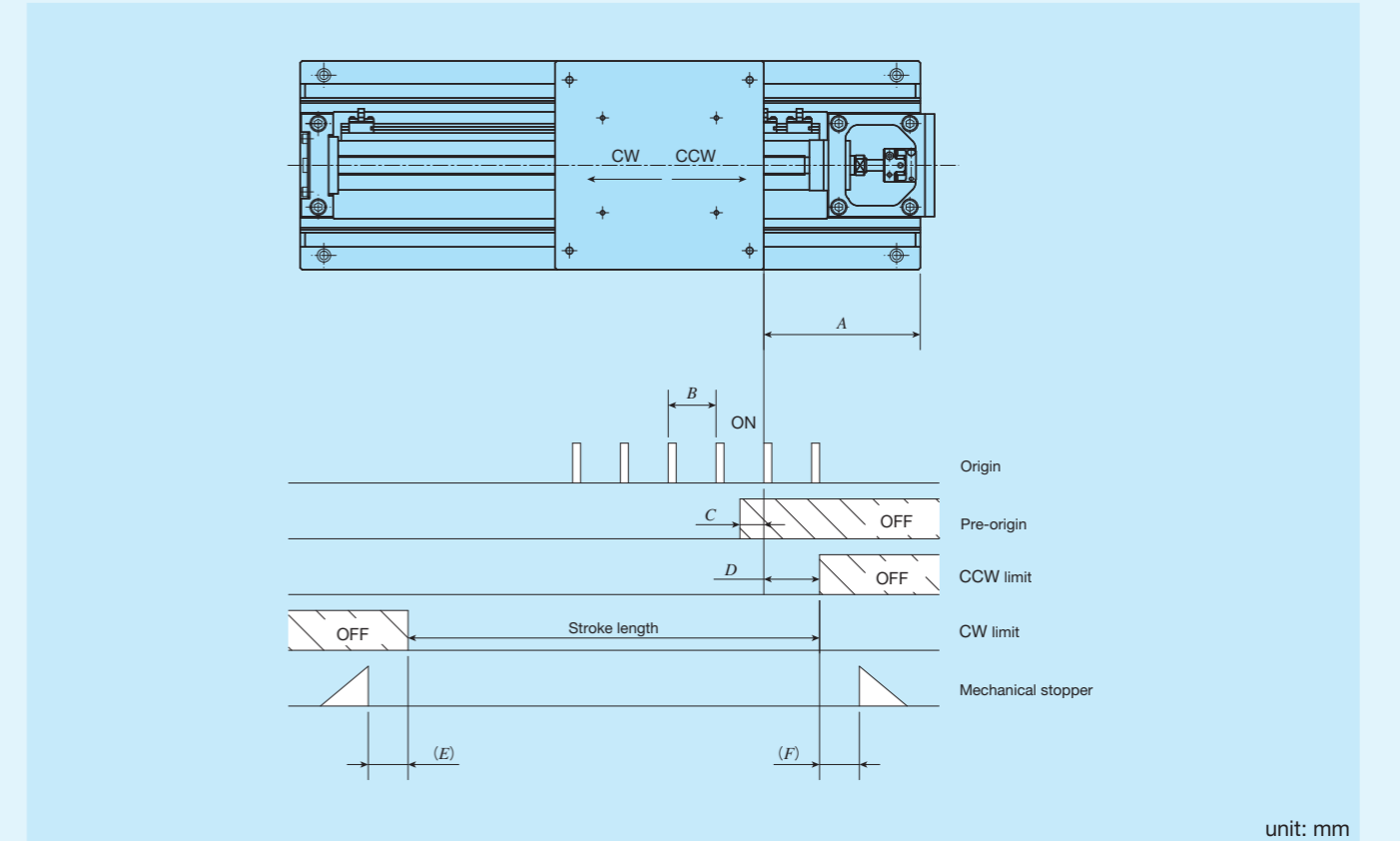

unit: mm

Model and size	Ball screw lead	A	B	C	D	E	F
TSLH120M	5	50	5	3	30	5.5	4.5
	10		10	7			
TSLH220M	5	45	5	3	30	14	10
	10		10	7			
TSLH320M	5	45	5	3	30	20	15
	10		10	7			
TSLH420M	5	45	5	3	30	18	15
	10		10	7			

Remarks 1. For detailed specifications of respective sensors, please see the section of sensor specification in General Explanation.
2. The values of respective axes in tables of two-axis specification are the same as those of tables of single-axis specification.

Table 11.2 Sensor timing chart (with bellows)

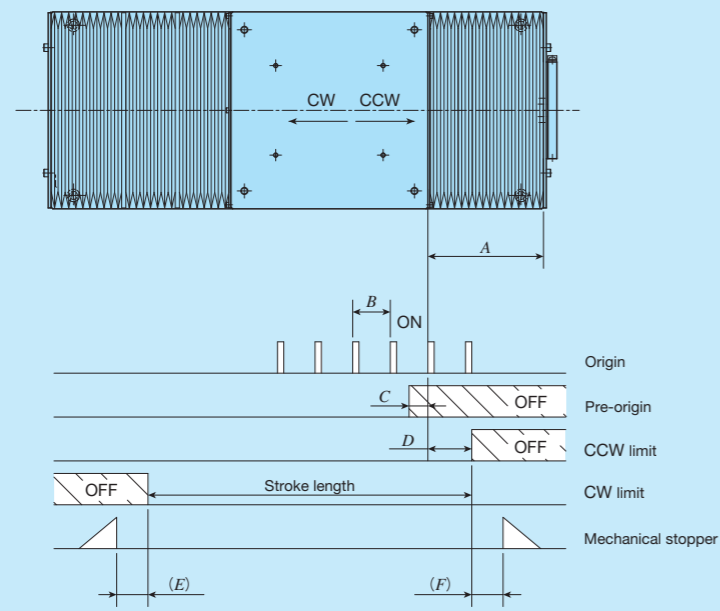

unit: mm

Model and size	Ball screw lead	A	B	C	D	E	F
TSLH120M-100/J	5	57.5	5	3	30	5	5
	10		10	7			
TSLH120M-150/J	5	62.5	5	3	30	5	5
	10		10	7			
TSLH120M-200/J	5	67.5	5	3	30	5	5
	10		10	7			
TSLH120M-250/J	5	72.5	5	3	30	5	5
	10		10	7			
TSLH120M-300/J	5	80	5	3	30	5	5
	10		10	7			
TSLH220M-150/J	5	65	5	3	30	7	5
	10		10	7		5	
TSLH220M-200/J	5	70	5	3	30	7	5
	10		10	7		5	
TSLH220M-250/J	5	80	5	3	30	7	5
	10		10	7		5	
TSLH220M-300/J	5	85	5	3	30	7	5
	10		10	7		5	
TSLH220M-400/J	5	95	5	3	30	7	5
	10		10	7		5	
TSLH320M-300/J	5	80	5	3	30	5	5
	10		10	7			
TSLH320M-400/J	5	90	5	3	30	5	5
	10		10	7			
TSLH320M-500/J	5	95	5	3	30	5	5
	10		10	7			
TSLH420M-500/J	5	90	5	3	30	5	5
	10		10	7			
TSLH420M-600/J	5	95	5	3	30	5	5
	10		10	7			
TSLH420M-800/J	5	115	5	3	30	5	5
	10		10	7			

Remarks 1. For detailed specifications of respective sensors, please see the section of sensor specification in General Explanation.
 2. The values of respective axes in tables of two-axis specification are the same as those of tables of single-axis specification.

Dimensions of Motor Attachment

TSLH120M, CTLH120M

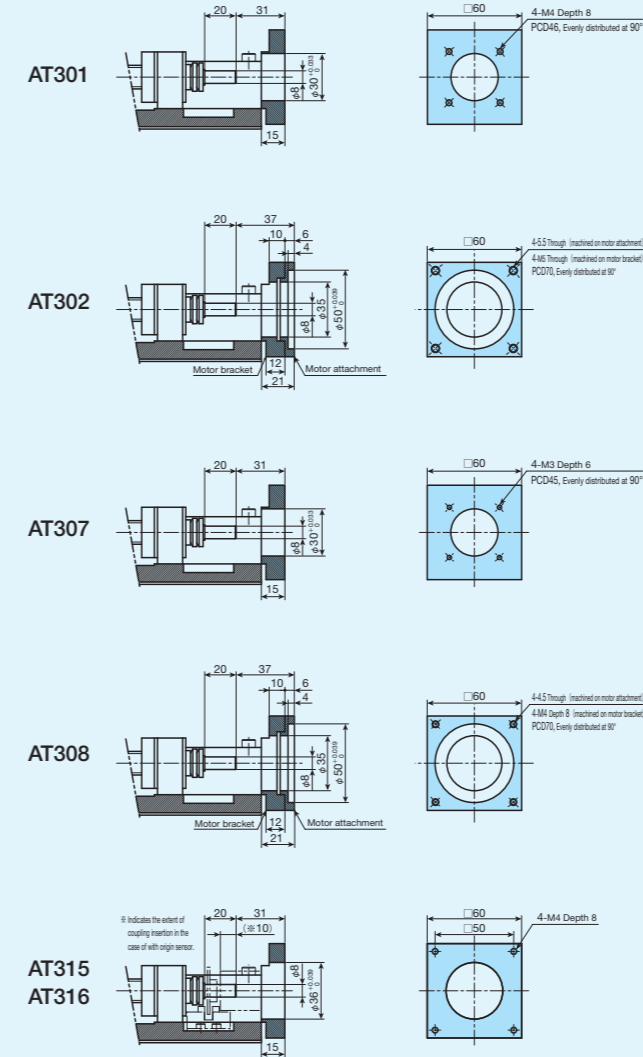

TSLH320M, CTLH320M

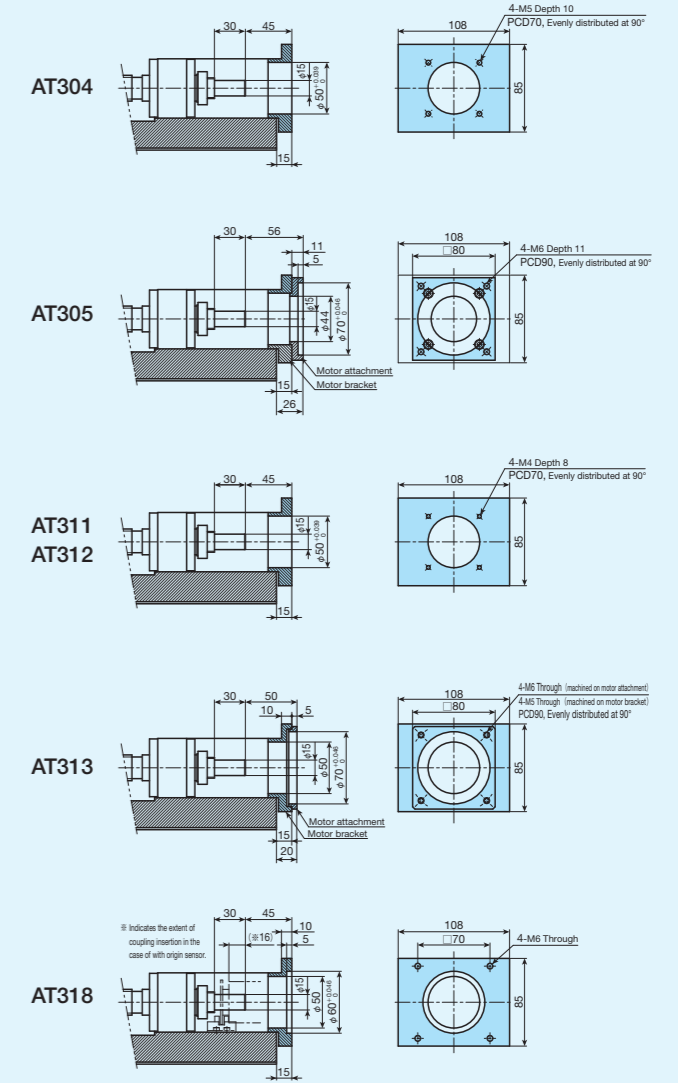

TSLH220M, CTLH220M

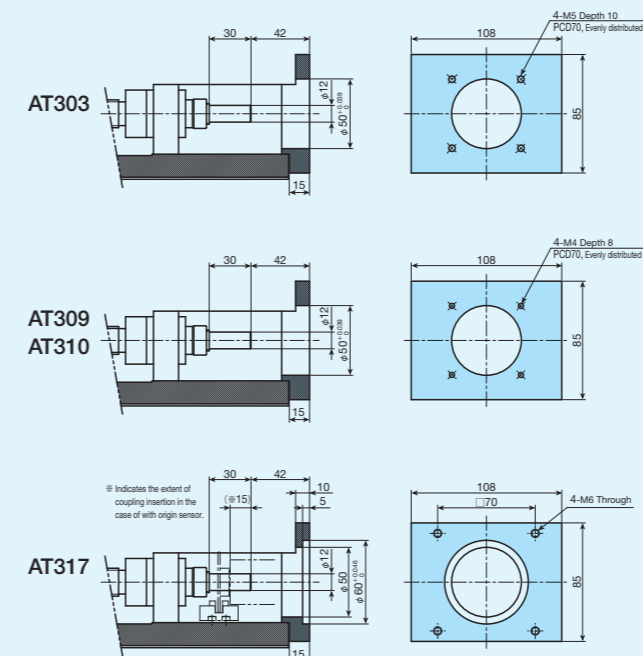

TSLH420M

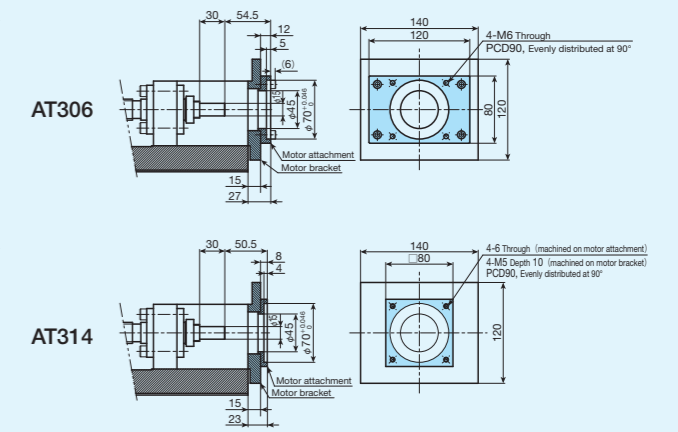

IKO Precision Positioning Table LH

TSLH120M

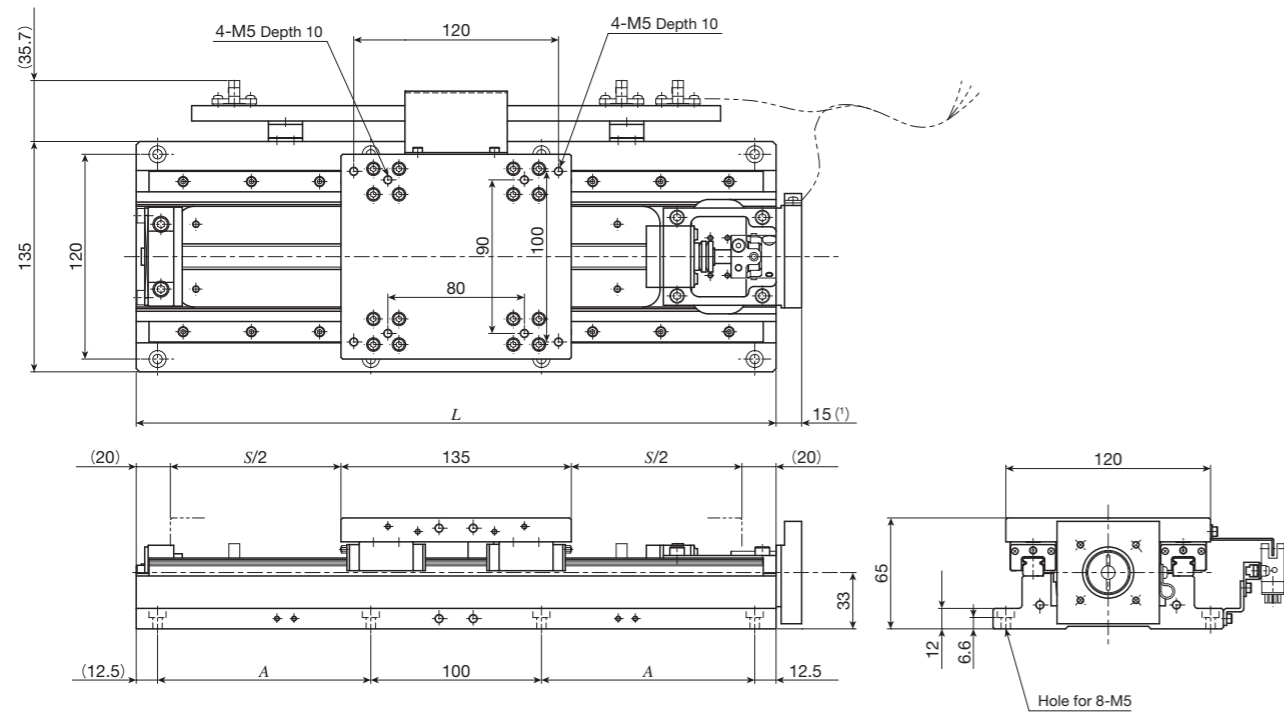

unit: mm

Identification number	Stroke length <i>S</i>	Overall length <i>L</i>	Mounting holes of bed <i>A</i>	Mass (Ref.) kg
TSLH120M-100	100	275	75	10
TSLH120M-150	150	325	100	11
TSLH120M-200	200	375	125	12
TSLH120M-250	250	425	150	13
TSLH120M-300	300	475	175	14

Note (1) When selecting AT302 or AT308, 21mm is applied.

TSLH220M

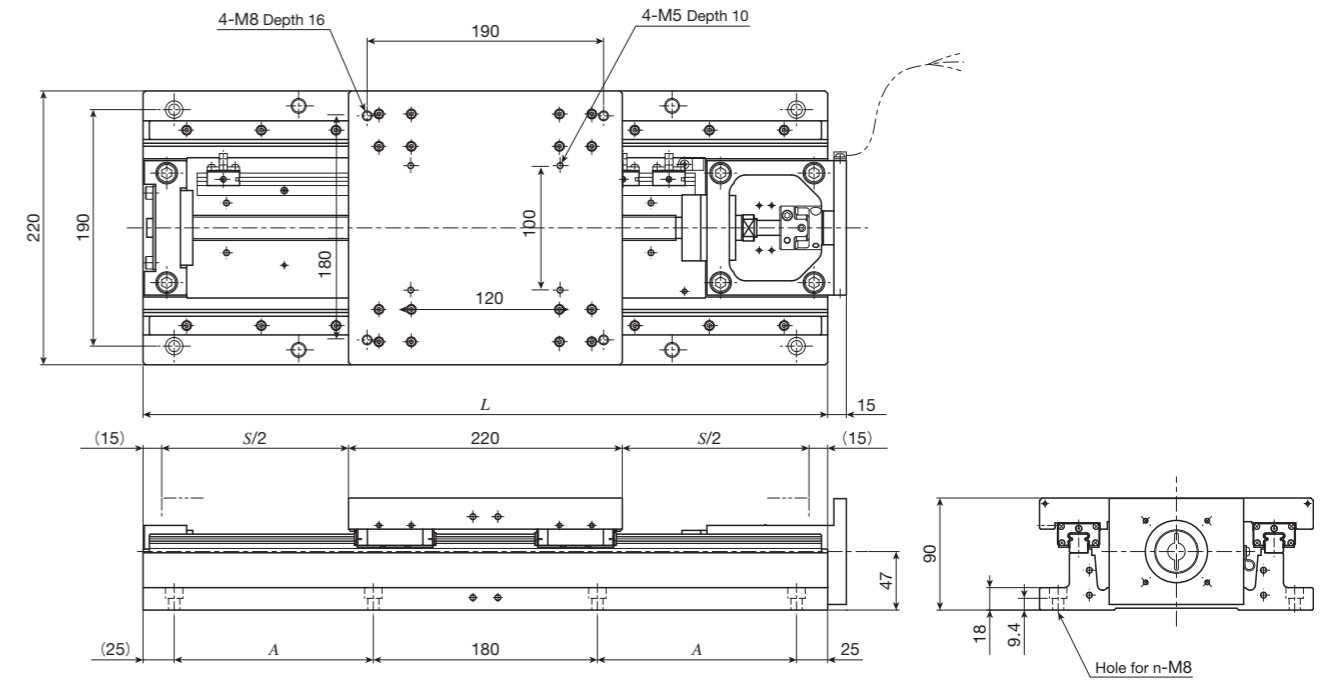

unit: mm

Identification number	Stroke length <i>S</i>	Overall length <i>L</i>	Mounting holes of bed		Mass (Ref.) kg
			<i>A</i> (the number of holes × pitch)	<i>n</i>	
TSLH220M-150	150	400	85	8	32
TSLH220M-200	200	450	110	8	34
TSLH220M-250	250	500	135	8	36
TSLH220M-300	300	550	160	8	38
(TSLH220M-500)	500	750	260 (2 × 130)	12	47
(TSLH220M-600)	600	850	310 (2 × 155)	12	51

Remark: If you are interested in a product of identification number shown in (), please contact IKO.

IKO Precision Positioning Table LH

TSLH320M

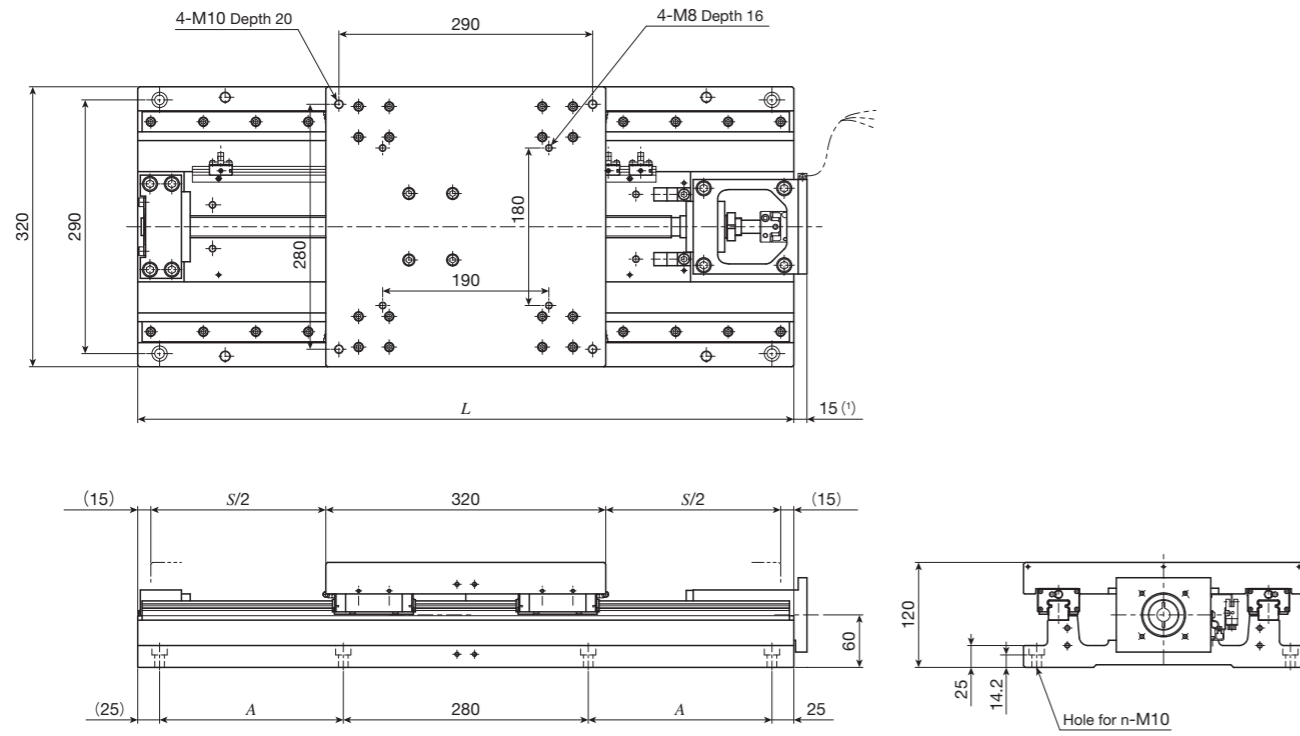

unit: mm

Identification number	Stroke length <i>S</i>	Overall length <i>L</i>	Mounting holes of bed		Mass (Ref.) kg
			<i>A</i> (the number of holes × pitch)	<i>n</i>	
TSLH320M- 300	300	650	160	8	100
TSLH320M- 400	400	750	210	8	109
TSLH320M- 500	500	850	260	8	118
(TSLH320M- 600)	600	950	310	8	127
(TSLH320M- 800)	800	1 150	410 (2×205)	12	146
(TSLH320M-1000)	1 000	1 350	510 (2×255)	12	164

Note (1) When selecting AT305, 26mm is applied. When selecting AT313, 20mm is applied.

Remark: If you are interested in a product of identification number shown in (), please contact IKO.

TSLH420M

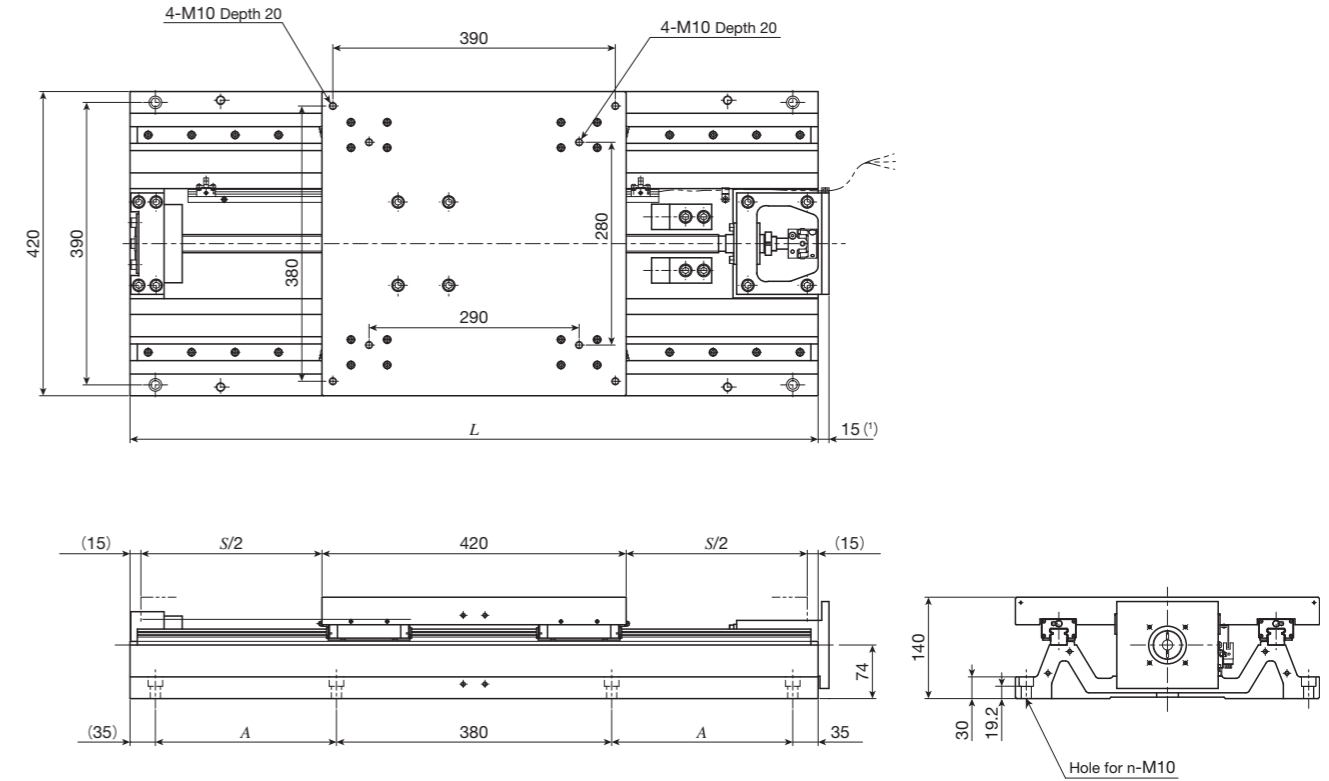

unit: mm

Identification number	Stroke length <i>S</i>	Overall length <i>L</i>	Mounting holes of bed		Mass (Ref.) kg
			<i>A</i> (the number of holes × pitch)	<i>n</i>	
TSLH420M- 500	500	950	250	8	176
TSLH420M- 600	600	1 050	300	8	188
TSLH420M- 800	800	1 250	400 (2×200)	12	212
(TSLH420M-1000)	1 000	1 450	500 (2×250)	12	237

Note (1) They represent the dimensions of motor bracket only. When selecting AT306, 27mm is applied. When selecting AT314, 23mm is applied.

Remark: If you are interested in a product of identification number shown in (), please contact IKO.

IKO Precision Positioning Table LH

CTLH120M

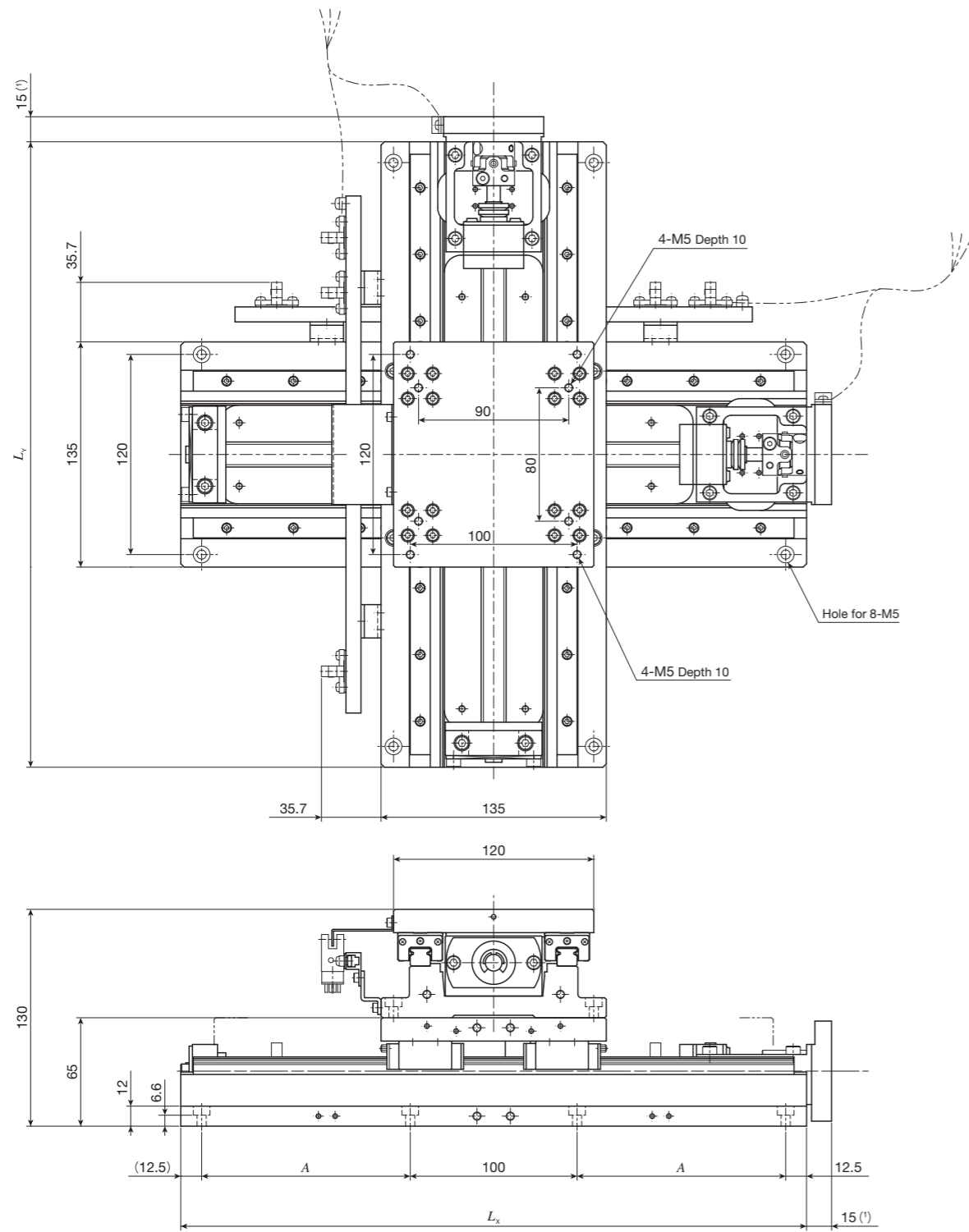

unit: mm

Identification number	Stroke length S		Overall length		Mounting holes of bed A	Mass (Ref.) kg
	X-axis	Y-axis	L_x	L_y		
CTLH120M-1010	100	100	275	275	75	20
CTLH120M-2010	200	100	375	275	125	22
CTLH120M-2020	200	200	375	375	125	24
CTLH120M-3020	300	200	475	375	175	26
CTLH120M-3030	300	300	475	475	175	28

Note (1) When selecting AT302 or AT308, 21mm is applied.

Remark: As a combination of stroke length other than listed above and a table of different size is possible, please contact IKO.

CTLH220M

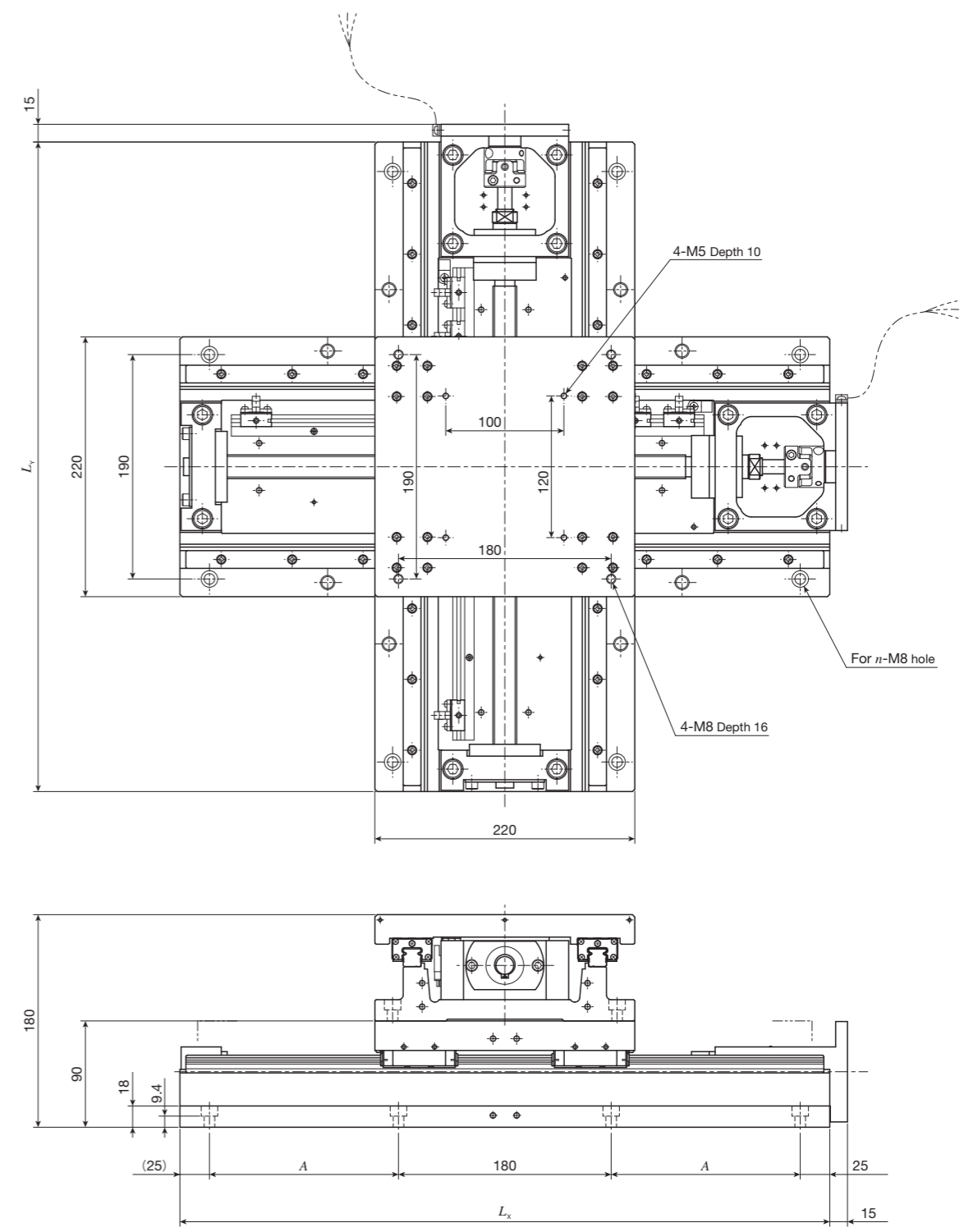

unit: mm

Identification number	Stroke length S		Overall length		Mounting holes of bed		Mass (Ref.) kg
	X-axis	Y-axis	L_x	L_y	A (the number of holes \times pitch)	n	
CTLH220M-2020	200	200	450	450	110	8	67
CTLH220M-3020	300	200	550	450	160	8	71
CTLH220M-3030	300	300	550	550	160	8	76
CTLH220M-4030	400	300	650	550	210 (2 \times 105)	12	80
CTLH220M-4040	400	400	650	650	210 (2 \times 105)	12	84

Remark: As a combination of stroke length other than listed above and a table of different size is possible, please contact IKO.

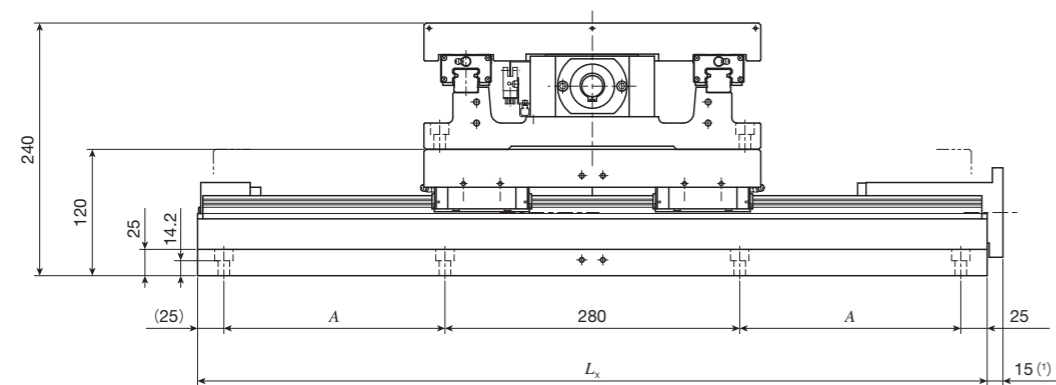
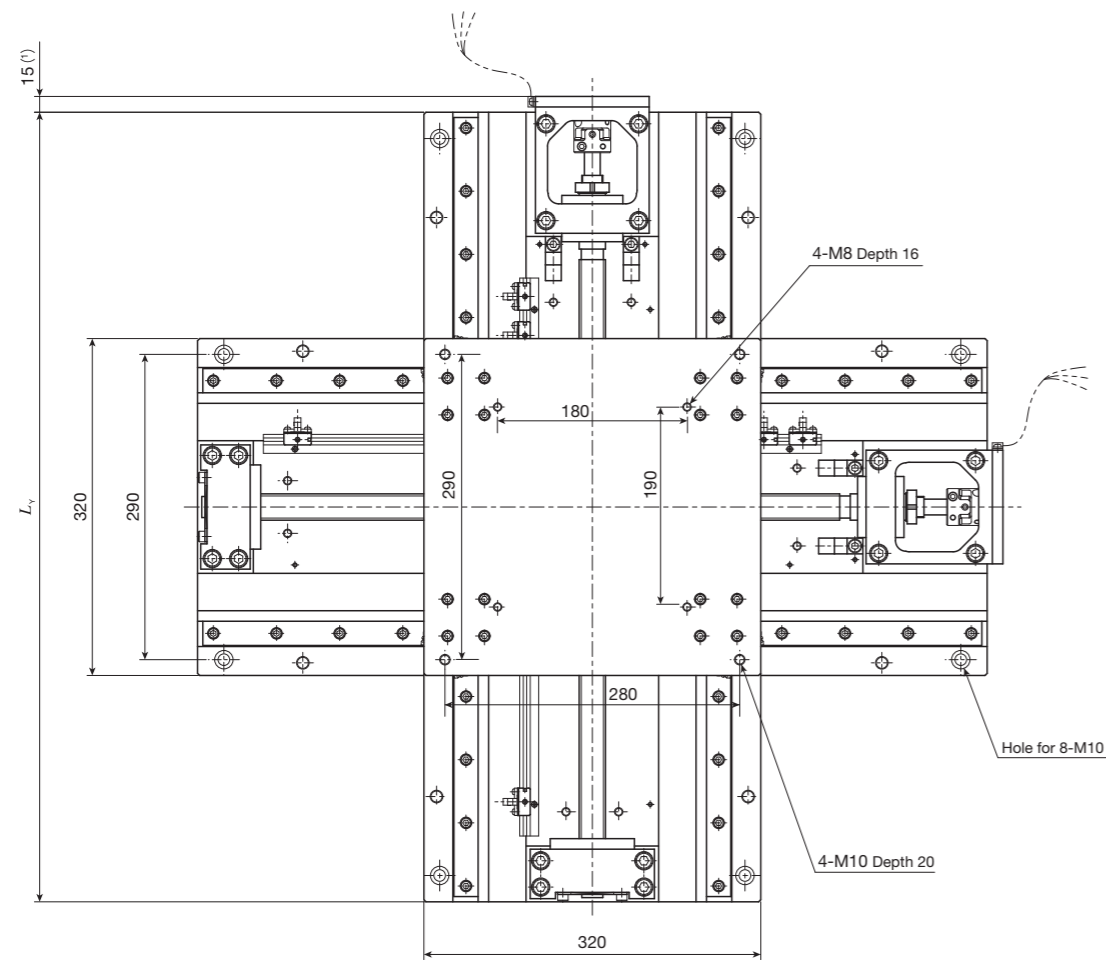

unit: mm

Identification number	Stroke length S		Overall length		Mounting holes of bed A	Mass (Ref.) kg
	X-axis	Y-axis	L_x	L_y		
CTLH320M-3030	300	300	650	650	160	199
CTLH320M-4030	400	300	750	650	210	209
CTLH320M-4040	400	400	750	750	210	218
CTLH320M-5040	500	400	850	750	260	227
CTLH320M-5050	500	500	850	850	260	236

Note (1) When selecting AT305, 26mm is applied. When selecting AT313, 20mm is applied.

Remark: As a combination of stroke length other than listed above and a table of different size is possible, please consult IKO.

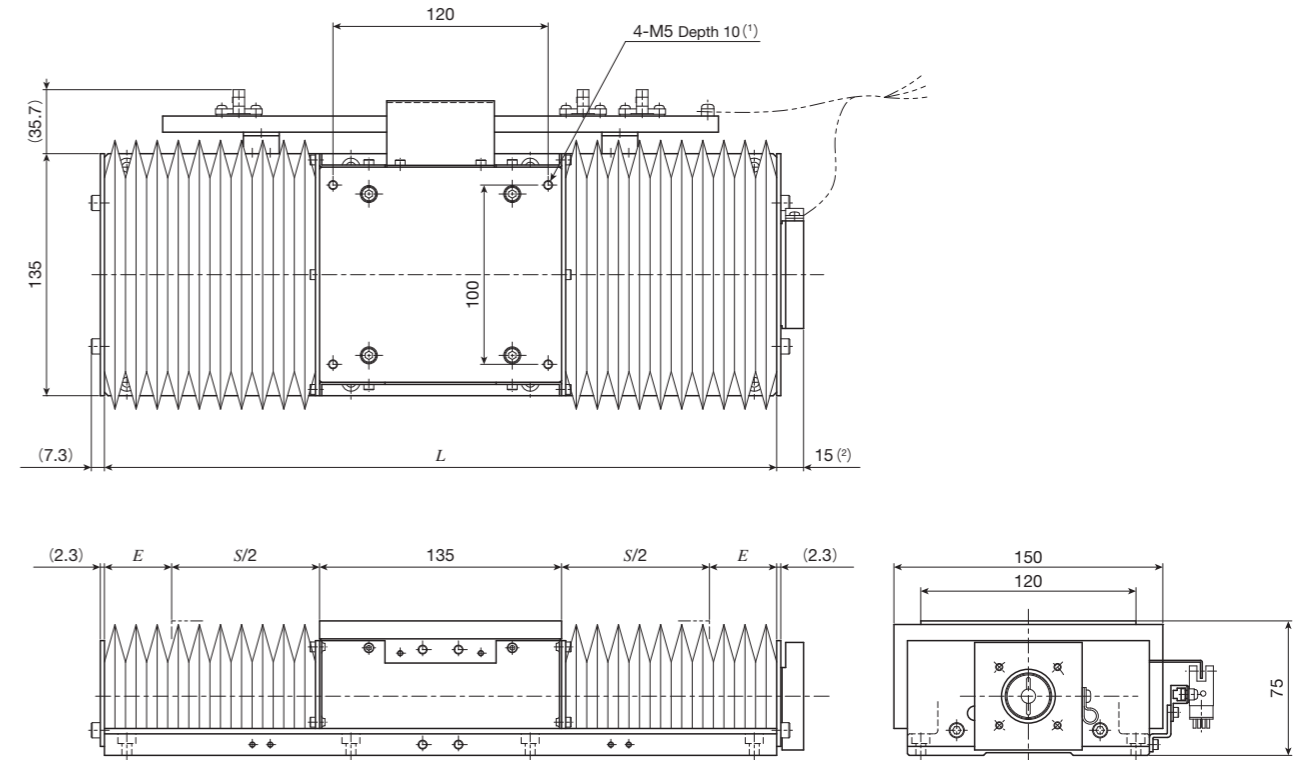

unit: mm

Identification number	Stroke length S	Overall length L	E	Mass (Ref.) kg
TSLH120M-100/J	85	275	27.5	13
TSLH120M-150/J	125	325	32.5	14
TSLH120M-200/J	165	375	37.5	15
TSLH120M-250/J	205	425	42.5	16
TSLH120M-300/J	240	475	50.0	17

Notes (1) Too deep insertion depth of the mounting bolt may affect the running performance of the moving table, so never insert a bolt longer than the depth of the through hole.

(2) When selecting AT302 or AT308, 21mm is applied.

Remarks 1. For the usage in vertical axis, the dimension of the bellows is different, so please contact IKO.

2. For bed mounting dimensions, see the dimension table for TSLH120M.

IKO Precision Positioning Table LH

TSLH220M.../J, TSLH320M.../J, TSLH420M.../J Table with bellows

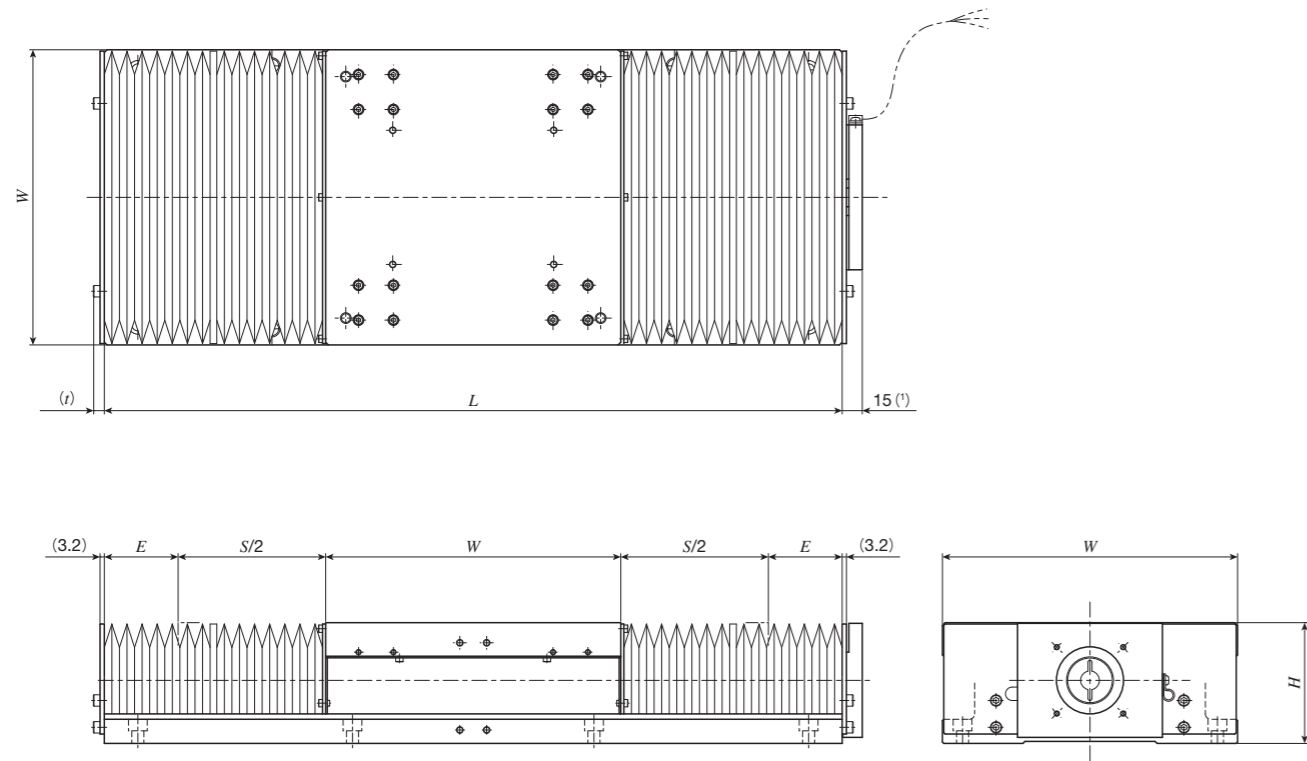

unit: mm

Identification number	Stroke length <i>S</i>	Overall length <i>L</i>	<i>W</i>	<i>H</i>	<i>E</i>	<i>t</i>	Mass (Ref.) kg
TSLH220M- 150/J	110	400	220	90	35	8.2	33
TSLH220M- 200/J	150	450			40		36
TSLH220M- 250/J	180	500			50		38
TSLH220M- 300/J	220	550			55		40
TSLH220M- 400/J	300	650			65		44
(TSLH220M- 500/J)	370	750			80		49
(TSLH220M- 600/J)	440	850			95		53
TSLH320M- 300/J	230	650	320	120	50	9.2	104
TSLH320M- 400/J	310	750			60		113
TSLH320M- 500/J	400	850			65		129
(TSLH320M- 600/J)	480	950			75		131
(TSLH320M- 800/J)	640	1 150			95		151
(TSLH320M-1000/J)	800	1 350	115	169			
TSLH420M- 500/J	410	950	420	140	60	10.5	183
TSLH420M- 600/J	500	1 050			65		195
TSLH420M- 800/J	660	1 250			85		219
(TSLH420M-1000/J)	830	1 450			100		244

Note (1) When selecting AT305, 26mm is applied. When selecting AT306, 27mm is applied.
When selecting AT313, 20mm is applied. When selecting AT314, 23mm is applied.

Remarks 1. For the usage in vertical axis, the dimension of the bellows is different, so please contact IKO.

2. If you are interested in a product of identification number shown in (), please contact IKO.

3. For mounting dimensions, see the dimension tables for TSLH220M, TSLH320M, and TSLH420M.

CTLH120M.../J Table with bellows

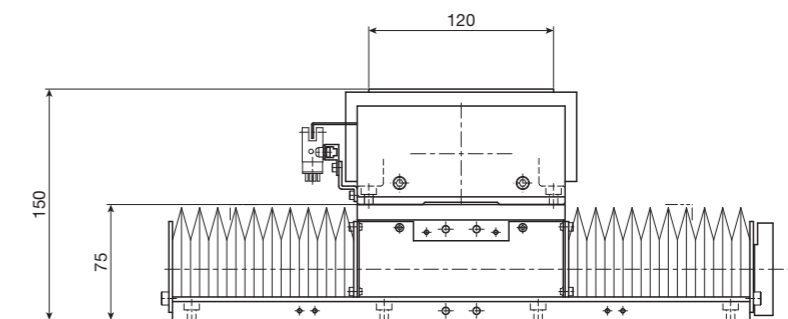
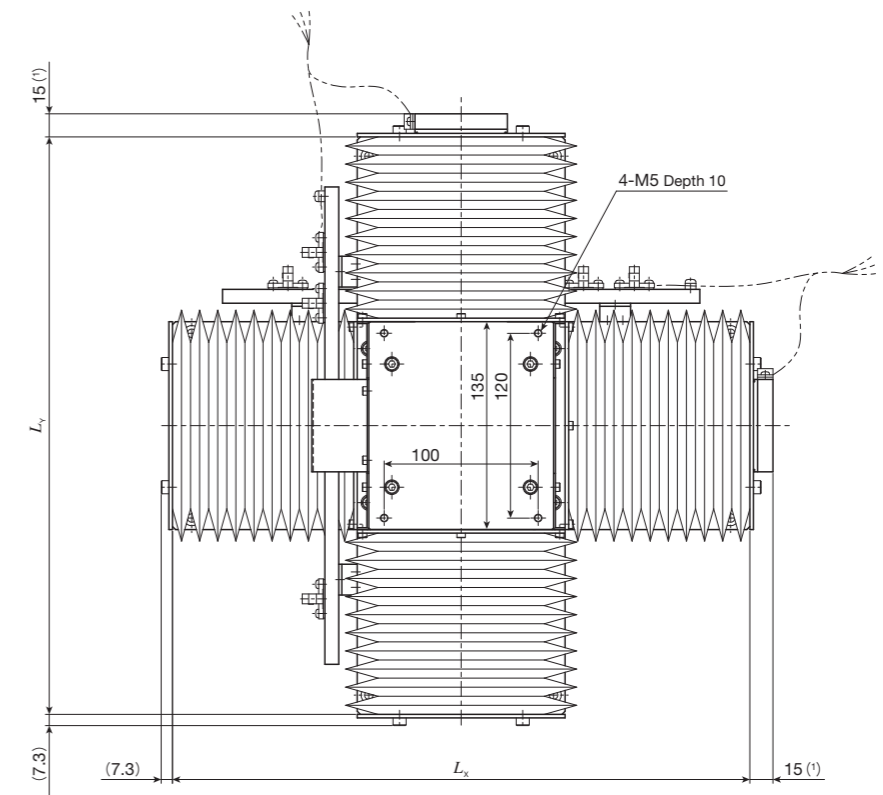

unit: mm

Identification number	Stroke length <i>S</i>		Overall length of bed		Mass (Ref.) kg
	X-axis	Y-axis	<i>L_x</i>	<i>L_y</i>	
CTLH120M-1010/J	85	85	275	275	25
CTLH120M-2010/J	165	85	375	275	27
CTLH120M-2020/J	165	165	375	375	29
CTLH120M-3020/J	240	165	475	375	31
CTLH120M-3030/J	240	240	475	475	33

Note (1) When selecting AT302 or AT308, 21mm is applied.

Remarks 1. For the usage in vertical axis, the dimension of the bellows is different, so please contact IKO.

2. For mounting dimensions, see the dimension table for TSLH120M.

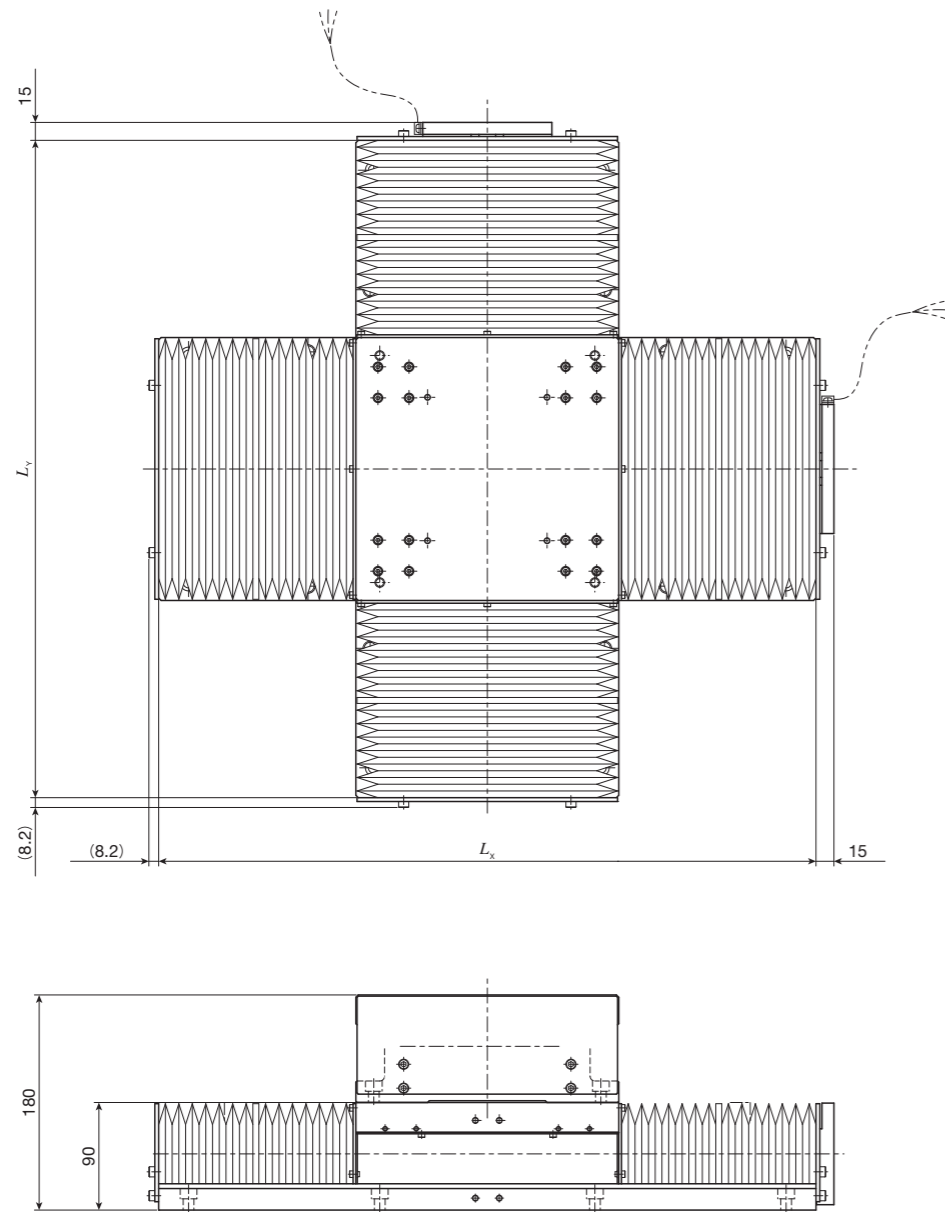

unit: mm

Identification number	Stroke length S		Overall length of bed		Mass (Ref.) kg
	X-axis	Y-axis	L_x	L_y	
CTLH220M-2020/J	150	150	450	450	71
CTLH220M-3020/J	220	150	550	450	75
CTLH220M-3030/J	220	220	550	550	80
CTLH220M-4030/J	300	220	650	550	84
CTLH220M-4040/J	300	300	650	650	88

Remarks 1. For the usage in vertical axis, the dimension of the bellows is different, so please contact IKO.
2. For mounting dimensions, see the dimension table for TSLH220M.

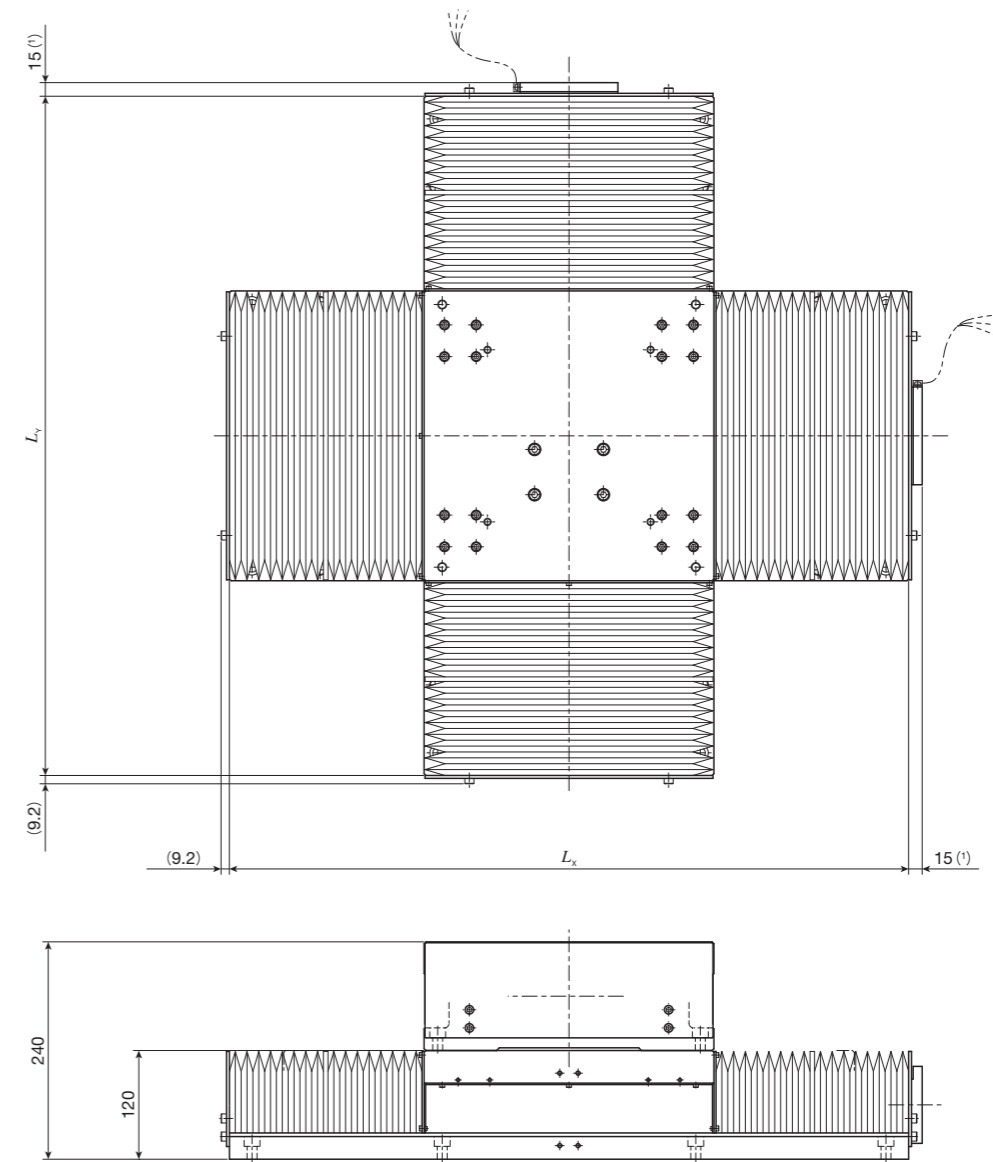

unit: mm

Identification number	Stroke length S		Overall length of bed		Mass (Ref.) kg
	X-axis	Y-axis	L_x	L_y	
CTLH320M-3030/J	230	230	650	650	207
CTLH320M-4030/J	310	230	750	650	216
CTLH320M-4040/J	310	310	750	750	226
CTLH320M-5040/J	400	310	850	750	235
CTLH320M-5050/J	400	400	850	850	244

Note (1) When selecting AT305, 26mm is applied. When selecting AT313, 20mm is applied.
Remarks 1. For the usage in vertical axis, the dimension of the bellows is different, so please contact IKO.
2. For mounting dimensions, see the dimension table for TSLH320M.