

**TS / CT**

TS / CT

TS

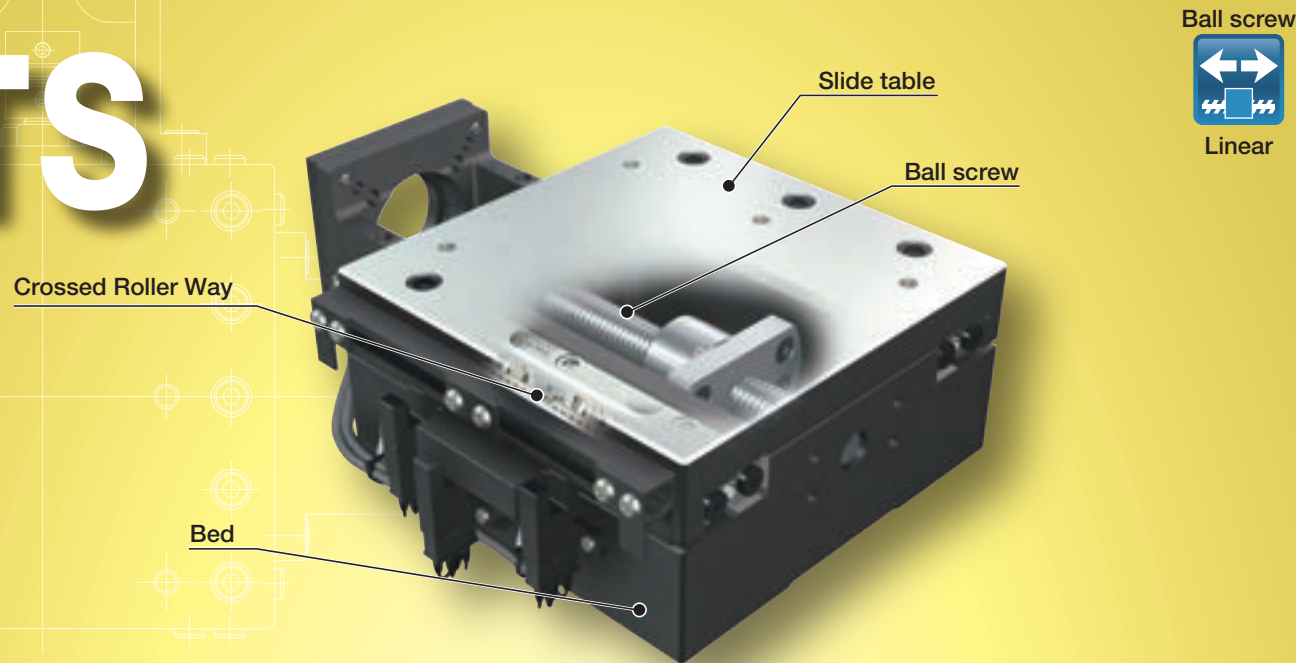

CT

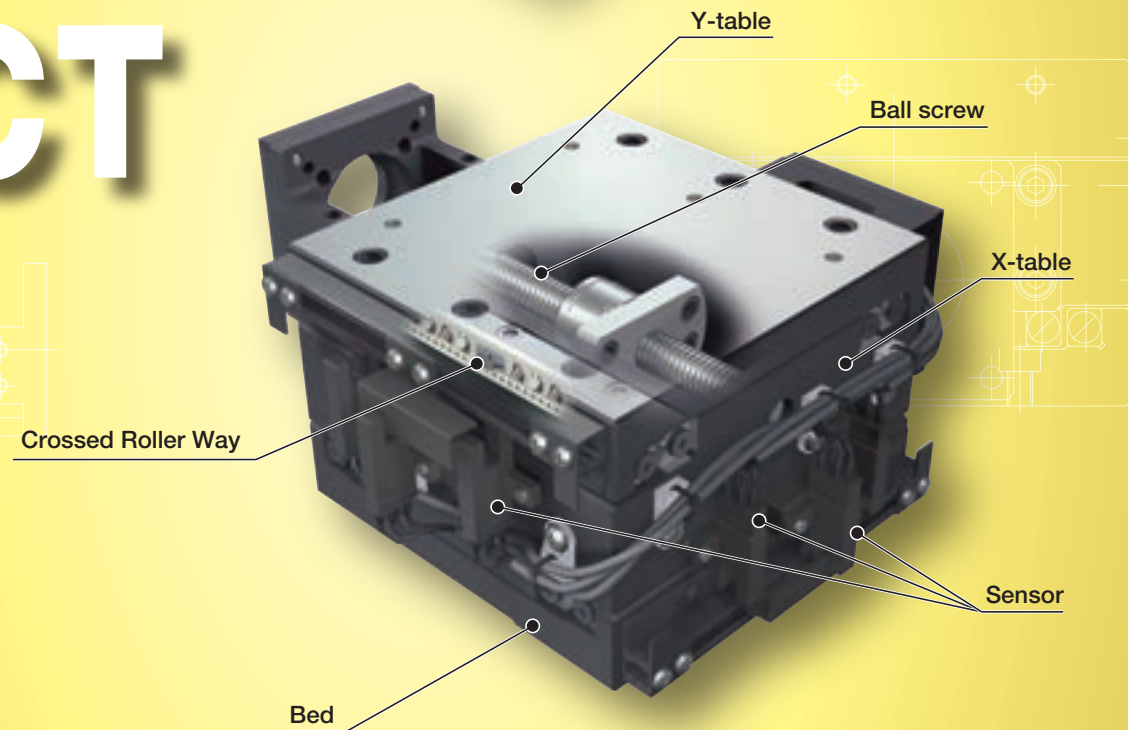

Major product specifications

Driving method	Precision ball screw
Linear motion rolling guide	Crossed Roller Way
Built-in lubrication part	No built-in
Material of table and bed	Cast iron
Sensor	Select by identification number

Accuracy

Positioning repeatability	±0.002
Positioning accuracy	0.005~0.015
Lost motion	-
Parallelism in table motion A	0.005~0.008
Parallelism in table motion B	0.015~0.020
Attitude accuracy	-
Straightness	-
Backlash	-

unit: mm

# Points

## 1 High precision and compact positioning table

High precision and compact positioning table incorporating Crossed Roller Way into high rigidity and vibration damping performance cast iron slide tables and beds.

## 2 Safety design with retainer creep proof function

Adoption of Anti-Creep Cage Crossed Roller Way that does not cause retainer creep in the linear motion rolling guide allows you to safely use the table even in vertical axis use and high acceleration / deceleration operation. (TS55/55 and CT55/55 are not included.)

## 3 Optimal for works directly conducted on the table upper surface

Adoption of large precisely polished table allows you to use the entire table upper surface as work space.

### Structure and features of Anti-Creep Cage Crossed Roller Way

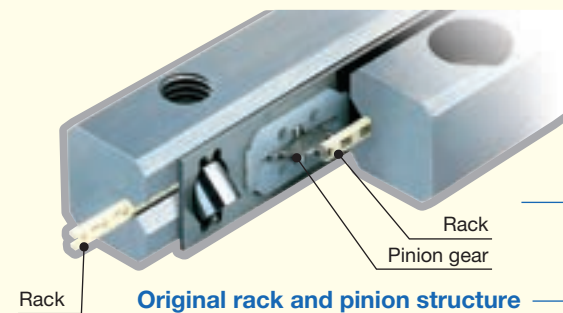

No retainer creep even under high-tact operation in vertical axis !

(Durability test) Test conditions

Model number	CRWG 3	
Test method	Vibration test machine	
Operating conditions	Posture	Vertical
	Maximum speed	827 mm/s
	Acceleration	15 G
	Cycle	31 Hz
	Stroke	8 mm
Mass of moving table	330 g	
Number of strokes	100 million strokes	

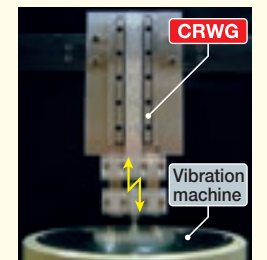

(Result) No retainer creep nor material damage in any component is found.

### Variation

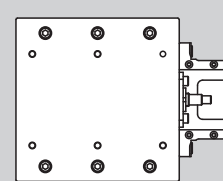
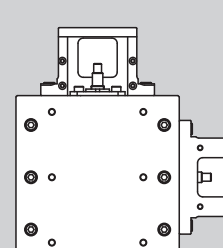
Shape	Model	Table width (mm)	Table length (mm)					
			55	75	125	220	310	350
Single-axis specification 	TS	55	☆	-	-	-	-	-
		75	-	☆	-	-	-	-
		125	-	-	☆	☆	-	-
		220	-	-	-	☆	☆	-
		260	-	-	-	-	-	☆
Two-axis specification 	CT	55	☆	-	-	-	-	-
		75	-	☆	-	-	-	-
		125	-	-	☆	-	-	-
		220	-	-	-	☆	-	-
		260	-	-	-	-	-	☆
		350	-	-	-	-	-	☆

☆ uses Anti-Creep Cage Crossed Roller Way.

1N=0.102kgf=0.2248lbs.  
1mm=0.03937inch

# Identification Number

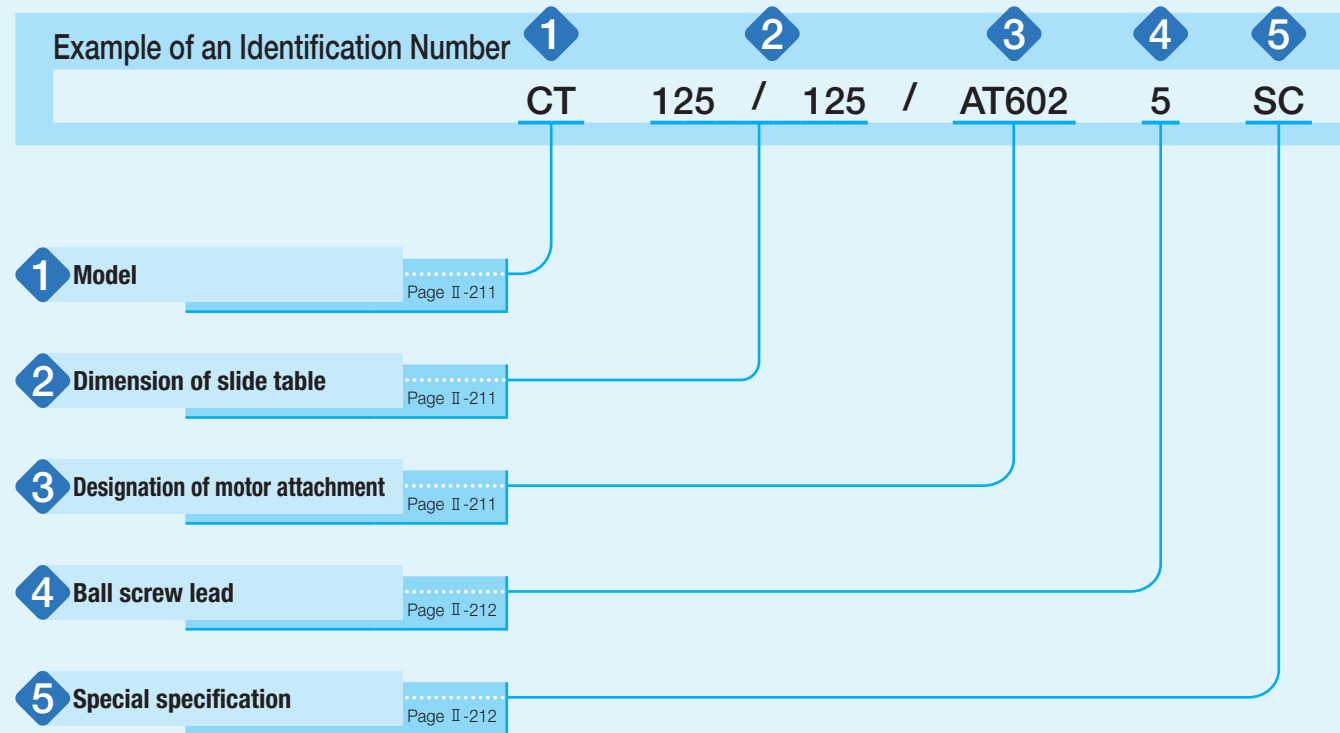

# Identification Number and Specification

- 1 Model** TS : Precision Positioning Table TS (single-axis specification)  
CT : Precision Positioning Table CT (two-axis specification)
- 2 Dimension of slide table** Select a dimension for slide table from the list of Table 1.
- Width and length of slide table are indicated in mm. For CT (two-axis specification), width and length of Y-table are indicated.

Table 1 Models of linear motion rolling guide/slide table dimension and stroke length

unit: mm

Model	Linear motion rolling guide	Width/length	Stroke length
TS	Crossed Roller Way	55/ 55	15
		75/ 75	25
		125/125	50
	Anti-Creep Cage Crossed Roller Way	125/220	120
		220/220	120
		220/310	180
CT	Crossed Roller Way	55/ 55	X-axis: 15, Y-axis: 15
		75/ 75	X-axis: 25, Y-axis: 25
	Anti-Creep Cage Crossed Roller Way	125/125	X-axis: 50, Y-axis: 50
		220/220	X-axis: 120, Y-axis: 120
		260/350	X-axis: 150, Y-axis: 250
		350/350	X-axis: 250, Y-axis: 250

- 3 Designation of motor attachment** As for a motor attachment, select it from the list of Table 2.
- Motor should be prepared by customer.
  - Please specify motor attachment applicable to motor for use.
  - A coupling shown in Table 3 is mounted on the main body before shipment. However, the final position adjustment should be made by customer since it is only temporarily fixed.

# Identification Number and Specification

Table 2 Application of motor attachment

Type	Motor to be used				Flange size mm	Motor attachment			
	Manufacturer	Series	Model	Rated output W		TS55/55 TS75/75 CT55/55 CT75/75	TS125/125 TS220/220 CT125/125 CT220/220	TS220/310	TS260/350 CT260/350 CT350/350
AC servomotor	YASKAWA ELECTRIC CORPORATION	Σ-7	SGM7J-01A	100	□40	—	AT602	AT604	—
			SGM7A-01A			—	AT602	AT604	—
			SGM7J-02A	200	□60	—	—	—	AT606
			SGM7A-02A			—	—	—	AT606
	Mitsubishi Electric Corporation	J4/J5	HG-MR13	100	□40	—	AT602	AT604	—
			HG-KR13/HK-KT13W			—	AT602	AT604	—
			HG-MR23	200	□60	—	—	—	AT606
			HG-KR23/HK-KT23W			—	—	—	AT606
	Panasonic Corporation	MINAS A6	MSMF01	100	□38	—	AT603	AT605	—
			MSMF02	200	□60	—	—	—	AT607
Hitachi Industrial Equipment Systems Co., Ltd	AD	ADMA-01L	100	□40	—	AT602	AT604	—	
		ADMA-02L	200	□60	—	—	—	AT606	
Stepper Motor	ORIENTAL MOTOR Co., Ltd.	PK	PK544-A		□38	AT601	—	—	
		RKS · CRK	CRK56 <sup>(1)</sup>		□60	—	AT608	AT609	
		RKS59			□85	—	—	AT610	

Note <sup>(1)</sup> Applicable to the outer diameter  $\phi 8$  of motor output shaft.  
Remark: For detailed motor specifications, please see respective motor manufacturer's catalog.

Table 3 Coupling models

Motor attachment	Coupling models	Manufacturer	Coupling inertia $J_c$ $\times 10^{-5} \text{kg} \cdot \text{m}^2$
AT601	MWSS-12- 5× 5	Nabeya Bi-tech Kaisha	0.018
AT602	MSTS-25C- 8× 8	Nabeya Bi-tech Kaisha	0.71
AT603	MSTS-25C- 8× 8	Nabeya Bi-tech Kaisha	0.71
AT604	MSTS-25C- 6× 8	Nabeya Bi-tech Kaisha	0.71
AT605	MSTS-25C- 6× 8	Nabeya Bi-tech Kaisha	0.71
AT606	MSTS-32C-12× 14	Nabeya Bi-tech Kaisha	2.7
AT607	MSTS-32C-11× 12	Nabeya Bi-tech Kaisha	2.7
AT608	MSTS-19C- 6× 8	Nabeya Bi-tech Kaisha	0.277
AT609	MSTS-25C- 6× 8	Nabeya Bi-tech Kaisha	0.71
AT610	MSTS-32C-12× 14	Nabeya Bi-tech Kaisha	2.7

Remark: For detailed coupling specifications, please see respective manufacturer's catalogs.

- 4 Ball screw lead** 1: Lead 1mm (applicable to 55/55, 75/75, and 125/125)  
2: Lead 2mm (not applicable to 55/55 or 75/75)  
5: Lead 5mm (not applicable to 55/55 or 75/75)
- 5 Special specification** No symbol: Standard specification  
BE : Option base (applicable to 55/55)  
LR : Black chrome surface treatment  
SC : Table with sensor
- Option base : Base plate is available for attaching the main body downward. For detailed information, please see the dimension table.
- Black chrome surface treatment : A black permeable film is formed on the surface to improve corrosion resistance. This treatment is performed on the surfaces of slide table, bed, and motor bracket. For the reference surfaces of respective parts, surface treatment is excluded.
- Table with sensors : A set of limit sensor, pre-origin sensor, and origin sensor is attached. However, when selecting an AC servomotor attachment, an origin sensor is not provided. Please use the C-phase or Z-phase of the encoder.

Remark: When using multiple special specifications for combination, please indicate by arranging supplemental codes in alphabetical order.

# Specifications

**Table 4 Accuracy**

unit: mm

Identification number		Positioning repeatability	Positioning accuracy	Parallelism in table motion A	Parallelism in table motion B	Squareness of XY motion <sup>(1)</sup> <sup>(2)</sup>	
Single-axis specification	Two-axis specification						
TS 55/ 55	—	±0.002	0.005	0.005	0.015	0.005	
—	CT 55/ 55		0.010				
TS 75/ 75	CT 75/ 75		0.005				
TS125/125	CT125/125		0.008	0.008	0.008	0.020	0.008
TS220/220	CT220/220						
TS220/310	—						
TS260/350	CT260/350						
—	CT350/350						

Note <sup>(1)</sup> Applied to tables with two-axis specification.  
<sup>(2)</sup> Does not contain a straightness component.

**Table 5 Maximum speed**

Motor type	Maximum speed mm/s		
	Lead 1mm	Lead 2mm	Lead 5mm
AC servomotor	50	100	250
Stepper motor	30	60	150

Remark: To measure the practical maximum speed, it is required to consider operation patterns based on the motor to be used and load conditions.

**Table 6.1 Maximum carrying mass of TS**

Model and size	Ball screw lead mm	Carrying mass center of gravity mm	Maximum carrying mass kg								
			Length L	Horizontal direction				Vertical direction			
				Height H	0	100	200	300	0	100	200
TS 55/ 55	1	0	4.3	4.2	2.3	1.6	2.2	0.9	0.5	0.3	
			100	4.3	4.2	2.3	1.5	1.1	0.6	0.4	0.3
			200	4.3	4.1	2.2	1.5	0.6	0.4	0.3	0.2
			300	4.3	4.0	2.2	1.5	0.4	0.3	0.2	0.2
TS 75/ 75	1	0	21	21	12	8	1.5	1.5	1.5	1.3	
			100	21	21	12	8	1.5	1.5	1.5	1.1
			200	21	20	11	8	1.5	1.5	1.3	1.0
			300	21	20	11	8	1.5	1.2	1.0	0.8
TS125/125	1	0	72	72	59	42	2.3	2.3	2.3	2.3	
			100	72	72	57	41	2.3	2.3	2.3	2.3
			200	72	72	55	40	2.3	2.3	2.3	2.3
			300	72	72	54	39	2.3	2.3	2.3	2.3
	2	0	72	72	45	32	11	11	7	5	
			100	72	69	42	30	11	10	6	4.7
			200	72	62	40	29	9	6	5	4.1
			300	72	56	37	28	6	5	4.4	3.7
	5	0	72	49	28	20	29	11	5	4.0	
			100	72	38	24	18	12	7	4.8	3.5
			200	54	31	21	16	6	5	4.1	3.1
			300	40	26	19	15	4.8	3.9	3.3	2.8
TS125/220	2	0	115	114	67	47	9	9	9	9	
			100	115	104	64	46	9	9	9	9
			200	115	96	60	44	9	9	9	8
			300	115	88	57	42	9	9	8	7
	5	0	115	75	44	31	28	21	11	8	
			100	115	61	39	29	22	14	9	6
			200	94	51	35	26	12	9	7	6
			300	71	44	31	24	8	7	6	5
TS220/220	2	0	169	169	169	130	3.9	3.9	3.9	3.9	
			100	169	169	164	123	3.9	3.9	3.9	3.9
			200	169	169	152	116	3.9	3.9	3.9	3.9
			300	169	169	142	110	3.9	3.9	3.9	3.9
	5	0	169	169	109	80	24	24	20	14	
			100	169	134	92	70	24	24	17	12
			200	169	108	79	63	23	17	14	10
			300	129	90	69	56	16	13	11	9
TS220/310	2	0	256	256	256	197	—	—	—	—	
			100	256	256	249	187	—	—	—	—
			200	256	256	233	178	—	—	—	—
			300	256	256	218	169	—	—	—	—
	5	0	282	267	169	124	19	19	19	19	
			100	282	209	144	110	19	19	19	19
			200	266	170	125	98	19	19	19	18
			300	204	143	110	89	19	19	18	16
TS260/350	2	0	310	310	310	242	—	—	—	—	
			100	310	310	305	232	—	—	—	—
			200	310	310	288	222	—	—	—	—
			300	310	310	272	212	—	—	—	—
	5	0	310	310	208	154	18	18	18	18	
			100	310	258	181	139	18	18	18	18
			200	310	216	159	126	18	18	18	18
			300	263	185	142	115	18	18	18	18

Remarks 1. Not operable when the maximum carrying mass is "-".  
 2. The maximum carrying mass is adjusted by the mass when the rating life of the linear motion rolling guide, ball screws, or bearings is 18,000 hours during continuous operation at a number of revolutions of the motor of 3000min<sup>-1</sup> and an acceleration/deceleration time of 0.2s. The mass calculated is based upon the basic static load rating of the linear motion rolling guide.  
 3. Please refer to the carrying mass center of gravity diagrams on page II-216 for details on length L and height H.  
 4. Please also check the maximum load mass on page III-20.



Table 6.2 Maximum carrying mass of CT

Model and size	Ball screw lead mm	Carrying mass center of gravity mm	Maximum carrying mass kg							
			Horizontal direction				Vertical direction <sup>(1)</sup>			
			Length L	0	100	200	300	0	100	200
CT 55/ 55	1	0	4.3	4.1	2.2	1.5	2.2	0.9	0.5	0.3
		100	4.3	4.1	2.2	1.5	1.1	0.6	0.4	0.2
		200	4.3	4.0	2.2	1.5	0.6	0.4	0.3	0.2
		300	4.3	3.9	2.2	1.5	0.4	0.3	0.2	0.2
CT 75/ 75	1	0	21	21	12	8	1.5	1.5	1.5	1.2
		100	21	21	11	8	1.5	1.5	1.5	1.1
		200	21	20	11	8	1.5	1.5	1.3	0.9
		300	21	20	11	8	1.4	1.2	1.0	0.8
CT125/125	1	0	72	72	58	41	2.3	2.3	2.3	2.3
		100	72	72	57	40	2.3	2.3	2.3	2.3
		200	72	72	55	39	2.3	2.3	2.3	2.3
		300	72	72	53	39	2.3	2.3	2.3	2.3
		300	72	72	53	39	2.3	2.3	2.3	2.3
	2	0	72	72	44	31	11	11	7	5
		100	72	68	42	30	11	9	6	4.5
		200	72	61	39	29	8	6	5	4.0
		300	72	55	37	27	6	4.9	4.2	3.6
	5	0	72	48	28	20	29	10	5	3.9
		100	72	37	24	18	11	7	4.7	3.4
		200	53	30	21	16	6	4.8	3.8	3.0
300		39	25	18	14	4.4	3.6	3.0	2.6	
CT220/220	2	0	169	169	169	128	3.9	3.9	3.9	3.9
		100	169	169	162	121	3.9	3.9	3.9	3.9
		200	169	169	151	115	3.9	3.9	3.9	3.9
		300	169	169	140	109	3.9	3.9	3.9	3.9
	5	0	169	169	108	78	24	24	20	13
		100	169	132	91	69	24	24	16	12
		200	167	107	78	61	22	16	13	10
		300	127	89	68	55	15	12	10	9
CT260/350	2	0	225	225	225	181	-	-	-	-
		100	225	225	225	173	-	-	-	-
		200	225	225	216	166	-	-	-	-
		300	225	225	204	159	-	-	-	-
	5	0	225	225	151	112	18	18	18	18
		100	225	188	132	101	18	18	18	18
		200	225	158	117	92	18	18	18	17
		300	194	136	104	84	18	18	16	14
CT350/350	2	0	286	286	286	286	-	-	-	-
		100	286	286	286	277	-	-	-	-
		200	286	286	286	262	-	-	-	-
		300	286	286	286	248	-	-	-	-
	5	0	310	310	229	174	14	14	14	14
		100	310	265	194	153	14	14	14	14
		200	309	218	168	137	14	14	14	14
		300	245	184	148	123	14	14	14	14

Note <sup>(1)</sup> When the Y-axis moves vertically.

Remarks 1. Not operable when the maximum carrying mass is "-".

2. The maximum carrying mass is adjusted by the mass when the rating life of the linear motion rolling guide, ball screws, or bearings is 18,000 hours during continuous operation at a number of revolutions of the motor of 3000min<sup>-1</sup> and an acceleration/deceleration time of 0.2s. The mass calculated is based upon the basic static load rating of the linear motion rolling guide.

3. Please refer to the carrying mass center of gravity diagrams on page II-216 for details on length L and height H.

4. Please also check the maximum load mass on page III-20.

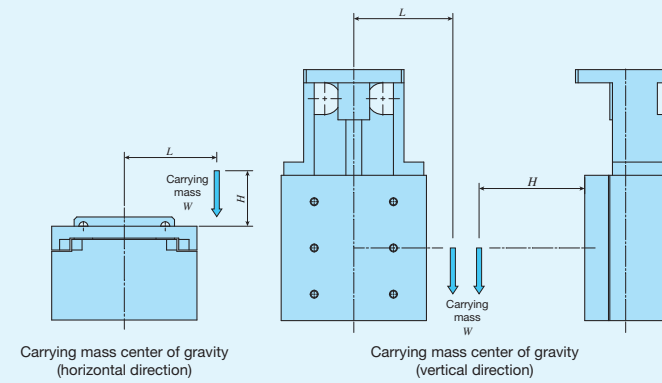

Table 7 Specifications of ball screw

unit: mm

Model and size	Ball screw lead	Axis name	Shaft dia.	Overall length	
Single-axis specification	TS 55/ 55	-	6	68	
	TS 75/ 75	-	6	89	
	TS125/125	1	-	12	148
		2	-	12	148
	TS125/220	5	-	14	148
		2	-	12	269
	TS220/220	5	-	14	269
		2	-	14	269
	TS220/310	5	-	14	389
		2	-	14	389
Two-axis specification	TS260/350	-	20	435	
	CT 55/ 55	1	X-axis, Y-axis	6	68
		1	X-axis, Y-axis	6	89
	CT125/125	1	X-axis, Y-axis	12	148
		2	X-axis, Y-axis	12	148
		5	X-axis, Y-axis	14	148
	CT220/220	2	X-axis, Y-axis	14	269
		5	X-axis, Y-axis	14	269
	CT260/350	2	X-axis	20	330
			Y-axis	20	435
5		X-axis	20	330	
		Y-axis	20	435	
CT350/350	2	X-axis, Y-axis	20	435	
	5	X-axis, Y-axis	20	435	

Table 8 Table inertia and starting torque

Identification number	Table inertia $J_T$ $\times 10^{-5} \text{kg} \cdot \text{m}^2$			Starting torque $T_s$ N·m		
	Lead 1mm	Lead 2mm	Lead 5mm			
Single-axis specification	TS 55/ 55	0.01	-	-	0.03	
	TS 75/ 75	0.01	-	-	0.03	
	TS125/125	0.20	0.23	0.55	0.07	
	TS125/220	-	0.40	0.95	0.07	
	TS220/220	-	0.73	1.1	0.09	
	TS220/310	-	1.3	2.1	0.09	
	TS260/350	-	3.8	5.6	0.12	
Two-axis specification	CT 55/ 55	X-axis	0.01	-	0.03	
		Y-axis	0.01	-		
	CT 75/ 75	X-axis	0.01	-	0.07	
		Y-axis	0.01	-		
	CT125/125	X-axis	0.20	0.28	0.85	0.07
		Y-axis	0.20	0.23	0.55	
	CT220/220	X-axis	-	0.85	1.9	0.09
		Y-axis	-	0.73	1.1	
	CT260/350	X-axis	-	4.6	6.8	0.12
		Y-axis	-	3.8	5.6	
CT350/350	X-axis	-	4.9	8.0	0.12	
	Y-axis	-	4.6	5.9		

## Mounting

For the processing accuracy of the Precision Positioning Table mounting surface and the tightening torque of the fixing screws, see page III-36.

# Sensor Specification

Table 9.1 Sensor timing chart for TS (single-axis specification)

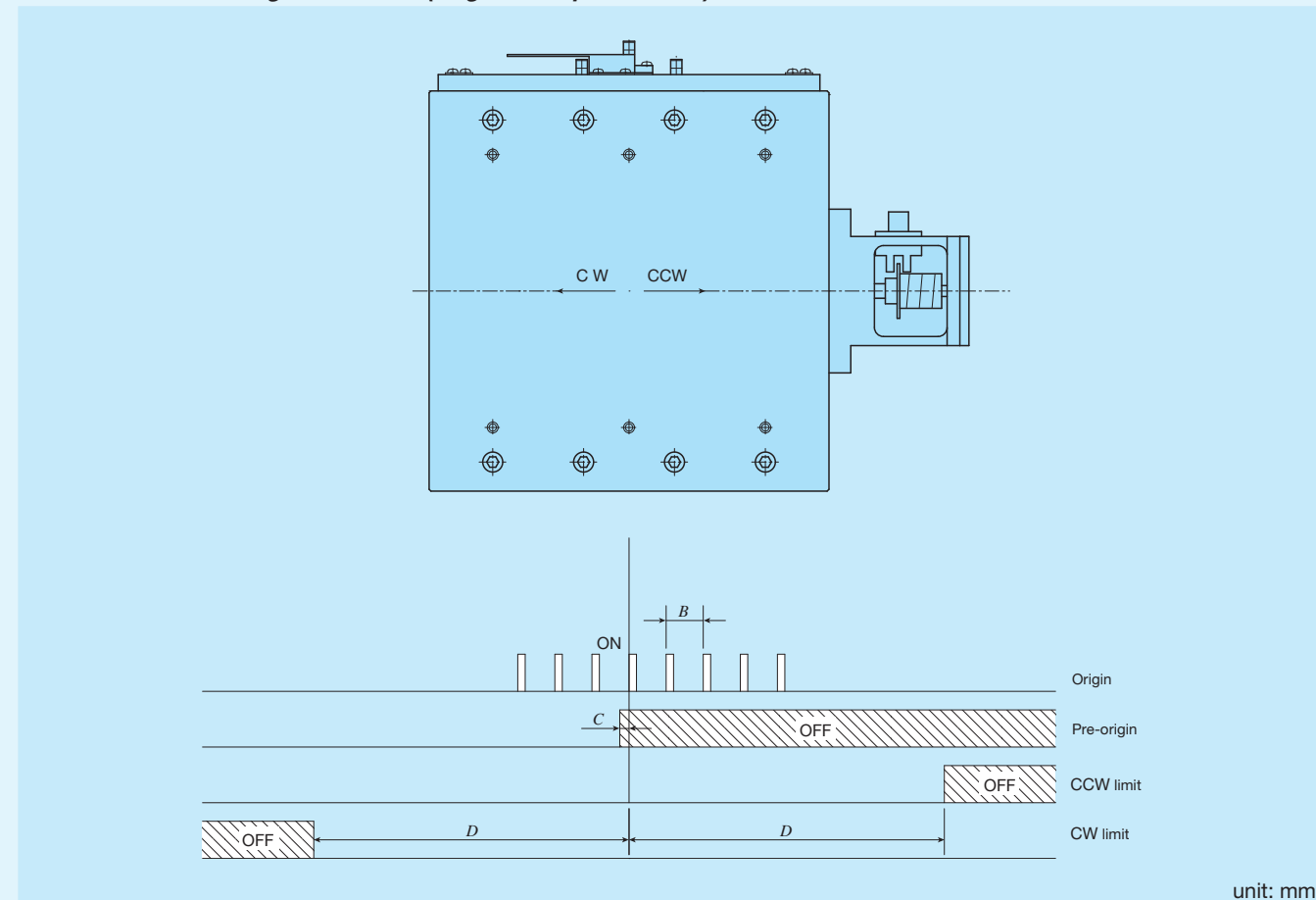

Identification number	Ball screw lead	B	C	D
TS 55/ 55	1	1	0.7	7.5
TS 75/ 75	1	1	0.7	12.5
TS125/125	1	1	0.7	25
	2	2	1.5	
TS125/220	2	2	1.5	60
	5	5	3	
TS220/220	2	2	1.5	60
	5	5	3	
TS220/310	2	2	1.5	90
	5	5	3	
TS260/350	2	2	1.5	125
	5	5	3	

- Remarks
1. Mounting a sensor is specified using the corresponding identification number.
  2. For the specifications of respective sensors, please see the section of sensor specification in General Explanation.
  3. When selecting an AC servomotor attachment, an origin sensor is not provided. Please use the C-phase or Z-phase of the encoder.
  4. Positions for mounting sensors vary depending on the identification numbers. For detailed information, please see the dimension tables of respective identification numbers.

Table 9.2 Sensor timing chart for CT (two-axis specification)

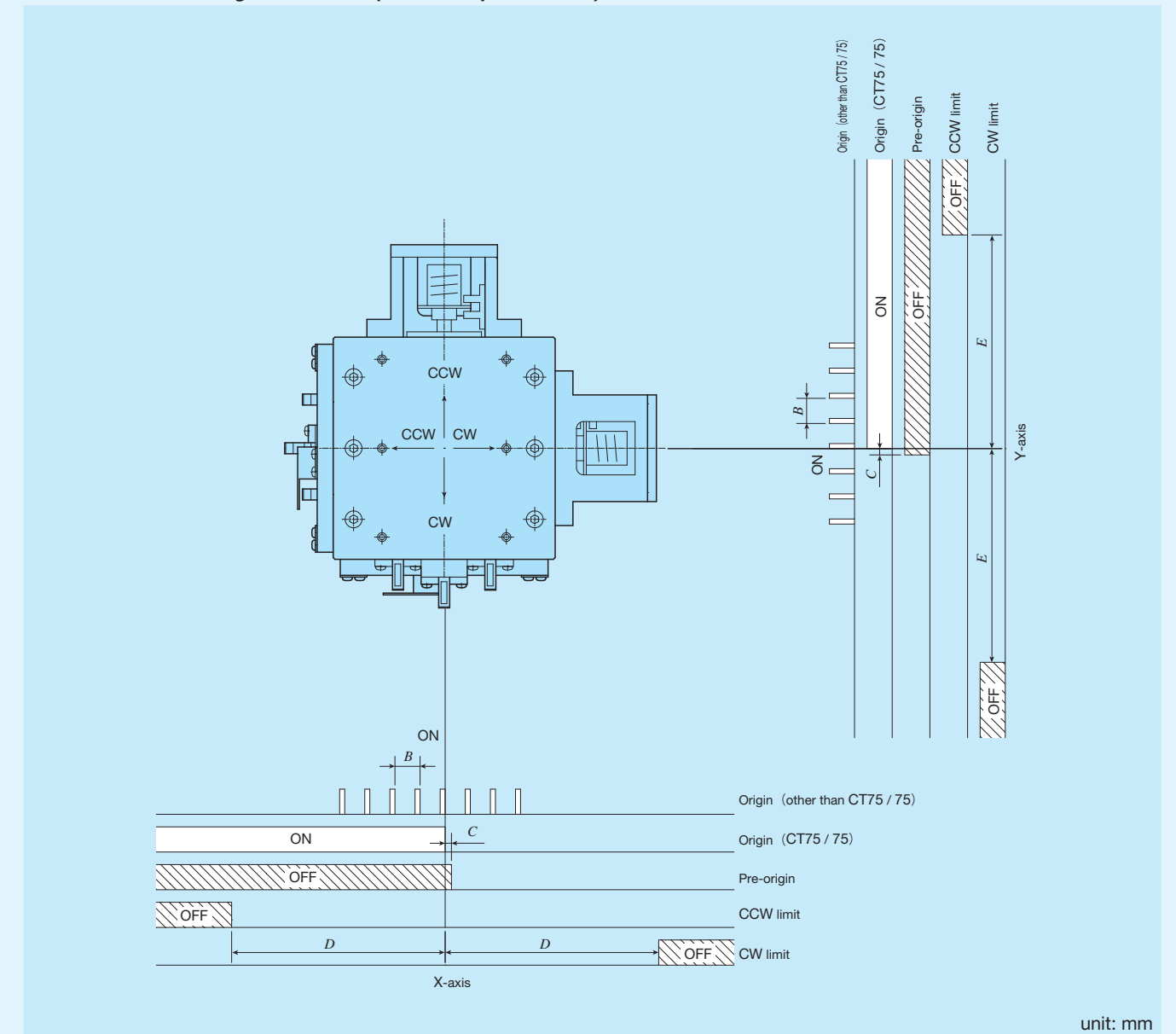

Identification number	Ball screw lead	B	C	D	E
CT 55/ 55	1	1	0.7	7.5	7.5
CT 75/ 75	1	—	0.7	12.5	12.5
CT125/125	1	1	0.7	25	25
	2	2	1.5		
CT220/220	2	2	1.5	60	60
	5	5	3		
CT260/350	2	2	1.5	75	125
	5	5	3		
CT350/350	2	2	1.5	125	125
	5	5	3		

- Remarks
1. Mounting a sensor is specified using the corresponding identification number.
  2. For the specifications of respective sensors, please see the section of sensor specification in General Explanation.
  3. When selecting an AC servomotor attachment, an origin sensor is not provided. Please use the C-phase or Z-phase of the encoder.
  4. Positions for mounting sensors vary depending on the identification numbers. For detailed information, please see the dimension tables of respective identification numbers.

# Dimensions of Motor Attachment

## TS55/55, CT55/55

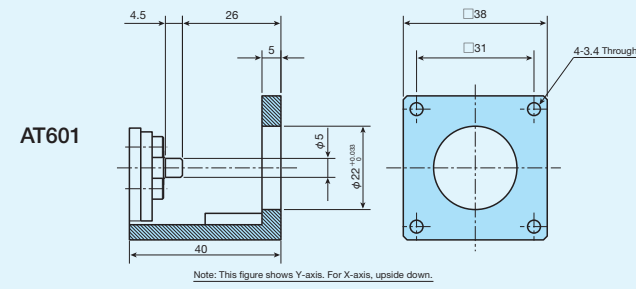

## TS75/75, CT75/75

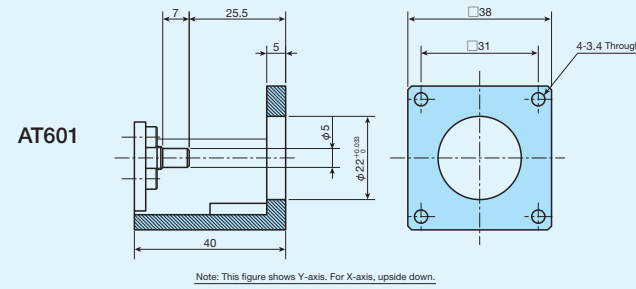

## TS125/125, CT125/125

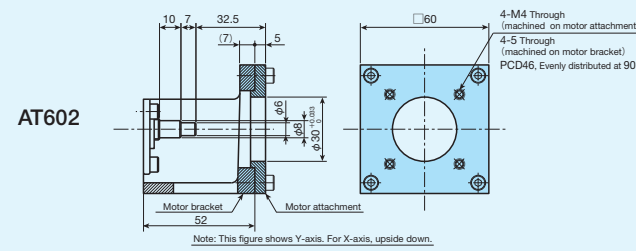

## TS125/220

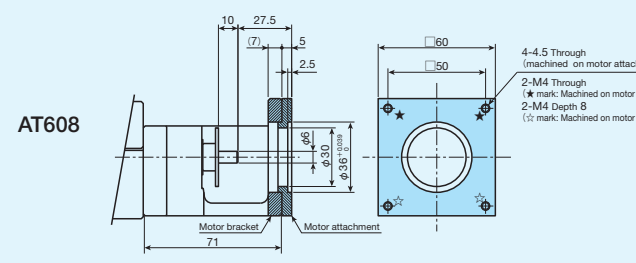
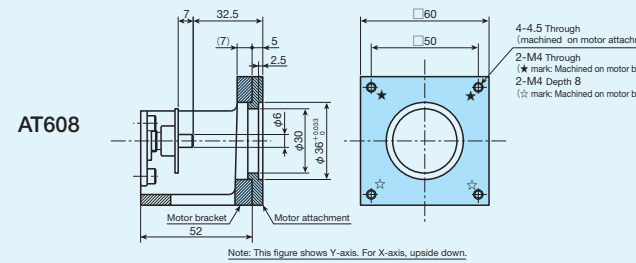
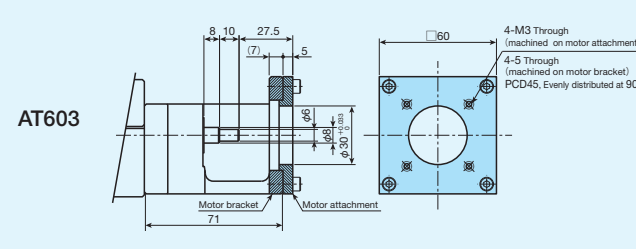
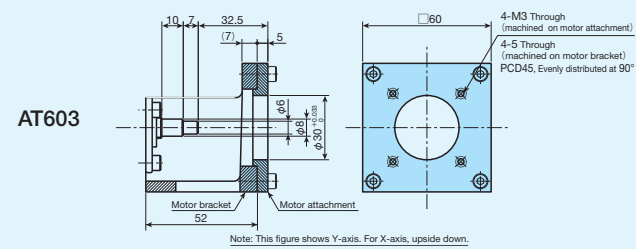
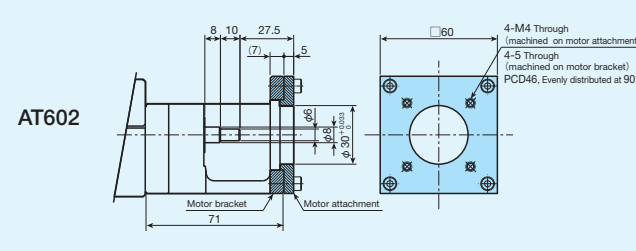

## TS220/220, CT220/220

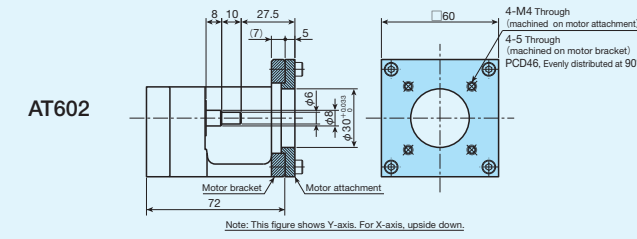

## TS220/310

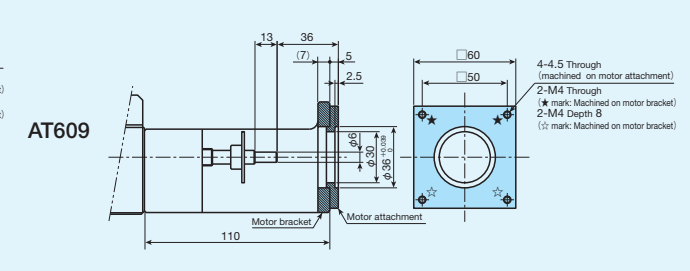
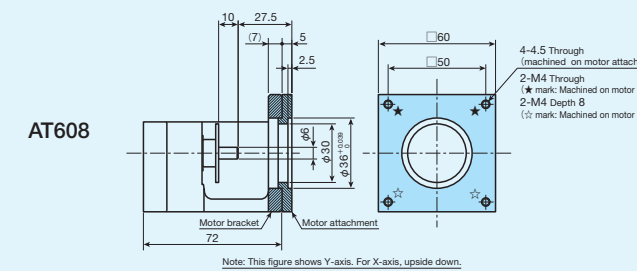
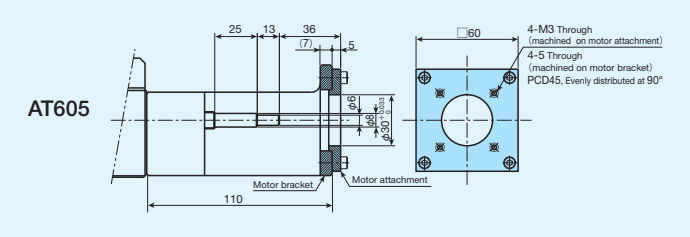
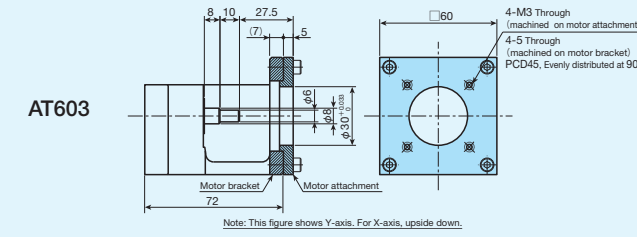
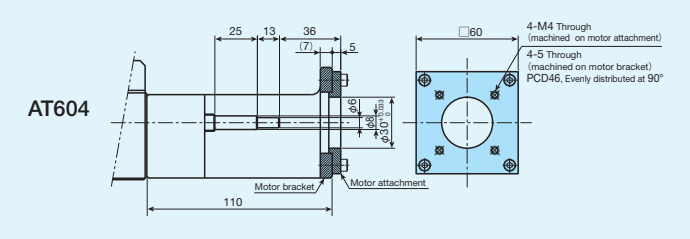

## TS260/350

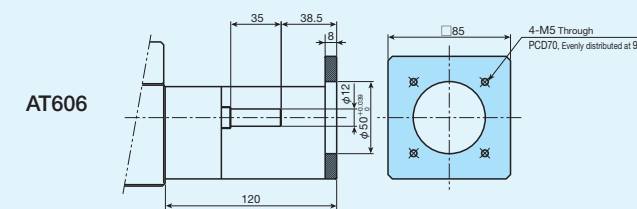

## CT260/350

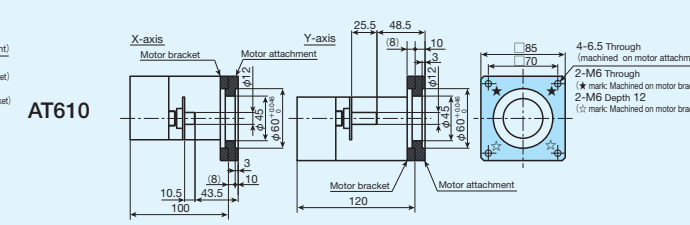
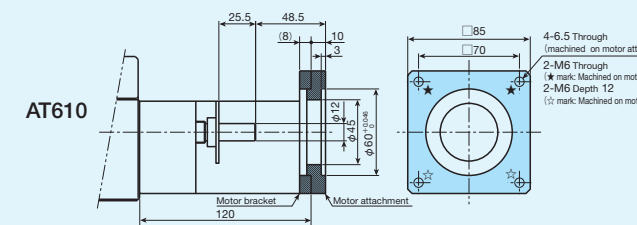
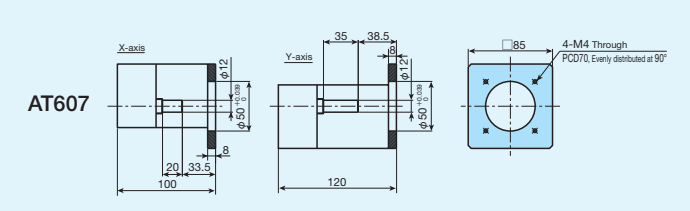
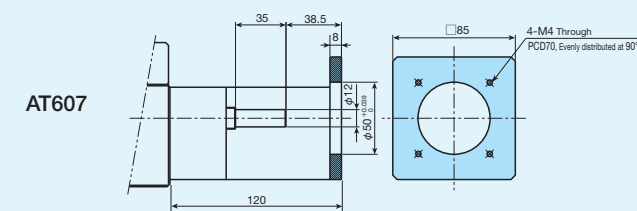
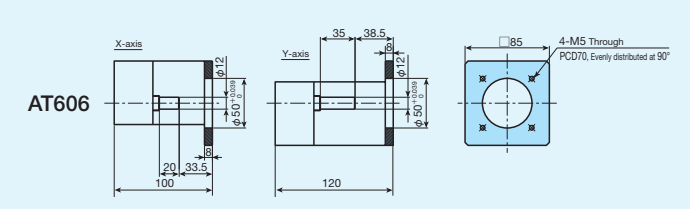

CT350/350

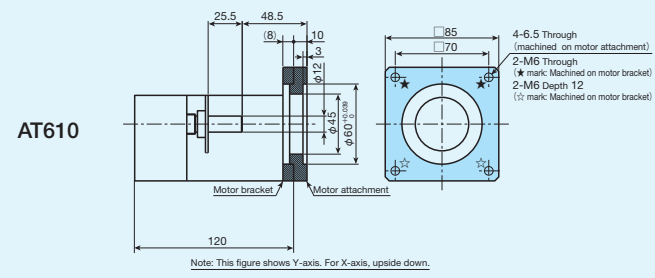
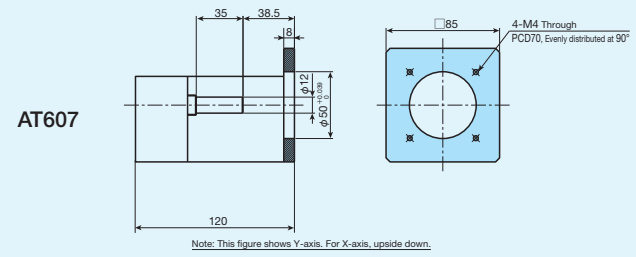
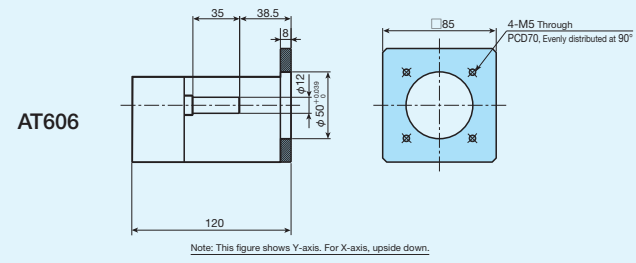

TS55/55

● Specification without sensor

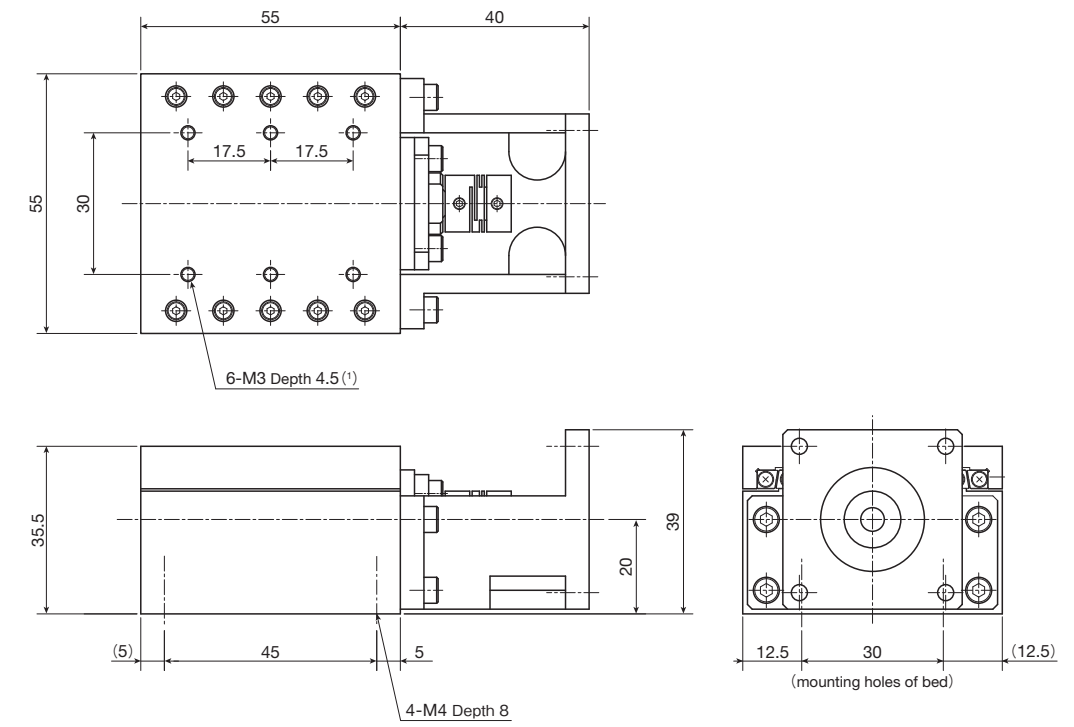

● Specification with sensor

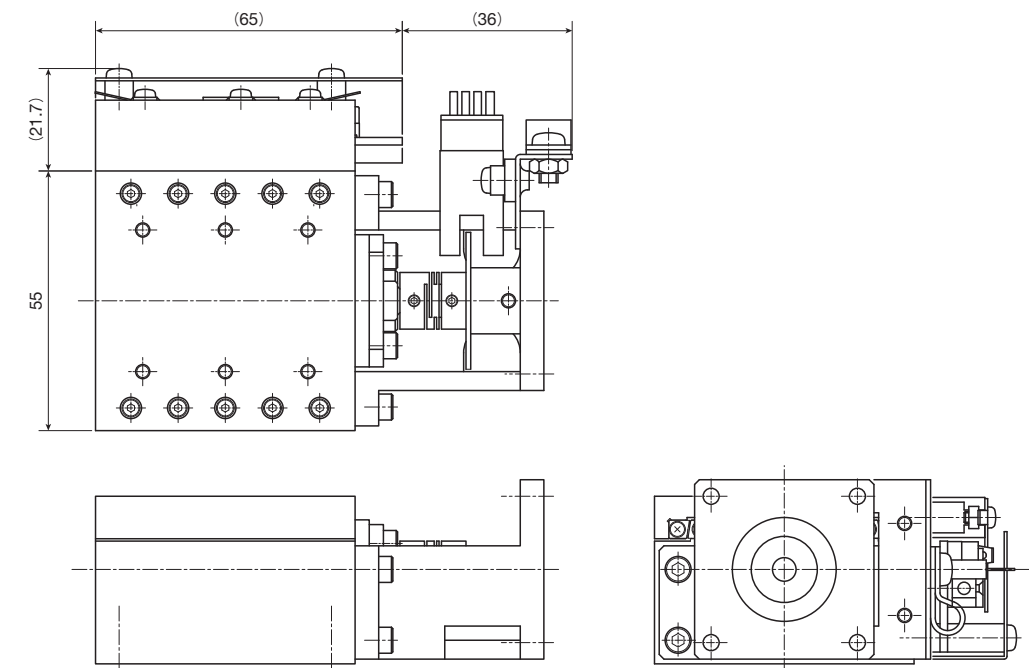

Stroke length: 15mm  
Reference mass<sup>(2)</sup>: 0.8kg

Notes <sup>(1)</sup> Too deep insertion depth of the mounting bolt may affect the running performance of the slide table, so never insert a bolt longer than the depth of the through hole.

<sup>(2)</sup> Mass of the sensor is not included.



# IKO Precision Positioning Table TS / CT

## TS75/75

### ● Specification without sensor

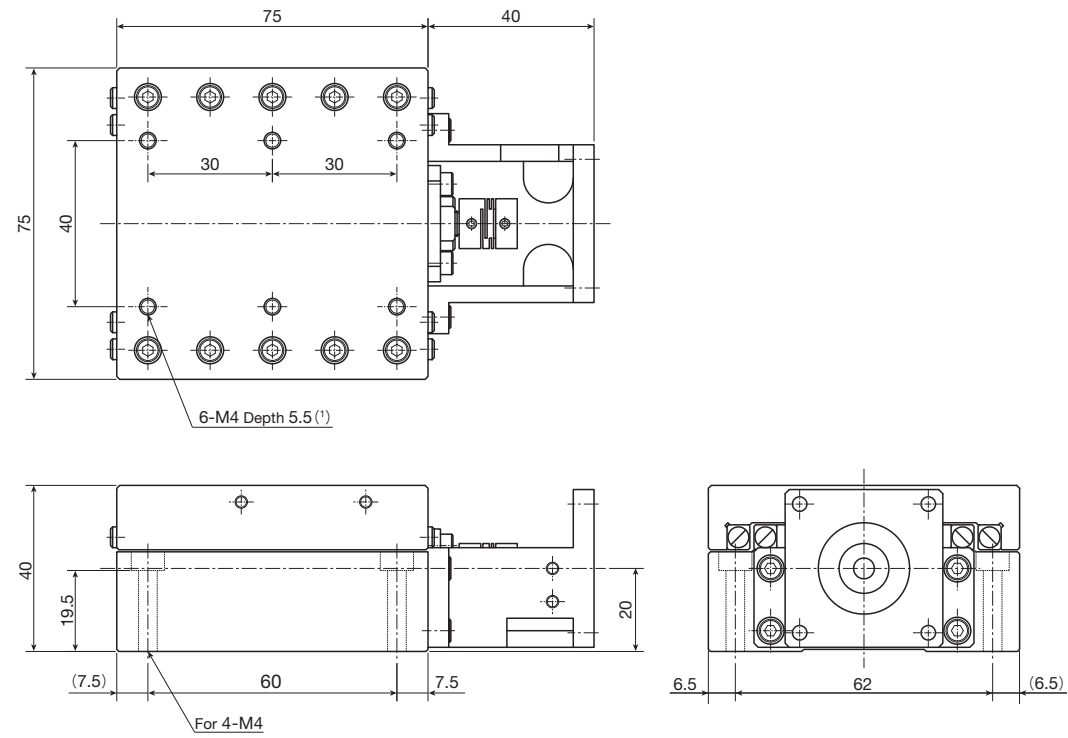

### ● Specification with sensor

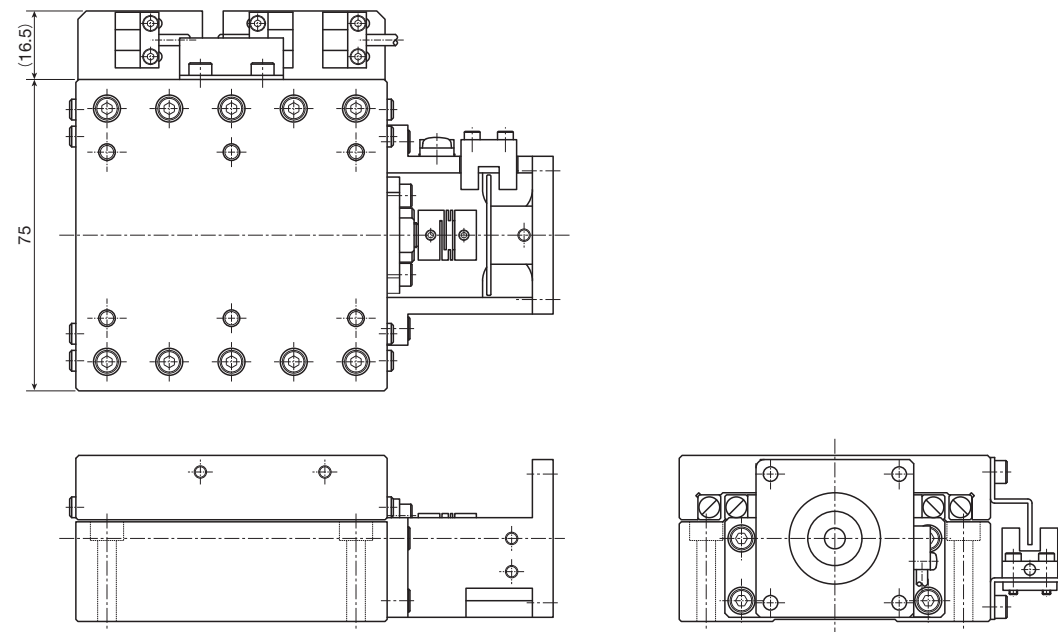

Notes (1) Too deep insertion depth of the mounting bolt may affect the running performance of the slide table, so never insert a bolt longer than the depth of the through hole.  
 (2) Mass of the sensor is not included.

## TS125/125, TS220/220

### ● Specification without sensor

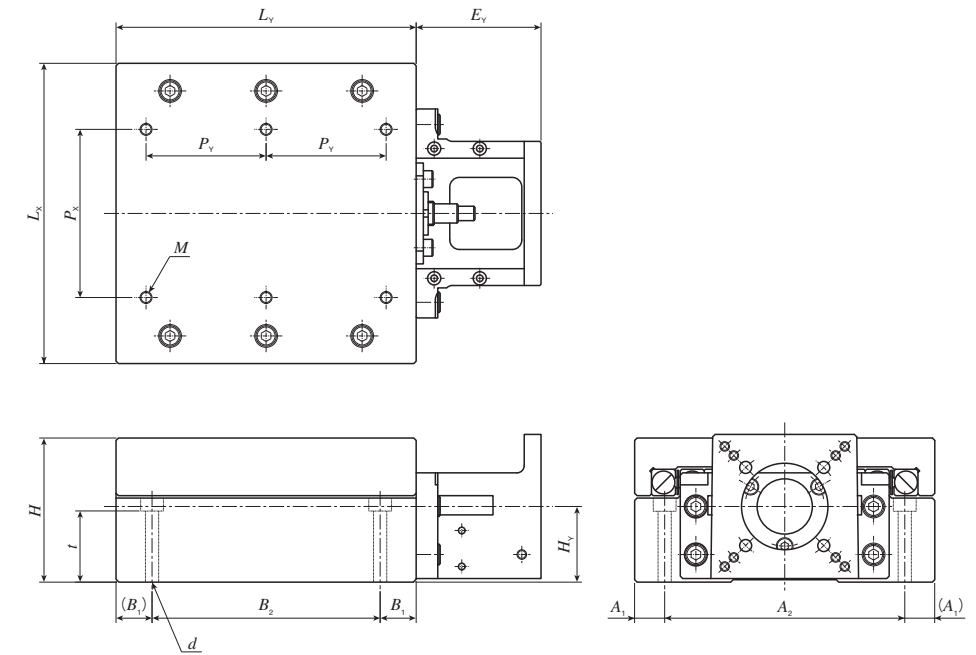

### ● Specification with sensor

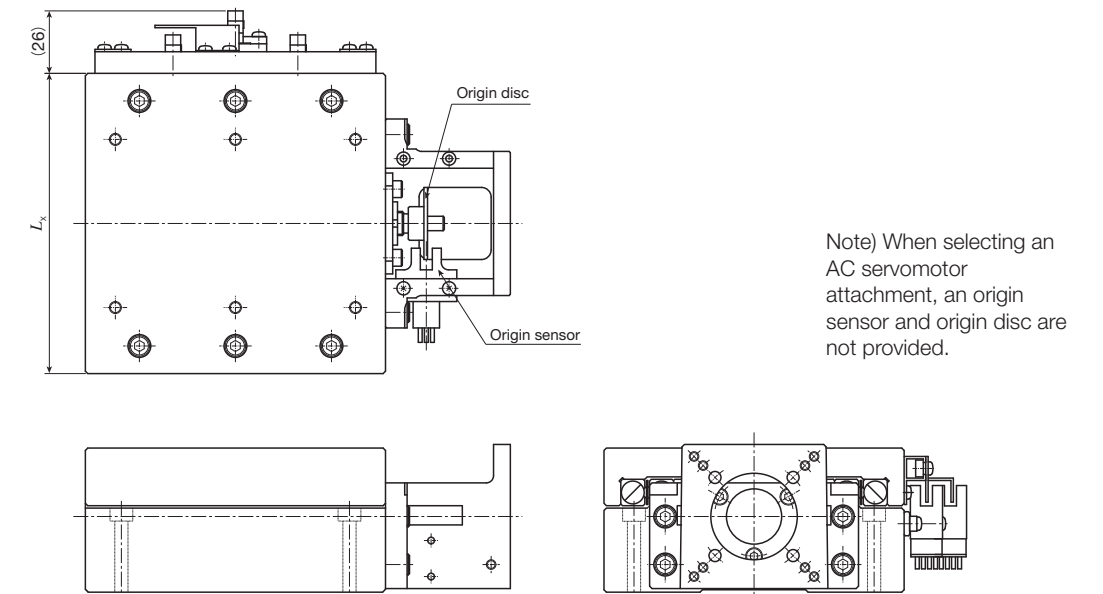

unit: mm

Identification number	Dimensions of table			Stroke length	Ey	Height of shaft center	
	Lx	Ly	H			Hs	Ht
TS125/125 <sup>(1)</sup>	125	125	60	50	52	31.5	
TS220/220	220	220	65	120	72	33.5	

Identification number	Mounting bolt			Bed mounting-related dimensions						Reference mass <sup>(2)</sup> kg
	M <sup>(3)</sup>	Px	Py	d	t	A1	A2	B1	B2	
TS125/125 <sup>(1)</sup>	6-M5 depth 10	70	50	For 4-M5	29.6	12.5	100	15	95	7.5
TS220/220	6-M6 depth 12	150	75	For 4-M6	27.5	20	180	20	180	16.0

Notes (1) The motor bracket is positioned 1.5mm higher than the upper surface of the table.  
 (2) Mass of the sensor is not included.  
 (3) Too deep insertion depth of the mounting bolt may affect the running performance of the slide table, so never insert a bolt longer than the depth of the through hole.

# IKO Precision Positioning Table TS / CT

TS125/220, TS220/310, TS260/350

## ● Specification without sensor

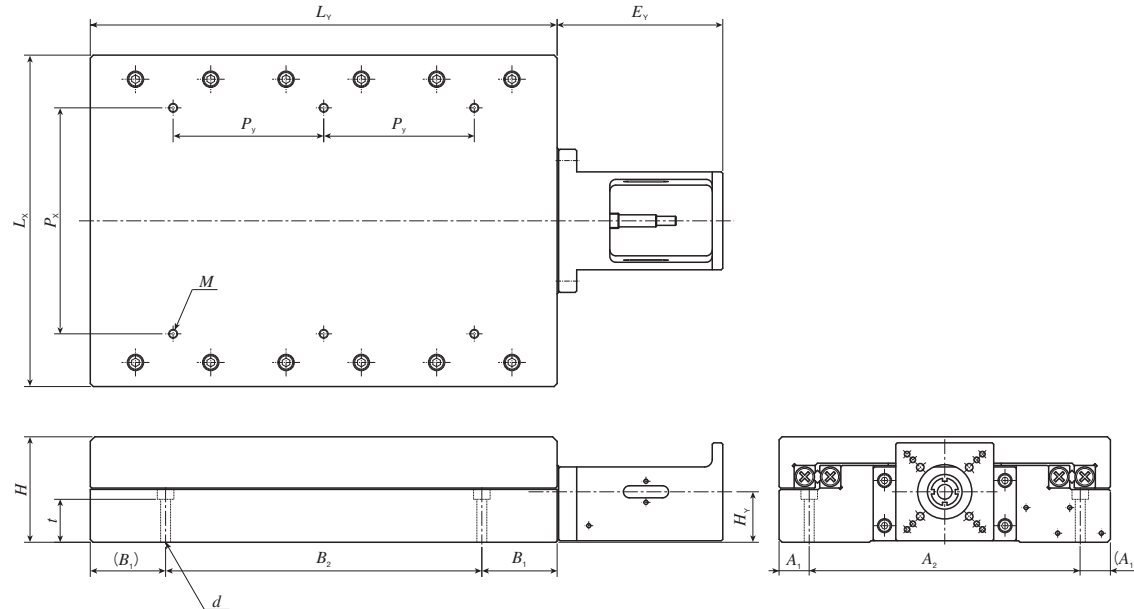

## ● Specification with sensor

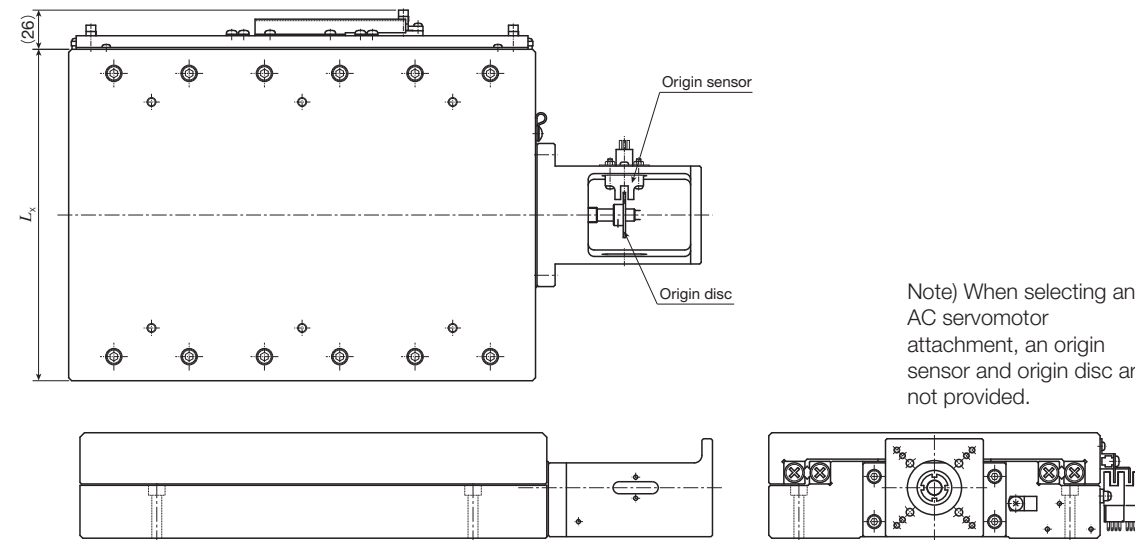

Note) When selecting an AC servomotor attachment, an origin sensor and origin disc are not provided.

unit: mm

Identification number	Dimensions of table			Stroke length	$E_y$	Height of shaft center $H_y$
	$L_x$	$L_y$	$H$			
TS125/220 <sup>(1)</sup>	125	220	60	120	71	31.5
TS220/310	220	310	70	180	110	33.5
TS260/350	260	350	100	250	120	47.5

Identification number	Mounting bolt			Bed mounting-related dimensions						Reference mass <sup>(2)</sup> kg
	$M^{(3)}$	$P_x$	$P_y$	$d$	$t$	$A_1$	$A_2$	$B_1$	$B_2$	
TS125/220 <sup>(1)</sup>	6-M5 depth 10	70	75	For 4-M5	29.6	12.5	100	20	180	11
TS220/310	6-M6 depth 12	150	100	For 4-M6	28.5	20	180	50	210	27
TS260/350	6-M6 depth 12	150	125	For 4-M8	45.4	22.5	215	50	250	48

Notes <sup>(1)</sup> The motor bracket is positioned 1.5mm higher than the upper surface of the table.  
<sup>(2)</sup> Mass of the sensor is not included.  
<sup>(3)</sup> Too deep insertion depth of the mounting bolt may affect the running performance of the slide table, so never insert a bolt longer than the depth of the through hole.

CT55/55

## ● Specification without sensor

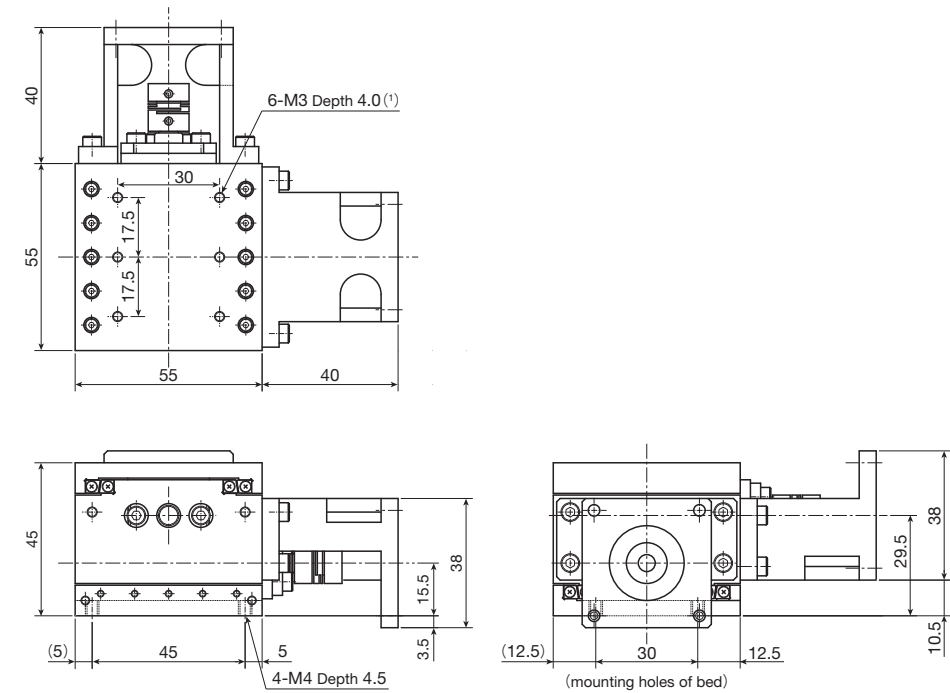

## ● Specification with sensor

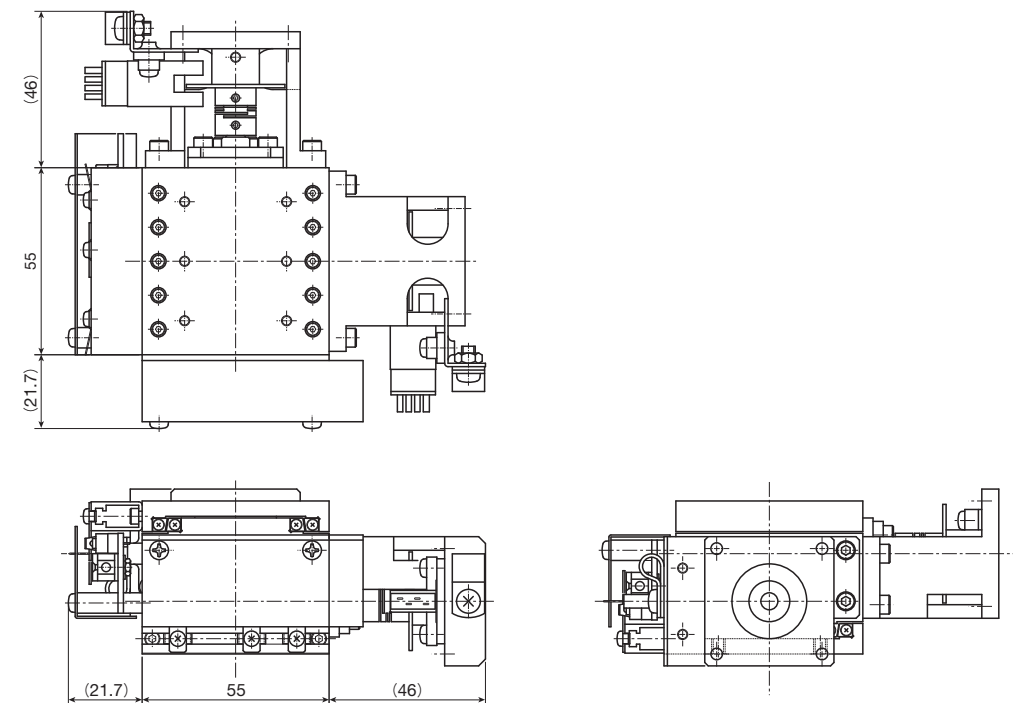

X- and Y-axis stroke length: 15mm  
 Reference mass<sup>(2)</sup>: 1.7kg

Notes <sup>(1)</sup> Too deep insertion depth of the mounting bolt may affect the running performance of the slide table, so never insert a bolt longer than the depth of the through hole.  
<sup>(2)</sup> Mass of the sensor is not included.

# IKO Precision Positioning Table TS / CT

## CT75/75

### ● Specification without sensor

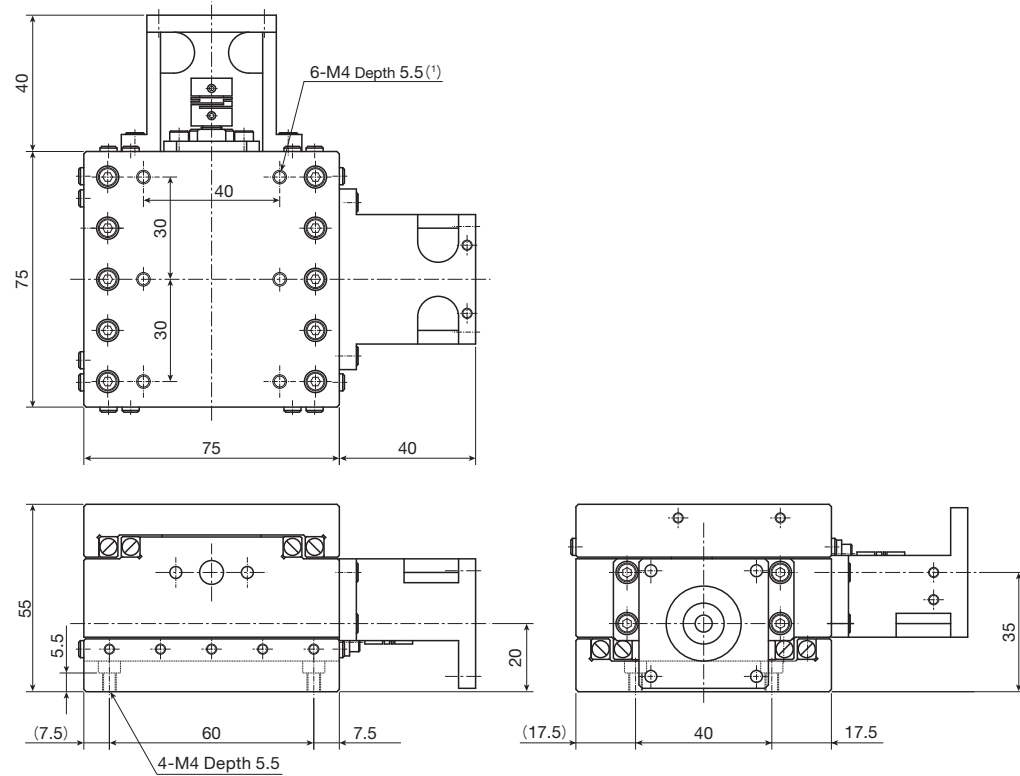

### ● Specification with sensor

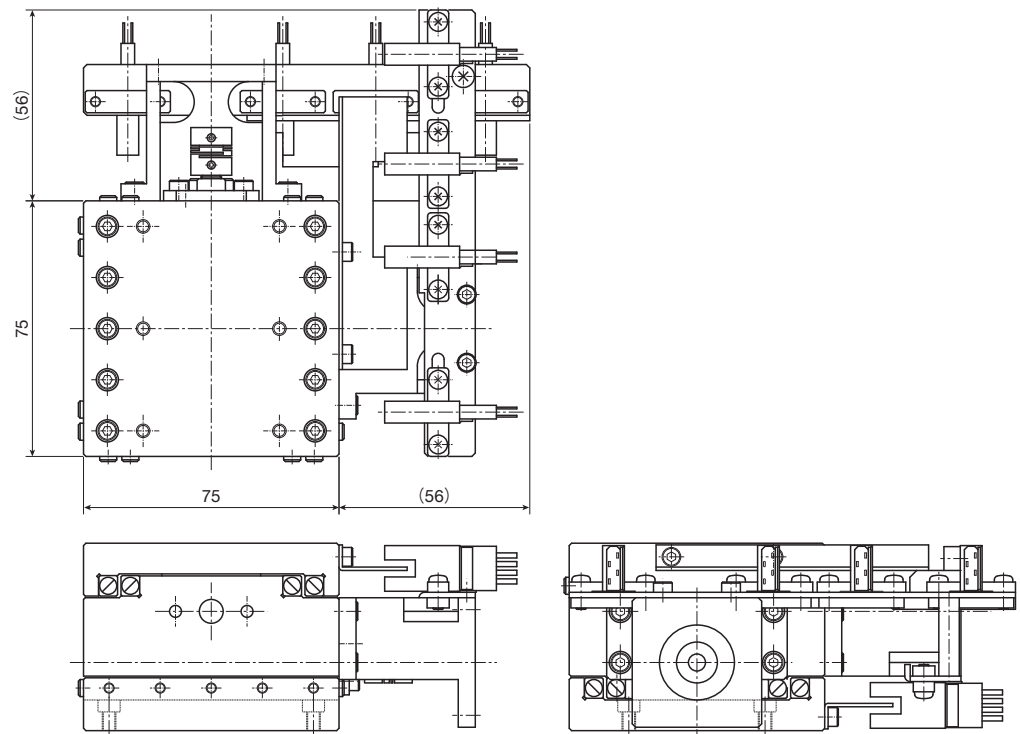

X- and Y-axis stroke length: 25mm  
Reference mass<sup>(2)</sup>: 2.0kg

Notes <sup>(1)</sup> Too deep insertion depth of the mounting bolt may affect the running performance of the slide table, so never insert a bolt longer than the depth of the through hole.  
<sup>(2)</sup> Mass of the sensor is not included.

## CT125/125

### ● Specification without sensor

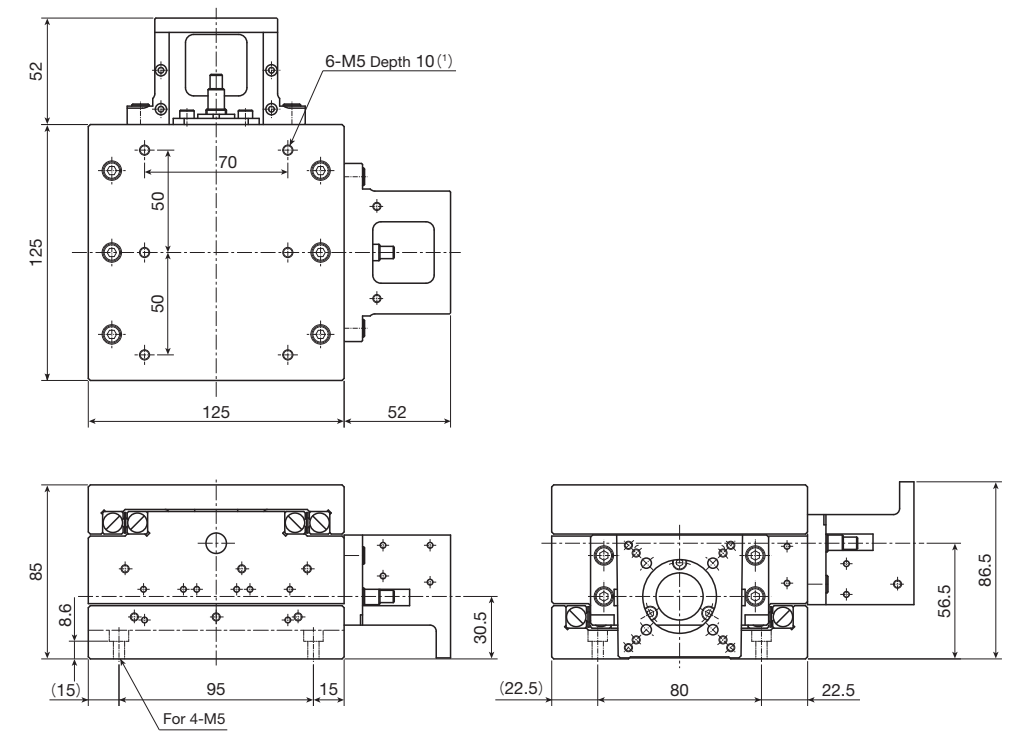

### ● Specification with sensor

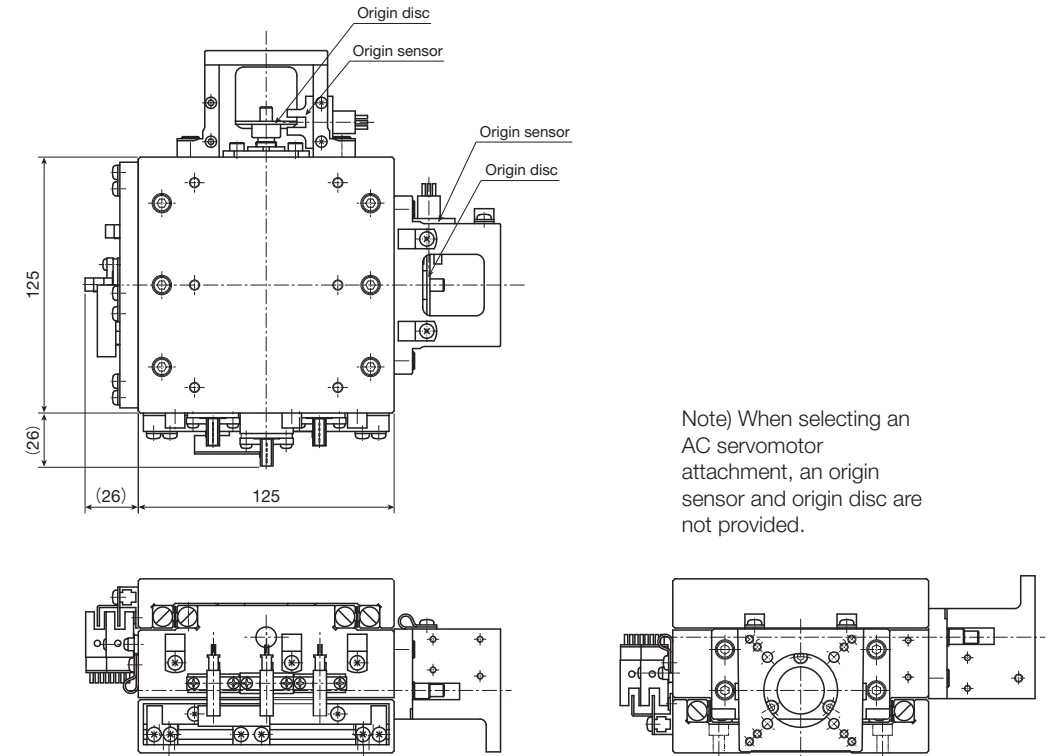

Note) When selecting an AC servomotor attachment, an origin sensor and origin disc are not provided.

X- and Y-axis stroke length: 50mm  
Reference mass<sup>(2)</sup>: 1.7kg

Notes <sup>(1)</sup> Too deep insertion depth of the mounting bolt may affect the running performance of the slide table, so never insert a bolt longer than the depth of the through hole.  
<sup>(2)</sup> Mass of the sensor is not included.

# IKO Precision Positioning Table TS / CT

CT220/220, CT260/350, CT350/350

## ● Specification without sensor

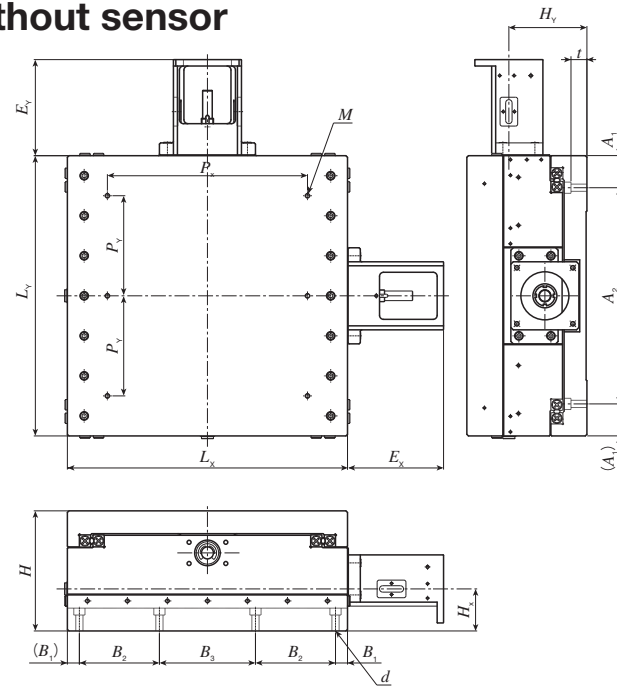

## ● Specification with sensor

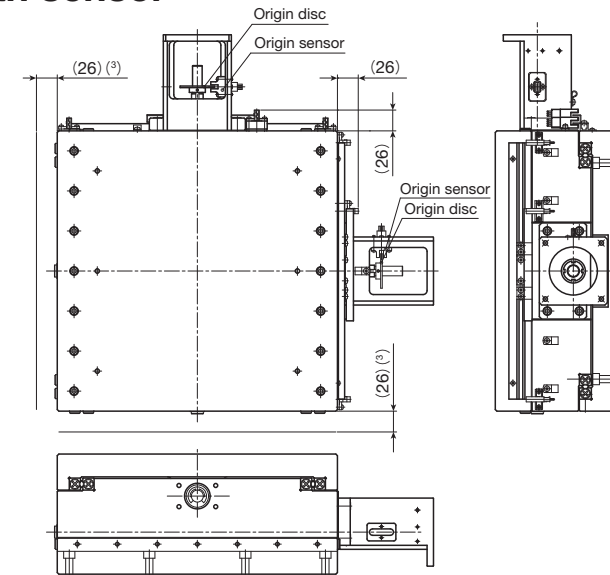

Note) When selecting an AC servomotor attachment, an origin sensor and origin disc are not provided.

unit: mm

Identification number	Dimensions of table			Stroke length		$E_x$	$E_y$	Height of shaft center	
	$L_x$	$L_y$	$H$	X-axis	Y-axis			$H_x$	$H_y$
CT220/220	220	220	100	120	120	72	72	31.5	68.5
CT260/350	260	350	150	150	250	100	120	52.5	97.5
CT350/350	350	350	150	250	250	120	120	52.5	97.5

Identification number	Mounting bolt			Bed mounting-related dimensions							Reference mass <sup>(2)</sup> kg
	$M^{(1)}$	$P_x$	$P_y$	$d$	$t$	$A_1$	$A_2$	$B_1$	$B_2$	$B_3$	
CT220/220	6-M6 depth 12	150	75	For 8-M6	7.5	30	160	15	40	110	20
CT260/350	6-M6 depth 12	150	125	For 8-M8	20	40	270	15	55	120	66
CT350/350	6-M6 depth 12	250	125	For 8-M8	20	40	270	15	100	120	77

Notes <sup>(1)</sup> Too deep insertion depth of the mounting bolt may affect the running performance of the slide table, so never insert a bolt longer than the depth of the through hole.

<sup>(2)</sup> Mass of the sensor is not included.

<sup>(3)</sup> Applicable to CT220/220. This shows the dimension when the sensor is attached.

## ● Option base dimensions for TS55/55 and CT55/55

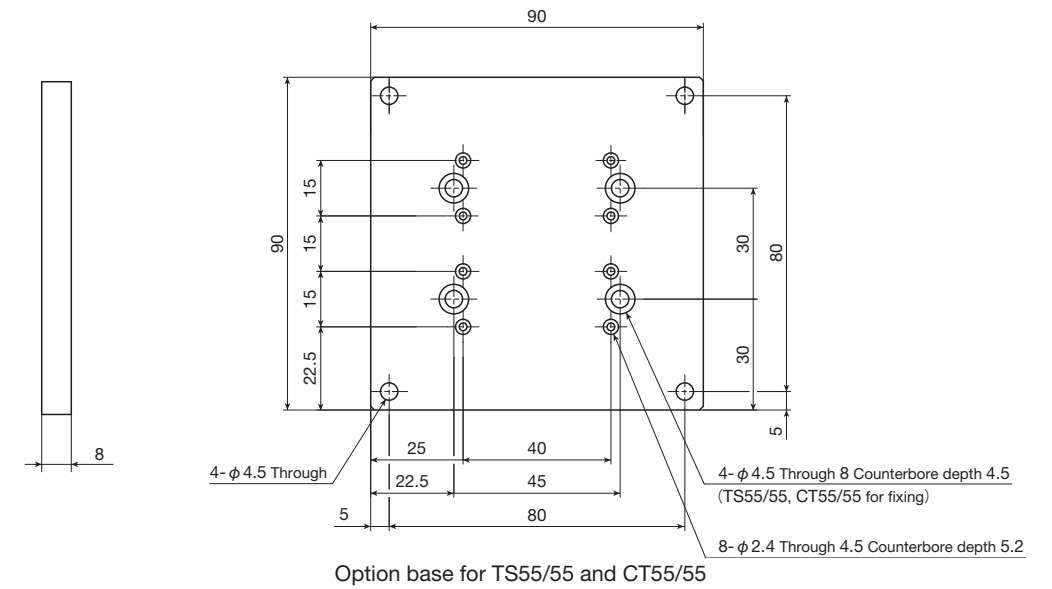

Option base for TS55/55 and CT55/55