

TX...M
CTX...M

TX...M • CTX...M

TX...M

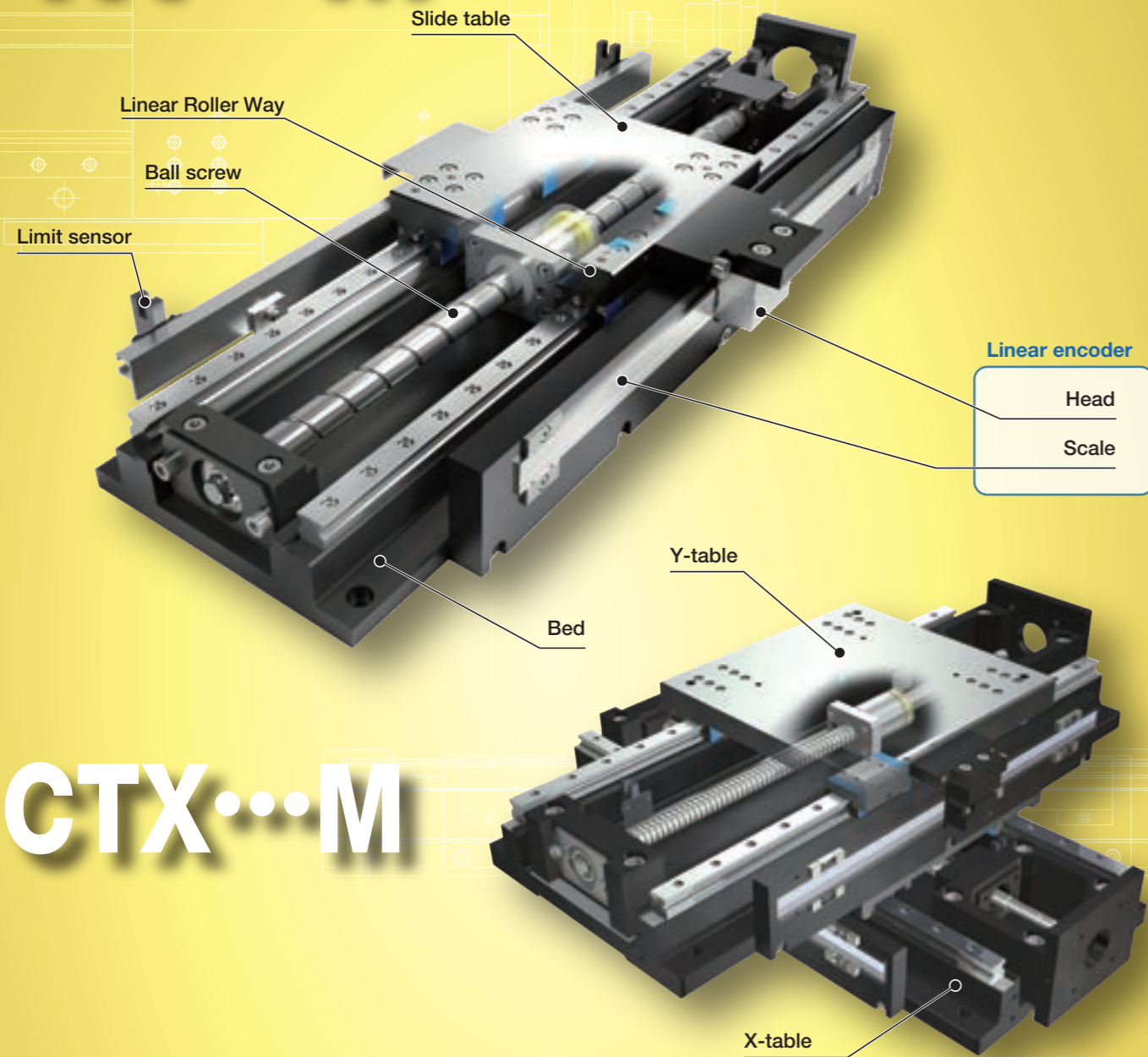
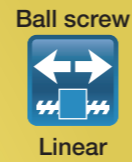

CTX...M

Major product specifications

Driving method	Precision ball screw
Linear motion rolling guide	Linear Roller Way (roller type)
Built-in lubrication part	Lubrication part "C-Lube" is built-in
Material of table and bed	Cast iron
Sensor	Provided as standard

Accuracy

Positioning repeatability	±0.0005~0.0010
Positioning accuracy	0.003~0.020
Lost motion	0.001
Parallelism in table motion A	0.005~0.011
Parallelism in table motion B	-
Attitude accuracy	5~11sec
Straightness	0.003~0.008
Backlash	-

unit: mm

Points

1 Ultimate high accuracy table of rolling guide type

High precision, high rigidity Precision Positioning Table LH based positioning table with positioning accuracy almost the same as Air Stage with ultimate rolling guide C-Lube Linear Roller Way Super MX incorporated and by a thorough investigation of the accuracy of each part.

2 High positioning accuracy and resolution performance realized with an onboard super high accuracy linear encoder

Fully closed loop control is configured and the positioning accuracy of the entire stroke is guaranteed with a direct feed back of positional information from a super high accuracy linear encoder.

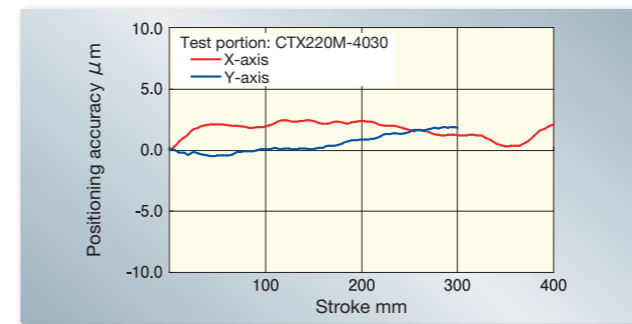

3 Ultimate high running performance produced by adopting roller type linear motion rolling guide

Ultimate running accuracy is achieved since components processed and assembled with high accuracy are combined with C-Lube Linear Roller Way Super MX that exhibits the highest level of running performance with a rolling guide.

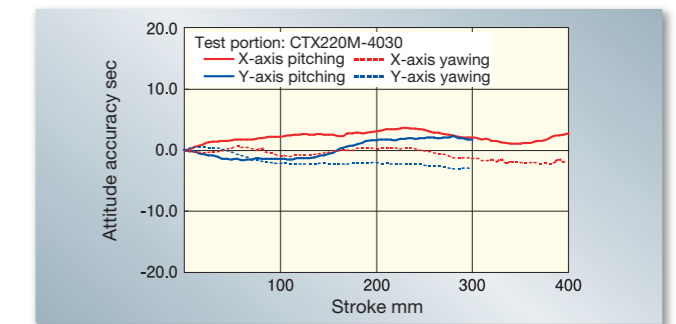

4 Absolute linear encoder can be selected

For the linear encoder, select either absolute type or incremental type. Absolute types do not require returning to origin and can handle both high resolution and high-speed travel.

5 Simple system configuration

The simple system configuration reduces space and cost reduction since an air supply device, such as an Air Stage, is not required.

Variation

Shape	Model and size	Table width (mm)	Stroke length (mm)								
			100	150	200	250	300	400	500	600	800
	TX120M	120	☆	☆	☆	☆	☆	-	-	-	-
	TX220M	220	-	☆	☆	☆	☆	☆	-	-	-
	TX320M	320	-	-	-	-	☆	☆	☆	-	-
	TX420M	420	-	-	-	-	-	-	☆	☆	☆

Identification Number

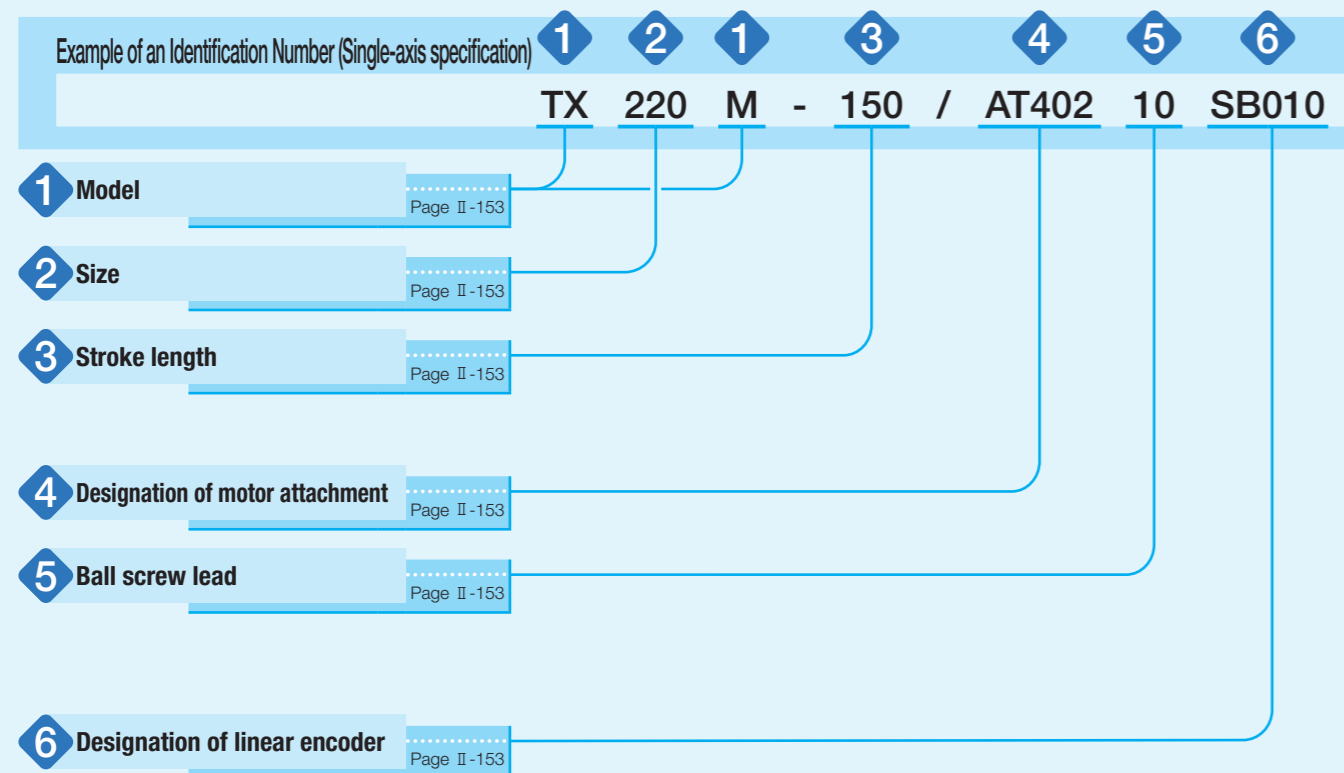

Identification Number and Specification

1 Model	TX...M: Super Precision Positioning Table TX (single-axis specification)
2 Size	Size indicates table width. Select a size from the list of Table 1.
3 Stroke length	Select a stroke length from the list of Table 1.
4 Designation of motor attachment	As for a motor attachment, select it from the list of Table 3. <ul style="list-style-type: none"> Motor should be prepared by customer. Please specify motor attachment applicable to motor for use. A coupling shown in Table 4 is mounted on the main body before shipment. However, the final position adjustment should be made by customer since it is only temporarily fixed.
5 Ball screw lead	5: Lead 5mm 10: Lead 10mm
6 Designation of linear encoder	Select the linear encoder from Table 5. Without a linear encoder, select the S0000 code. <ul style="list-style-type: none"> When specifying the attachment for a stepper motor, set S0000. If using a motor not shown in Table 3, please contact IKO.

Identification Number

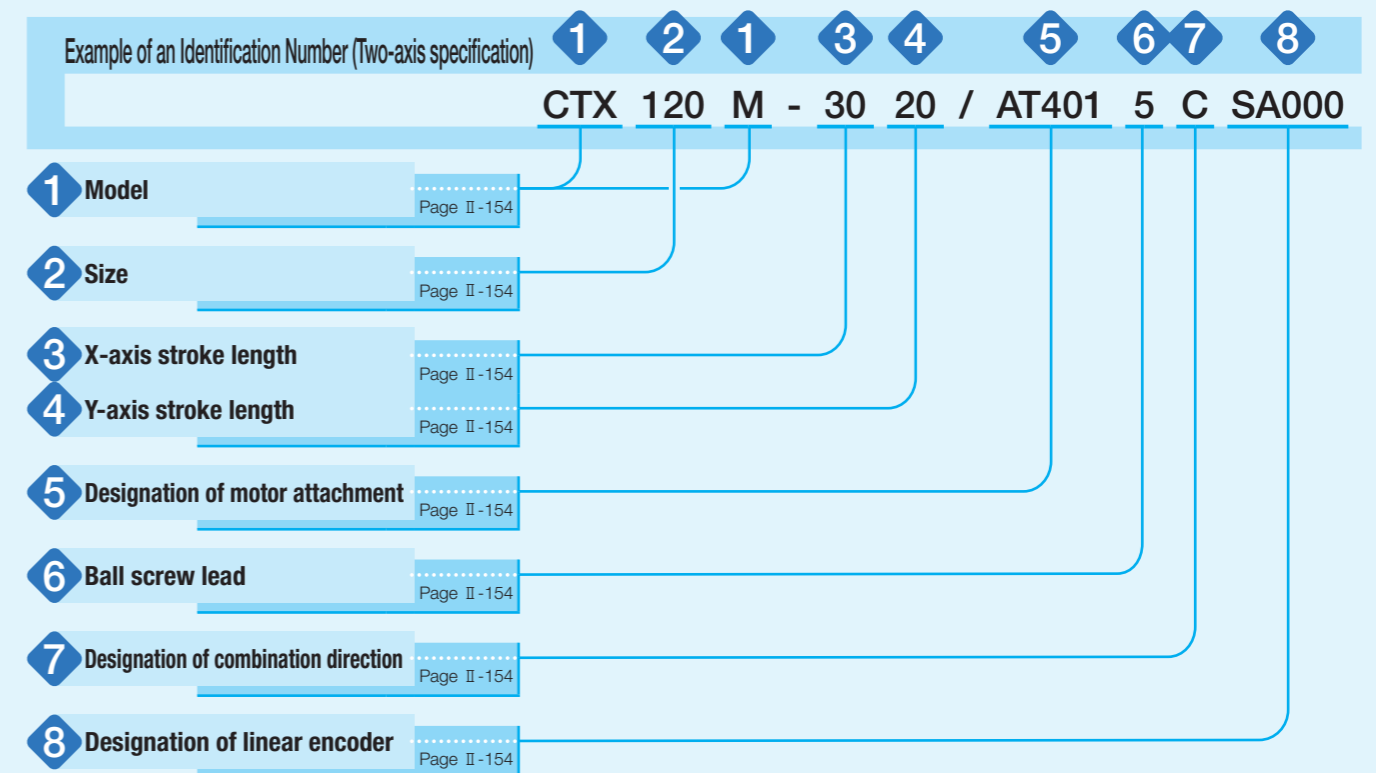

Identification Number and Specification

1 Model	CTX...M: Super Precision Positioning Table TX (two-axis specification)
2 Size	Size indicates table width. Select a size from the list of Table 2. Tables of different sizes can also be combined.
3 X-axis stroke length	Select a stroke length from the list of Table 2.
4 Y-axis stroke length	Stroke lengths of respective axes are displayed in cm. Different stroke lengths can be specified for X- and Y-axes.
5 Designation of motor attachment	As for a motor attachment, select it from the list of Table 3. <ul style="list-style-type: none"> Motor should be prepared by customer. Please specify motor attachment applicable to motor for use. A coupling shown in Table 4 is mounted on the main body before shipment. However, the final position adjustment should be made by customer since it is only temporarily fixed.
6 Ball screw lead	5: Lead 5mm 10: Lead 10mm
7 Designation of combination direction	No symbol : Standard configuration C : Reverse configuration Standard configuration: A direction under the condition where X-axis motor side is placed at the front and Y-axis motor side is placed on the right side respectively. Reverse configuration: A direction under the condition where X-axis motor side is placed at the front and Y-axis motor side is placed on the left side respectively. Specify "No symbol" if 200mm is selected for Y-axis stroke length for CTX220M.
8 Designation of linear encoder	Select the linear encoder from Table 5. Without a linear encoder, select the S0000 code. <ul style="list-style-type: none"> When specifying the attachment for a stepper motor, set S0000. If using a motor not shown in Table 3, please contact IKO.

Identification Number and Specification

Table 1 Sizes and stroke lengths of TX

Model and size	Table width mm	Stroke length mm
TX120M	120	100, 150, 200, 250, 300
TX220M	220	150, 200, 250, 300, 400
TX320M	320	300, 400, 500
TX420M	420	500, 600, 800

Table 2 Sizes and stroke lengths of CTX

Model and size	Table width mm	Stroke length mm	
		X-axis	Y-axis
CTX120M	120	100	100
		200	100
		200	200
		300	200
CTX220M	220	200	200
		300	200
		400	300

Table 3 Application of motor attachment

Type	Models of motor to be used				Flange size mm	Motor attachment			
	Manufacturer	Series	Model	Rated output W		TX120M CTX120M	TX220M CTX220M	TX320M	TX420M
AC servo motor	YASKAWA ELECTRIC CORPORATION	Σ-7	SGM7A-02A	200	□60	AT401	—	—	—
			SGM7A-04A	400		—	AT402	—	—
			SGM7A-06A	600		—	—	AT403	—
			SGM7A-08A	750		—	—	—	AT404
	Mitsubishi Electric Corporation	J4 J5	HG-KR23/HK-KT23W	200	□60	AT401	—	—	—
			HG-KR43/HK-KT43W	400		—	AT402	AT403	—
			HG-KR43/HK-KT7M3W	750		—	—	—	AT404
	Panasonic Corporation	MINAS A6	MSMF02	200	□60	AT405	—	—	—
MSMF04			400	—		AT406	AT407	—	
MSMF08			750	—		—	—	AT408	
Stepper motor	ORIENTAL MOTOR Co., Ltd.	α step	ARM66	□60	AT409	—	—	—	
			ARM69		AT409	—	—	—	
			ARM98		—	AT411	AT412	—	
			ARM911		—	AT411	AT412	—	
			RKS56		□60	AT409	—	—	—
	RKS59	□85	—	AT411	AT412	—			

Remark: For detailed motor specifications, please see respective motor manufacturer's catalog.

Table 4 Coupling models

Motor attachment	Coupling models	Manufacturer	Coupling inertia J_c $\times 10^{-5} \text{kg} \cdot \text{m}^2$
AT401	RA-30C- 8×14	Sakai Manufacturing Co., Ltd	0.281
AT402	RA-35C-12×14	Sakai Manufacturing Co., Ltd	0.847
AT403	RA-35C-14×15	Sakai Manufacturing Co., Ltd	0.847
AT404	RA-40C-15×19	Sakai Manufacturing Co., Ltd	1.365
AT405	RA-30C- 8×11	Sakai Manufacturing Co., Ltd	0.281
AT406	RA-35C-12×14	Sakai Manufacturing Co., Ltd	0.847
AT407	RA-35C-14×15	Sakai Manufacturing Co., Ltd	0.847
AT408	RA-40C-15×19	Sakai Manufacturing Co., Ltd	1.365
AT409	RA-30C- 8×10	Sakai Manufacturing Co., Ltd	0.281
AT411	RA-35C-12×14	Sakai Manufacturing Co., Ltd	0.847
AT412	RA-35C-14×15	Sakai Manufacturing Co., Ltd	0.847

Remark: For detailed coupling specifications, please see respective manufacturer's catalog.

Table 5 Linear encoder code

Linear encoder type	Symbol	Supported AC servomotors	Resolution [μm]	Linear encoder model	
Without linear encoder	S0000	—	—	—	
Incremental linear encoder	SA000	Yaskawa Electric Corporation Σ-7	Variable	HEIDENHAIN K.K. LIF181R	
	SC000	—	Variable	Renishaw plc. TONiC	
	SB010	Mitsubishi Electric Corporation J4 ⁽¹⁾ and Panasonic Corporation MINAS A6	0.01	HEIDENHAIN K.K. LIF181R	
	SB020		0.02		
	SB040		0.04		
	SB050		0.05		
	SB100		0.1		
	SB200		0.2		
	SD010		0.01		Renishaw plc. VIONiC
	SD020		0.02		
	SD040		0.04		
	SD050		0.05		
SD100	0.1				
SD200	0.2				
Absolute linear encoder	SE050	Yaskawa Electric Corporation Σ-7	0.05	Renishaw plc. RESOLUTE	
	SF050	Mitsubishi Electric Corporation J4	0.05		
	SG050	Panasonic Corporation MINAS A6	0.05		

Note⁽¹⁾ Please use an MR-J4-***-RJ driver.

Remarks 1. For details of SA000 and SC000 variable resolution, see Table 7.

2. For linear encoder specification, see Table 11.

Specifications

Table 6 Accuracy

Model and size	Stroke length		Positioning Repeatability	Positioning accuracy	Lost motion ⁽¹⁾	Parallelism in table motion A	Attitude accuracy ⁽²⁾ sec	Straightness in vertical Straightness in horizontal	Squareness of XY motion
	X-axis	Y-axis							
Single-axis specification	TX120M	100	±0.0005 (±0.001)	0.003 (0.006)	0.001	0.005	5	0.003	—
		150							
		200							
		250							
	TX220M	150	±0.0005 (±0.001)	0.003 (0.006)	0.001	0.005	5	0.003	—
		200							
		250							
		300							
	TX320M	300	±0.0005 (±0.001)	0.004 (0.008)	0.001	0.006	6	0.004	—
		400							
		500							
		400							
TX420M	500	±0.0005 (±0.001)	0.005 (0.013)	0.001	0.007	7	0.005	—	
	600								
	800								
	800								
Two-axis specification	CTX120M	100	±0.0005 (±0.001)	0.005 (0.007)	0.001	0.008	8	0.005	0.005
		200							
		200							
		300							
	CTX220M	200	±0.0005 (±0.001)	0.006 (0.010)	0.001	0.009	9	0.006	0.005
		300							
		300							
		400							

Notes ⁽¹⁾ When no linear encoder is used, this represents the value for backlash.

⁽²⁾ This represents accuracy in pitching and yawing.

Remark: The values in () indicate values without a linear encoder.

1N=0.102kgf=0.2248lbs.
1mm=0.03937inch

Specifications

Table 7 Maximum speed attained when a motor manufactured by YASKAWA ELECTRIC CORPORATION is used (with incremental linear encoder)

Designation of linear encoder	Resolution $\mu\text{m/pulse}$	Maximum speed mm/s		Linear encoder	Serial conversion unit (1)
		Lead 5mm	Lead 10mm		
SA000	0.0156	62.5	62.5	HEIDENHAIN K.K. LIF181R	Yaskawa Electric Corporation JZDP-H003-000
	0.0312	125	125		
	0.0625	250 (224)	250 (224)		
	0.125		500 (448)		
	0.250				
	0.500				
SC000	0.0781	250 (224)	312.5	Renishaw plc. TONiC	Yaskawa Electric Corporation JZDP-H005-000
	0.156				
	0.312		500 (448)		
	0.625				
	1.25				
	2.5				

Note (1) Serial conversion unit is attached.

Remarks 1. The values in () are applicable to TX320M and TX420M.

2. Practical maximum speed varies depending on load condition.

3. To change the maximum speed, the resolution needs to be changed by setting the electronic gear for driver.

Table 8 Maximum speed attained when a motor manufactured by Mitsubishi Electric Corporation or Panasonic Corporation is used (with incremental linear encoder)

Designation of linear encoder	Resolution $\mu\text{m/pulse}$	Maximum speed mm/s		Linear encoder	Linear encoder signal conversion unit (1)
		Lead 5mm	Lead 10mm		
SB010	0.01	40 (2)	40 (2)	HEIDENHAIN K.K. LIF181R	HEIDENHAIN K.K. IBV3271 100F (1)
SB020	0.02	80 (2)	80 (2)		HEIDENHAIN K.K. IBV3271 50F (1)
SB040	0.04	160 (2)	160 (2)		HEIDENHAIN K.K. IBV3271 25F (1)
SB050	0.05	200 (2)	200 (2)		HEIDENHAIN K.K. IBV3271 20F (1)
SB100	0.1	250 (224)	400 (2)		HEIDENHAIN K.K. IBV3171 10F (1)
SB200	0.2	250 (224)	500 (448)		HEIDENHAIN K.K. IBV3171 5F (1)
SD010	0.01	40	40	Renishaw plc. VIONiC	-
SD020	0.02	80	80		
SD040	0.04	160	160		
SD050	0.05	200	200		
SD100	0.1	250 (224)	400		
SD200	0.2	250 (224)	500 (448)		

Notes (1) A linear encoder signal conversion unit corresponding to resolution is attached (Made by HEIDENHAIN K.K.).

(2) Because the allowable value of the linear encoder signal conversion unit maximum response frequency is $\pm 5\%$, the maximum speed may decrease by 5%.

Remarks 1. The values in () are applicable to TX320M and TX420M.

2. Practical maximum speed varies depending on load condition.

3. The included linear encoder signal conversion unit has model numbers set by resolution, so the resolution cannot be changed.

Table 9 Maximum speed attained when a motor manufactured by Yaskawa Electric Corporation, Mitsubishi Electric Corporation, or Panasonic Corporation is used (with absolute linear encoder)

Designation of linear encoder	Resolution $\mu\text{m/pulse}$	Maximum speed mm/s		Linear encoder	Linear encoder signal conversion unit
		Lead 5mm	Lead 10mm		
SE050	0.05	250 (224)	500 (448)	Renishaw plc. RESOLUTE	-
SF050	0.05	250 (224)	500 (448)		
SG050	0.05	250 (224)	500 (448)		

Remarks 1. The values in () are applicable to TX320M and TX420M.

2. Practical maximum speed varies depending on load condition.

3. The included linear encoder signal conversion unit has model numbers set by resolution, so the resolution cannot be changed.

Table 10 Maximum speed attained when no linear encoder is used

Motor type	Model and size	Maximum speed mm/s	
		Lead 5mm	Lead 10mm
AC servo motor	TX120M	250	500
	TX220M		
	TX320M	224	448
	TX420M		
Stepper motor	TX120M	150	300
	TX220M		
	TX320M		

Remark: The values of respective axes in tables of two-axis specification are the same as those of tables of single-axis specification.

Table 11 Linear encoder specification

Item	Content			
	LIF181R	TONiC	VIONiC	RESOLUTE
Model	LIF181R	TONiC	VIONiC	RESOLUTE
Manufacturer	HEIDENHAIN K.K.	Renishaw plc		
Material of scale main body	Glass	Low expansion nickel alloy		
Coefficient of linear expansion / $^{\circ}\text{C}$	8×10^{-6}	$0.75 \pm 0.35 \times 10^{-6}$		
Accuracy class $\mu\text{m/m}$	± 1	± 1	± 1	± 1
Output type	Sine wave (1Vpp)	Sine wave (1Vpp)	Square wave	Serial communication
Signal cycle μm	4	20	20	30
Maximum scanning speed m/sec	4	10	12	100
Cord length m	3	3	3	3
Cord diameter mm	$\phi 4.5$	$\phi 4.25 \pm 0.25$	$\phi 4.25 \pm 0.25$	$\phi 4.7 \pm 0.2$
Cord bending radius mm	When movable: 50 or more	When movable: 20 or more	When movable: 30 or more	When movable: 20 or more
	When fixed: 10 or more	When fixed: 10 or more	When fixed: 10 or more	When fixed: 10 or more

Table 12 Serial conversion unit specification for YASKAWA ELECTRIC CORPORATION

Item	Content	
	HEIDENHAIN K.K. LIF181R	Renishaw plc. TONiC
Linear encoder	HEIDENHAIN K.K. LIF181R	Renishaw plc. TONiC
Serial conversion unit model	JZDP-H003-000	JZDP-H005-000
Signal resolution	1/256 of input two phase sine wave pitch	
Maximum responding frequency kHz	250	
Size mm	90 \times 60 \times 23	
Mass kg	0.15	

Remark The connection cable for the serial conversion unit and driver must be prepared by the customer.

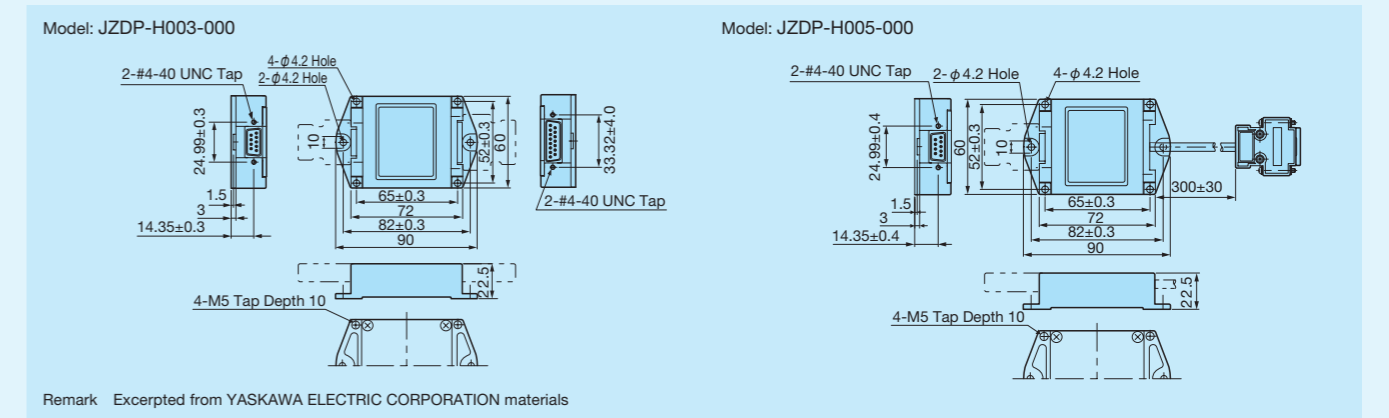

Table 13 Linear encoder signal conversion unit specification for Panasonic Corporation and Mitsubishi Electric Corporation

Item	Content					
	HEIDENHAIN K.K.			HEIDENHAIN K.K.		
Linear encoder model	IBV 3171 [5F, 10F] 0.22 μs			IBV 3271 [20F, 25F, 50F, 100F] 0.22 μs		
Signal resolution	Input two phase sine wave pitch \div 4-time multiplication \div electronic division ratio					
Maximum responding frequency (1) kHz	5F : 200	10F : 200	20F : 100	25F : 80	50F : 40	100F : 20
Size mm	Converter part: 50 \times 41 \times 16					
	Connector part: 48 \times 42 \times 17					
	Cord length: 1000					
Mass kg	0.13					

Remark The connection cable for the signal conversion unit and driver must be prepared by the customer.

Table 14 Maximum carrying mass

Model and size	Ball screw lead mm	Carrying mass center of gravity mm	Maximum carrying mass kg							
			Horizontal direction				Vertical direction			
		Length L	0	100	200	300	0	100	200	300
TX120M	5	0	254	97	57	40	28	28	28	28
		100	254	96	57	40	28	28	28	28
		200	254	95	56	40	28	28	28	28
		300	233	92	56	40	28	28	28	26
	10	0	154	76	44	31	28	28	28	28
		100	154	74	44	31	28	28	28	27
TX220M	5	0	382	263	167	123	30	30	30	30
		100	382	261	167	122	30	30	30	30
		200	382	258	166	122	30	30	30	30
		300	382	254	165	122	30	30	30	30
	10	0	187	187	131	96	29	29	29	29
		100	187	187	130	95	29	29	29	29
TX320M	5	0	536	536	536	473	27	27	27	27
		100	536	536	536	472	27	27	27	27
		200	536	536	536	471	27	27	27	27
		300	536	536	536	469	27	27	27	27
	10	0	254	254	254	254	25	25	25	25
		100	254	254	254	254	25	25	25	25
TX420M	5	0	519	519	519	519	10	10	10	10
		100	519	519	519	519	10	10	10	10
		200	519	519	519	519	10	10	10	10
		300	519	519	519	519	10	10	10	10
	10	0	237	237	237	237	8	8	8	8
		100	237	237	237	237	8	8	8	8
		200	237	237	237	237	8	8	8	8
		300	237	237	237	237	8	8	8	8

Remark 1. The maximum carrying mass is adjusted by the mass when the rating life of the linear motion rolling guide, ball screws, or bearings is 18,000 hours during continuous operation at a number of revolutions of the motor of 3000min⁻¹ and an acceleration/deceleration time of 0.2s. The mass calculated is based upon the basic static load rating of the linear motion rolling guide.
2. Please also check the maximum load mass on page III-19.

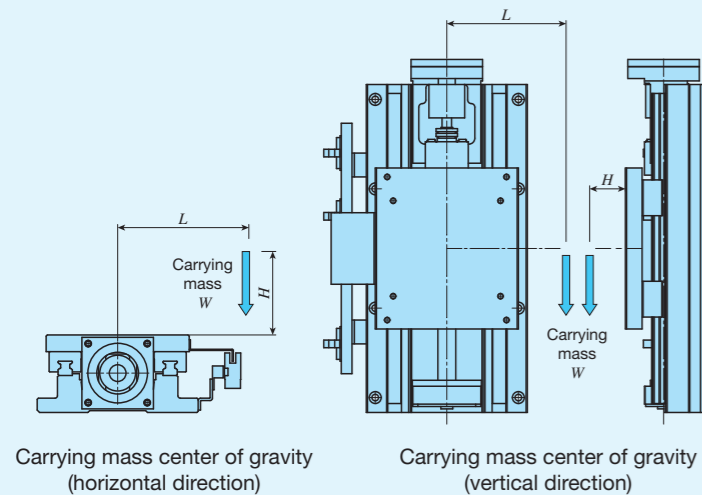

Table 15 Specifications of linear motion rolling guide

Model and size	Basic dynamic load rating ⁽¹⁾ C N	Basic static load rating ⁽¹⁾ C ₀ N	Arrangement			
			L mm	ℓ mm	Y _d mm	Z _d mm
TX120M	6 120	10 400	88	82	0	2
TX220M	11 500	20 000	157	145	0	1
TX320M	32 100	56 300	240	210	0	6
TX420M	38 200	70 300	300	290	0	0

Note ⁽¹⁾ Represent the value per slide unit.
Remark: The values of respective axes in tables of two-axis specification are the same as those of tables of single-axis specification.

Table 16.1 Specifications of ball screw 1

Model and size	Ball screw type	Lead mm	Shaft dia. mm	Axial clearance mm	Basic dynamic load rating C N	Basic static load rating C ₀ N
TX120M	Ground screw	5	15	0	7 070	12 800
		10			7 070	12 800
TX220M	Ground screw	5	20	0	8 230	17 150
		10			10 900	21 700
TX320M	Ground screw	5	25	0	16 700	43 500
		10			15 800	32 700
TX420M	Ground screw	5	25	0	16 700	43 500
		10			15 800	32 700

Remark: The values of respective axes in tables of two-axis specification are the same as those of tables of single-axis specification.

Table 16.2 Specifications of ball screw 2

unit: mm

Model and size	Stroke length	Shaft dia.	Overall length
TX120M	100	15	256
	150		306
	200		356
	250		406
	300		456
TX220M	150	20	370
	200		420
	250		470
	300		520
TX320M	300	25	616
	400		716
	500		816
TX420M	500	25	916
	600		1 016
	800		1 216

Table 17 Table inertia and starting torque

Model and size	Stroke length mm		Table inertia J_T $\times 10^{-9} \text{kg} \cdot \text{m}^2$		Coupling inertia J_c $\times 10^{-5} \text{kg} \cdot \text{m}^2$	Starting torque T_s N·m	
	X-axis	Y-axis	Lead 5mm	Lead 10mm			
Single-axis specification	TX120M	100		1.3	1.8	0.29	0.07
		150		1.5	2.0		
		200		1.6	2.2		
		250		1.8	2.4		
		300		2.0	2.6		
	TX220M	150		5.2	7.0	0.85	0.12
		200		5.8	7.6		
		250		6.4	8.2		
	TX320M	300		7.1	8.8	0.85	0.26
		400		20	26		
500			23	29			
TX420M	500		26	32	0.85	0.30	
	600		30	39			
	800		33	42			
Two-axis specification	CTX120M	100	100	2.1	4.7	0.29	0.07
		200	100	2.4	5.1		
		200	200	2.5	5.8		
		300	200	2.9	6.2		
	CTX220M	200	200	8.2	16.9	0.85	0.13
		300	200	9.5	18.1		
		300	300	9.8	19.3		
		400	300	11.0	20.5		

Remark: As for tables of two-axis specification, the figures represent values in X-axis. For values in Y-axis, see the table for single-axis specification.

Mounting

For the processing accuracy of the Precision Positioning Table mounting surface and the tightening torque of the fixing screws, see page III-36.

Sensor Specification

Table 18 Sensor timing chart

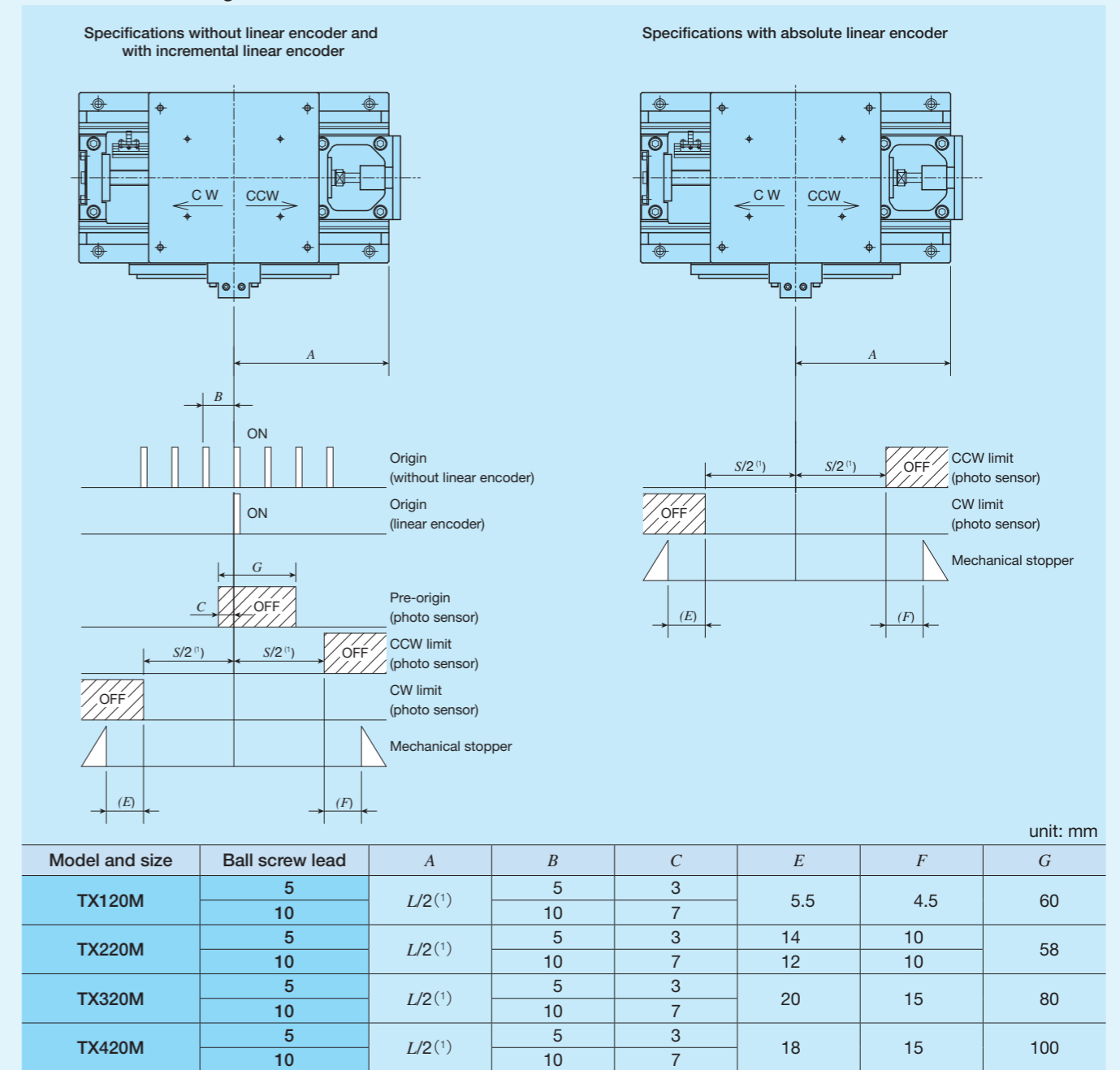

Note ⁽¹⁾ See the dimension tables on page II-164 to II-169.

- Remarks
- For detailed specifications of respective sensors, please see the section of sensor specification in General Explanation.
 - The values of respective axes in tables of two-axis specification are the same as those of tables of single-axis specification.
 - The linear encoder count increases in the CCW direction.

Dimensions of Motor Attachment

TX120M, CTX120M

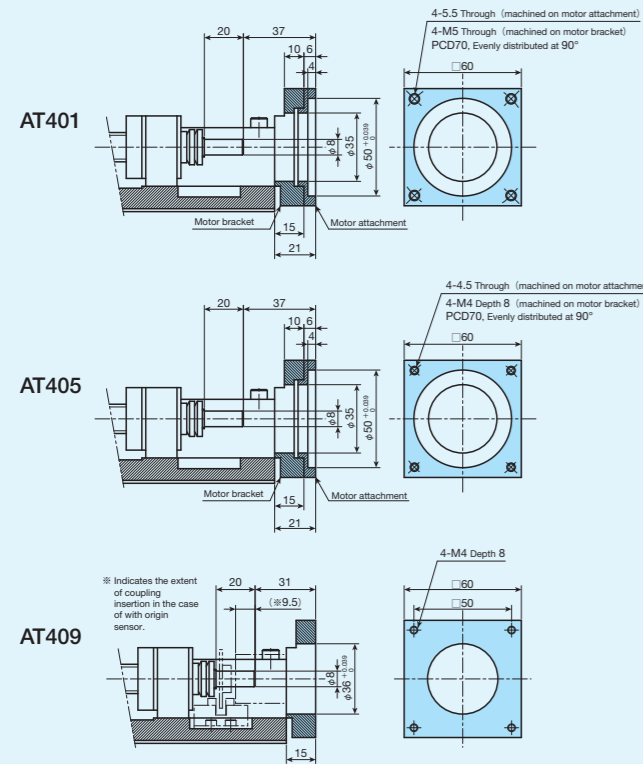

TX220M, CTX220M

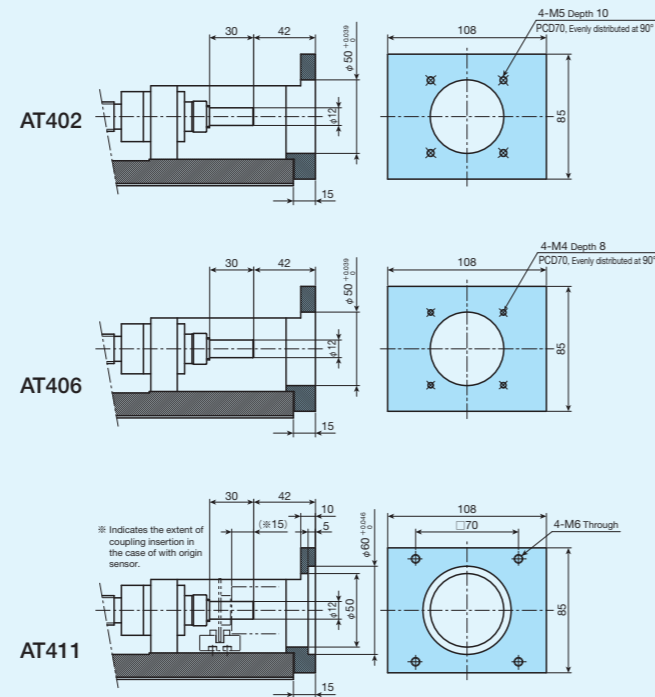

TX320M

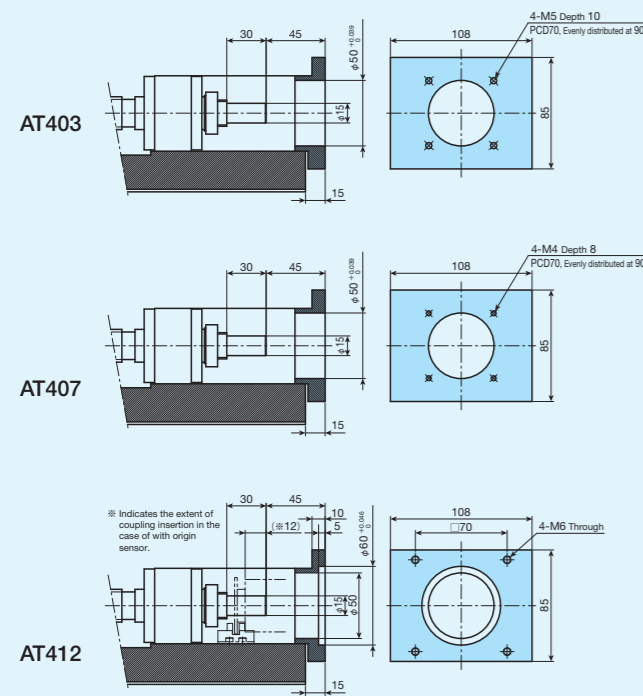

TX420M

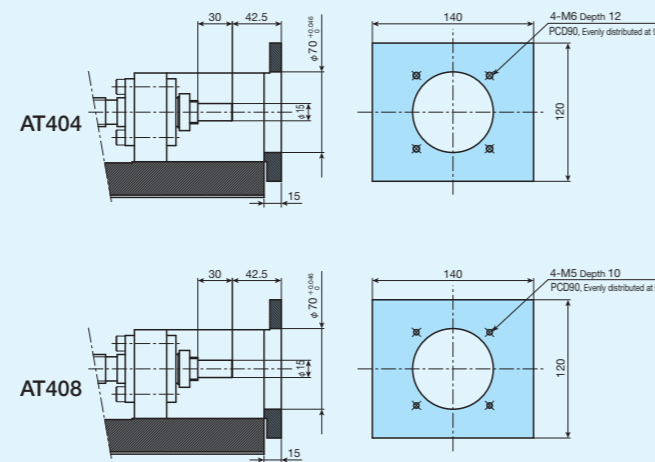

IKO Super Precision Positioning Table TX

TX120M

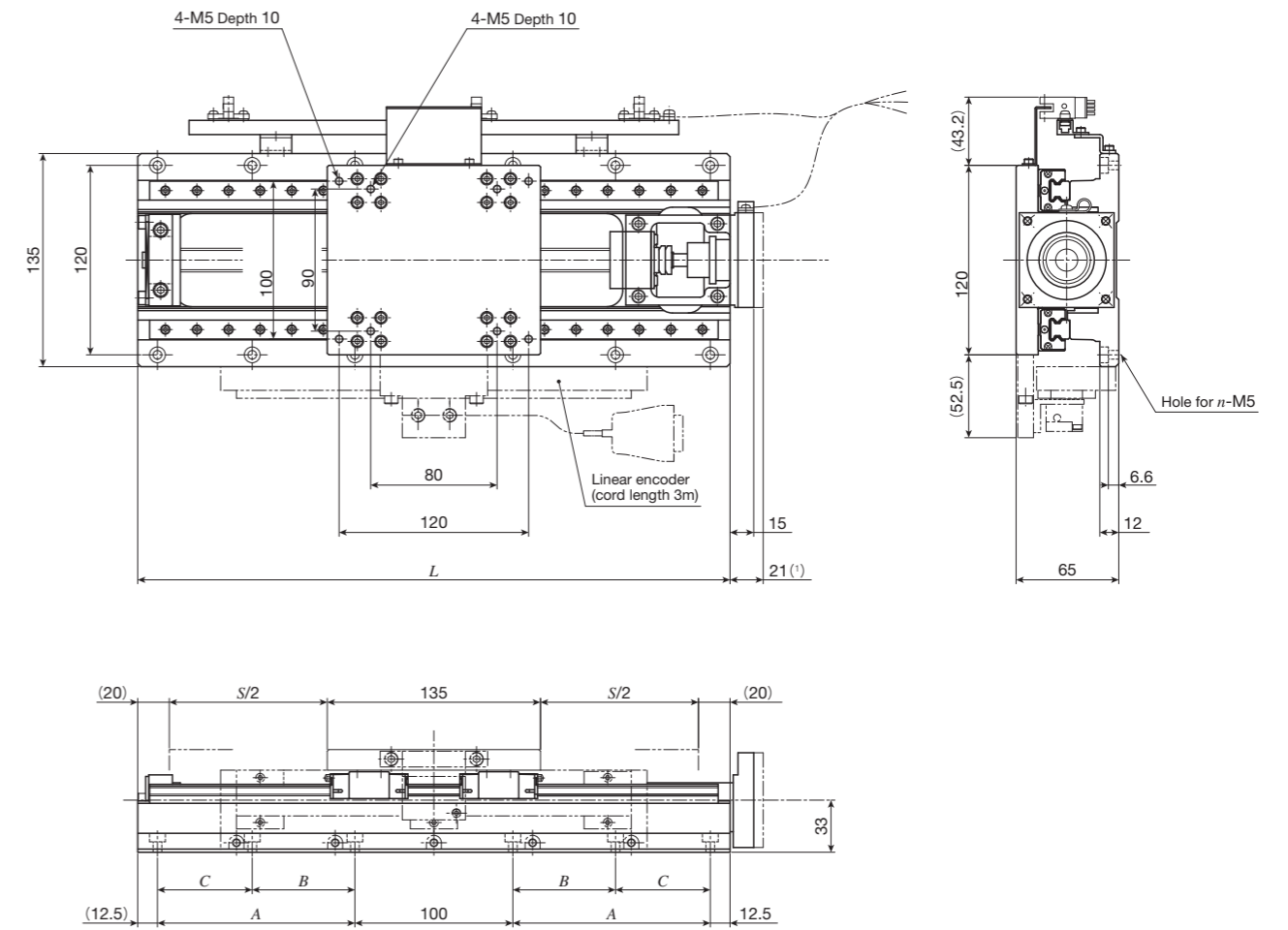

unit: mm

Identification number	Stroke length <i>S</i>	Overall length <i>L</i>	Mounting holes of bed				Mass (Ref.) kg
			<i>A</i>	<i>B</i>	<i>C</i>	<i>n</i>	
TX120M-100	100	275	75	—	—	8	12
TX120M-150	150	325	100	—	—	8	13
TX120M-200	200	375	125	—	—	8	14
TX120M-250	250	425	150	75	75	12	16
TX120M-300	300	475	175	100	75	12	17

Note (1) This applies to AT401 and AT405.

IKO Super Precision Positioning Table TX

TX220M

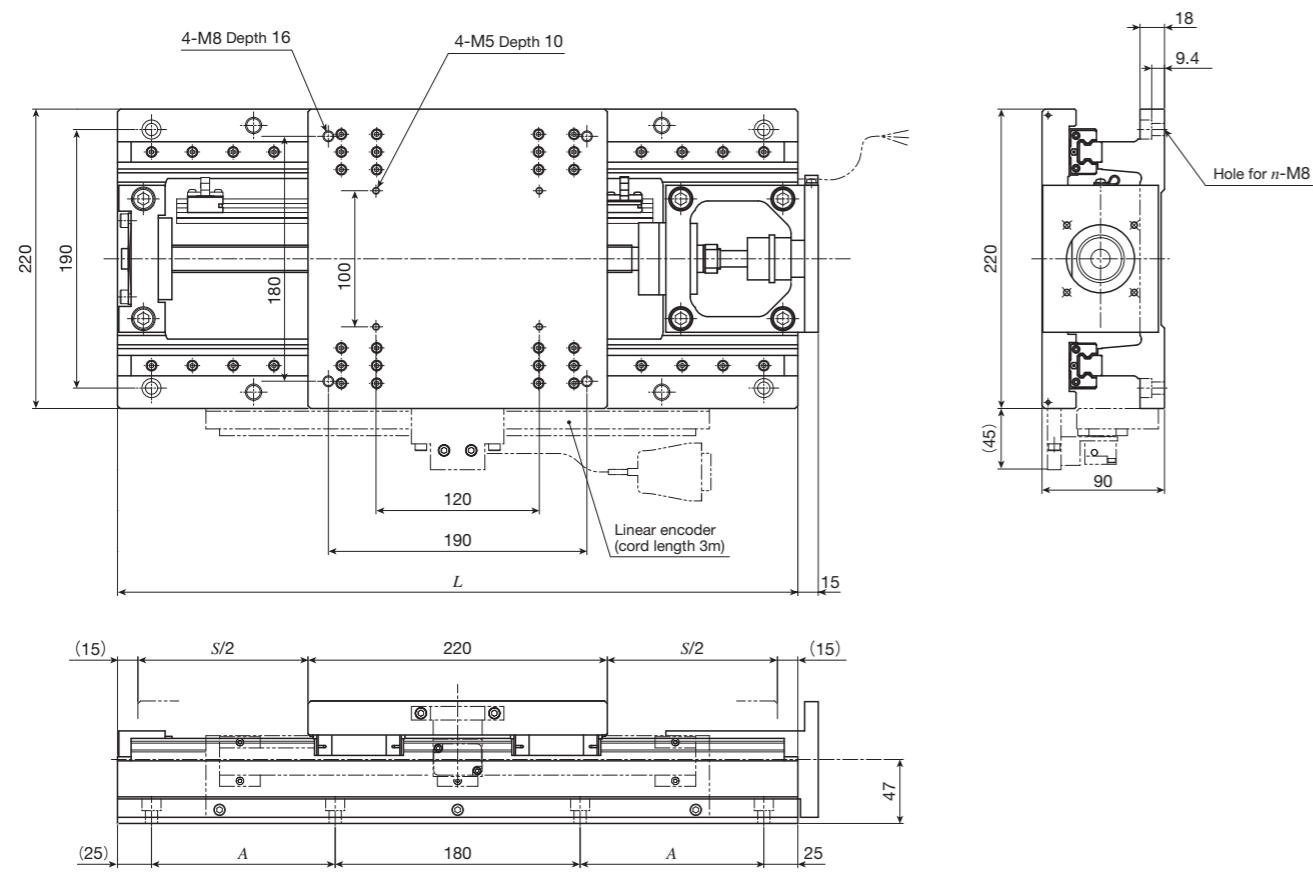

unit: mm

Identification number	Stroke length <i>S</i>	Overall length <i>L</i>	Mounting holes of bed		Mass (Ref.) kg
			<i>A</i> (the number of holes × pitch)	<i>n</i>	
TX220M-150	150	400	85	8	34
TX220M-200	200	450	110	8	37
TX220M-250	250	500	135	8	39
TX220M-300	300	550	160	8	42
TX220M-400	400	650	210 (2 × 105)	12	47

TX320M

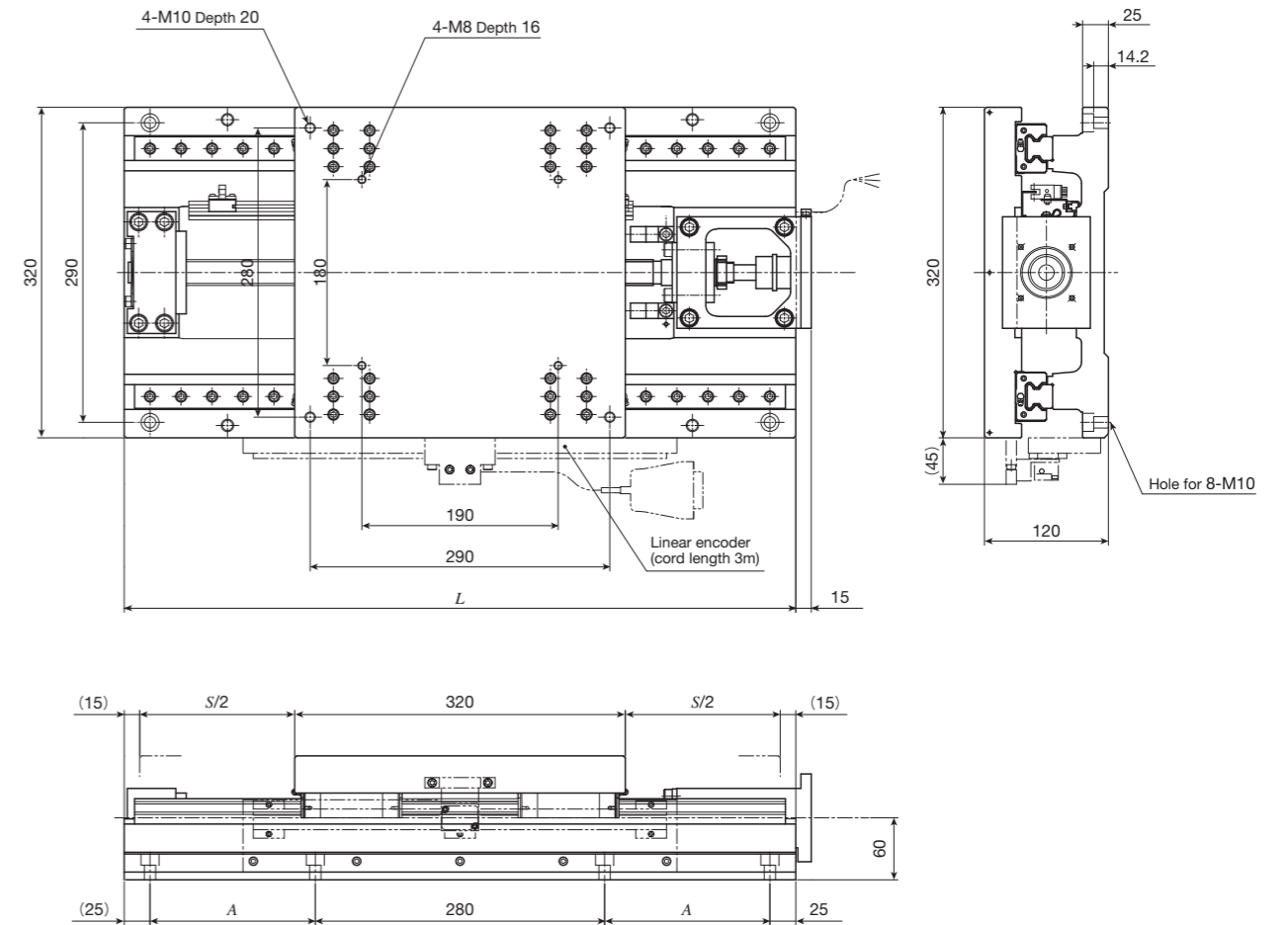

unit: mm

Identification number	Stroke length <i>S</i>	Overall length <i>L</i>	Mounting holes of bed <i>A</i>	Mass (Ref.) kg
TX320M-400	400	750	210	115
TX320M-500	500	850	260	124

IKO Super Precision Positioning Table TX

TX420M

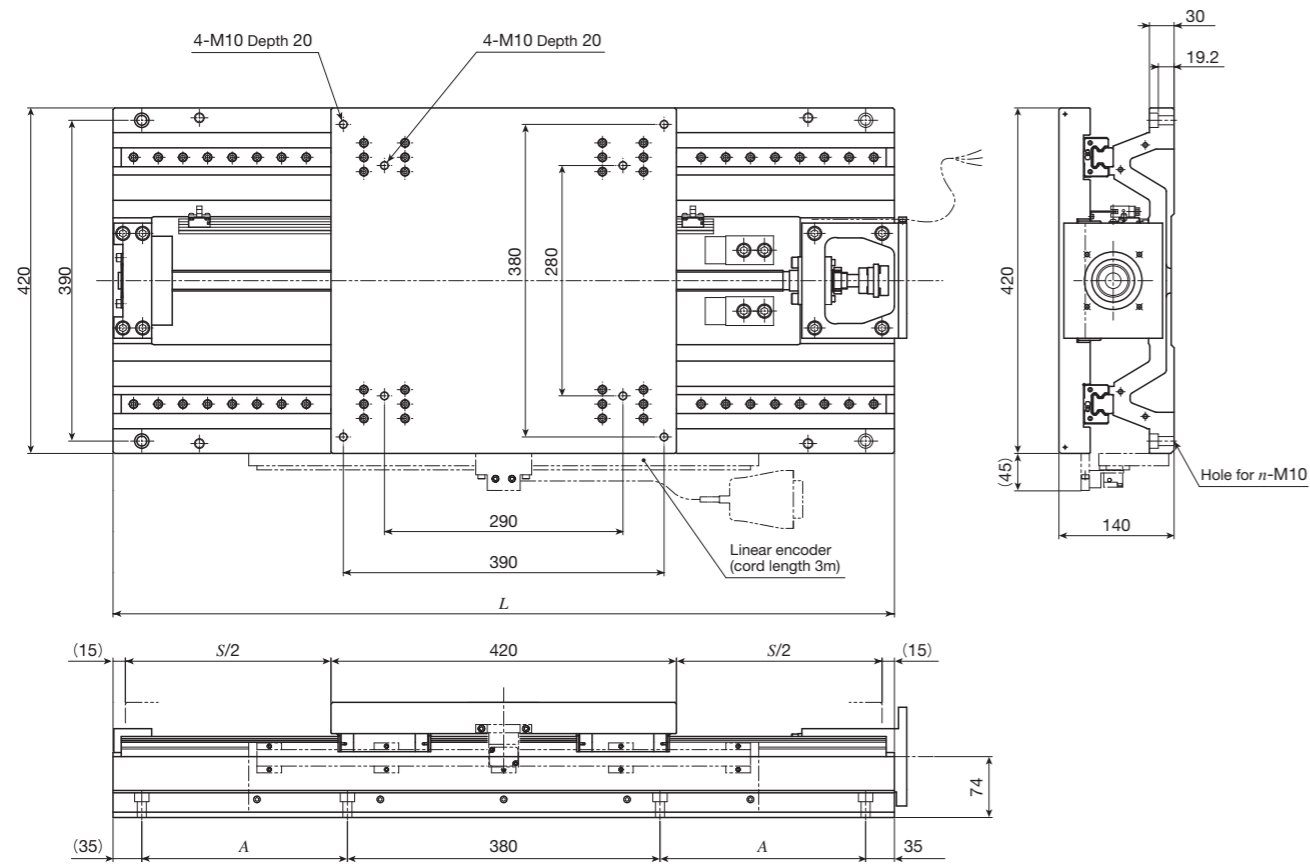

unit: mm

Identification number	Stroke length <i>S</i>	Overall length <i>L</i>	Mounting holes of bed		Mass (Ref.) kg
			<i>A</i> (the number of holes × pitch)	<i>n</i>	
TX420M-500	500	950	250	8	183
TX420M-600	600	1 050	300	8	197
TX420M-800	800	1 250	400 (2 × 200)	12	223

CTX120M

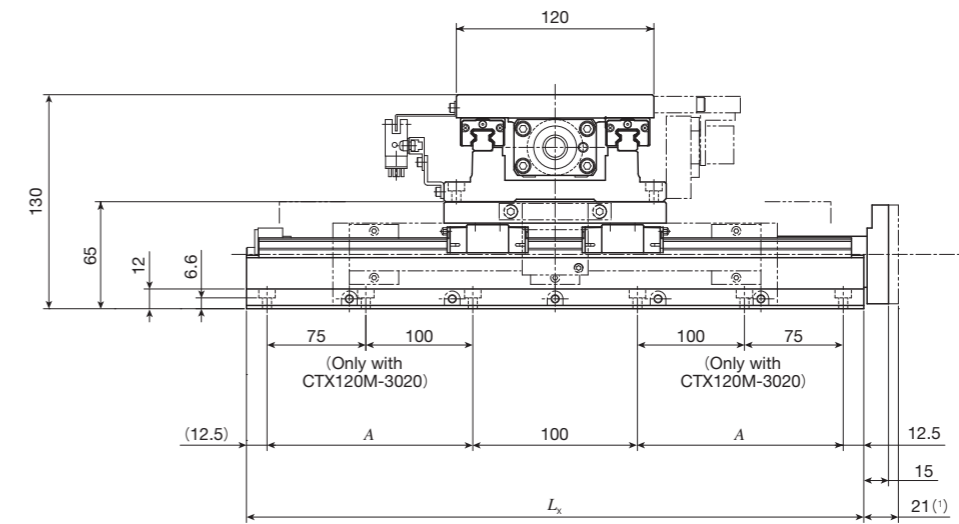
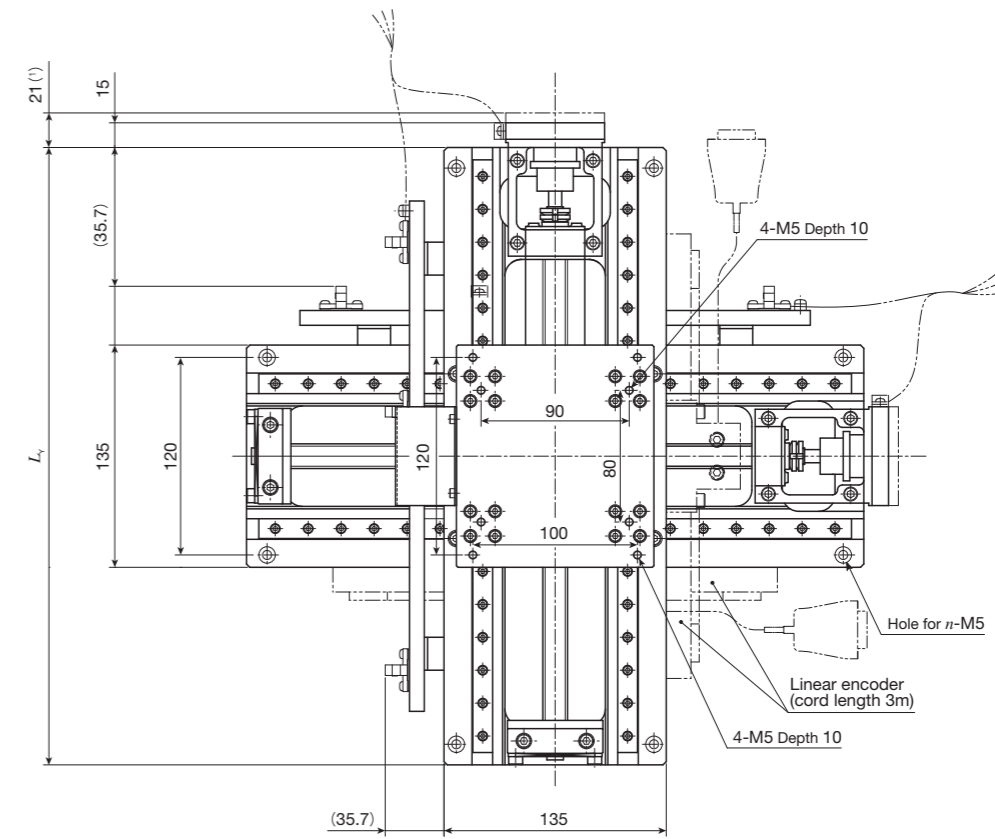

unit: mm

Identification number	Stroke length <i>S</i>		Overall length		Mounting holes of bed		Mass (Ref.) kg
	X-axis	Y-axis	<i>L_x</i>	<i>L_y</i>	<i>A</i>	<i>n</i>	
CTX120M-1010	100	100	275	275	75	8	23
CTX120M-2010	200	100	375	275	125	8	26
CTX120M-2020	200	200	375	375	125	8	28
CTX120M-3020	300	200	475	375	175	12	31

Note (1) This applies to AT401 and AT405.

Remarks 1. The combination for CTX in the above figure is the standard configuration.

2. Since other combinations of stroke lengths other than those listed above, different table sizes, as well as production of cableveyor specification are possible, please contact IKO.

IKO Super Precision Positioning Table TX

CTX220M

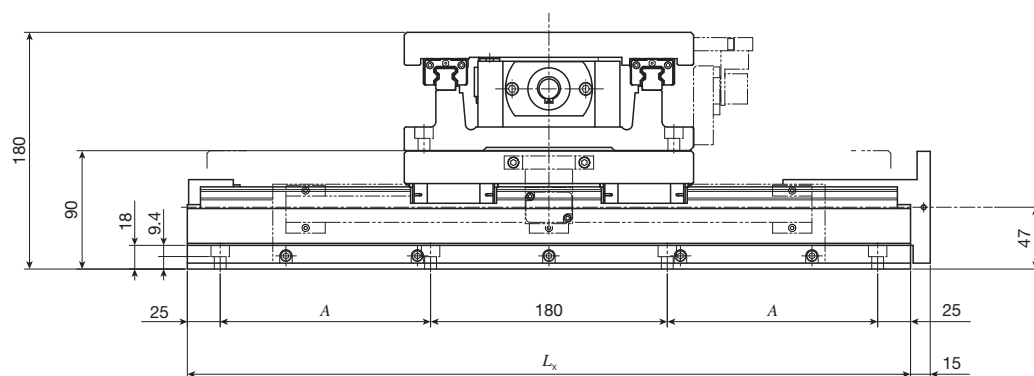
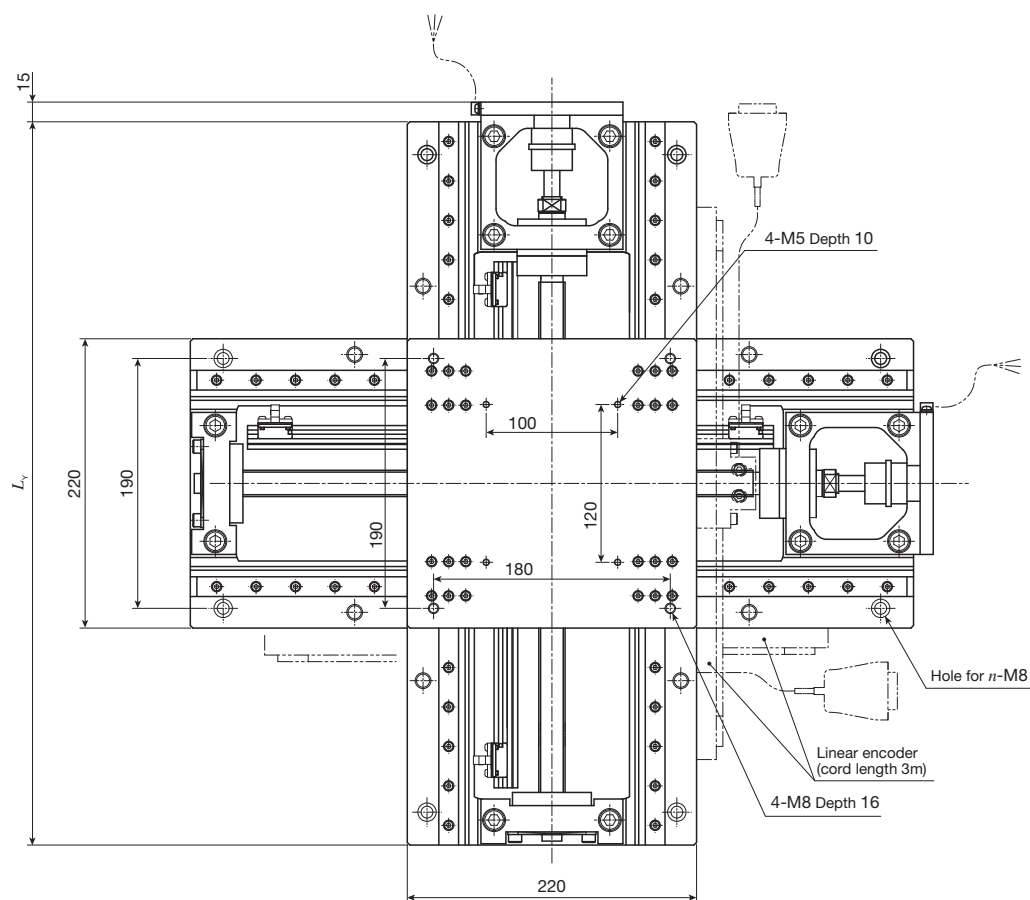

unit: mm

Identification number	Stroke length S		Overall length		Mounting holes of bed		Mass (Ref.) kg
	X-axis	Y-axis	L_x	L_y	A (the number of holes \times pitch)	n	
CTX220M-2020	200	200	450	450	110	8	73
CTX220M-3020	300	200	550	450	160	8	78
CTX220M-3030	300	300	550	550	160	8	83
CTX220M-4030	400	300	650	550	210 (2 \times 105)	12	88

Remarks 1. The combination for CTX in the above figure is the standard configuration.

2. Since other combinations of stroke lengths other than those listed above, different table sizes, as well as production of cableveyor specification are possible, please contact IKO.